



Chipsmall Limited consists of a professional team with an average of over 10 year of expertise in the distribution of electronic components. Based in Hongkong, we have already established firm and mutual-benefit business relationships with customers from,Europe,America and south Asia,supplying obsolete and hard-to-find components to meet their specific needs.

With the principle of “Quality Parts,Customers Priority,Honest Operation,and Considerate Service”,our business mainly focus on the distribution of electronic components. Line cards we deal with include Microchip,ALPS,ROHM,Xilinx,Pulse,ON,Everlight and Freescale. Main products comprise IC,Modules,Potentiometer,IC Socket,Relay,Connector.Our parts cover such applications as commercial,industrial, and automotives areas.

We are looking forward to setting up business relationship with you and hope to provide you with the best service and solution. Let us make a better world for our industry!



Contact us

Tel: +86-755-8981 8866 Fax: +86-755-8427 6832

Email & Skype: info@chipsmall.com Web: www.chipsmall.com

Address: A1208, Overseas Decoration Building, #122 Zhenhua RD., Futian, Shenzhen, China



MAXIM

μP Power-Supply Monitor with Reset

MAX7705

General Description

In applications with microprocessors (μPs) that have a RESET input, the MAX7705 is functionally and socket compatible with the TL7705, but requires **no external components**. It provides power-supply glitch immunity and a guaranteed power-up reset delay, while typically consuming 1/27th the power from a +5V supply.

The MAX7705 monitors the power supply in μP and digital systems. The RESET output is valid for V_{CC} down to 1V. The device offers excellent circuit reliability and low cost by eliminating external components and adjustments.

A system reset is provided during power-up, power-down, and brownout conditions. When V_{CC} is below the reset threshold, RESET is low and holds the μP in reset. RESET will go high 280ms after V_{CC} rises above the reset threshold. The MAX7705 is available in 8-pin DIP and SO packages.

FEATURE	MAX7705	TL7705	
No. of External Components Required	0	3	
Operating Supply Current	+5V	65μA	1.8mA
	+3V	35μA	1.8mA
Power-Supply Glitch Immunity	Yes	No	
Guaranteed Minimum Reset Delay	Yes	No	

Applications

Minimum Component Count, Low-Cost Processor Systems

Pin Configuration

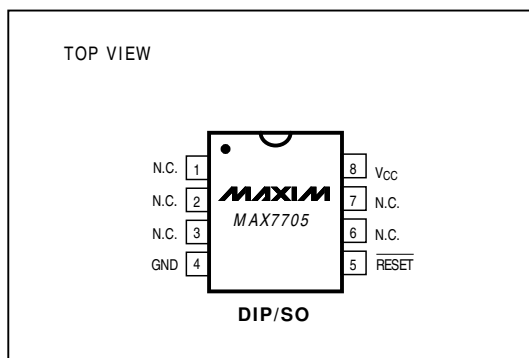

Features

- ♦ No External Components
- ♦ Low Cost
- ♦ Precise Reset Threshold
- ♦ 280ms Power-On Reset Delay
- ♦ 8-Pin DIP and SO Packages

Ordering Information

PART	TEMP. RANGE	PIN-PACKAGE
MAX7705CPA	0°C to +70°C	8 Plastic DIP
MAX7705CSA	0°C to +70°C	8 SO
MAX7705C/D	0°C to +70°C	Dice*
MAX7705EPA	-40°C to +85°C	8 Plastic DIP
MAX7705ESA	-40°C to +85°C	8 SO

* Contact factory for dice specifications.

Typical Operating Circuit

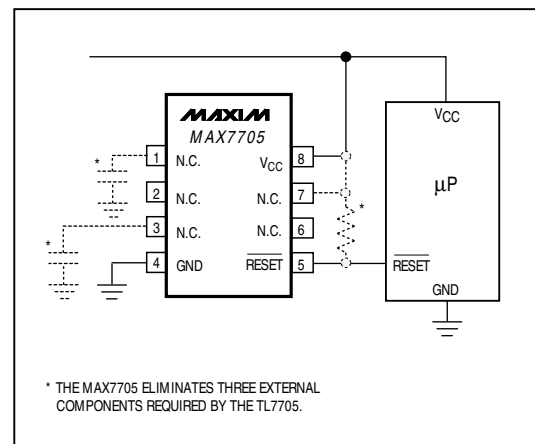

μP Power-Supply Monitor with Reset

ABSOLUTE MAXIMUM RATINGS

Terminal Voltage (with respect to GND)

V_{CC}-0.3V to 6.0V

RESET-0.3V to (V_{CC} + 0.3V)

Input Current, V_{CC}20mA

Output Current, RESET20mA

Rate-of-Rise, V_{CC}100V/μs

Continuous Power Dissipation (T_A = +70°C)

Plastic DIP (derate 9.09mW/°C above +70°C)727mW

SO (derate 5.88mW/°C above +70°C)471mW

Operating Temperature Ranges:

MAX7705C0°C to +70°C

MAX7705E-40°C to +85°C

Storage Temperature Range-65°C to +160°C

Lead Temperature (soldering, 10sec)+300°C

Stresses beyond those listed under "Absolute Maximum Ratings" may cause permanent damage to the device. These are stress ratings only, and functional operation of the device at these or any other conditions beyond those indicated in the operational sections of the specifications is not implied. Exposure to absolute maximum rating conditions for extended periods may affect device reliability.

ELECTRICAL CHARACTERISTICS

(V_{CC} = full range, T_A = T_{MIN} to T_{MAX}, unless otherwise noted.)

PARAMETER	CONDITIONS	MIN	TYP	MAX	UNITS
V _{CC} Range	MAX7705C	1.0		5.5	V
	MAX7705E	1.2		5.5	
Supply Current	MAX7705C, V _{CC} < 5.5V		65	150	μA
	MAX7705E, V _{CC} < 5.5V		65	200	
RESET Threshold		4.50	4.65	4.75	V
V _{CC} to RESET Delay	V _{CC} = reset threshold max to reset threshold min		20		μs
Reset Active Timeout Period	V _{CC} = reset threshold max, V _{CC} rising	140	280	560	ms
RESET Output Voltage	I _{SINK} = 3.2mA, V _{CC} = reset threshold min			0.4	V
	I _{SINK} = 50μA, V _{CC} ≥ 1.0V, MAX7705C			0.3	
	I _{SINK} = 100μA, V _{CC} ≥ 1.2V, MAX7705E			0.4	
	I _{SOURCE} = 800μA, V _{CC} ≥ reset threshold max	V _{CC} - 1.5			

μP Power-Supply Monitor with Reset

Typical Operating Characteristics

(T_A = +25°C, unless otherwise noted.)

MAX7705

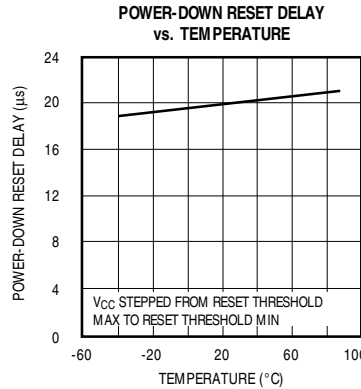
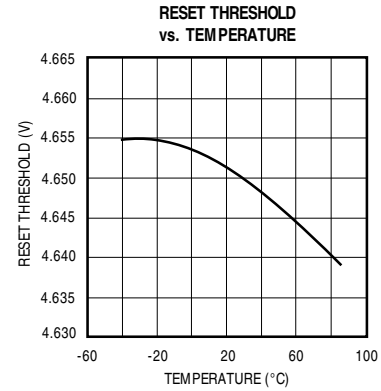
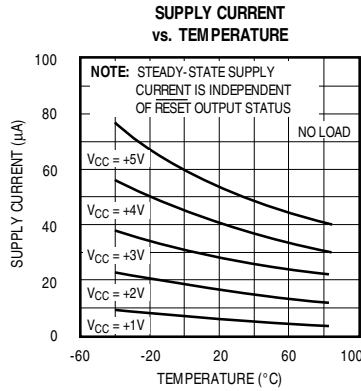
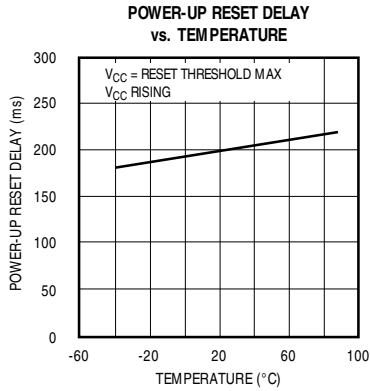

Pin Description

PIN	NAME	FUNCTION
1,2,3,6,7	N.C.	No Connection. There is no internal connection to these pins.
4	GND	Ground
5	RESET	Reset Output remains low while V _{CC} is below the reset threshold, and for 280ms after V _{CC} rises above the reset threshold.
8	V _{CC}	+5V Supply Voltage

μP Power-Supply Monitor with Reset

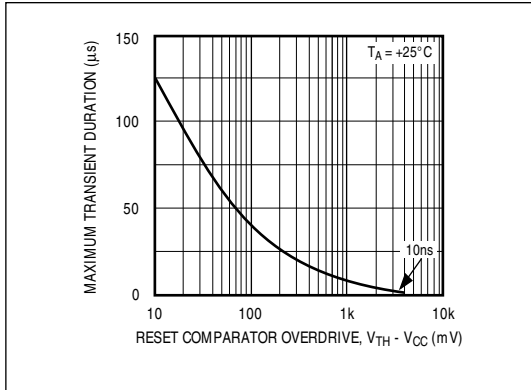

Figure 1. Maximum Transient Duration without Causing a Reset Pulse vs. Reset Comparator Overdrive

Applications Information

Replacing the TL7705 with a MAX7705 in an Existing Design

The MAX7705 has only three active pins: V_{CC} , GND, and RESET. When using a TL7705 with a μP that has a RESET input, simply plug the MAX7705 into the same socket and omit the RESET pull-up resistor, reset timing capacitor, and reference bypass capacitor (see the *Typical Operating Circuit*).

The MAX7705 monitors the V_{CC} voltage and asserts reset whenever V_{CC} falls below the reset threshold. The reset power-up delay is created by an internal fixed oscillator. This delay is 100% tested and guaranteed over the full temperature range. The RESET output both sources and sinks current (see RESET Output Voltage in the *Electrical Characteristics*).

Negative-Going V_{CC} Transients

The MAX7705 asserts RESET during power-up, power-down, and brownout conditions. However, it is relatively immune to short-duration negative-going V_{CC} transients (glitches).

Figure 1 shows typical transient duration vs. reset comparator overdrive for which the MAX7705 does **not** generate a reset pulse. The graph was generated using a fast-edge, negative-going pulse applied to V_{CC} , starting 1.5V above the actual reset threshold and ending below the reset threshold by the magnitude indicated (reset comparator overdrive). It indicates the typical maxi-

imum pulse width a negative-going V_{CC} transient may have without causing a reset pulse to be issued. As the magnitude of the transient increases (goes farther below the reset threshold), the maximum allowable pulse width decreases. Typically, a V_{CC} transient that goes 100mV below the reset threshold and lasts 40μs or less will not cause a reset pulse to be issued.

A 0.1μF bypass capacitor mounted as close as possible to pin 2 (V_{CC}) provides additional transient immunity.

Ensuring a Valid RESET Output Down to $V_{CC} = 0V$

When V_{CC} falls below 1V, the MAX7705 RESET output no longer sinks current; it becomes high impedance. Therefore, high-impedance CMOS logic inputs connected to the RESET output can drift to indeterminate voltages. In most applications this presents no problem, as μP and other circuitry is generally inoperative with V_{CC} below 1V. In applications where the RESET output must be valid down to 0V, adding a pull-down resistor to the RESET pin (as shown in Figure 2) will cause any stray leakage currents to flow to ground, holding RESET low. The resistance value of R1 is not critical. It should be about 100kΩ, which is large enough not to load RESET and small enough to pull RESET to ground.

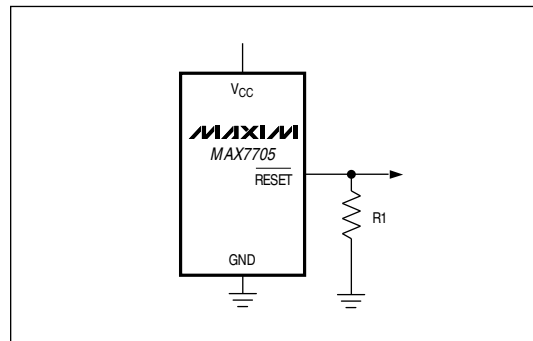

Figure 2. RESET Valid to $V_{CC} = \text{Ground}$ Circuit

μ P Power-Supply Monitor with Reset

Interfacing to μ Ps with Bidirectional Reset Inputs

μ Ps with bidirectional reset pins, such as Motorola's 68HC11 series, can contend with the MAX7705 reset output. If, for example, the MAX7705 RESET output is asserted high and the μ P wants to pull it low, an indeterminate logic level may result. To correct this, connect a 4.7k Ω resistor between the MAX7705 RESET output and the μ P reset I/O, as in Figure 3. Buffer the RESET signal to other system components.

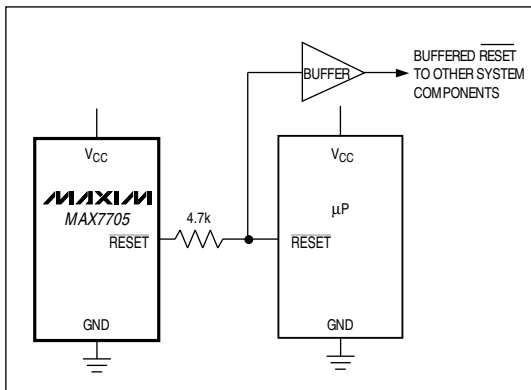
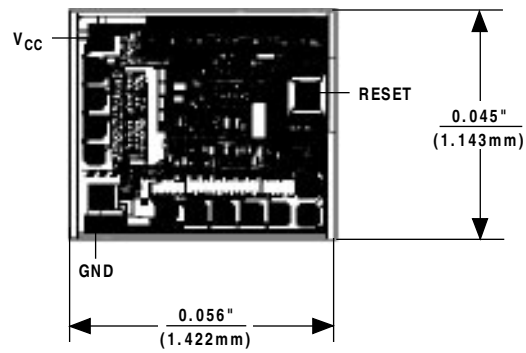

Figure 3. Interfacing to μ Ps with Bidirectional Reset I/O

Chip Topography



MAX7705

TRANSISTOR COUNT = 380;
SUBSTRATE CONNECTED TO V_{CC}.

μP Power-Supply Monitor with Reset

MAX7705

Package Information

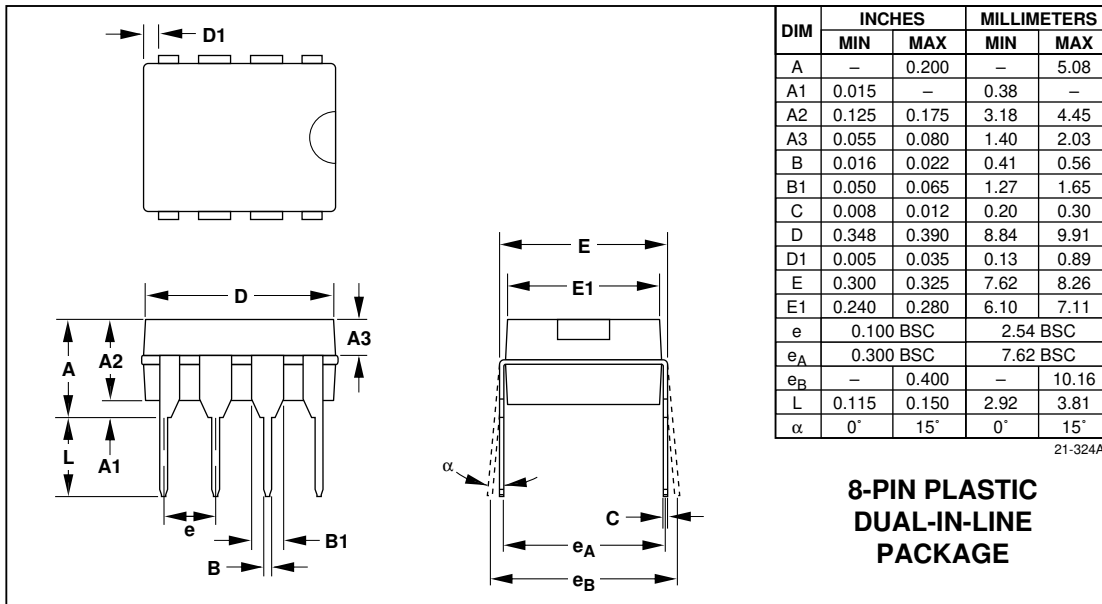

μP Power-Supply Monitor with Reset

Package Information (continued)

MAX7705

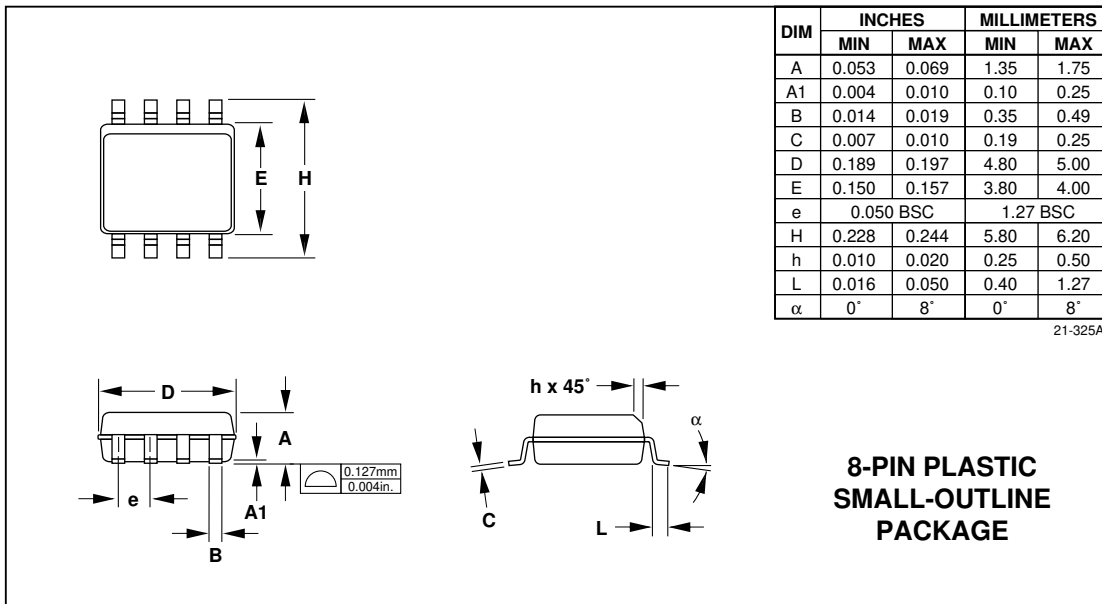

μP Power-Supply Monitor with Reset

MAX7705

μP Supervisory Circuits

Part Number	Nominal Reset Threshold (V)	Minimum Reset Pulse Width (ms)	Nominal Watchdog Timeout Period (sec)	Backup-Battery Switch	CE - Write Protect	Power-Fail Com-parator	Manual-Reset Input	Watch-dog Output	Low-Line Output	Active-High Reset	Battery-On Output
MAX690A/692A	4.65/4.40	140	1.6	✓		✓					
MAX691A/693A	4.65/4.40	140/adj.	1.6/adj.	✓	✓/10ns	✓		✓	✓	✓	✓
MAX696	Adj.	35/adj.	1.6/adj.	✓		✓		✓	✓	✓	✓
MAX697	Adj.	35/adj.	1.6/adj.		✓	✓		✓	✓	✓	
MAX700	4.65/adj.	200	-				✓			✓	
MAX703/704	4.65/4.40	140	-	✓		✓	✓				
MAX705/706	4.65/4.40	140	1.6			✓	✓	✓			
MAX706P	2.63	140	1.6			✓	✓	✓		✓	
MAX706R/S/T	2.63/2.93/ 3.08	140	1.6			✓	✓	✓			
MAX707/708	4.65/4.40	140	-			✓	✓			✓	
MAX708R/S/T	2.63/2.93/ 3.08	140	-			✓	✓			✓	
MAX709L/M/ R/S/T	4.65/4.40/ 2.63/2.93/3.08	140	-								
MAX791	4.65	140	1	✓	✓/10ns	✓	✓	✓	✓	✓	✓
MAX792L/M/ R/S/T	4.65/4.40/ 2.63/2.93/3.08	140	1		✓/10ns	✓	✓	✓	✓	✓	
MAX800L/M	4.60/4.40	140	1.6/adj.	✓	✓/10ns	✓/±2%		✓	✓	✓	✓
MAX802L/M	4.60/4.40	140	1.6	✓		✓/±2%					
MAX805L	4.65	140	1.6	✓		✓				✓	
MAX813L	4.65	140	1.6			✓	✓	✓		✓	
MAX820L/M/ R/S/T	4.65/4.40/ 2.63/2.93/3.08	140	1		✓/10ns	✓/±2%	✓	✓	✓	✓	✓
MAX1232	4.37/4.62	250	0.15/0.60/1.2				✓				
MAX1259	-	-	-	✓		✓					

Maxim cannot assume responsibility for use of any circuitry other than circuitry entirely embodied in a Maxim product. No circuit patent licenses are implied. Maxim reserves the right to change the circuitry and specifications without notice at any time.

8 _____ Maxim Integrated Products, 120 San Gabriel Drive, Sunnyvale, CA 94086 (408) 737-7600

© 1993 Maxim Integrated Products

Printed USA

MAXIM is a registered trademark of Maxim Integrated Products.