



Chipsmall Limited consists of a professional team with an average of over 10 year of expertise in the distribution of electronic components. Based in Hongkong, we have already established firm and mutual-benefit business relationships with customers from,Europe,America and south Asia,supplying obsolete and hard-to-find components to meet their specific needs.

With the principle of “Quality Parts,Customers Priority,Honest Operation,and Considerate Service”,our business mainly focus on the distribution of electronic components. Line cards we deal with include Microchip,ALPS,ROHM,Xilinx,Pulse,ON,Everlight and Freescale. Main products comprise IC,Modules,Potentiometer,IC Socket,Relay,Connector.Our parts cover such applications as commercial,industrial, and automotives areas.

We are looking forward to setting up business relationship with you and hope to provide you with the best service and solution. Let us make a better world for our industry!



Contact us

Tel: +86-755-8981 8866 Fax: +86-755-8427 6832

Email & Skype: info@chipsmall.com Web: www.chipsmall.com

Address: A1208, Overseas Decoration Building, #122 Zhenhua RD., Futian, Shenzhen, China



General Description

The MAX77650/MAX77651 evaluation kit (EV kit) is a fully assembled and tested printed circuit board (PCB) that demonstrates the MAX77650/MAX77651. The EV kit allows for easy evaluation of the various MAX77650/MAX77651 features, including the SIMO buck-boost regulator, linear regulator, analog multiplexer, smart battery charger, on/off controller, and I²C interface.

The MAX77650 and MAX77651 EV kits are identical aside from the device (U1), silkscreen, and two resistive dividers at the SIMO outputs (see the [MAX77650/MAX77651 EV Kit Differences](#) section). The MAX77650/MAX77651 devices themselves have different output voltage ranges for the SIMO buck-boost regulator. Consult the device data sheet for more information.

Windows®-based software provides a user-friendly graphical interface as well as a detailed register-based interface to exercise the features of the MAX77650/MAX77651.

[Ordering Information](#) appears at end of data sheet.

Features

- Easy to Use
- GUI Drives I²C Interface
- On-Board Battery Ammeter
- On-Board Thermistor
- On-Key Options
- RGB LED Cluster
- Assembled and Fully Tested
- Emulates System Loading
- On-Board Electronic Loads
- Electronic Loads have steady-state, transient, and random modes
- Demonstrates End-to-End Analog Multiplexer Implementation
- On-Board ADC
- Evaluates Both Push-Button and Slider-Switch On-Key Options

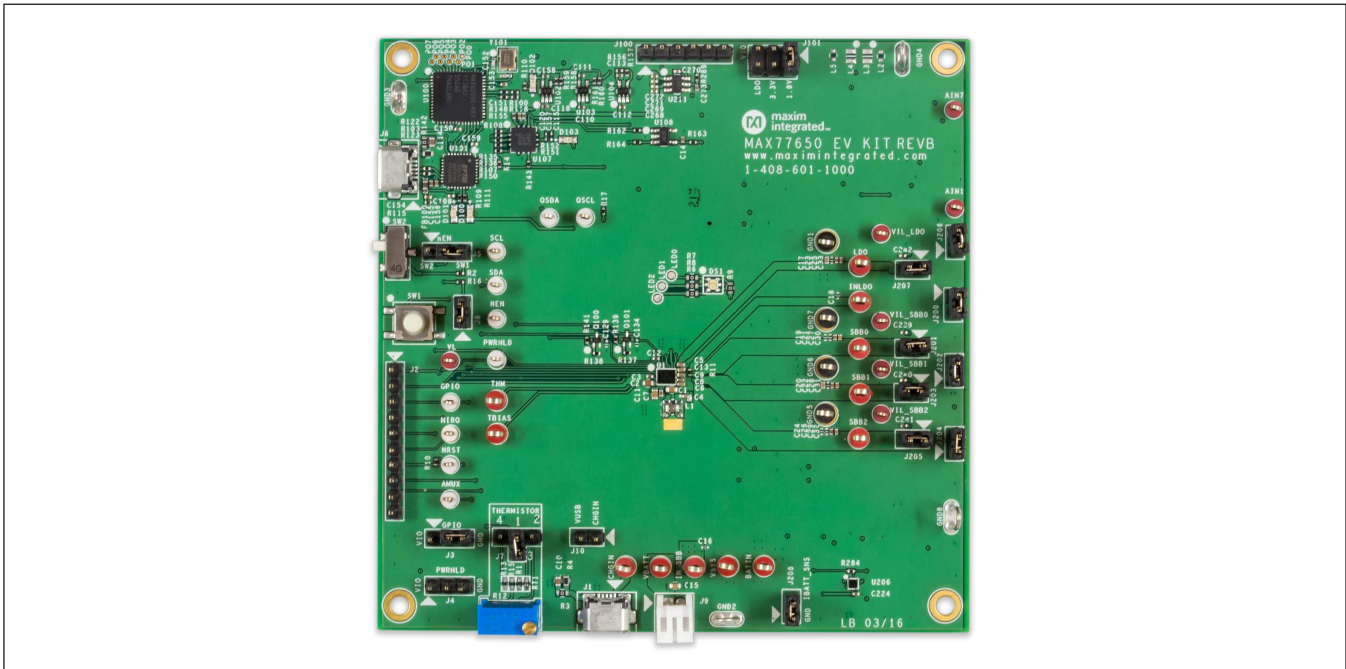

Figure 1. MAX77650 EV Kit Photo

Windows is a registered trademark and registered service mark of Microsoft Corp.



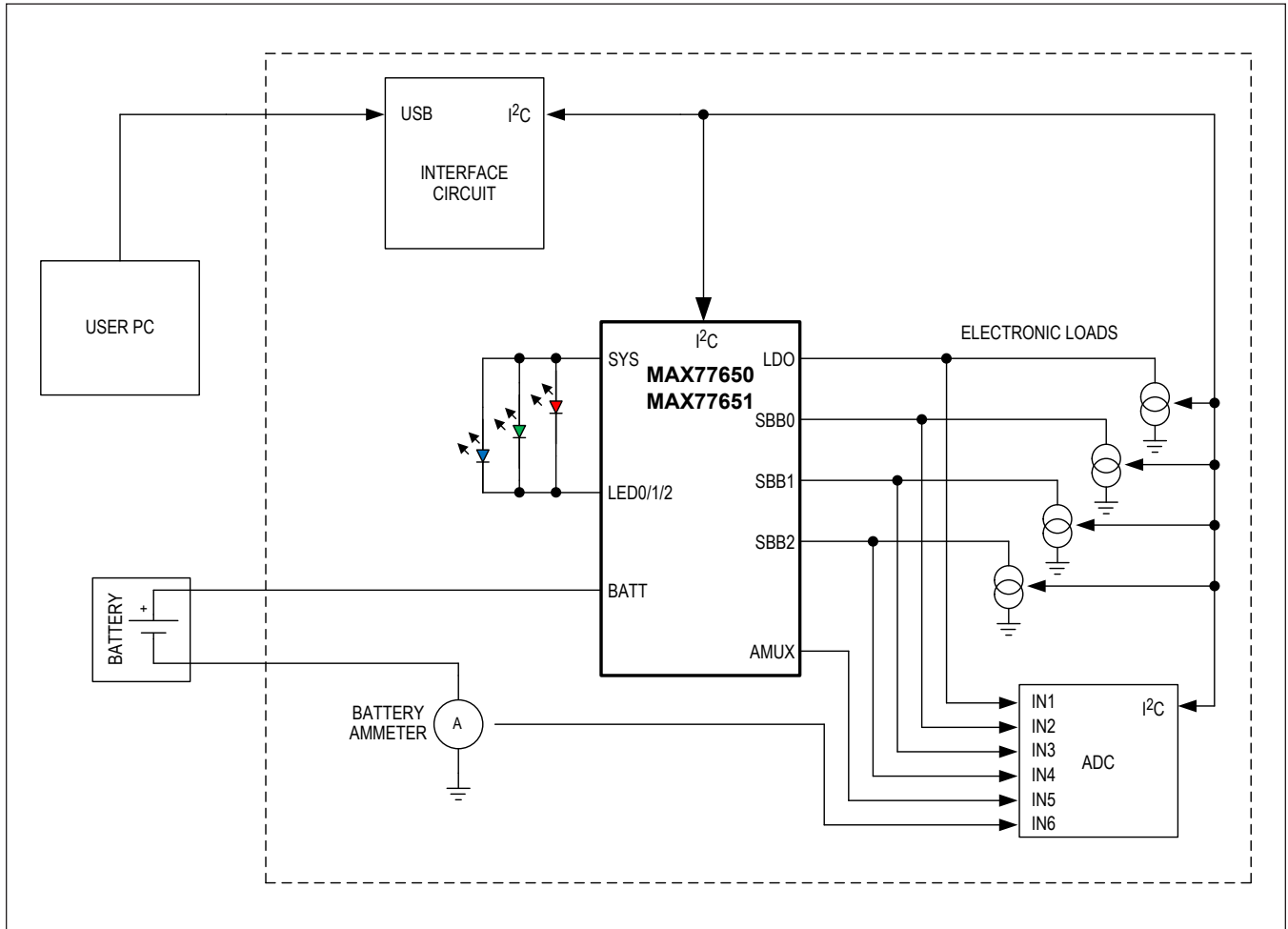

Figure 2. Simplified Block Diagram

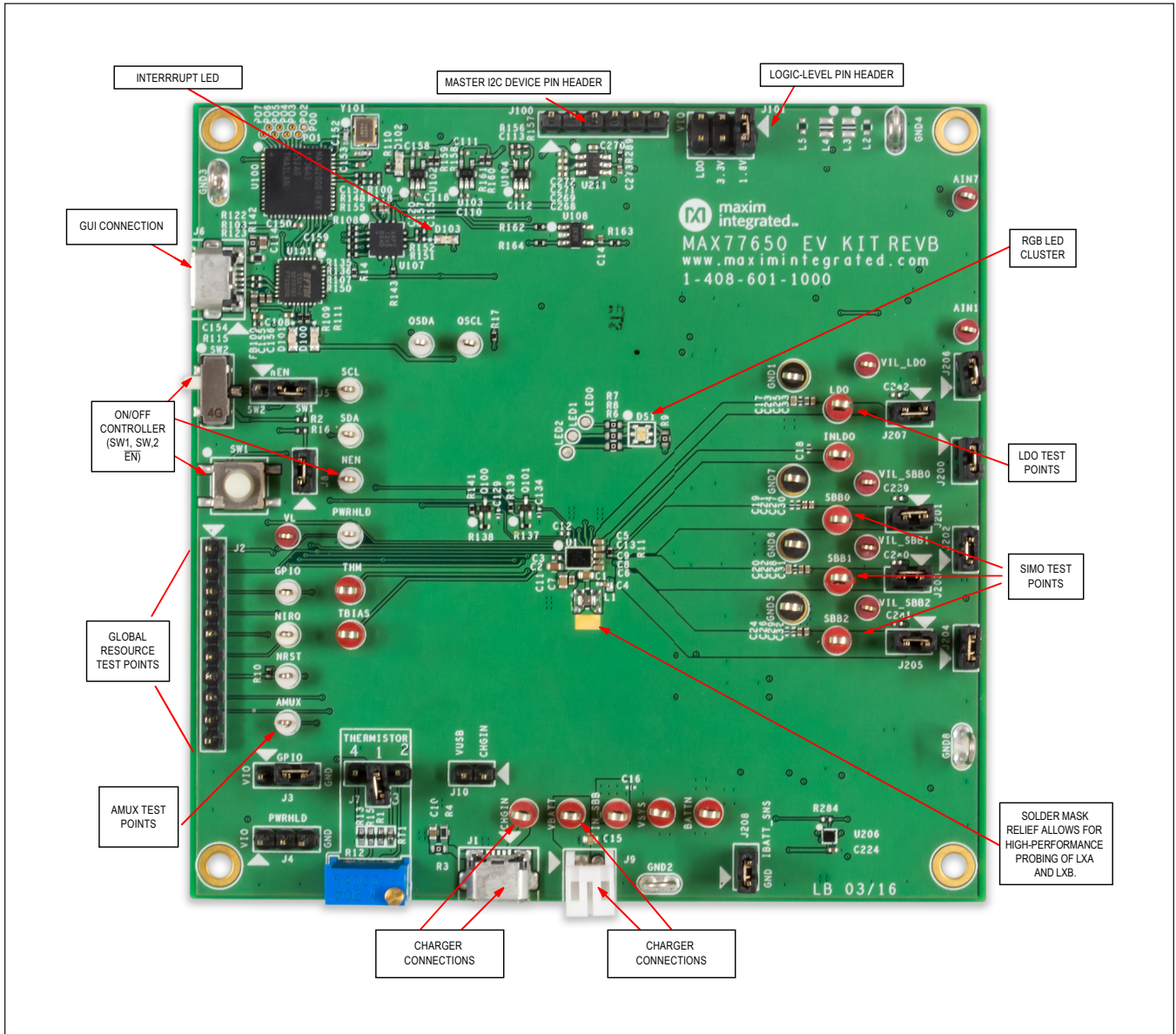

Figure 3. MAX77650 EV Kit Top View

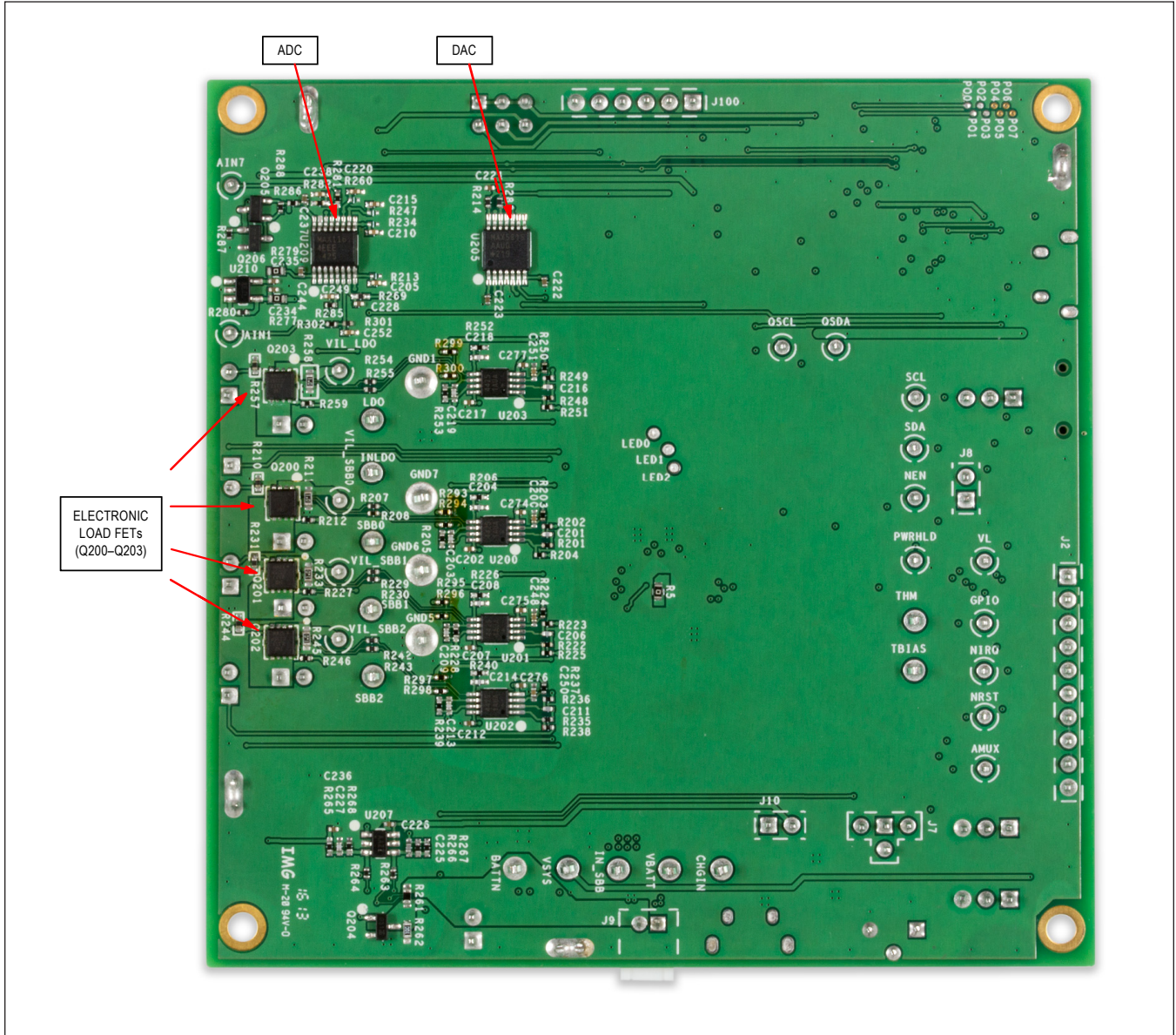

Figure 4. MAX77650 EV Kit Bottom View

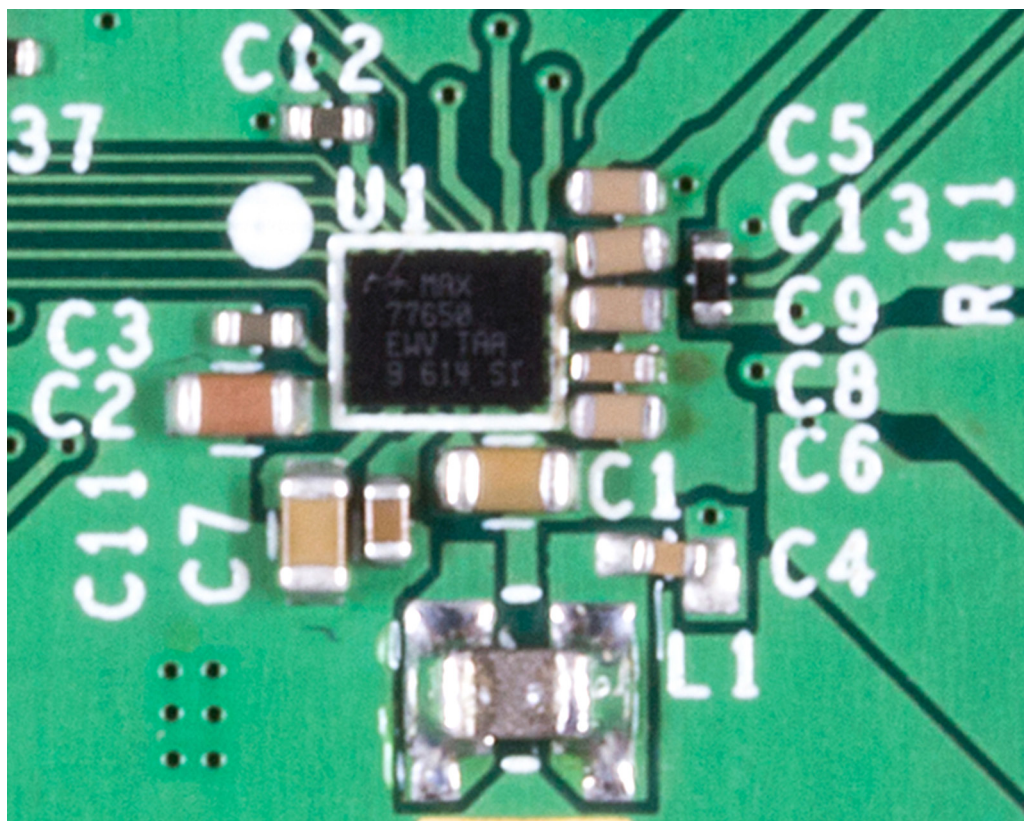

Figure 5. MAX77650 Top View Main Components

Table 1. Default Shunt Positions and Jumper Descriptions

REFERENCE DESIGNATOR	DEFAULT POSITION	FUNCTION
J100	N/A	Do not connect shunts to J100.
J101	1-2	1-2: Connects a VIO to the 1.8V EVKIT logic rail. 3-4: Connects a VIO to the 3.3V EVKIT logic rail. 5-6: Connects a VIO to the LDO output.
J200	1-2	1-2: Connects the U200 amplifier to the gate of the Q200 load FET.
J201	1-2	1-2: Connects VSBB0 to the on-board ADC.
J202	1-2	1-2: Connects the U201 amplifier to the gate of the Q201 load FET.
J203	1-2	1-2: Connects VSBB1 to the on-board ADC.
J204	1-2	1-2: Connects the U202 amplifier to the gate of the Q202 load FET.
J205	1-2	1-2: Connects VSBB2 to the on-board ADC.
J206	1-2	1-2: Connects the U203 amplifier to the gate of the Q203 load FET.
J207	1-2	1-2: Connects VLDO to the on-board ADC.
J208	1-2	1-2: Connects the on-board ammeter to GND.
J3	2-3	1-2: Connects GPIO to VIO. 2-3: Connects GPIO to GND.
J4	N/A	1-2: Connects PWR_HLD to VIO. 2-3: Connects PWR_HLD to GND.
J5	2-3	1-2: Connects \overline{EN} to SW1. 2-3: Connects \overline{EN} to SW2.
J7	1-3	1-2: Connects the THM pin to the divider through the potentiometer (R12). 1-3: Connects the THM pin to the divider through the on-board thermistor. 1-4: Connects the THM pin to the divider through a 10k resistor.
J8	1-2	1-2: Connects \overline{RST} to PWR_HLD through a 150 Ω resistor.
J10	N/A	1-2: Connects VUSB (voltage from USB input on J6) to VCHGIN.

Quick Start

Follow this procedure to familiarize yourself with the EV kit.

Note: In the following sections, software-related items are identified by bolding. Text in **bold** refers to items directly from the EV kit software. Text in **bold and underlined** refers to items from the Windows operating system.

Required Equipment

- MAX77650/MAX77651 EV kit
- Windows-based PC
- Power supply
- Ammeter
- DVM
- Micro-USB cable
- GUI

Procedure

- 1) Install the GUI software. Visit the product webpage at www.maximintegrated.com/max77650evkit and navigate to *Design Resources* to download the latest version of the EV kit software. Save the EV kit software to a temporary folder and decompress the ZIP file.
- 2) Install EV kit shunts per [Table 1](#).
- 3) Connect a Micro-B USB cable between the EV kit's J6 and your Windows-based PC. Note that a USB cable should always be plugged in during evaluation.
- 4) Apply a 3.7V supply (set for 100mA current limit) through an ammeter (set for 10mA range) across the

VBATT and GND2 terminals of the EVKIT. Turn the supply on.

- 5) Open the GUI and press the **Connect** button in the upper-left corner. Wait for the device to respond, and in the **Synchronize** window, press the **Read and close** button.
- 6) Press the **on-key** (SW1) for approximately 1 second, then release the on-key.
- 7) On the **AMUX/ADC** tab of the GUI, click the **Read** buttons next to VSBB0, VSBB1, VSBB2, and VLDO. For the MAX77650A, 2.05V, 1.2V, 3.3V, and 1.85V, respectively, appear ([Figure 6](#)). For the MAX77651B, 1.9V, 3.2V, 0V, and 0V, respectively, appear.
- 8) Confirm with the ammeter that the quiescent current is approximately 40µA. Then, in the **Global Resources** tab on the GUI, set the Main Bias Low Power Mode bit to '1' and click the **Write** button. Now, confirm that the quiescent current is approximately 6µA.

Note that the MAX77651 will have an extra 3µA current when J203 and J205 are installed. See the [MAX77650/MAX77651 EV Kit Differences](#) section for more information.

This concludes the Quick Start procedure. Users are now encouraged to explore the device and its register settings with the GUI. For guidance on configuring the charger and the LED's, see the [Charger Quick Start](#) and [LED Quick Start](#) sections. During general device evaluation, set the ammeter range to greater than or equal to 1A to minimize the impact of its series resistance.

For more information on the GUI, see the [Software](#) section.

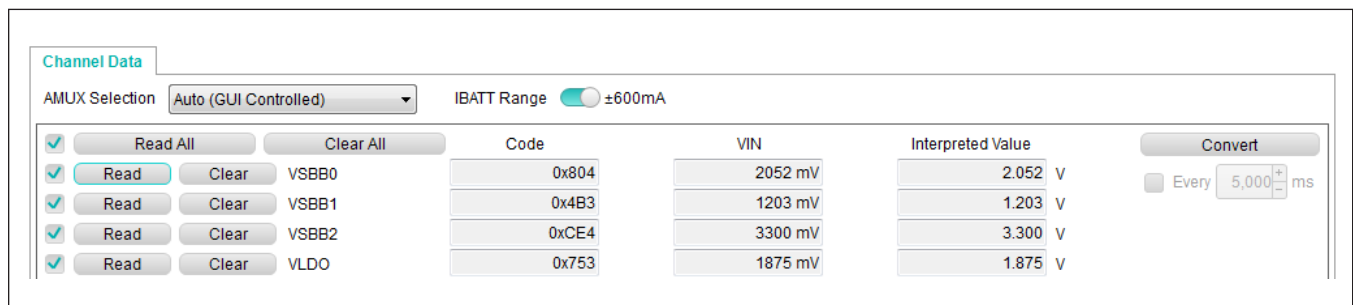

Figure 6. Quick Start: Regulator Check with the ADC

EV Kit Features

On-Key Options

For applications that require the IC to enable with a user-interactable switch, the EV kit comes with two common types: the push-button (momentary) and the slide-switch (persistent). The active-low enable pin (nEN) has an external pullup resistor R2. Select which type of switch to use with jumper J5. Refer to the MAX77650/MAX77651 data sheet for more information on configuring the IC for momentary or persistent switches.

Temperature Monitoring

Jumper J7 allows selection between the following temperature monitoring options:

- 1) Potentiometer R12 (Connect pins 1 and 2)
- 2) Fixed resistor divider R13 (Connect pins 1 and 4)
- 3) 3380K negative temperature coefficient thermistor (NTC) RT1 (Connect pins 1 and 3)

Use the potentiometer setting (pin 1 and 2) to simulate changing temperature to evaluate the charger's JEITA safe charging response. Turn the potentiometer knob counterclockwise to simulate increasing battery temperature. Turn the knob clockwise to simulate decreasing temperature. Use the resistor setting (pin 1 and 4) to set a static temperature (25°C). Use the thermistor setting (pin 1 and 3) to evaluate the charger's response to actual EVK temperature. The NTC beta parameter is 3380K. Temperature thresholds corresponding to this NTC beta are listed in [Table 2](#).

The MAX77650/MAX77651 automatically biases the temperature monitoring circuit whenever CHGIN is valid and the thermistor is enabled (THM_EN = 1), or the MUX_SEL[3:0] bitfield is connecting the THM or TBIAS pins to the AMUX output (MUX_SEL = 0b0111 or 0b1000). Refer to the *Adjustable Thermistor Temperature Monitors* section of the MAX77650/MAX77651 data sheet for more information.

Table 2. Trip Thresholds for 3380K Beta Thermistor

TRIP VOLTAGE (V)	TRIP TEMPERATURES (°C)
1.024	-10
0.976	-5
0.923	0
0.867	5
0.807	10
0.747	15
0.511	35
0.459	40
0.411	45
0.367	50
0.327	55
0.291	60

Battery Ammeter

The EV kit comes with an on-board ammeter for users to measure battery current with selectable 6mA or 600mA range. The battery current sense resistor voltage is amplified with an op-amp and then converted with an ADC. The GUI reads the ADC value and displays the corresponding current measurement. There is a removable jumper J208 (default installed, near the Li+ battery connector J9) that shorts the negative terminal of the battery to GND. To use the on-board battery ammeter, remove jumper J208 and select the desirable ammeter range (6mA or 600mA) in the AMUX/ADC tab of the GUI. Reinstall jumper J208 when not using the on-board battery ammeter. See the [Software](#) section for where to read the current value on the GUI.

Electronic Load

The EV kit comes with an electronic load that allows the user to easily evaluate the SIMO and LDO. An on-board DAC and op-amp configuration set the load current through I²C. J201, J203, J205, and J207 connect the load to the output of the SBB0, SBB1, SBB2, and LDO, respectively. Emulate SYS loading by removing J207 and connecting pin 1 of the header to VSYS with a wire. To exercise the load transient response, remove J200 (for SBB0), J202 (for SBB1), J204 (for SBB2), or J206 (for LDO) and connect a signal generator to the gate of the load MOSFET (pin 2 of the header). Drive the MOSFET gate with a signal between 1V (off) and 3V (fully on) to apply transients to the output of the SIMO or LDO. Note that there is a 1Ω sense resistor that has test point access (called VIL_SBB0, VIL_SBB1, VIL_SBB2, and VIL_LDO) that allows for a 1:1 conversion of load current to voltage. See the [Software](#) section for how to set the load current from the GUI.

On-Board ADC (MAX11614)

An on-board ADC is available to convert the output voltages of SBB0, SBB1, SBB2, and LDO. The AMUX pin of the MAX77650/MAX77651, test points AIN1 and AIN7, and battery current (IBATT) are also measured. The GUI does the appropriate conversions. See the [Software](#) section for how to read these values from the GUI.

Software

The graphical user interface (GUI) software allows for quick, easy, and thorough evaluation of the MAX77650/MAX77651.

The GUI is designed to have individual tabs for each functional block of the device (global resources, interrupts/status, GPIO, charger, SIMO buck-boost, LDO, and LED driver) and two additional tabs for controlling EV kit hardware (load control and AMUX/ADC). See [Figure 8](#) for a screenshot of the GUI upon first opening.

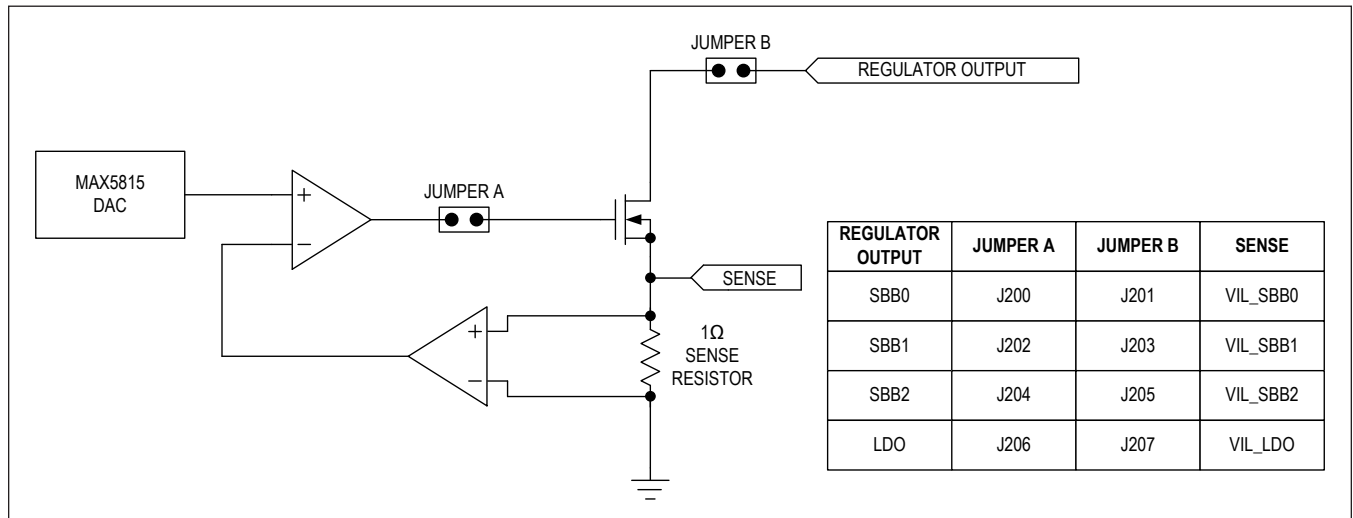

Figure 7. Electronic Load Block Diagram

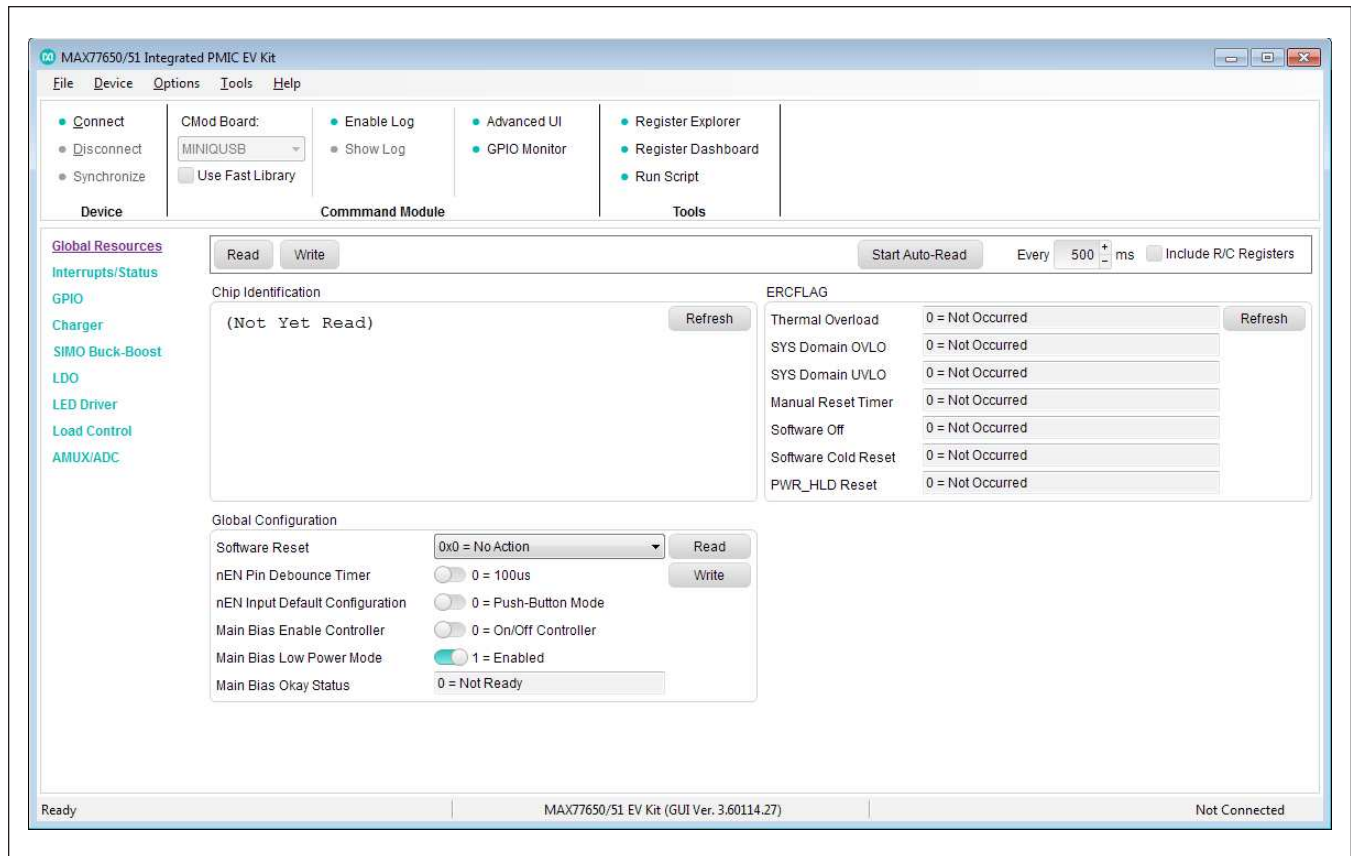

Figure 8. MAX77650/MAX77651 Evaluation Kit GUI Top-Level Interface

Installation

Visit the product webpage at www.maximintegrated.com/max77650evkit and navigate to Design Resources to download the latest version of the EV kit software. Save the EV kit software to a temporary folder and decompress the ZIP file.

Windows Drivers

Upon connection of a Micro-USB cable between your PC and the EV kit for the first time, wait a few minutes for Windows to automatically install the necessary drivers.

Graphical User Interface Details (GUI)

The GUI drives I²C communication with the EV kit. Every control in the GUI (excluding the **Load Control** and **AMUX/ADC** tabs) corresponds directly to a register within the MAX77650/MAX77651. Refer to the [Programmer's Guide](#) and IC data sheet for a complete description of

the registers. The **Load Control** and **AMUX/ADC** tabs provide additional functionality with the EV kit.

Load Control Tab

The **Load Control** tab contains controls for setting loads on the regulator outputs. The GUI is capable of setting steady-state, transient, and random load currents. To set a load current, use the slider bar or text field to input a value (mA) and click the **Enable** button. Shuffle through the modes to exercise different load conditions. The offset and gain values are set by Maxim and do not need to be altered.

AMUX/ADC Tab

The **AMUX/ADC** tab allows users to convert important voltage and current signals to digital readings. To read a signal, click the **Read** button and examine the **Interpreted Value** column.

Charger Quick Start

The **Charger** tab on the GUI has many settings to toggle; however, only three registers are needed to charge a battery. To get started with the charger, follow the procedure below:

- 1) Determine the capacity of the battery to identify a safe charge current. Maxim recommends charging at 70% of the total capacity (e.g., a 40mAh battery can be charged at 30mA charge current). Consult the battery manufacturer's data sheet carefully to determine safe charging parameters.
- 2) In Charger Configuration E/F, move the **Fast-Charge Current (IFAST_CHG)** slider to the desired charge current setting, and click the **Write** button.
- 3) In Charger Configuration G/H/I, move the **Fast-Charge Voltage (VFAST_CHG)** slider to the desired charge voltage setting, and click the **Write** button.
- 4) Make sure there is a charge source connected to the EV kit at 5V. Then, enable the charger by setting the button labeled **Charger** to '1' (Enabled) and click the **Write** button.
- 5) The battery should now be charging at the charge current set from step 2.

For more information on the capabilities of the battery charger, refer to the IC data sheet and [Programmer's Guide](#).

LED Quick Start

There is an RGB LED cluster on the EV kit, and three current sinks (LED0, LED1, and LED2). To get started with the EV kit LEDs, follow the procedure below:

- 1) Choose an LED Configuration section to change. LED0 controls Blue, LED1 controls Red, and LED2 controls Green.
- 2) The main-bias circuits must be on for the current sinks to enable. This can be accomplished by: pressing the on-key (SW1), or in the **Global Resources** tab of the GUI, setting the **Main Bias Enable Controller** bit to a '1' and click the **Write** button. Pressing the on-key will allow the internal on/off controller to enable the main-bias, while setting the GUI bit to '1' will force the main-bias circuits on.
- 3) On the **LED Driver** tab of the GUI, set the desired LED Full Scale to 3.2mA.
- 4) Set the Duty Cycle and Period to a desired blinking configuration (100% duty cycle for always-on).

- 5) Set the Brightness to 50% or adjust as needed. Click the **Write** button.
- 6) Set the **LED Master Enable** bit in LED TOP Configuration to '1'. Click the **Write** button. The LEDs should now be powered. If they are not, see step 2 of this procedure.
- 7) Adjust the settings for the other LEDs as desired.

MAX77650/MAX77651 EV Kit Differences

The MAX77650 and the MAX77651 are the same in every way except for the output voltage range of two of the SIMO outputs. The MAX77650 SBB1 output voltage range is from 0.8V to 1.5875V, whereas the MAX77651 SBB1 output voltage range is from 2.4V to 5.25V. The MAX77650 SBB2 output voltage range is from 0.8V to 3.95V, whereas the MAX77651 SBB2 output voltage range is from 2.4V to 5.25V. To expedite evaluation of these two products, Maxim offers the MAX77650EVKIT# and the MAX77651EVKIT#.

Like the devices themselves, these two EV kits are almost identical. The PCB layout and schematic are identical for both EV kits. The silkscreen designator for the part number on the PCB is different as well as the actual device (U1). As shown in the [MAX77650/MAX77651 EV Kit Component List](#), R227, R234, R246, and R247 are different for each EV kit. On the MAX77651 EV kit, these resistors scale the SBB1/SBB2 output voltages to be within the 4.096V full-scale range of the MAX11614 ADC. They also create a 1M Ω impedance path to ground, which creates additional current. To see the true quiescent current of the device, remove J203 and J205 from the EV kit.

The GUI automatically detects the device version by reading the DIDM bit. The transfer function for converting the SBB1 and SBB2 voltages are adjusted based on the version detected.

Note that the photos and layout files shown are for the MAX77650, but are directly applicable to the MAX77651.

Ordering Information

PART	IC	TYPE
MAX77650EVKIT#	MAX77650AEWV+	EV Kit
MAX77651EVKIT#	MAX77651AEWV+	EV Kit

#Denotes RoHS compliant.

MAX77650/MAX77651 EV Kit Component List

REF_DES	DNI/DNP	MAX77650EVKIT QTY	MAX77651EVKIT QTY	MFG PART #	MANUFACTURER	VALUE	DESCRIPTION
VL, AIN1, AIN7, VIL_LDO, VIL_SBB0-VIL_SBB2		7	7	5000	KEystone		TEST POINT; PIN DIA=0.1IN; TOTAL LENGTH=0.3IN; BOARD HOLE=0.04IN; RED; PHOSPHOR BRONZE WIRE SILVER PLATE FINISH;
NEN, SCL, SDA, AMUX, GPIO, NIRQ, NRST, QSQL, QSDA, PWRHLD		10	10	5002	KEystone		TEST POINT; PIN DIA=0.1IN; TOTAL LENGTH=0.3IN; BOARD HOLE=0.04IN; WHITE; PHOSPHOR BRONZE WIRE SILVER;
LDO, THM, SBB0-SBB2, VSYS, BATTN, CHGIN, INLDO, TBIAS, VBATT, IN_SBB		12	12	5010	KEystone		TESTPOINT WITH 1.80MM HOLE DIA, RED, MULTIPURPOSE;
C1, C11, C15		3	3	GRM188R61 A226ME15D	MURATA	22UF	CAPACITOR; SMT (0603); CERAMIC CHIP; 22UF; 10V; TOL=20%; MODEL=CL SERIES; TG=-55 DEGC TO +85 DEGC; TC=X5R; FORMFACTOR
C2		1	1	GRM188R61 E475KE11D	MURATA	4.7UF	CAPACITOR; SMT (0603); CERAMIC CHIP; 4.7UF; 25V; TOL=10%; TG=-55 DEGC TO +85 DEGC; TC=X5R
C3, C12, C110-C113, C115, C118, C120, C158, C239-C242		14	14	GRM155R60J 105KE19D	MURATA	1UF	CAPACITOR; SMT (0402); CERAMIC CHIP; 1UF; 6.3V; TOL=20%; MODEL=C SERIES; TG=-55 DEGC TO +85 DEGC; TC=X5R ; FORMFACTOR
C4		1	1	GRM155R71 H332KA01D	MURATA	3300PF	CAPACITOR; SMT (0402); CERAMIC CHIP; 3300PF; 50V; TOL=10%; TG=-55 DEGC TO +85 DEGC; TC=X5R
C5, C6, C8, C9, C13, C17, C20		7	7	GRJ155R60J1	MURATA	10UF	CAPACITOR; SMT (0402); CERAMIC CHIP; 10UF; 6.3V; TOL=20%; MODEL=; TG=-55 DEGC TO +85 DEGC; TC=X5R; FORMFACTOR
C7, C154		2	2	ZRB15XR61A4	MURATA	4.7UF	CAPACITOR; SMT (0402); CERAMIC CHIP; 4.7UF; 10V; TOL=20%; MODEL=C SERIES; TG=-55 DEGC TO +85 DEGC; TC=X5R; FORMFACTOR
C10, C114		2	2	GRM188R61 A474KA61D	MURATA	0.47UF	CAPACITOR; SMT; 0603; CERAMIC; 0.47uF; 10V; 10%; X5R; -55degC to +125degC; ; FORMFACTOR
C14, C108, C150, C151, C155-C157, C159, C202, C207, C212, C217, C221-C224, C226, C234-C237, C244, C268, C272-C277		29	29	GRM155R61E	MURATA	0.1UF	CAPACITOR; SMT (0402); CERAMIC CHIP; 0.1UF; 25V; TOL=10%; MODEL=C SERIES; TG=-55 DEGC TO +125 DEGC; TC=X7R; FORMFACTOR
C16,C18,C19,C21-C24,C26,C129,C134	Do not install	10	10			OPEN	CAPACITOR; SMT (0402); OPEN; FORMFACTOR

MAX77650/MAX77651 EV Kit Component List (continued)

REF_DES	DNI/DNP	MAX77650EVKIT QTY	MAX77651EVKIT QTY	MFG PART #	MANUFACTURER	VALUE	DESCRIPTION
C25, C27-C29		4	4	GRM155R61A	MURATA	0.1UF	CAPACITOR; SMT; 0402; CERAMIC; 0.1uF; 10V; 10%; X5R; -55degC to + 125degC; 0 +/- 30PPM/degC; FORMFACTOR ;
C30-C33		4	4	GRM155R61A103KA01D	MURATA	0.01UF	CAPACITOR; SMT (0402); CERAMIC CHIP; 0.01UF; 10V; TOL=10%; MODEL=C0402C SERIES; TG=-55 DEGC TO +125 DEGC; TC=X7R
C152, C153		2	2	GRM1555C1H150FA01	MURATA	15PF	CAPACITOR; SMT (0402); CERAMIC CHIP; 15PF; 50V; TOL=1%; TG=-55 DEGC TO +125 DEGC; TC=C0G
C200, C205, C210, C215, C220, C238, C248-C252		11	11	GRM155R71H472KA01D	MURATA	4700PF	CAPACITOR; SMT (0402); CERAMIC CHIP; 4700PF; 50V; TOL=10%; TG=-55 DEGC TO +85 DEGC; TC=X5R
C201, C206, C211, C216		4	4	GRM155R71H	MURATA	1000PF	CAPACITOR; SMT (0402); CERAMIC CHIP; 1000PF; 50V; TOL=10%; MODEL=C0G; TG=-55 DEGC TO +125 DEGC; TC=+; FORMFACTOR
C203, C204, C208, C209, C213, C214, C218, C219		8	8	C0402C180J5GAC; GRM1555C1H180JA01J;C1005COG1H180J050	KEMET/MURATA/TDK	18PF	CAPACITOR; SMT (0402); CERAMIC CHIP; 18PF; 50V; TOL=5%; TG=-55 DEGC TO +125 DEGC; TC=C0G
C225		1	1	GRM1555C1H331GA01;C1005COG1H331G050	MURATA/TDK	330PF	CAPACITOR; SMT (0402); CERAMIC CHIP; 330PF; 50V; TOL=2%; TG=-55 DEGC TO +125 DEGC; TC=C0G
C227		1	1	GRM1555C1H181GA01	MURATA	180PF	CAPACITOR; SMT (0402); CERAMIC CHIP; 180PF; 50V; TOL=2%; TG=-55 DEGC TO +125 DEGC; TC=C0G
C228		1	1	GRM155R61A	MURATA	1UF	CAPACITOR; SMT (0402); CERAMIC CHIP; 1UF; 10V; TOL=10%; MODEL=; TG=-55 DEGC TO +85 DEGC; TC=X5R; FORMFACTOR
C269-C271		3	3	GRM155R61C105KE01D	MURATA	1UF	CAPACITOR; SMT (0402); CERAMIC CHIP; 1UF; 16V; TOL=10%; MODEL=C SERIES; TG=-55 DEGC TO +85 DEGC; TC=X5R; FORMFACTOR
D100, D101		2	2	LTST-C190YKT	LITE-ON ELECTRONICS; INC.	LTST-C190YKT	DIODE; LED; STANDARD; YELLOW; SMT (0603); PIV=5.0V; IF=0.02A; -55 DEGC TO +85 DEGC
D102, D103		2	2	LTST-C190CKT	LITE-ON ELECTRONICS; INC.	LTST-C190CKT	DIODE; LED; STANDARD; RED; SMT (0603); PIV=5.0V; IF=0.04A; -55 DEGC TO +85 DEGC
DS1		1	1	19-337/R6GHBH C-A01/2T	EVERLIGHT	19-337/R6GHBH C-A01/2T	DIODE; LED; SMD-B; RED/GREEN/BLUE; SMT; PIV=2V-3.3V; IF=0.02A
FB100		1	1	BLM18PG221SN1	MURATA	220	INDUCTOR; SMT (0603); FERRITE-BEAD; 220; TOL=+/- 25%; 1.4A; -55 DEGC TO +125 DEGC

MAX77650/MAX77651 EV Kit Component List (continued)

REF_DES	DNI/DNP	MAX77650EVKIT QTY	MAX77651EVKIT QTY	MFG PART #	MANUFACTURER	VALUE	DESCRIPTION
GND1, GND5-GND7		4	4	5011	KEYSTONE		TEST POINT; PIN DIA=0.125IN; TOTAL LENGTH=0.445IN; BOARD HOLE=0.063IN; BLACK; PHOSPHOR BRONZE WIRE SILVER PLATE FINISH;
GND2-GND4, GND8		4	4	9020 BUSS	WEICO WIRE	MAXIMPAD	EVK KIT PARTS; MAXIM PAD; WIRE; NATURAL; SOLID; WEICO WIRE; SOFT DRAWN BUS TYPE- S; 20AWG
J1, J6		2	2	10103592- 0001LF	FCI CONNECT	10103592- 0001LF	CONNECTOR; FEMALE; SMT; MICRO USB B-TYPE REVERSE; RIGHT ANGLE; 5PINS
J2		1	1	PBC10SAAN	SULLINS ELECTRONICS CORP.	PBC10SAAN	CONNECTOR; MALE; THROUGH HOLE; BREAKAWAY; STRAIGHT; 10PINS; -65 DEGC TO +125 DEGC
J3-J5		3	3	TSW-103-07- T-S	SAMTEC	TSW-103-07-T- S	CONNECTOR; THROUGH HOLE; TSW SERIES; SINGLE ROW; STRAIGHT; 3PINS
J7		1	1	PEC04SAAN	SULLINS ELECTRONICS CORP.	PEC04SAAN	CONNECTOR; MALE; THROUGH HOLE; BREAKAWAY; STRAIGHT; 4PINS
J8, J10, J200-J208		11	11	TSW-102-07- T-S	SAMTEC	TSW-102-07-T- S	CONNECTOR; THROUGH HOLE; TSW SERIES; SINGLE ROW; STRAIGHT; 2PINS; -55 DEGC TO +105 DEGC
J9		1	1	S2B-PH-K- S(LF)(SN)	JST MANUFACTURING	S2B-PH-K- S(LF)(SN)	CONNECTOR; MALE; THROUGH HOLE; 2.0MM PITCH; DISCONNECTABLE CRIMP STYLE CONNECTOR; SIDE ENTRY TYPE; RIGHT ANGLE; 2PINS
J100		1	1	PBC06SAAN	SULLINS ELECTRONICS CORP.	PBC06SAAN	CONNECTOR; MALE; THROUGH HOLE; BREAKAWAY; STRAIGHT; 6PINS; -65 DEGC TO +125 DEGC
J101		1	1	TSW-102-26- T-T	SAMTEC	TSW-102-26-T- T	CONNECTOR; THROUGH HOLE; TSW SERIES; TRIPLE ROW; STRAIGHT; 6PINS
L1		1	1	DFE201210U- 1R5M=P2	TOKO	1.5UH	EVKIT PART-INDUCTOR; SMT (0805); METAL ALLOY CHIP; 1.5UH; TOL=+/-20%; 1.9A; 2.00MMX1.20MMX1.00MM
L3		1	1	CIGT201208E H2R2MN	SAMSUNG ELECTRONICS	2.2UH	EVKIT PART-INDUCTOR; SMT (0805); METAL COMPOSITE CORE; 2.2UH; TOL=+/-20%; 1.8A; 2.00MMX1.25MMX0.80MM
L4		1	1	CIGT201610E H2R2MN	SAMSUNG ELECTRONICS	2.2UH	EVKIT PART-INDUCTOR; SMT (0806); METAL COMPOSITE CORE; 2.2UH; TOL=+/-20%; 2.7A; 2.00MMX1.60MMX1.00MM
L5		1	1	DFE252007F- 2R2M=P2	MURATA	2.2UH	EVKIT PART-INDUCTOR; SMT (1008); METAL ALLOY CHIP; 2.2UH; TOL=+/-20%; 1.7A; 2.50MMX2.00MMX0.70MM

MAX77650/MAX77651 EV Kit Component List (continued)

REF_DES	DNI/DNP	MAX77650EVKIT QTY	MAX77651EVKIT QTY	MFG PART #	MANUFACTURER	VALUE	DESCRIPTION
Q100, Q101		2	2	FDY300NZ	FAIRCHILD SEMICONDUCTOR	FDY300NZ	TRAN; SINGLE N-CHANNEL 2.5V SPECIFIED POWERTRENCH MOSFET; NCH; SC89; PD- (0.625W); I-(0.6A); V-(20V)
Q200-Q203		4	4	IRFHM8337T RPBF	INTERNATIONAL RECTIFIER	IRFHM8337TR PBF	TRAN; HEXFET POWER MOSFET; NCH; PQFN8; PD-(2.8W); I- (18A); V-(30V)
Q204		1	1	DMG3420U	DIODES INCORPORATED	DMG3420U	TRAN; N-CHANNEL ENHANCEMENT MODE MOSFET; NCH; SOT-23; PD-(0.74W); I- (5.47A); V-(20V)
Q205		1	1	FDN360P	FAIRCHILD SEMICONDUCTOR	FDN360P	TRANSISTOR, MOSFET P- CHANNEL, SUPERSOT-3, PD=0.5W, ID=-2.0A, VDSS=- 30V, V _{GSS} =+/-20V
Q206		1	1	2N7002		2N7002	TRAN; ; NCH; SOT-23; PD- (0.33W); IC-(0.5A); V _{CEO} -(60V); - 55 DEGC TO +150 DEGC
R1, R2, R10, R13, R15, R281, R282, R287, R288		9	9	CRCW04021 0K0FK; RC0402FR- 0710K	VISHAY DALE; YAGEO PHICOMP	10K	RESISTOR; 0402; 10K; 1%; 100PPM; 0.0625W; THICK FILM
R3, R5-R9, R142, R277, R279		9	9			0	RESISTOR; 0603; 0 OHM; 0%; JUMPER; 0.10W; THICK FILM; FORMFACTOR
R4, R122		2	2			1M	RESISTOR; 0603; 1M; 1%; 100PPM; 0.10W; THICK FILM; FORMFACTOR
R11, R17, R135, R136, R139, R141, R143, R148, R152, R155, R162-R164, R204, R212, R225, R238, R251, R259, R285, R286, R302-R306		26	26			0	RESISTOR; 0402; 0 OHM; 1%; 100PPM; 0.0625W; THICK FILM; FORMFACTOR
R12		1	1	3296Y-1- 204LF	BOURNS	200K	RESISTOR; THROUGH HOLE- RADIAL LEAD; 3296 SERIES; 200K OHM; 10%; 100PPM; 0.5W
R14, R115, R157, R159, R161, R214, R280, R283		8	8			100K	RESISTOR; 0402; 100K; 1%; 100PPM; 0.0625W; THICK FILM; FORMFACTOR
R16, R151		2	2	CRCW04021 50RFK; 9C04021A15 00FL	VISHAY DALE	150	RESISTOR; 0402; 150 OHM; 1%; 100PPM; 0.0625W; THICK FILM
R100, R118		2	2			4.7K	RESISTOR, 0402, 4.7K OHM, 1%, 100PPM, 0.0625W, THICK FILM; FORMFACTOR
R103, R123, R150		3	3			22	RESISTOR, 0402, 22 OHM, 1%, 100PPM, 0.0625W, THICK FILM; FORMFACTOR
R107, R108		2	2			2.2K	RESISTOR, 0402, 2.2K OHM, 1%, 100PPM, 0.0625W, THICK FILM; FORMFACTOR
R109, R111		2	2			100	RESISTOR; 0402; 100 OHM; 1%; 100PPM; 0.0625W; THICK FILM; FORMFACTOR
R110		1	1	CRCW04024 70RFK	VISHAY DALE	470	RESISTOR, 0402, 470 OHM, 1%, 100PPM, 0.0625W, THICK FILM
R137, R138		2	2			49.9	RESISTOR; 0402; 49.9 OHM; 1%; 100PPM; 0.0625W; THICK FILM; FORMFACTOR

MAX77650/MAX77651 EV Kit Component List (continued)

REF_DES	DNI/DNP	MAX77650EVKIT QTY	MAX77651EVKIT QTY	MFG PART #	MANUFACTURER	VALUE	DESCRIPTION
R156		1	1	CRCW04021 05KFK	VISHAY DALE	105K	RESISTOR; 0402; 105K OHM; 1%; 100PPM; 0.063W ; THICK FILM
R158		1	1	CRCW04021 69KFK	VISHAY DALE	169K	RESISTOR; 0402; 169K OHM; 1%; 100PPM; 0.063W; THICK FILM
R160		1	1	CRCW04024 752FK; 9C04021A47 52FLHF3; CRCW04024 7K5FK	VISHAY DALE	47.5K	RESISTOR; 0402; 47.5K; 1%; 100PPM; 0.0625W; THICK FILM
R201, R222, R235, R248, R289		5	5	CRCW04021 00RFK; 9C04021A10 00FL; RC0402FR- 07100RL	VISHAY DALE; PANASONIC; YAGEO PHYCOMP	100	RESISTOR; 0402; 100 OHM; 1%; 100PPM; 0.063W; THICK FILM
R202, R223, R236, R249		4	4	CRCW04026 80RFK;RC040 2FR-07680RL	VISHAY DALE/YAGEO PHICOMP	680	RESISTOR, 0402, 680 OHM, 1%, 100PPM, 0.0625W, THICK FILM
R203, R224, R237, R250		4	4	CRCW04022 0K0FK	VISHAY DALE	20K	RESISTOR; 0402; 20K OHM; 1%; 100PPM; 0.063W; THICK FILM
R205, R206, R226, R228, R239, R240, R252, R253		8	8	CRCW04024 991FK	VISHAY DALE	4.99K	RESISTOR; 0402; 4.99K; 1%; 100PPM; 0.0625W; THICK FILM
R207, R208, R229, R230, R242, R243, R254, R255, R263, R264		10	10			1K	RESISTOR; 0402; 1K; 1%; 100PPM; 0.0625W; THICK FILM; FORMFACTOR
R210, R231, R244, R257, R301		5	5	CRCW04021 M00FK	VISHAY DALE	1M	RESISTOR; 0402; 1M; 1%; 100PPM; 0.0625W; THICK FILM
R211, R233, R245, R258		4	4	ERJ- 3RQF1ROV	PANASONIC	1	RESISTOR, 0603, 1 OHM, 1%, 100PPM, 0.10W, THICK FILM
R213,R260	Do not install	2	2			OPEN	RESISTOR; 0402; OPEN; FORMFACTOR
R227(MAX77650)		1	0			0	RESISTOR; 0402; 0 OHM; 1%; 100PPM; 0.0625W; THICK FILM; FORMFACTOR
R227(MAX77651)		0	1	CRCW04025 10KJN	VISHAY DALE	510K	RESISTOR; 0402; 510K OHM; 5%; 200PPM; 0.063W; METAL FILM
R234(MAX77650)	Do not install	0	0			OPEN	RESISTOR; 0402; OPEN; FORMFACTOR
R234(MAX77651)		0	1	CRCW04025 10KJN	VISHAY DALE	510K	RESISTOR; 0402; 510K OHM; 5%; 200PPM; 0.063W; METAL FILM
R246(MAX77650)		1	0			0	RESISTOR; 0402; 0 OHM; 1%; 100PPM; 0.0625W; THICK FILM; FORMFACTOR
R246(MAX77651)		0	1	CRCW04025 10KJN	VISHAY DALE	510K	RESISTOR; 0402; 510K OHM; 5%; 200PPM; 0.063W; METAL FILM
R247(MAX77650)	Do not install	0	0			OPEN	RESISTOR; 0402; OPEN; FORMFACTOR
R247(MAX77651)		0	1	CRCW04025 10KJN	VISHAY DALE	510K	RESISTOR; 0402; 510K OHM; 5%; 200PPM; 0.063W; METAL FILM
R261		1	1	CSR0603FKR 100	STACKPOLE ELECTRONICS INC	0.1	RESISTOR; 0603; 0.1 OHM; 1%; 300PPM; 0.125W; THICK FILM

MAX77650/MAX77651 EV Kit Component List (continued)

REF_DES	DNI/DNP	MAX77650EVKIT QTY	MAX77651EVKIT QTY	MFG PART #	MANUFACTURER	VALUE	DESCRIPTION
R262		1	1	CRCW060310R0FK; MCR03EZPFX 10R0	VISHAY DALE/ROHM	10	RESISTOR; 0603; 10 OHM; 1%; 100PPM; 0.10W; THICK FILM
R265-R268		4	4	CRCW040264K9FK	VISHAY DALE	64.9K	RESISTOR; 0402; 64.9K OHM; 1%; 100PPM; 0.063W; METAL FILM
R269		1	1	CRCW04021K00FK; RC0402FR-071KL	VISHAY DALE; YAGEO PHICOMP	1K	RESISTOR; 0402; 1K; 1%; 100PPM; 0.0625W; THICK FILM
R284		1	1	CRCW0402100KFK; RC0402FR-07100KL	VISHAY DALE; YAGEO PHICOMP	100K	RESISTOR; 0402; 100K; 1%; 100PPM; 0.0625W; THICK FILM
R293, R295, R297, R299		4	4	ERJ-2RKF4703X	PANASONIC	470K	RESISTOR, 0402, 470K OHM, 1%, 100PPM, 0.0625W, THICK FILM
R294, R296, R298, R300		4	4	CRCW0402649KFK	VISHAY DALE	649K	RESISTOR; 0402; 649K OHM; 1%; 100PPM; 0.063W; THICK FILM
RT1		1	1	NCP15XH103F03RC	MURATA	10K	THERMISTOR; SMT (0402); THICK FILM (NICKEL PLATED); 10K; TOL=+/-1%
SW1		1	1	EVQ-Q2K03W	PANASONIC	EVQ-Q2K03W	SWITCH; SPST; SMT; 15V; 0.02A; LIGHT TOUCH SWITCH; RCOIL= OHM; RINSULATION= OHM; PANASONIC
SW2		1	1	CL-SB-12B-11	NIDEC COPAL ELECTRONICS CORP	CL-SB-12B-11	SWITCH; SPDT; SMT; 12V; 0.02A; CL-SB SERIES; SLIDE SWITCH; RCOIL=0.05 OHM; RINSULATION=100M OHM; NIDEC COPAL ELECTRONICS CORP
U1(MAX77650)		1	0	MAX77650A EWW+	MAXIM	MAX77650	EVKIT PART-IC; WLP30; PACKAGE CODE: W302H2+1; CL30
U1(MAX77651)		0	1	MAX77651A EWW+	MAXIM	MAX77651	EVKIT PART-IC; WLP30; PACKAGE CODE: W302H2+1; CL30
U100		1	1	MAXQ2000- RBX+	MAXIM	MAXQ2000- RBX+	IC; CTRL; LOW-POWER LCD MICROCONTROLLER; TQFN56-EP 8X8
U101		1	1	FT232RQ	FUTURE TECHNOLOGY DEVICES INTL LTD.	FT232RQ	IC; INFC; UART INTERFACE IC USB TO SERIAL; QFN32-EP 5X5
U102-U104		3	3	MAX8512EX K	MAXIM	MAX8512EXK	IC, VREG, Ultra-Low-Noise, High PSRR, Adjustable Vout, SC70-5
U107		1	1	MAX3395EET C	MAXIM	MAX3395EET C	IC; TRANS; 15KV ESD-PROTECTED HIGH-DRIVE CURRENT QUAD-LEVEL TRANSLATOR WITH SPEED-UP CIRCUITRY; TQFN12 4X4
U108		1	1	24AA02T- I/OT	MICROCHIP	24AA02T-I/OT	IC; EPROM; 2K I2C SERIAL EEPROM; SOT23-5
U200-U203		4	4	MAX44251A UA+	MAXIM	MAX44251AU A+	IC; OPAMP; ULTRA-PRECISION; LOW-NOISE OP AMP; UMAX8
U205		1	1	MAX5815AA UD+	MAXIM	MAX5815AAU D+	IC; DAC; ULTRA-SMALL; QUAD-CHANNEL; 12-BIT BUFFERED OUTPUT DAC WITH INTERNAL REFERENCE AND I2C INTERFACE; TSSOP14

MAX77650/MAX77651 EV Kit Component List (continued)

REF_DES	DNI/DNP	MAX77650EVKIT QTY	MAX77651EVKIT QTY	MFG PART #	MANUFACTURER	VALUE	DESCRIPTION
U206		1	1	MAX14689E WL+	MAXIM	MAX14689E WL+	IC; ASW; 0.125A; FREQUENCY- SELECTSBLE; SWITCHED- CAPACITOR VOLTAGE CONVERTER; WLP9 1.2X1.2
U207		1	1	MAX4238AU T+	MAXIM	MAX4238AU +	IC; OPAMP; IC; ULTRA-LOW OFFSET/DRIFT; LOW-NOISE; PRECISION SOT23 AMPLIFIER; SOT23-6
U209		1	1	MAX11614E EE+	MAXIM	MAX11614EE E+	IC; ADC; LOW-POWER; 8- CHANNEL; I2C; 12-BIT ADC IN ULTRA-SMALL PACKAGE; QSOP16
U210		1	1	MAX6037BA UK41+	MAXIM	MAX6037BAU K41+	IC; VREF; LOW-POWER; FIXED; ADJUSTABLE REFERENCE WITH SHUTDOWN; SOT23-5
U211		1	1	MAX1697UE UT+	MAXIM	MAX1697UEU T+	IC; INV; INVERTING CHARGE PUMP WITH SHUTDOWN; SOT23-6
Y101		1	1	CX3225SB16 000D0FLJZZ	KYOCERA-KINSEKI	16MHZ	CRYSTAL; SMT (3225) 3.2X2.5; 8PF; 16MHZ; +/-10PPM; +/- 15PPM
L2	DNP	0	0	MLP1608VR4 7D	TDK	0.47UH	INDUCTOR; SMT (0603); SHIELDED; 0.47UH; TOL=+/- 0.3nH; 0.8A
PCB		1	1	CL30_MAX77 651	MAXIM	PCB	PCB: MAX77651 EVKIT

MAX77650/MAX77651 EV Kit Schematic

Part Number	Configuration	7-bit	8-bit Write	8-bit Read
MAX77650 (PMIC)	ADDR OTP bit set for 0	0x40 0b100 0000	0x80 0b1000 0000	0x81 0b1000 0001
MAX77650 (PMIC)	ADDR OTP bit set for 1	0x48 0b100 1000	0x90 0b1001 0000	0x91 0b1001 0001
MAX77650 (PMIC)	Maxim internal test mode	0x49 0b100 1001	0x92 0b1001 0010	0x93 0b1001 0011
MAX11614 (ADC)	N/A	0x33 0b011 0011	0x66 0b0110 0110	0x67 0b0110 0111
MAX5815 (DAC)	ADDR1=ADDR0=GND	0x1F 0b001 1111	0x3E 0b0011 1110 0x10* 0b0001 0000	0x3F 0b0011 1111
24AA02 (EEPROM)	N/A	0x50 to 0x57 0b1010xxx	0b1010xxx0	0b1010xxx1

*MAX5815 ALSO RESPONDS TO AN I2C BROADCAST ADDRESS 0b0001 0000

Figure 9. MAX77650/MAX77651 EV Kit Schematic (1 of 6)

MAX77650/MAX77651 EV Kit Schematic (continued)

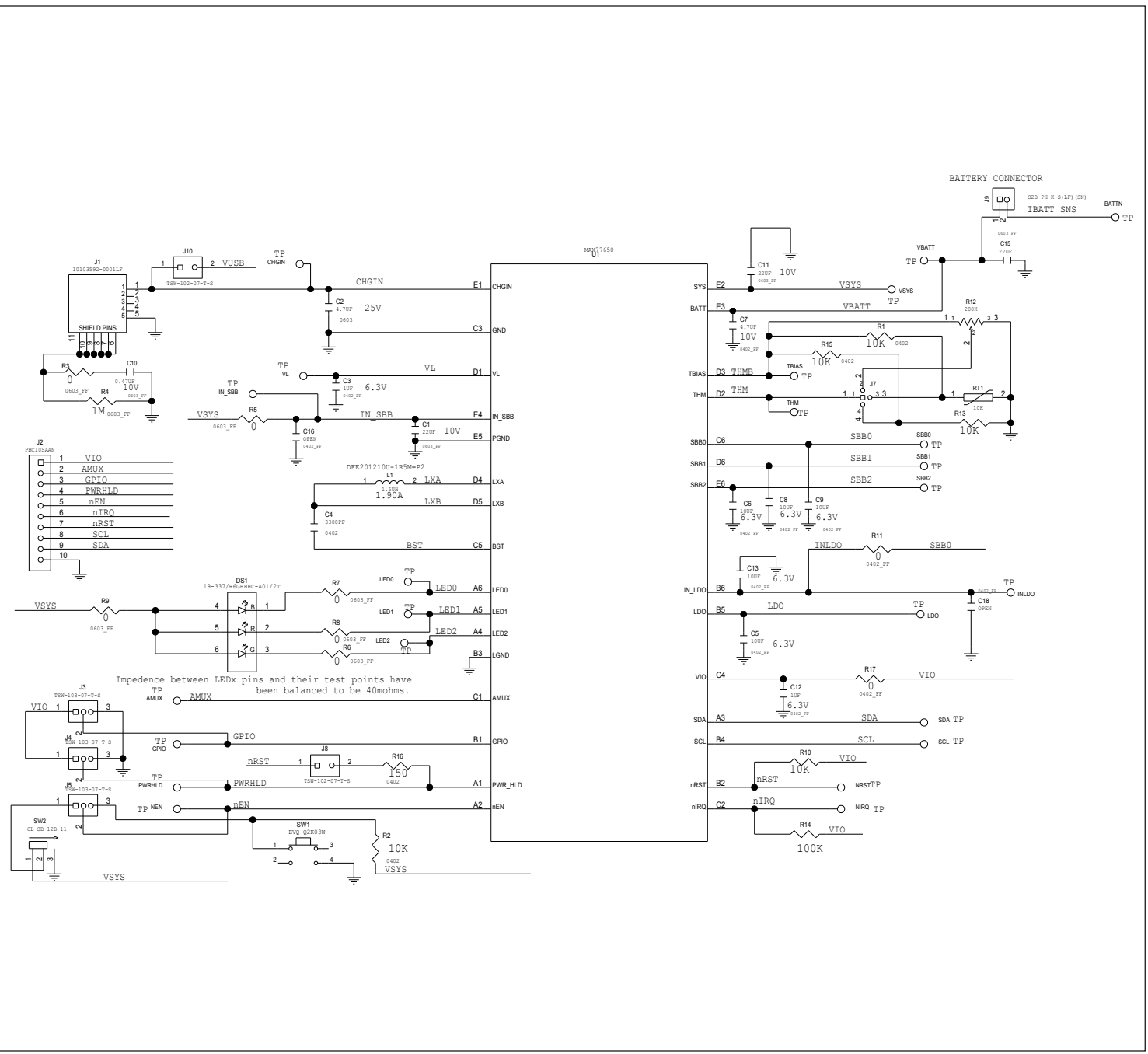

Figure 10. MAX77650/MAX77651 EV Kit Schematic (2 of 6)

MAX77650/MAX77651 EV Kit Schematic (continued)

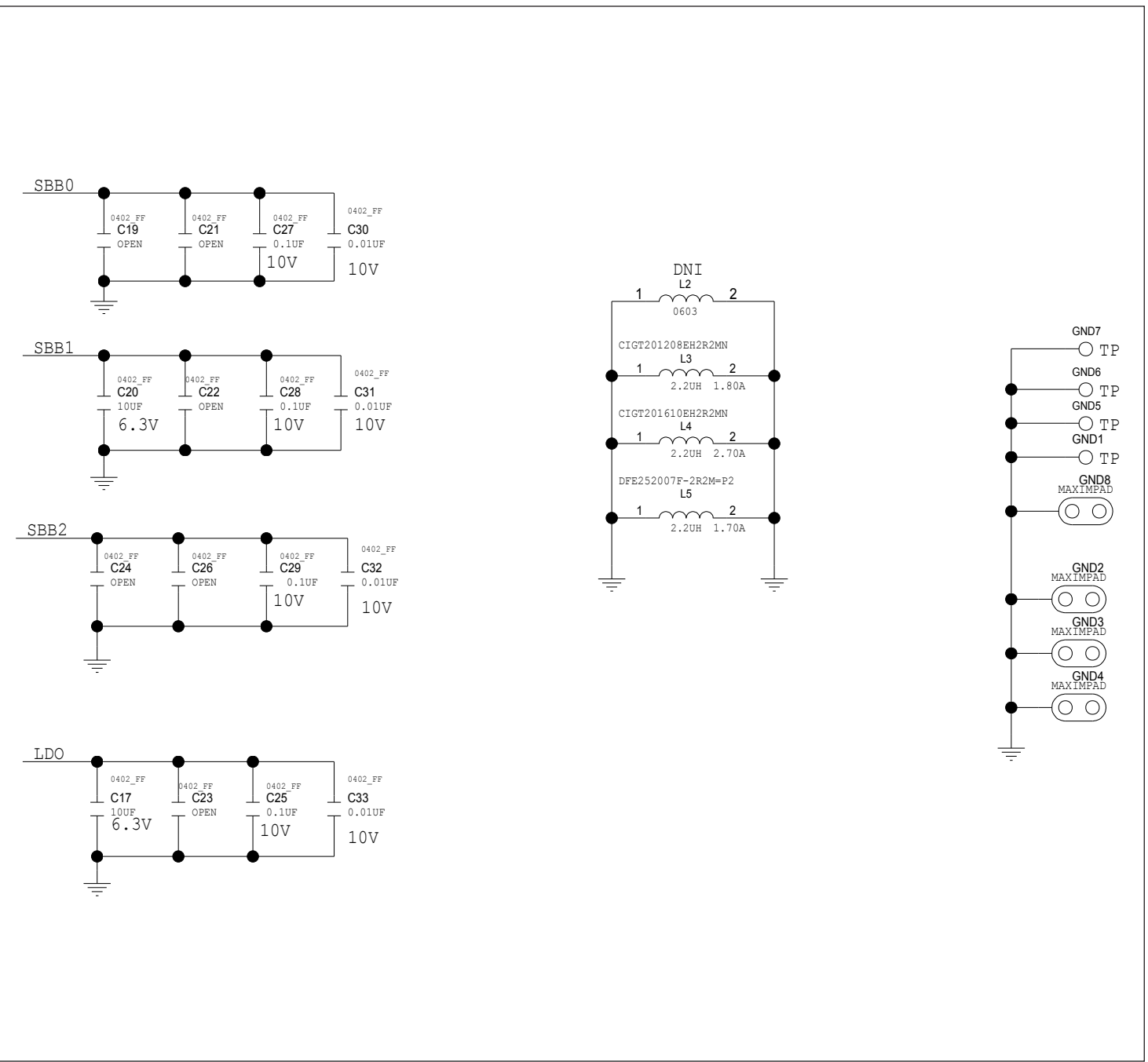

Figure 11. MAX77650/MAX77651 EV Kit Schematic (3 of 6)

MAX77650/MAX77651 EV Kit Schematic (continued)

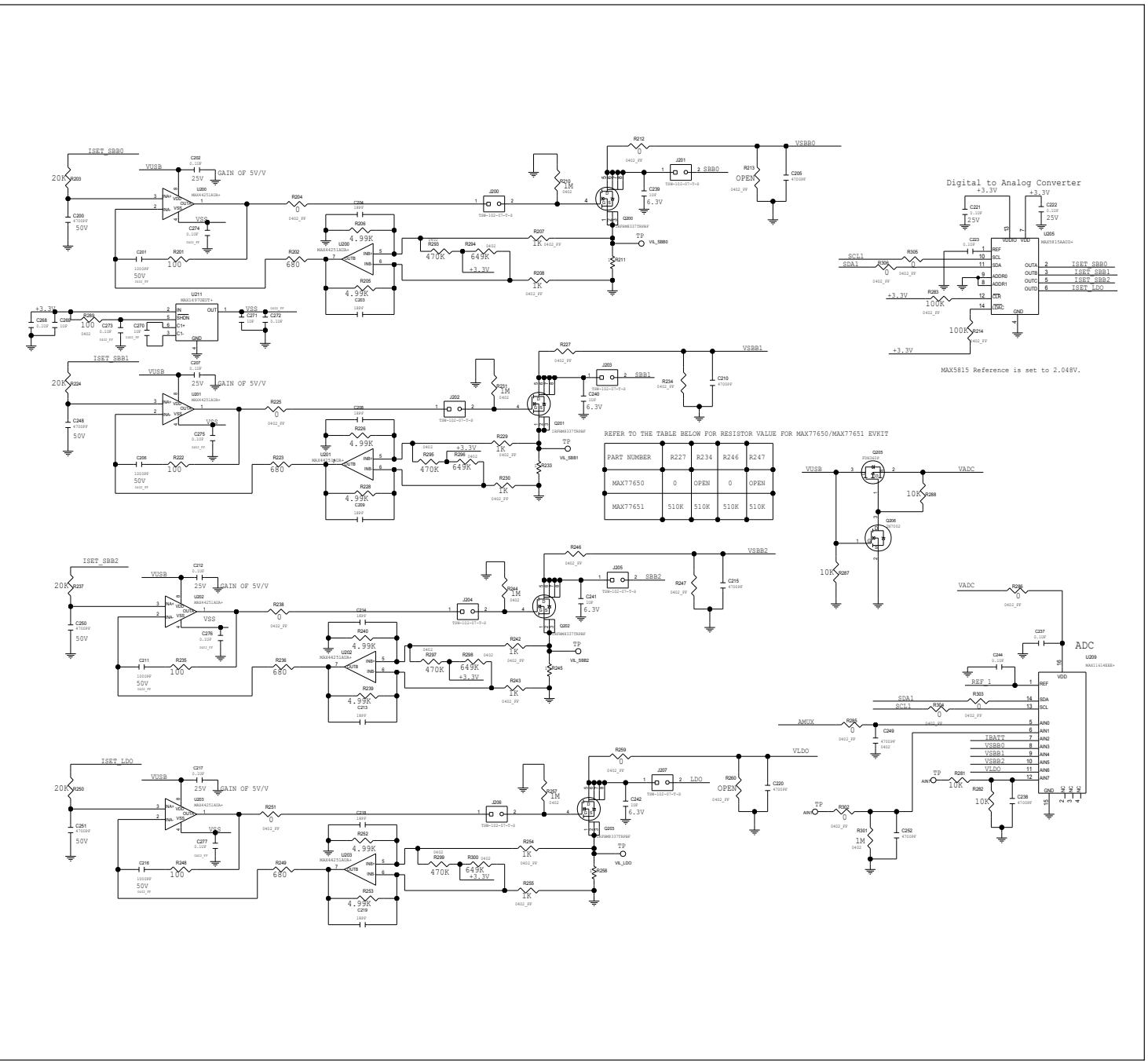

Figure 12. MAX77650/MAX77651 EV Kit Schematic (4 of 6)

MAX77650/MAX77651 EV Kit Schematic (continued)

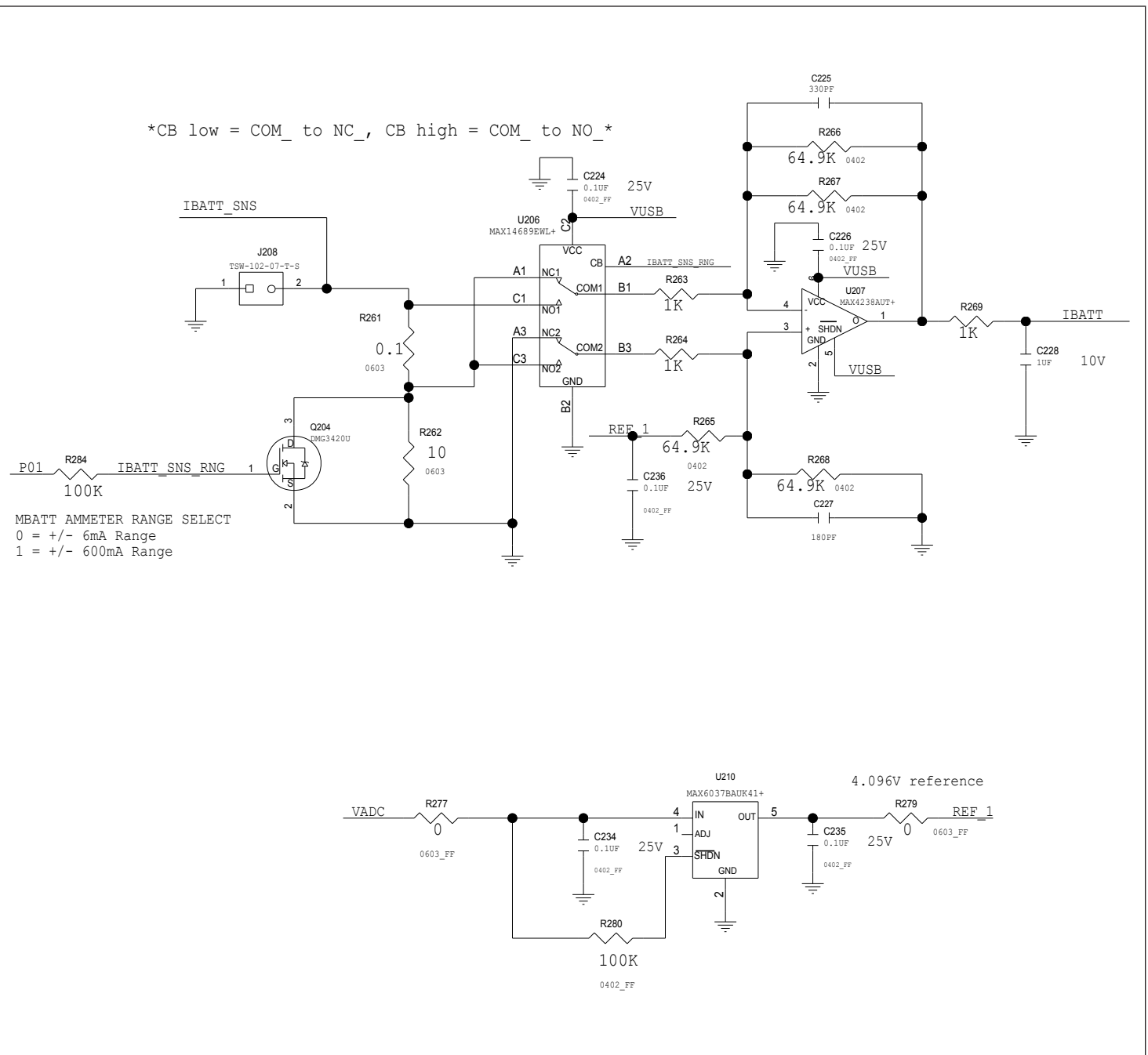
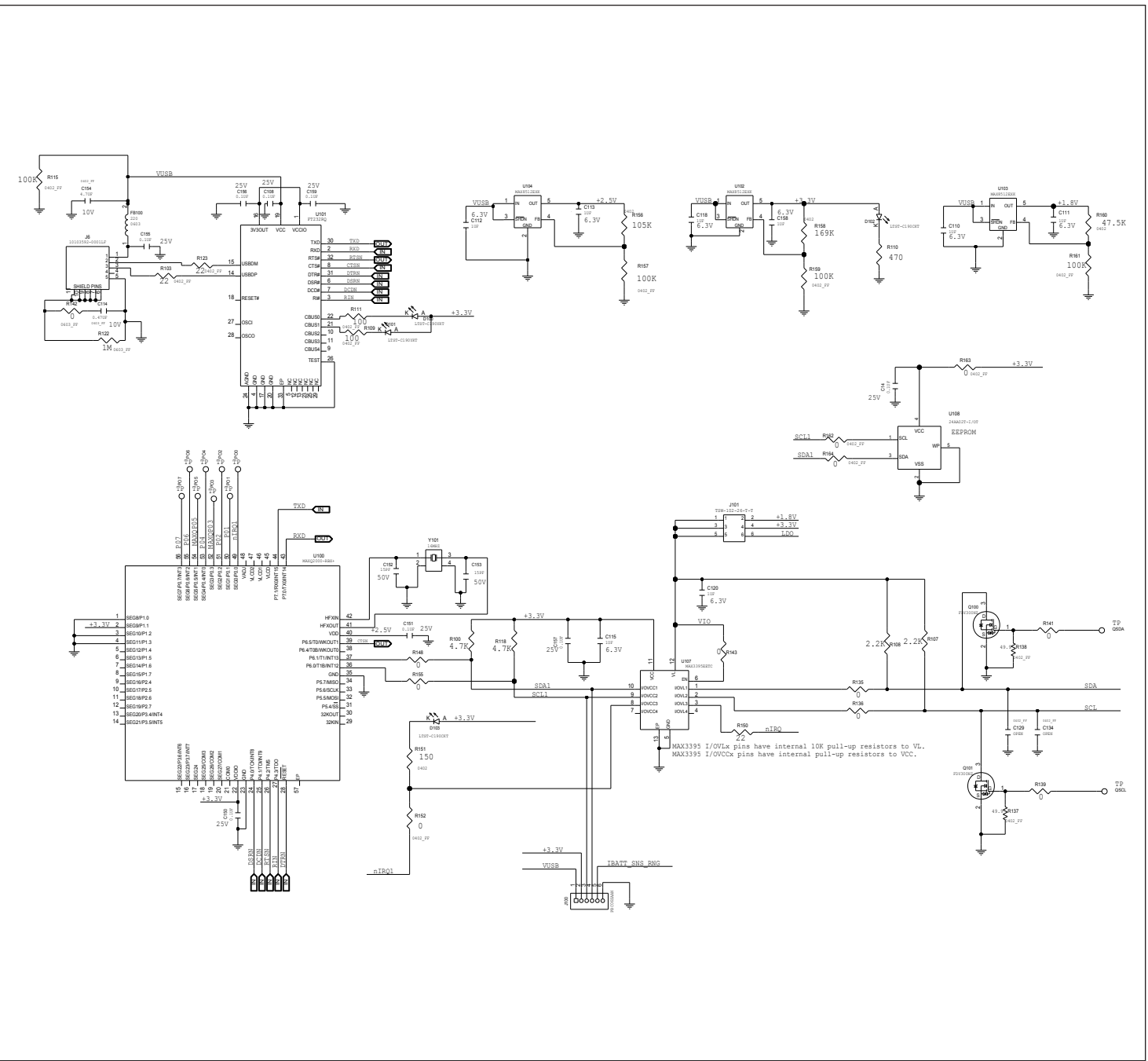
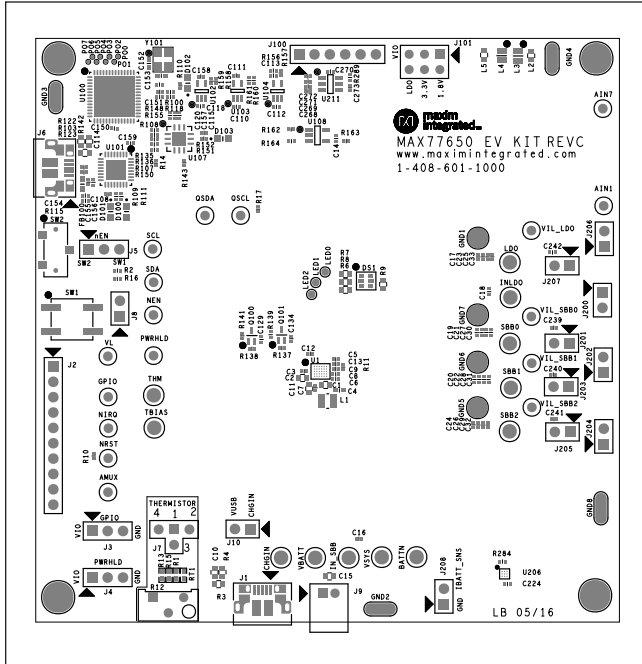

Figure 13. MAX77650/MAX77651 EV Kit Schematic (5 of 6)

MAX77650/MAX77651 EV Kit Schematic (continued)



MAX77650 EV Kit PCB Layouts



MAX77650 EV Kit Component Placement Guide—Top Silkscreen

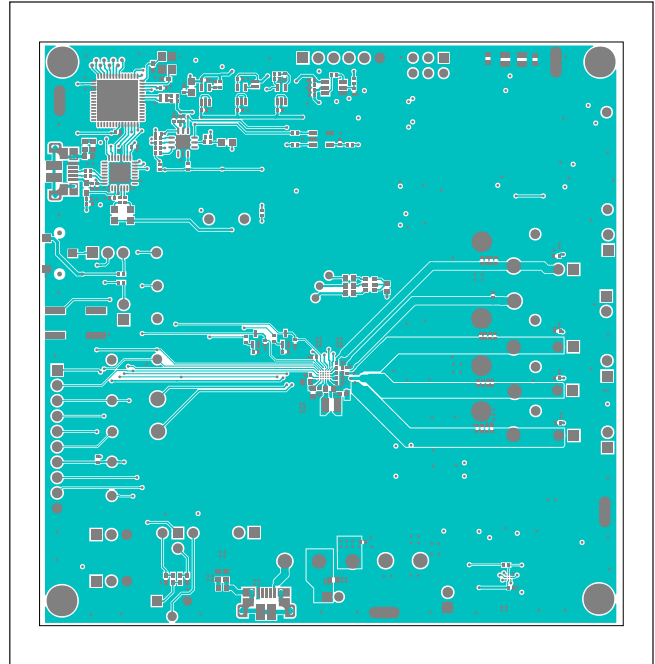

MAX77650 EV Kit PCB Layout—Top Layer

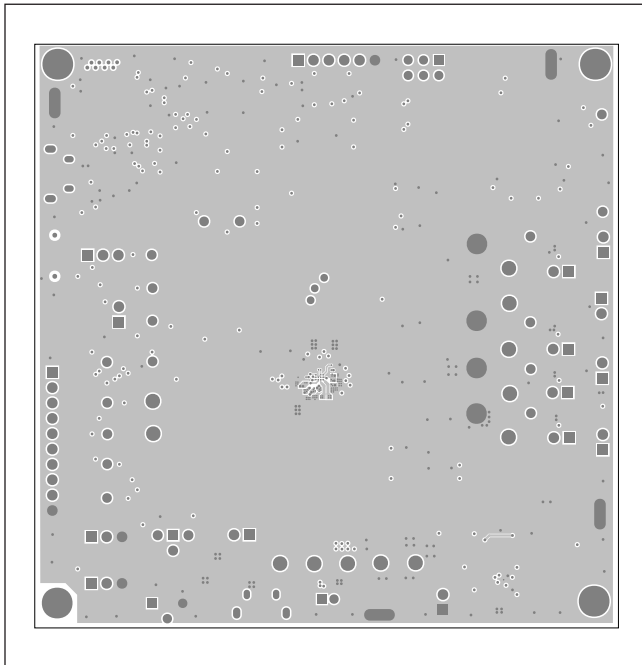

MAX77650 EV Kit PCB Layout—Internal Layer 2

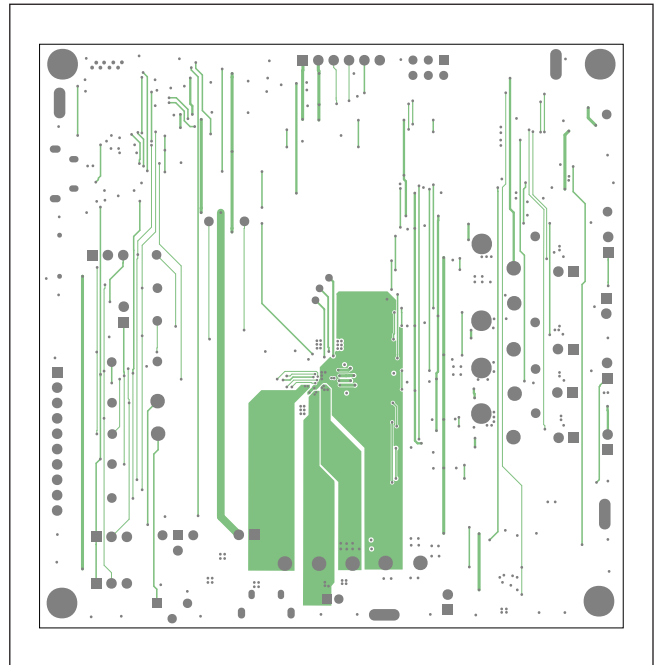

MAX77650 EV Kit PCB Layout—Internal Layer 3