



Chipsmall Limited consists of a professional team with an average of over 10 year of expertise in the distribution of electronic components. Based in Hongkong, we have already established firm and mutual-benefit business relationships with customers from,Europe,America and south Asia,supplying obsolete and hard-to-find components to meet their specific needs.

With the principle of "Quality Parts,Customers Priority,Honest Operation,and Considerate Service",our business mainly focus on the distribution of electronic components. Line cards we deal with include Microchip,ALPS,ROHM,Xilinx,Pulse,ON,Everlight and Freescale. Main products comprise IC,Modules,Potentiometer,IC Socket,Relay,Connector.Our parts cover such applications as commercial,industrial, and automotives areas.

We are looking forward to setting up business relationship with you and hope to provide you with the best service and solution. Let us make a better world for our industry!



## Contact us

Tel: +86-755-8981 8866 Fax: +86-755-8427 6832

Email & Skype: info@chipsmall.com Web: www.chipsmall.com

Address: A1208, Overseas Decoration Building, #122 Zhenhua RD., Futian, Shenzhen, China



# MAX79356 G3-PLC Sniffer Kit

## General Description

The MAX79356 G3-PLC sniffer dongle is a lightweight test and monitoring device for G3-PLC powerline communication networks. Accompanied by a user-friendly Windows® application, this portable sniffer enables capturing and analysis of data and command packets on powerline. A multifunction button allows the user to conveniently change the frequency band to CENELEC-A, CENELEC-B, FCC, or ARIB. The sniffer dongle is powered by a standard mini-USB port that can be connected to a power bank and used as a handheld test device in the field to check the signal phase and quality.

## Sniffer Kit Content

- One G3-PLC sniffer dongle with power cord
- One mini-USB cable

## Safety Notes

**WARNING:** Exercise extreme caution once connecting the device to the AC line. Ignoring the safety requirements can lead to shock, injury, and damage of the hardware.

Ordering Information appears at end of data sheet.

## Benefits and Features

- Low Power, Lightweight, and Portable, Operating on Cold Wire, DC, or 110–240VAC, 50Hz/60Hz
- Single FW Supports G3-PLC Standard CENELEC-A, CENELEC-B, FCC, and ARIB Frequency Bands as Well as Proprietary FCC-High Band
- Captures and Displays Packets on PC with a Windows Graphic Application
- Demonstrates Color Coded and Time-Stamped G3-PLC PHY and MAC Frames Including Beacons, Bootstrapping, Routing, Tonemap Response, ACK/NACK and Data Packets
- Configurable Decryption Keys Enable Real-Time Display of Decrypted Packets
- Channel Analyzer Function Graphically Visualizes the Channel Quality of Each OFDM Tone
- One-Click Report Generation for Statistical Analysis of Network Stability, Topology, and Communication Quality
- Programmable for Frequency Notching Support
- Integrated Firmware Update Utility for Future Upgrades
- A Must-Have Stand-Alone Tool in the Field for PLC Installers and Professionals That Significantly Reduces the Installation Troubleshooting by Providing Signal Quality and Phase Information and Enabling Site Surveys

## Sniffer Dongle Photo



Windows is a registered trademark and registered service mark of Microsoft Corporation.



---

# MAX79356 G3-PLC Sniffer Kit

## Detailed Description

Powered by Maxim's pioneer multiband G3-PLC chipset, the MAX79356 sniffer dongle works both as a sniffer device for monitoring and analyzing packets in powerline networks and as a handy portable test tool in the field to verify installations and diagnose the communication problems. The sniffer is preloaded with a universal band FW that supports G3-PLC standard CENELEC-A, CENELEC-B, FCC and ARIB bands as well as the proprietary FCC-high band (320kHz–487kHz). The band selection is done using a multifunction pushbutton on the dongle. A mini-USB cable (provided) is used to connect it to a PC. All necessary Windows drivers are installed automatically and it is identified as a COM port.

## Operation

The isolated power cord attached to the dongle is connected directly to AC, DC, or cold-wire line. If it is used as a sniffer, the mini-USB port is connected to a PC and sniffer application ([G3-PLC Sniffer Application](#) section) is launched. In case it is used as a stand-alone tester, the mini-USB should be connected to a standard 5VDC USB supply port such as a power bank (recommended).

## Changing Frequency Band

By pressing the multifunction pushbutton, the frequency band is switched to the next band and red LED blinks to the number associated with each band:

- 1) CENELEC-A (default)
- 2) FCC
- 3) ARIB
- 4) FCC-High
- 5) CENELEC-B

## G3-PLC Sniffer Application

The application communicates with the sniffer dongle through the installed COM port. [Figure 1](#) shows the capture of packets. The upper window shows the packets in tabular format with highlight of most frequently used information. The lower window shows the content of the selected packet with main fields dissected. The channel analyzer provides a measure of signal quality for different tones. [Figure 2](#) shows an example of channel quality in presence of a strong 350kHz interference. To display the content of encrypted packets, the decryption function is chosen and appropriate network keys are updated in the sniffer.

The application is also capable of generating graphical reports for a live sniffing session. The report displays the statistics of packet modulation. LQI distribution, Tonemap response analysis, percentage of usage of each subband, distribution of types of packets and number of discovered neighbors. [Figure 3](#) displays an example of the report.

## Sniffer as a Standalone Test Tool

Sniffer dongle can be powered through a 5VDC USB power bank (not included) and used as a test tool.

**Channel Quality:** Upon receiving a packet, one of the colored LEDs blinks to show the quality of the channel for that packet with green/yellow/red indicating good/medium/bad quality, respectively.

**Phase Difference:** To monitor the phase difference of the transmitter of the packet with the sniffer, press and hold the multifunction button for 2s. The phase difference is represented by color of 3 LEDs as shown in [Table 1](#) (see the polarity in schematics).

## Firmware Upgrade

If a new release of firmware is available, the integrated flash update utility in the **Program** menu of G3-PLC Sniffer GUI can be conveniently used to upgrade the firmware.

# MAX79356 G3-PLC Sniffer Kit

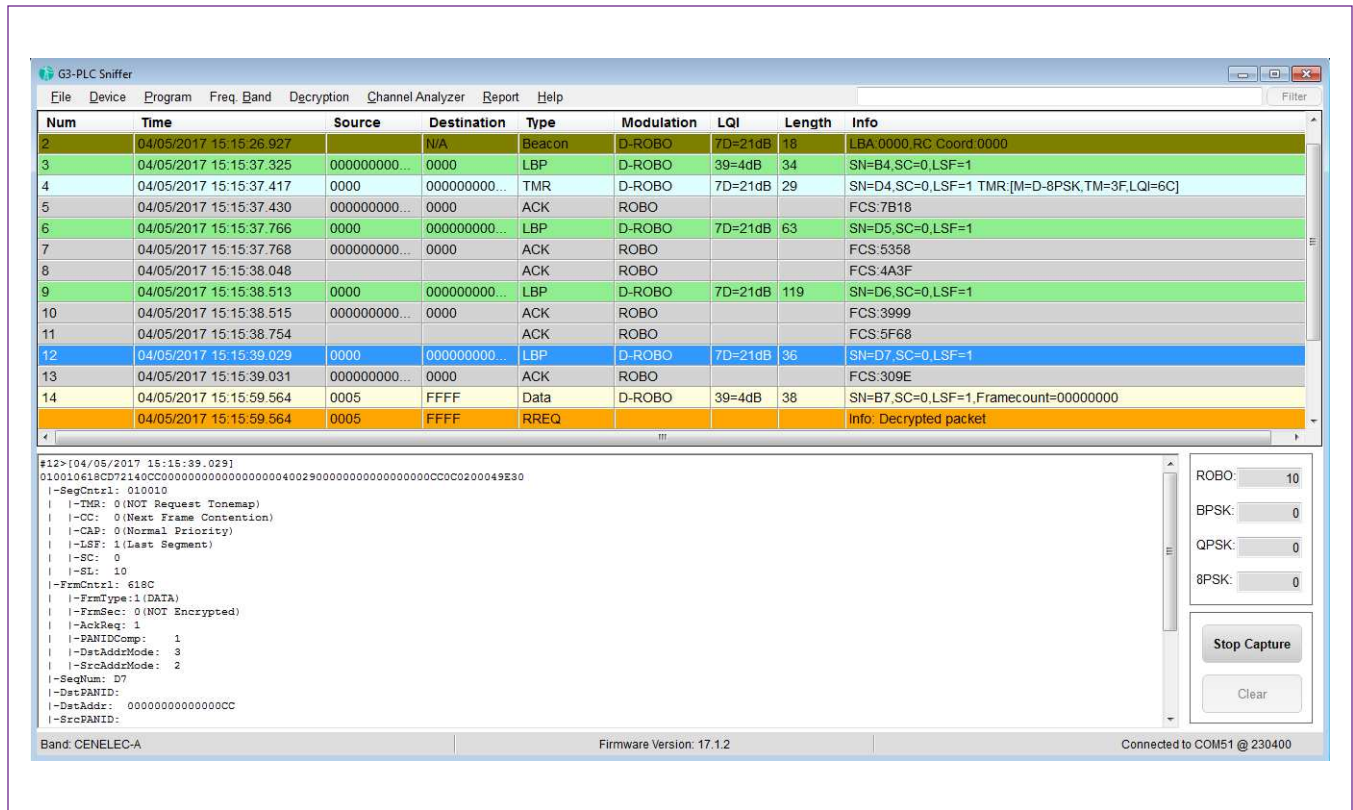

Figure 1. G3-PLC Sniffer GUI

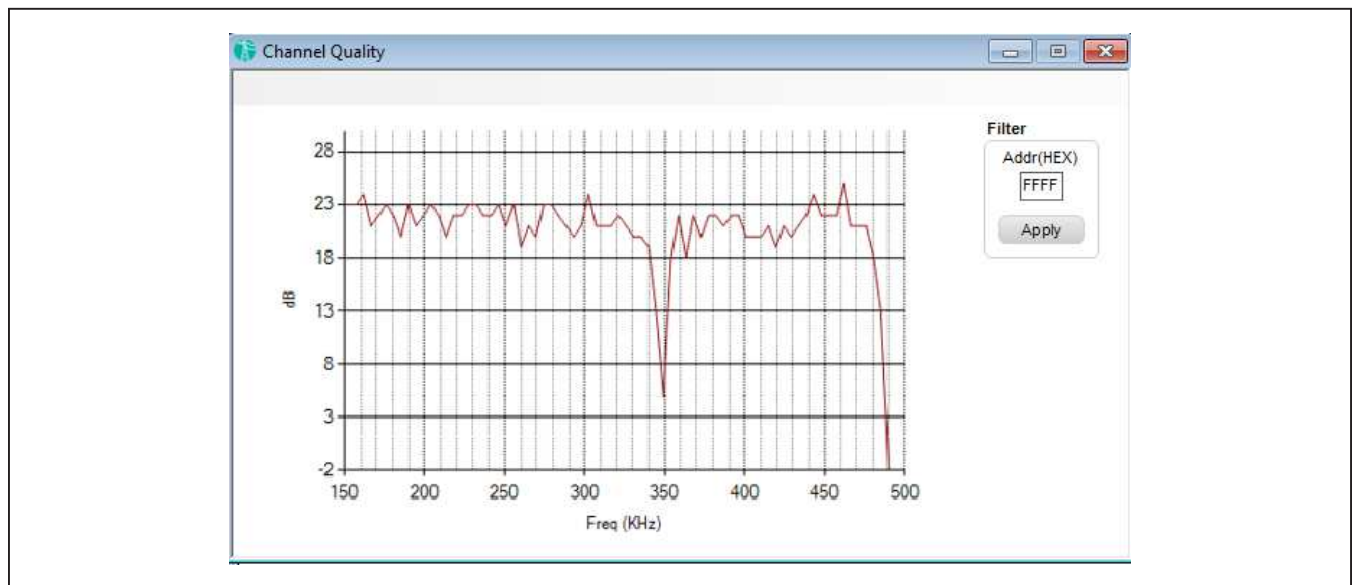

Figure 2. Channel Quality Analyzer Showing Strong 350kHz Interference

# MAX79356 G3-PLC Sniffer Kit

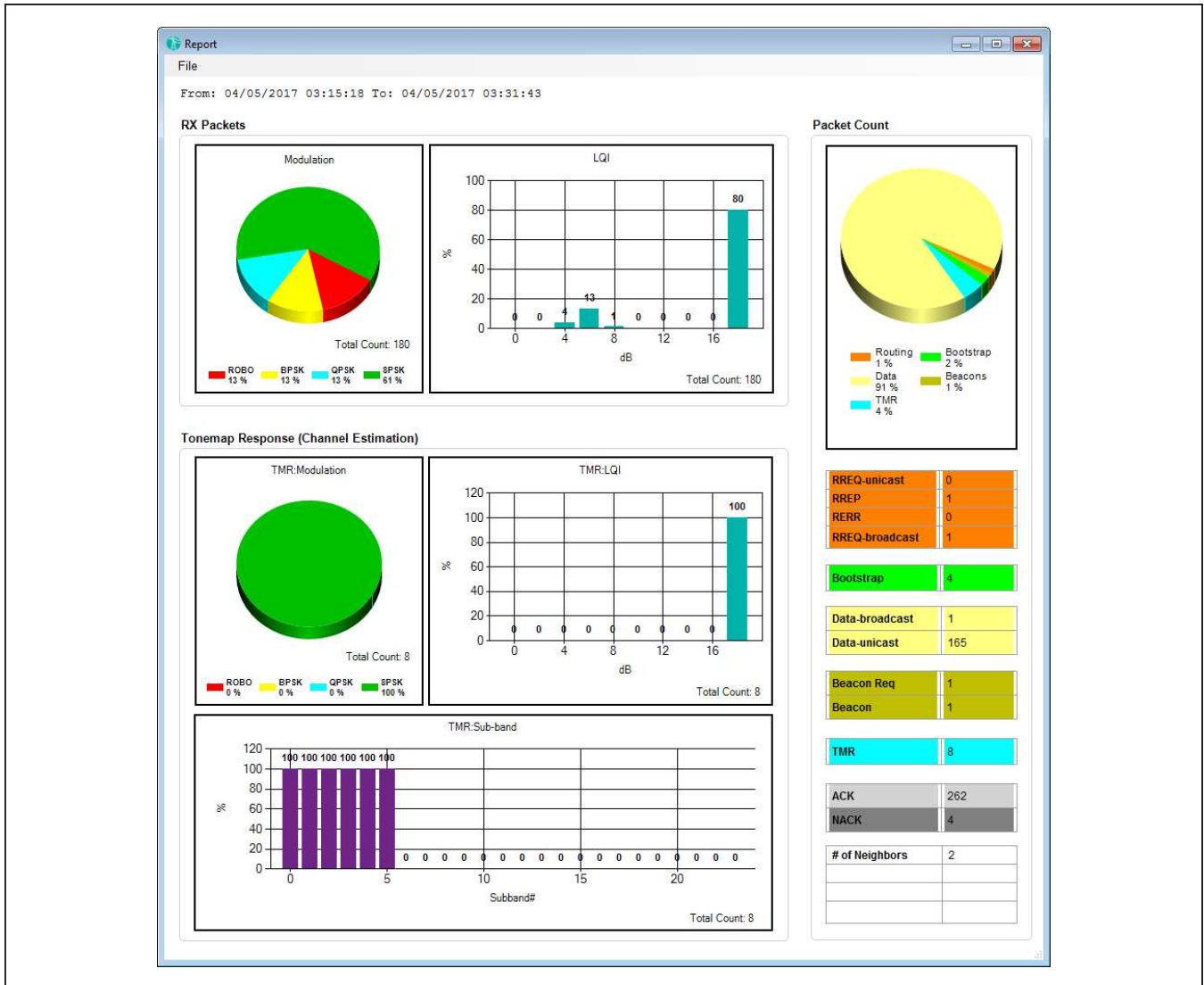

Figure 3. Report Generation Using the Live Packets

Table 1. LED Colors Representing the Phase Difference of Sniffer to the Transmitter

PHASE DIFFERENCE	LED COLORS		
	GREEN	YELLOW	RED
Same Phase	X		
60-Degree Lead		X	
120-Degree Lead			X
Opposite Phase		X	X
120-Degree Lag	X		X
60-Degree Lag	X	X	
Unavailable	X	X	X

---

## MAX79356 G3-PLC Sniffer Kit

### Ordering Information

PART	TYPE
MAX79356SNF#	G3-PLC sniffer kit

#Denotes RoHS compliance.

### General Specification

<b>Size</b>	3 x 1.25 x 1 (in)
<b>Weight</b>	4oz
<b>Power Supply</b>	5VDC, 250mW
<b>Port</b>	Mini-USB
<b>AC Connection</b>	110–240VAC, 50/60Hz
<b>Protocol</b>	G3-PLC
<b>Frequency Band</b>	CENELEC-A, CENELEC-B, FCC, ARIB, FCC-High
<b>Buttons</b>	One multifunction
<b>LEDs</b>	3

# MAX79356 G3-PLC Sniffer Kit

## MAX79356 SNIFFER EV Kit Bill of Materials

DESIGNATION	QTY	DESCRIPTION
C1	1	SMT (0805) 22µF 35V 20% capacitor
C2	1	SMT (0402) 4.7µF 10V 20% capacitor
C3, C6	2	SMT (0805) 1µF 25V 10% capacitors
C4, C8, C21, C22, C26, C27	6	SMT (0402) 0.1µF 25V 10% capacitors
C5, C11, C15, C17, C18, C24	6	SMT (0402) 1µF 25V 20% capacitors
C7	1	SMT (0805) 4.7µF 50V 10% capacitors
C9, C10	2	SMT (0402) 47pF 50V 5% capacitors
C12	1	SMT (0805) 10µF 35V 10% capacitors
C13, C14, C16, C19, C20, C25	6	SMT (0402) 0.1µF 35V 10% capacitors
C23	1	SMT (0402) 1nF 25V 5% capacitor
C29, C32	2	SMT (0402) 0.22µF 16V 10% capacitors
C30, C31	2	SMT (0402) 27pF 50V 5% capacitors
C33	1	SMT (0603) 0.68µF 50V 20% capacitor
C34	1	TH-LD POL 1µF 450V 5% capacitor
C35	1	SMT (1812) 1.5µF 100V 10% capacitor
D1	1	RECT; (SOD-123F) 30V 2A
D2, D3	2	SS; (SOT-23) PIV = 175V 0.6A
D4	1	LED; TH RED VF = 2V 0.02A
D5	1	LED; TH GRN VF=2.1V 0.02A
D7, D8	2	SS; 1N4148 DO-35 100V 0.2A
D10	1	LED; TH YEL VF = 2.1V 0.02A
D11	1	LED; BLU (0603) 3.2V 0.02A
F1	1	FUSE FAST SMT 1.25A 125V

DESIGNATION	QTY	DESCRIPTION
F2	1	FUSE SLOW (1206) 1A 63V
FB1–FB5	5	SMT (0603) FB 1500 .3A 25%
J1	1	Mini-USB B-TYPE SMT RA 5P
L1, L3	2	SMT (0805) 10µH 0.19A 10%
L2	1	SMT (1210) 1mH 0.1A 10%
Q1	1	NPN SOT-23 225mW .1A 30V
R5, R7	2	SMT (0402) 27Ω 0.063W 1% resistors
R9, R11, R20, R23, R27	5	SMT (0402) 10KΩ 0.063W 1% resistors
R12, R13	2	SMT (0603) 0Ω 0.25W 0% resistors
R14, R17, R22, R24, R33, R34	6	SMT (0603) 100Ω 0.125W 1% resistors
R15	1	SMT (0603) 4.99kΩ 0.125W 1% resistor
R21	1	SMT (0402) 1MΩ 0.063W 1% resistor
R26	1	SMT (1206) 110Ω 0.25W 1% resistor
R28, R30–R32	4	SMT (1206) 68kΩ 0.25W 5% resistors
R29	1	SMT (1206) 18kΩ 0.25W 5% resistor
SW1	1	TL1105 SPST TH RA 12V switch
TX1	1	VITEC XMR TH 10P (1.0 : 1.5)
U1	1	MAX16910CASA8 VREG
U2	1	FT234XD USB-UART DFN12
U3	1	TCMT1107 OPTOCOUPLER
U10	1	MAX79356ECM+ ZENO IC
Y1	1	CRYSTAL; TH 18PF 16MHZ
Z1–Z3	3	TVS SMC DO-214AB 10V 88A
Z4	1	TVS SMC PIV = 440V; IF = 2.1A

# MAX79356 G3-PLC Sniffer Kit

## MAX79356 SNIFFER EV Kit Schematics

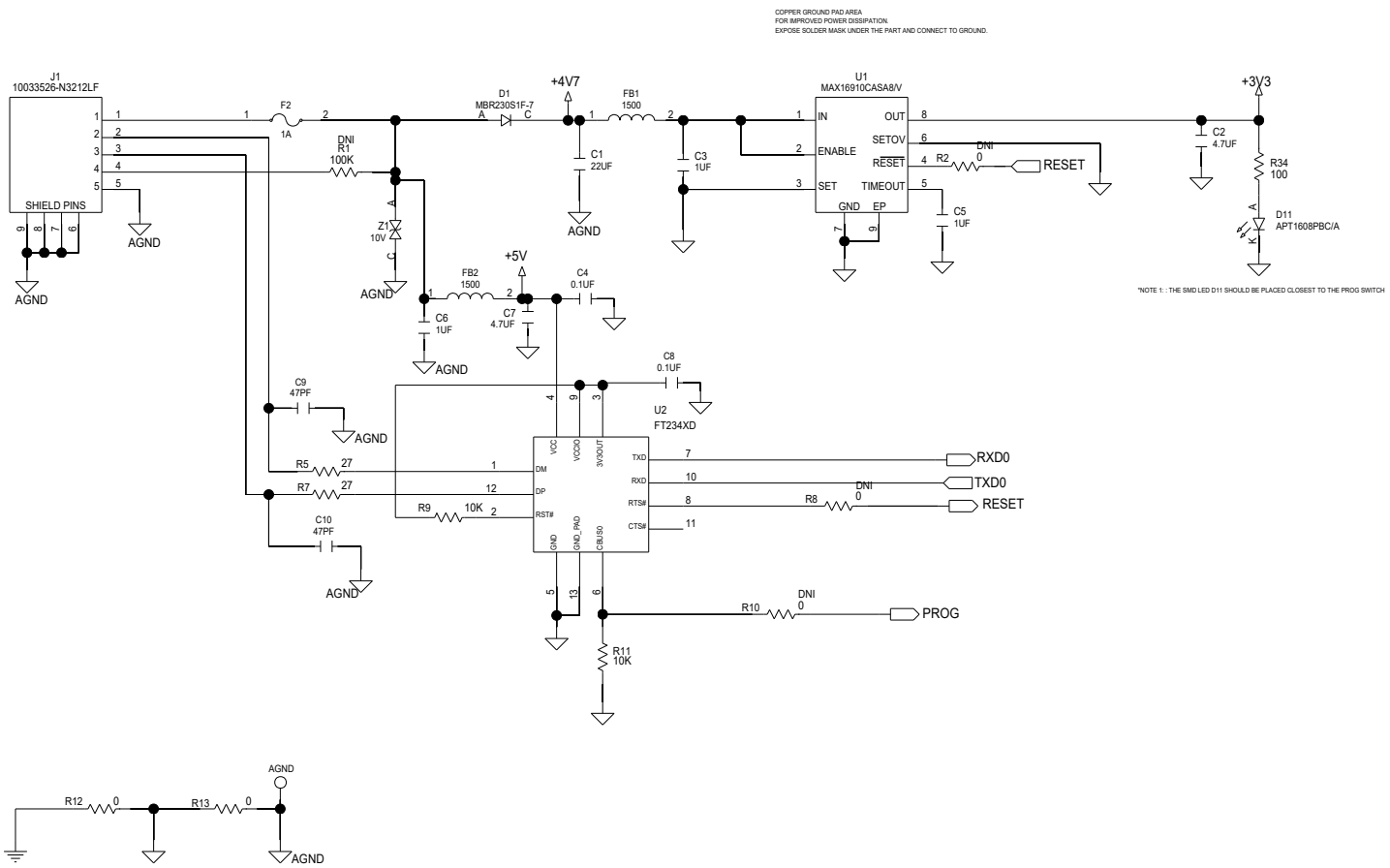



# MAX79356 G3-PLC Sniffer Kit

## MAX79356 SNIFFER EV Kit Schematics (continued)

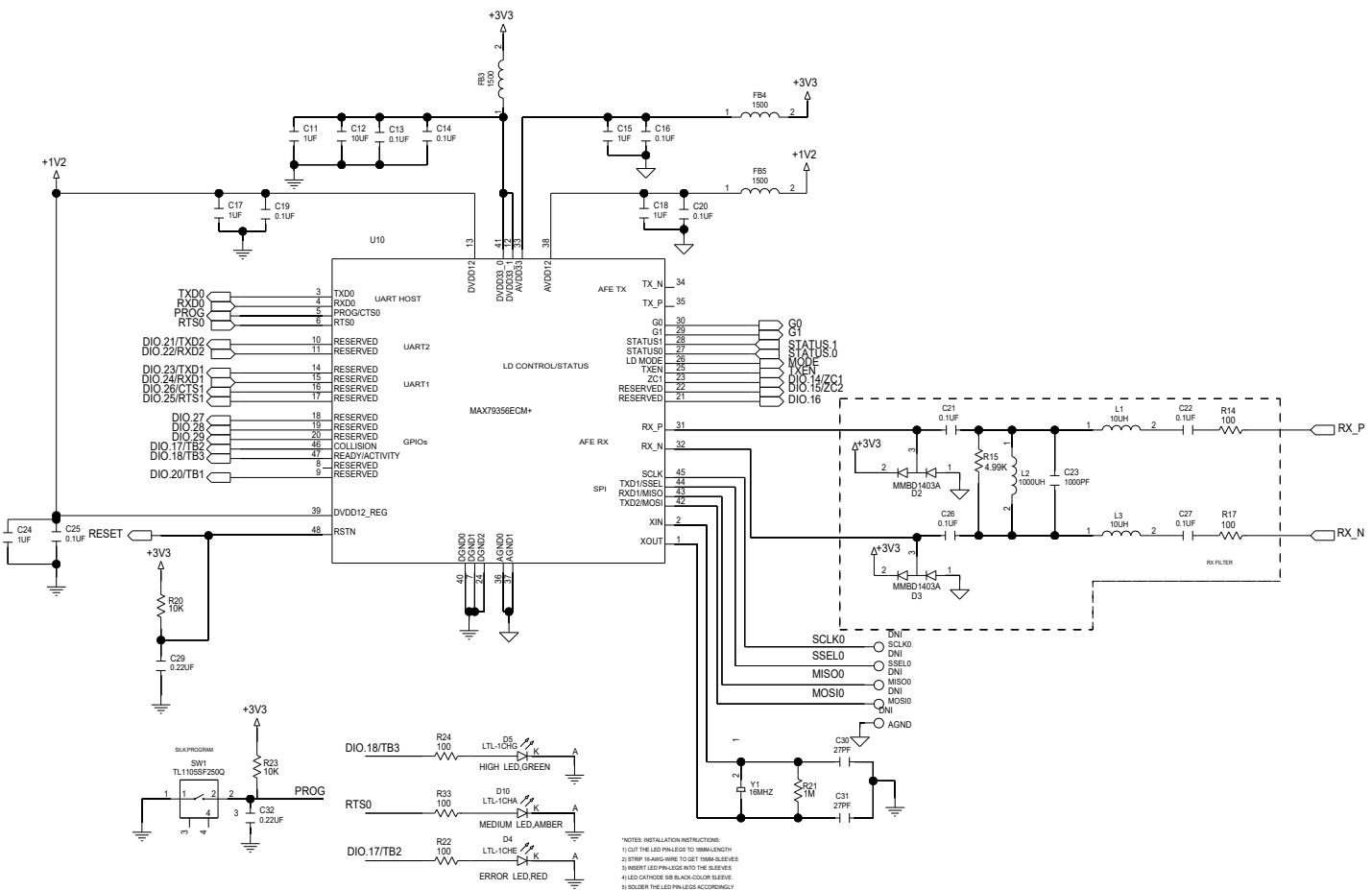

# MAX79356 G3-PLC Sniffer Kit

## MAX79356 SNIFFER EV Kit Schematics (continued)

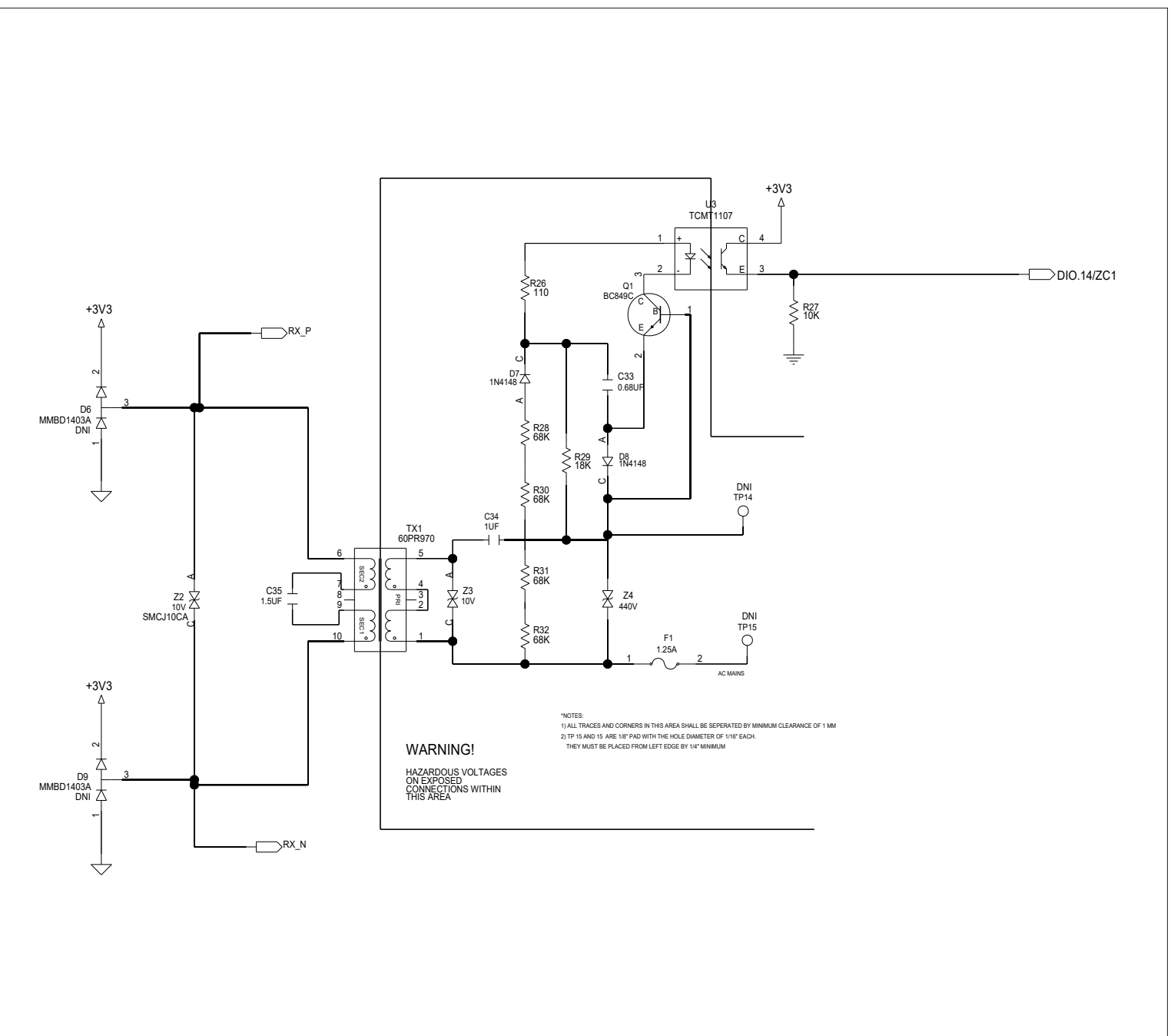

---

# MAX79356 G3-PLC Sniffer Kit

## Revision History

REVISION NUMBER	REVISION DATE	DESCRIPTION	PAGES CHANGED
0	4/17	Initial release	—
1	6/18	Updated <i>General Description, Benefits and Features, Detailed Description, Changing Frequency Band, Firmware Upgrade</i> , and <i>General Specification</i> for CENELEC-B band and notching support	1, 2, 5

For pricing, delivery, and ordering information, please contact Maxim Direct at 1-888-629-4642, or visit Maxim Integrated's website at [www.maximintegrated.com](http://www.maximintegrated.com).

*Maxim Integrated cannot assume responsibility for use of any circuitry other than circuitry entirely embodied in a Maxim Integrated product. No circuit patent licenses are implied. Maxim Integrated reserves the right to change the circuitry and specifications without notice at any time.*