

Chipsmall Limited consists of a professional team with an average of over 10 year of expertise in the distribution of electronic components. Based in Hongkong, we have already established firm and mutual-benefit business relationships with customers from,Europe,America and south Asia,supplying obsolete and hard-to-find components to meet their specific needs.

With the principle of “Quality Parts,Customers Priority,Honest Operation,and Considerate Service”,our business mainly focus on the distribution of electronic components. Line cards we deal with include Microchip,ALPS,ROHM,Xilinx,Pulse,ON,Everlight and Freescale. Main products comprise IC,Modules,Potentiometer,IC Socket,Relay,Connector.Our parts cover such applications as commercial,industrial, and automotives areas.

We are looking forward to setting up business relationship with you and hope to provide you with the best service and solution. Let us make a better world for our industry!



## Contact us

Tel: +86-755-8981 8866 Fax: +86-755-8427 6832

Email & Skype: info@chipsmall.com Web: www.chipsmall.com

Address: A1208, Overseas Decoration Building, #122 Zhenhua RD., Futian, Shenzhen, China



# MAX8655 Evaluation Kit

## General Description

The MAX8655 evaluation kit (EV kit) is a fully assembled and tested surface-mount PCB that contains a fixed-frequency, pulse-width modulated (PWM) step-down switching regulator. The MAX8655 EV kit provides a 1.2V output voltage from a 10.8V to 13.2V input source and delivers up to 20A output current. The MAX8655 IC features internal high-side and low-side power MOSFETs.

A reference input is provided for use with a high-accuracy external reference (REFIN) or for DDR and tracking applications. The MAX8655 EV kit operates at 600kHz. The MAX8655 IC has a programmable internal oscillator with frequency range from 200kHz to 1MHz. The MAX8655 can also be synchronized to an external clock by connecting the clock signal to FSYNC. A synchronization output (SYNCO) is provided to synchronize a second MAX8655 180° out-of-phase with the first by connecting SYNCO of the first MAX8655 to FSYNC of the second.

## Features

- ◆ 10.8V to 13.2V Input-Voltage Range
- ◆ 20A Maximum Output Current (Additional Airflow or Heat Sink May be Required Above 13A of Output Current)
- ◆ Adjustable Output from 0.7V to 5.5V
- ◆ Internal High-Side and Low-Side Power MOSFETs
- ◆ 200kHz to 1MHz Adjustable Switching Frequency and SYNC Input
- ◆ SYNCO Synchronizes 2nd Regulator 180° Out-of-Phase
- ◆ Monotonic Startup Provides Safe Starting Into a Pre-Biased Output
- ◆ Enable Input and Power-OK Signals
- ◆ Low-Profile Components
- ◆ Lead-Free and RoHS Compliant
- ◆ Fully Assembled and Tested

## Ordering Information

PART	TYPE
MAX8655EVKIT+	EV Kit

+ Denotes lead-free and RoHS compliant.

## Component Lists

### MAX8655 Circuit

DESIGNATION	QTY	DESCRIPTION
C1	1	Not installed, ceramic capacitor (1210)
C2, C3, C4	3	10 $\mu$ F, 25V X5R ceramic capacitors (1210) Murata GRM32DR61E106KA12B
C6	1	2.2 $\mu$ F $\pm$ 20%, 10V X5R ceramic capacitor (0603) Murata GRM188R61A225KE34
C6A1, C7A, C8A	0	Not installed, ceramic capacitors
C7	1	0.22 $\mu$ F, 10V ceramic capacitor (0603) Murata GRM188R71A224KA01
C8	1	0.22 $\mu$ F, 25V X7R ceramic capacitor (0603) Murata GRM188R71E224KA88D
C9–C12	4	100 $\mu$ F, 6.3V X5R ceramic capacitors (1210) Murata GRM32ER60J107ME20

DESIGNATION	QTY	DESCRIPTION
C13, C17	2	0.47 $\mu$ F, 10V X5R ceramic capacitors (0402) Murata GRM155R61A474KE15
C14	1	1 $\mu$ F $\pm$ 20%, 10V X5R ceramic capacitor (0603) Murata GRM188R61A105KA61
C15	1	1000pF $\pm$ 10%, 50V ceramic capacitor (0603) Murata GRM188R71H102KA01
C16	1	0.022 $\mu$ F, 50V X5R ceramic capacitor (0402) Murata GRM155R71H223KA12D
C18	1	100pF, 50V X7R ceramic capacitor (0402) Murata GRM1555C1H101JZ01
C19	1	470pF, 50V ceramic capacitor (0402) Murata GRM155R71H471KA01
C20, R1	0	Not installed, ceramic capacitors (0402)

# MAX8655 Evaluation Kit

## Component Lists (continued)

### MAX8655 Circuit

DESIGNATION	QTY	DESCRIPTION
D1	1	SMD Schottky diode Central Semi CM0SH-3 BK
JP1, JP3, JP9	3	Terminal blocks, 5mm On Shore EDZ500/2DS Digi-Key ED1975-ND
JP2, JP5, JP6, JP7	4	2-pin headers, 0.1in
JP4	1	4-pin header, 0.1in
JP8, JP10	2	3-pin headers, 0.1in
L1	1	0.56 $\mu$ H, 1.8m $\Omega$ , 27.5A inductor (11.5mm x 10.3mm x 4mm) Vishay IHLP-4040DZ-ERR56M01
R2, R17	2	0 $\Omega$ $\pm$ 1% resistors (0402), lead-free
R3	1	3.3 $\Omega$ $\pm$ 1% resistor (1206), lead-free
R4	1	681 $\Omega$ $\pm$ 1% resistor (0402), lead-free

DESIGNATION	QTY	DESCRIPTION
R5, R9, R14	0	Not installed, resistors (0402)
R6	1	357 $\Omega$ $\pm$ 1% resistor (0402), lead-free
R7	1	40.2k $\Omega$ $\pm$ 1% resistor (0402), lead-free
R8	1	2.87k $\Omega$ $\pm$ 1% resistor (0402), lead-free
R10	1	4.02k $\Omega$ $\pm$ 1% resistor (0402), lead-free
R11	1	80.6k $\Omega$ $\pm$ 1% resistor (0402), lead-free
R12, R35	2	100k $\Omega$ $\pm$ 1% resistors (0402), lead-free
R13	1	56.2k $\Omega$ $\pm$ 1% resistor (0402), lead-free
R15	1	41.2k $\Omega$ $\pm$ 1% resistor (0402), lead-free
R16	1	51.1k $\Omega$ $\pm$ 1% resistor (0402), lead-free
R18	1	10 $\Omega$ $\pm$ 1% resistor (0402), lead-free
U1	1	Synchronous-PWM buck regulator (56 TQFN-EP*) Maxim MAX8655ETN+

\*EP = Exposed pad.

### MAX8688 Circuit—Not Installed

DESIGNATION	QTY	DESCRIPTION
C201, C202, C203, C205, C206, C207	0	100nF $\pm$ 10%, 50V X7R ceramic capacitors (0603), open Murata GRM188R71H104KA93
C204	0	1 $\mu$ F $\pm$ 10%, 10V X5R ceramic capacitor (0603), open Murata GRM188R61A105KA61
C208	0	2.2 $\mu$ F $\pm$ 10%, 10V X5R ceramic capacitor (0603), open Murata GRM188R61A225KE34
C209	0	Ceramic capacitor, open
C210	0	0.47 $\mu$ F $\pm$ 10%, 10V X5R ceramic capacitor (0603), open Murata GRM188R61A474KA61
JP201	0	4-pin header, open
JP202, JP203, JP204	0	3-pin headers, open
R19	0	100k $\Omega$ $\pm$ 1% resistor, open (0402)

DESIGNATION	QTY	DESCRIPTION
R201, R204, R206, R208, R209, R214	0	Resistors, open (0402)
R202	0	0 $\Omega$ resistor (0603)
R203	0	1k $\Omega$ $\pm$ 1% resistor (0402), open
R205, R207, R210	0	33k $\Omega$ $\pm$ 1% resistors (0402), open
R211	0	300 $\Omega$ $\pm$ 5% resistor (0603), open
R212	0	499 $\Omega$ $\pm$ 1% resistor (0603)
R213	0	100k $\Omega$ $\pm$ 1% resistor (0603), open
R215	0	10k $\Omega$ $\pm$ 1% resistor (0402), open
R216, R217	0	100 $\Omega$ $\pm$ 1% resistors (0402), open
U201	0	Digital power-supply controller, open Maxim MAX8688+
U202	0	AT24C01A-10TSU-1.8, open
U203	0	Voltage regulator (SOT-223) NS LM317EMP

## Component Suppliers

SUPPLIER	PHONE	WEBSITE
Central Semiconductor	631-435-1110	www.centralsemi.com
Digi-Key Corp.	800-344-4539	www.digikey.com
Murata Electronics North America, Inc.	770-436-1300	www.murata-northamerica.com
Vishay	402-563-6866	www.vishay.com

**Note:** Indicate that you are using the MAX8655 when contacting these component suppliers.

# MAX8655 Evaluation Kit

## Quick Start

### Recommended Equipment

Before beginning, the following equipment is needed:

- MAX8655 EV kit
- Up to 12V at 5A adjustable DC power supply
- Digital multimeters (DMM)
- Up to 20A load
- Ammeter (optional)

### Procedure

The MAX8655 EV kit is fully assembled and tested. Follow the steps below to verify board operation. **Caution: Do not turn on the power supply until all connections are completed.**

- 1) Set the power-supply output to 12V. Turn off the power supply.
- 2) Verify that there is a shunt across the pins of jumper JP2 (SCOMP and GND).
- 3) Verify that there is a shunt across pins 2-3 of jumper JP8 (MODE and GND).
- 4) Verify that there is a shunt across jumper JP5 (AVL and REFIN).
- 5) Connect the positive lead of the power supply to the VIN pad of the JP1 terminal block and connect the negative lead of the power supply to the GND pad of the JP9 terminal on the EV kit.
- 6) Connect the positive lead of the DMM to the VOUT pad and connect the negative lead of the DMM to the GND pad on the EV kit.
- 7) Turn on the power supply.
- 8) Verify that the output voltage is 1.2V at the output (between JP3 and JP9 terminals) of the MAX8655\_MAX8688 EV board.
- 9) Connect the load between VOUT and GND.
- 10) Verify that the voltage at VOUT is approximately 1.2V.

### Detailed Description of Hardware

The MAX8655 EV kit operates from a 10.8V to 13.2V input and generates an output voltage of 1.2V at loads up to 20A. The MAX8655 EV kit features a circuit of a step-down regulator operating on a PWM, peak current-mode control scheme. Integrated power MOSFETs provide a small footprint, ease of layout, and reduced EMI.

The EV kit features an FSYNC pad to allow the converter to synchronize with an external clock. See the *Evaluating Other Switching Frequencies and External Clock Synchronization (FSYNC and SYNCO)* section.

### Evaluating Other Output Voltages

The output voltage of the MAX8655 can be adjusted from 0.7V (min) to 5.5V (max). To set the output voltage for the MAX8655, connect FB to the center of an external resistor-divider from the output to GND (R8 and R10 of the MAX8655 EV kit). Select R10 between 5kΩ and 24kΩ, and then calculate R8 with the following equation:

$$R8 = R10 \times \left( \frac{V_{OUT}}{V_{FB}} - 1 \right)$$

where  $V_{FB} = 0.7V$  or  $V_{REFIN}$ . Resistors R8 and R10 should be placed as close as possible to the IC.

Refer to the MAX8655 IC data sheet to calculate other associated components.

### Evaluating Other Switching Frequencies and External Clock Synchronization (FSYNC and SYNCO)

The MAX8655 has an adjustable internal oscillator that can be set to any frequency from 200kHz to 1MHz. To set the switching frequency, connect a resistor (RFSYNC) from FSYNC to GND. RFSYNC is calculated as:

$$R_{FSYNC} = \frac{30600}{f_s} - 9.914$$

where  $f_s$  is the desired switching frequency in kilohertz.

The MAX8655 can also be synchronized to an external clock by connecting the clock signal to FSYNC. A synchronization output (SYNCO) generates a clock signal that is 180° out-of-phase, which allows for another MAX8655 to be synchronized 180° out-of-phase with the first, by connecting SYNCO of the first MAX8655 to FSYNC of the second to reduce the input ripple current.

### Undervoltage Lockout (UVLO)

When  $V_{AVL}$  drops below 4.03V, the MAX8655 assumes that the supply voltage is too low to make valid decisions, so the undervoltage-lockout (UVLO) circuitry inhibits switching and turns off both internal power MOSFETs. When  $V_{AVL}$  rises above 4.15V, the regulator enters the startup sequence and then resumes normal operation.

# MAX8655 Evaluation Kit

## Power-OK (POK)

POK is an open-drain output on the MAX8655 that monitors the output voltage. When the output is above 92% of its nominal regulation voltage, POK is high impedance. When the output drops below 89% of its nominal regulation voltage, POK is internally pulled low. POK is also internally pulled low when the MAX8655 is shut down or in a fault condition.

## Soft-Start and REFIN

The internal soft-start circuitry gradually ramps up the reference voltage to control the rate of rise of the output voltage and reduce input surge currents during startup. The soft-start period is determined by the value of the capacitor from SS to GND. The soft-start time is approximately given by:

$$t_{SS} = (30.4\text{ms}/\mu\text{F}) \times C_{SS}$$

where  $t_{SS}$  = soft-start time in seconds and  $C_{SS}$  is the value of the capacitor at the SS pin.

The MAX8655 also features monotonic output-voltage rise, which allows the MAX8655 to safely start up into a prebiased output without pulling the output voltage down.

The MAX8655 has a reference input (REFIN). When an external reference up to 1.5V is connected to REFIN, the feedback regulation voltage is equal to the voltage applied to REFIN.

Connect REFIN to AVL to use the internal 0.7V reference (jumper JP5).

## Current Limit

The MAX8655 uses both foldback and peak current limiting.

## Peak Current Limit

The peak current-limit threshold ( $V_{TH}$ ) is set by a resistor connected from ILIM1 to GND ( $R_{ILIM1}$ ).  $V_{TH}$  corresponds to the peak voltage across the sensing element (inductor or current-sense resistor).  $R_{ILIM1}$  is calculated as follows:

$$R_{ILIM1} = \frac{7.5 \times V_{TH}}{10\mu\text{A}}$$

The peak current limit is used to sense the inductor current, and is more accurate than the valley current limit since it does not depend upon the on-resistance of the low-side MOSFET.

## Valley Current Limit

The MAX8655 has an adjustable valley current limit, configurable for foldback with automatic recovery, or constant current limit with latch-up. The valley current is sensed across the on-resistance of the low-side MOSFET. When the latch-off mode is used, connect MODE to AVL and set the current-limit threshold with one resistor from ILIM2 to GND. To use foldback current limit with auto recovery, connect MODE to GND and connect a resistor from ILIM2 to the output (R11), and another resistor from ILIM2 to GND (R16). Cycle EN or input power to reset the current-limit latch. For further information refer to the *Setting the Current Limit* section in the MAX8655 IC data sheet.

## Overvoltage Protection (OVP)

The MAX8655 provides output overvoltage protection (OVP), which is set independent of the output regulation voltage with a resistor voltage-divider connected between the output and GND (R9 and R14 of Figure 1a). When the voltage at OVP exceeds the OVP threshold, the regulator stops switching and latches on the low-side power MOSFET. Cycle EN or the power applied to AVL to clear the latch.

Select R14 between 5k $\Omega$  and 24k $\Omega$ , then calculate R9 with the following equation:

$$R9 = R14 \times \left( \frac{V_{OUT}}{V_{OVP}} - 1 \right)$$

where  $V_{OVP} = 1.15 \times V_{FB}$  and  $V_{OUT}$  = voltage at which OVP protection should set in.

## Evaluating the MAX8688

The MAX8688 is a fully digital power-supply manager that can be tested in conjunction with the MAX8655. Samples of the MAX8688 IC can be ordered from Maxim. To test the MAX8688, populate it with its circuitry, as shown in the schematic or in the component list. Populate R215 with 10k $\Omega$  to connect pin 3 of JP201 (RST) and pin 1 of JP204 (3.3V). Also, remove the shunt on pins 1-2 of JP5. For further information, refer to the MAX8688 IC data sheet.

# MAX8655 Evaluation Kit

## Typical Operating Characteristic

Evaluates: MAX8655/MAX8688

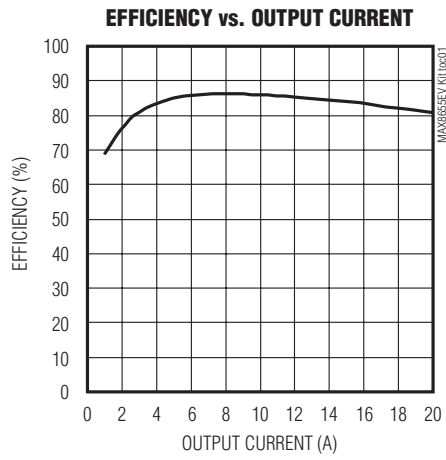

# Evaluates: MAX8655/MAX8688

## MAX8655 Evaluation Kit

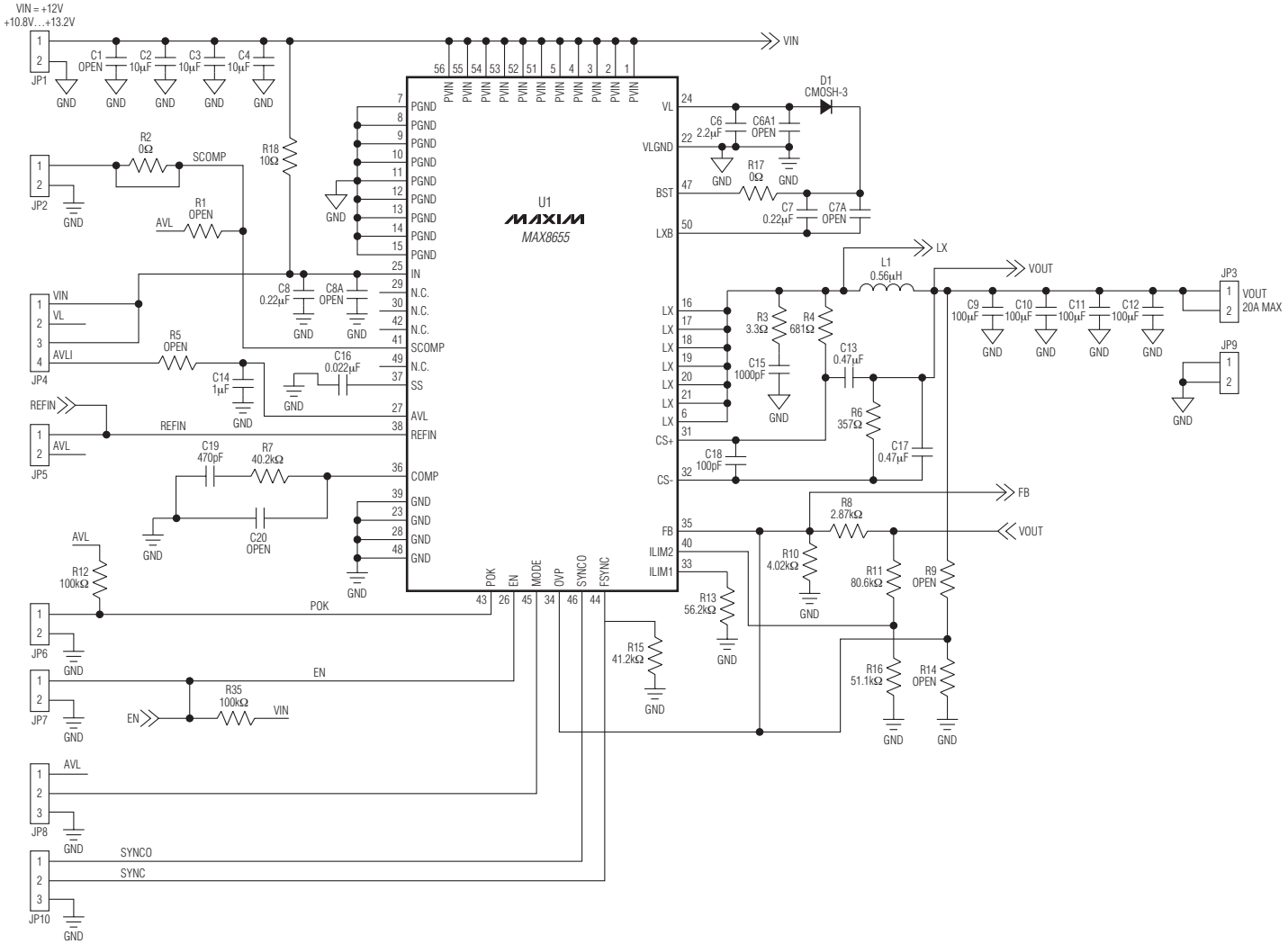

Figure 1a. MAX8655 EV Kit Schematic (Sheet 1 of 2)





# MAX8655 Evaluation Kit

Evaluates: MAX8655/MAX8688

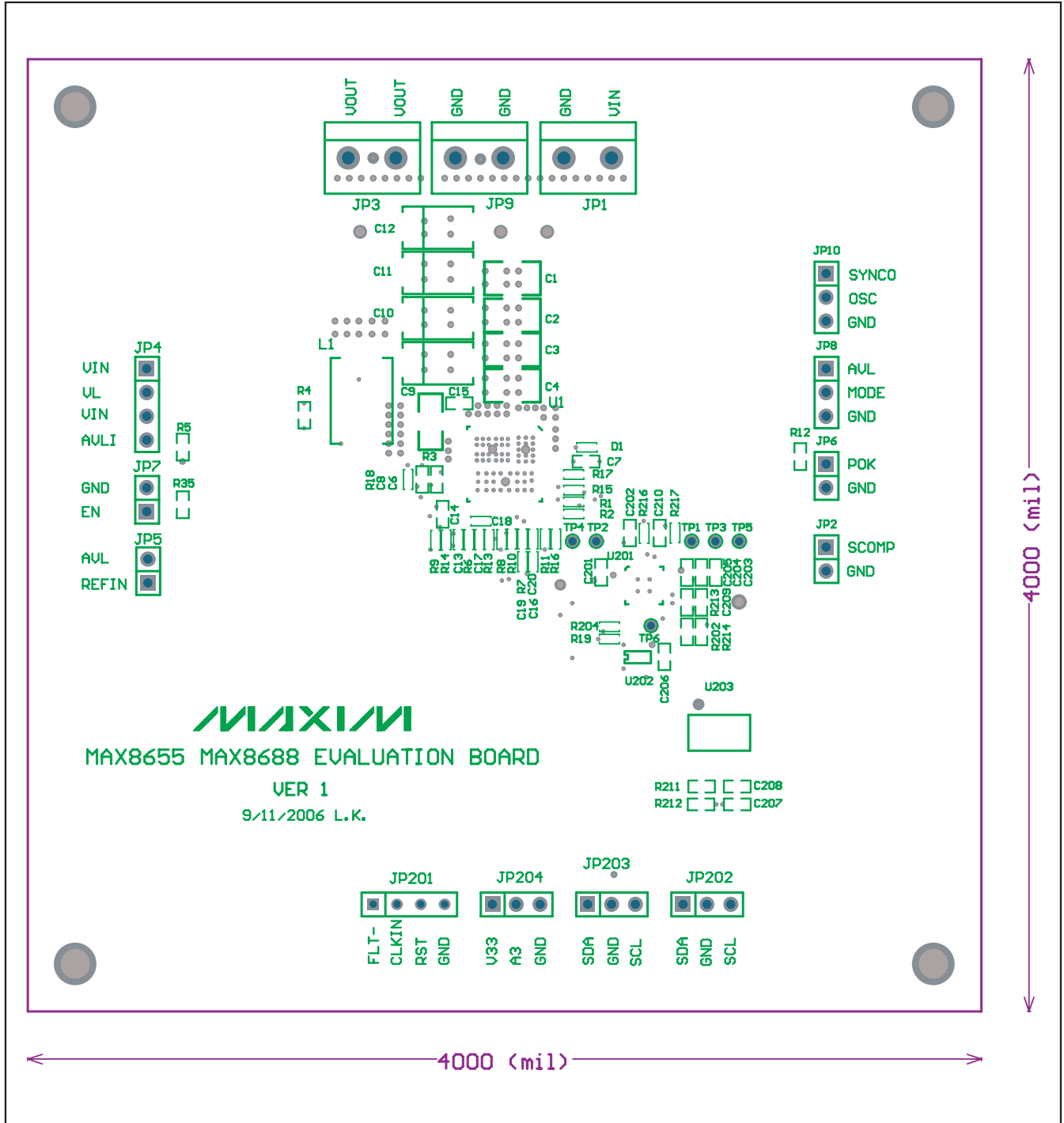

Figure 2. MAX8655 EV Kit Component Placement Guide—Component Side

# MAX8655 Evaluation Kit

Evaluates: **MAX8655/MAX8688**

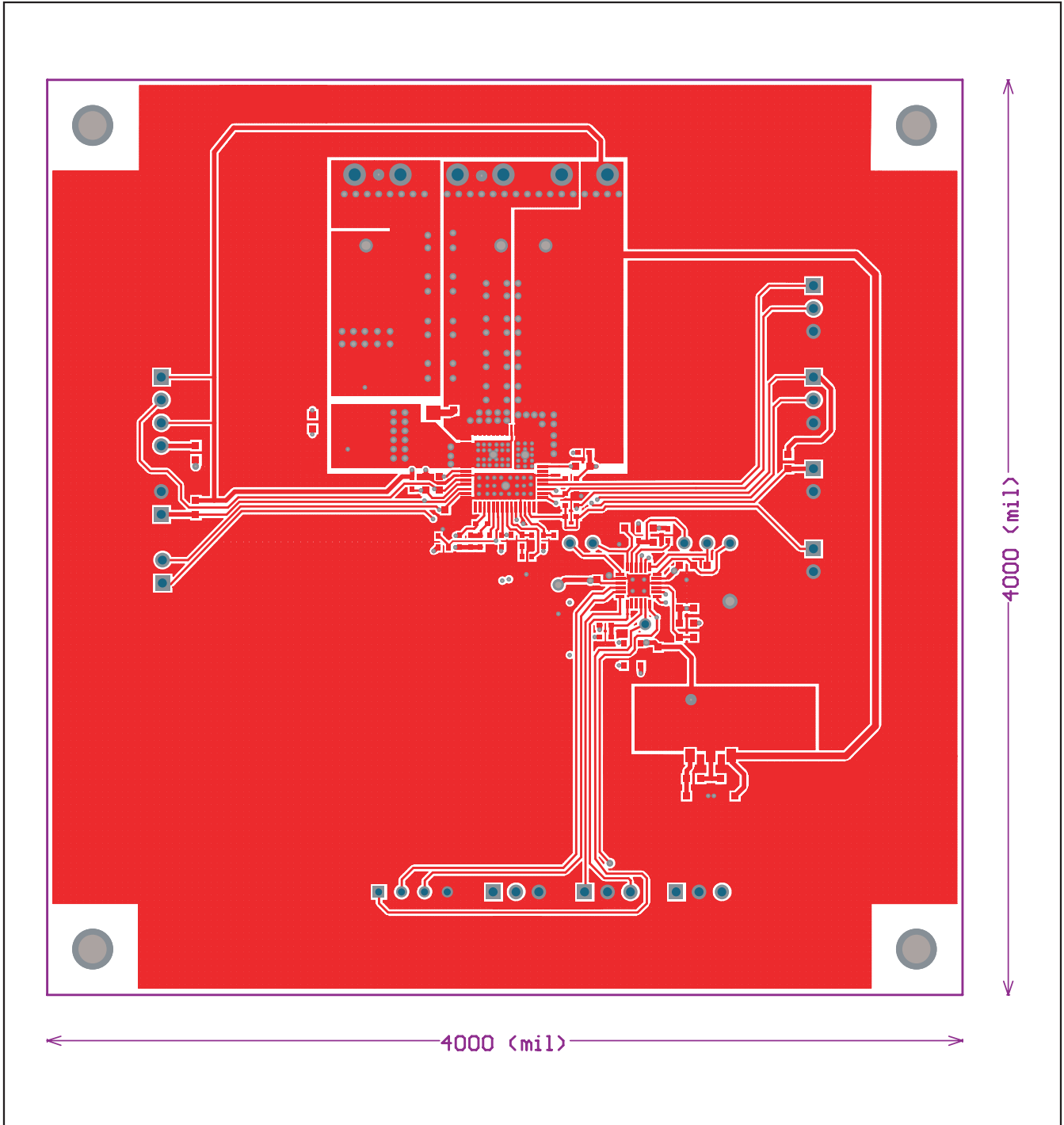

Figure 3. MAX8655 EV Kit PCB Layout—Component Side

# MAX8655 Evaluation Kit

Evaluates: MAX8655/MAX8688

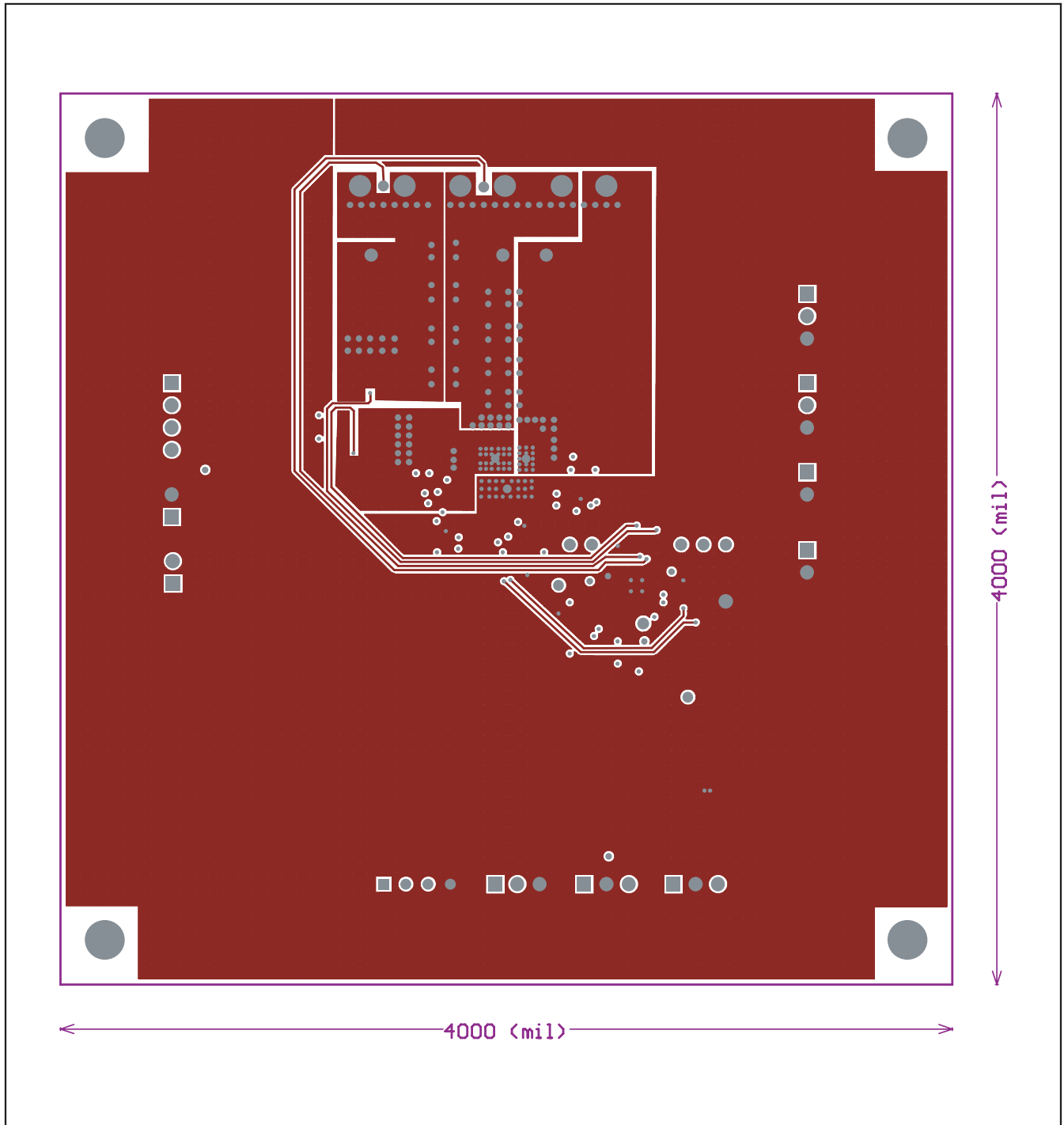

Figure 4. MAX8655 EV Kit PCB Layout—Inner Layer 1

# MAX8655 Evaluation Kit

Evaluates: **MAX8655/MAX8688**

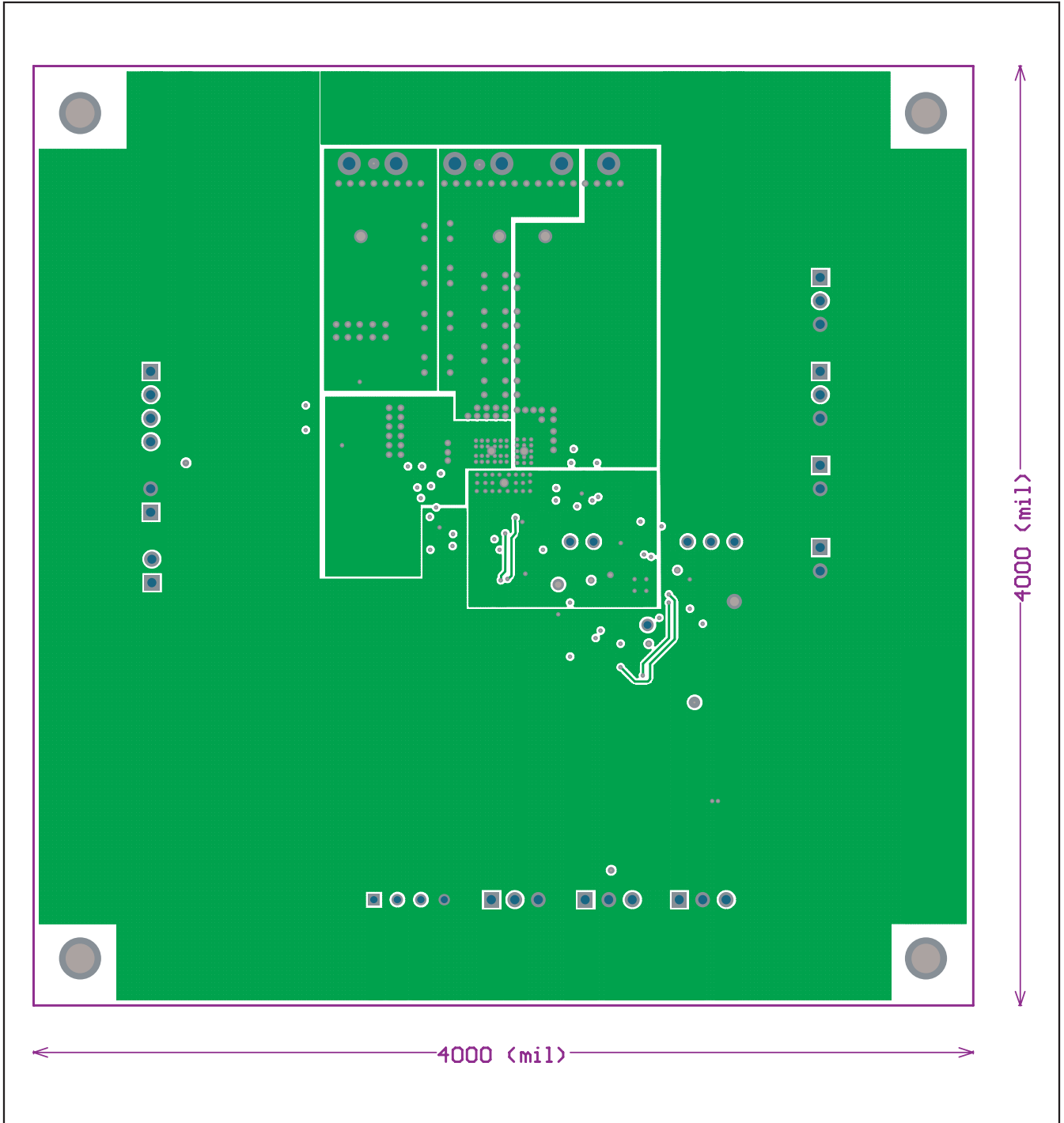

Figure 5. MAX8655 EV Kit PCB Layout—Inner Layer 2

# MAX8655 Evaluation Kit

Evaluates: MAX8655/MAX8688

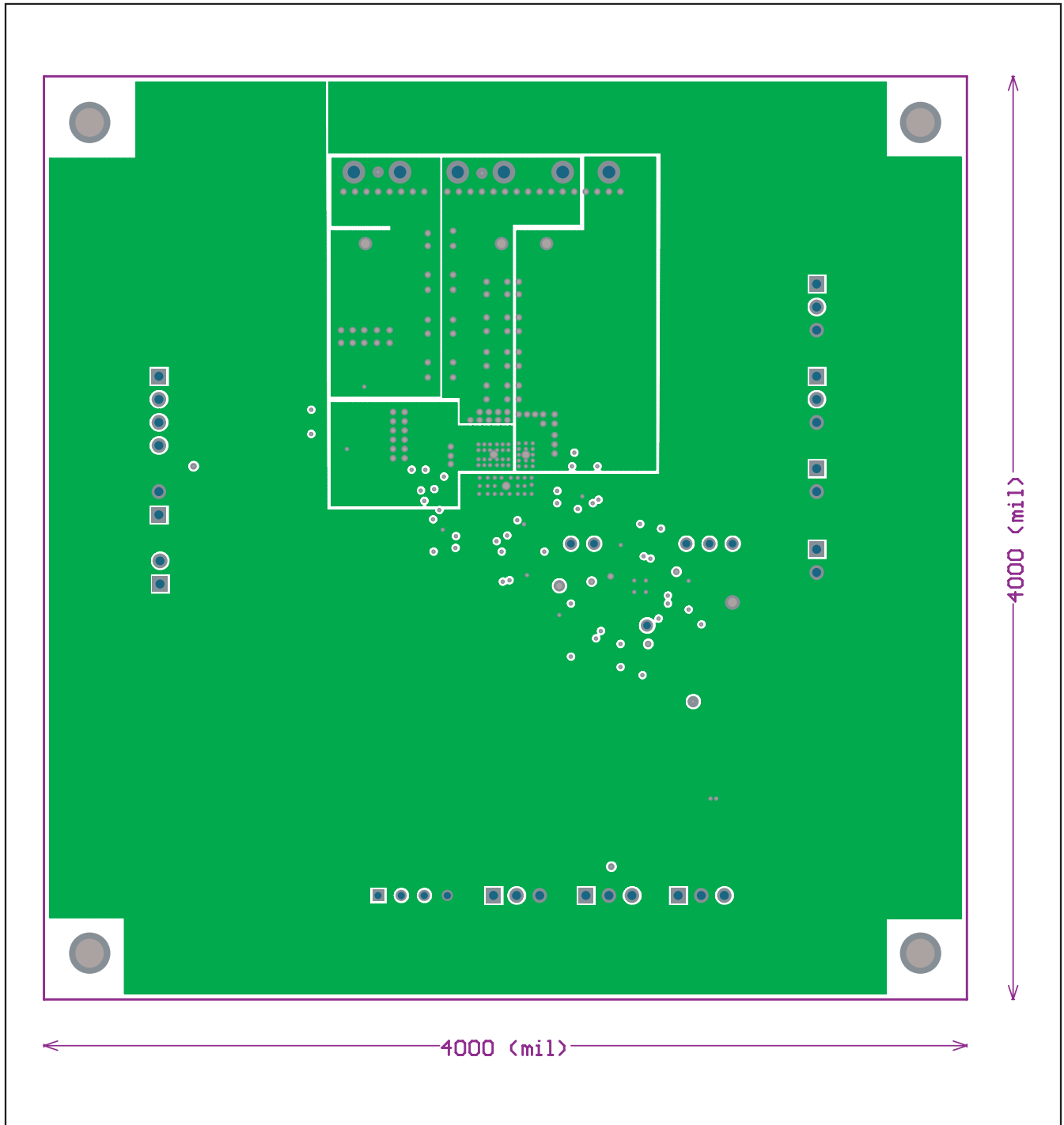

Figure 6. MAX8655 EV Kit PCB Layout—Inner Layer 3

# MAX8655 Evaluation Kit

Evaluates: MAX8655/MAX8688

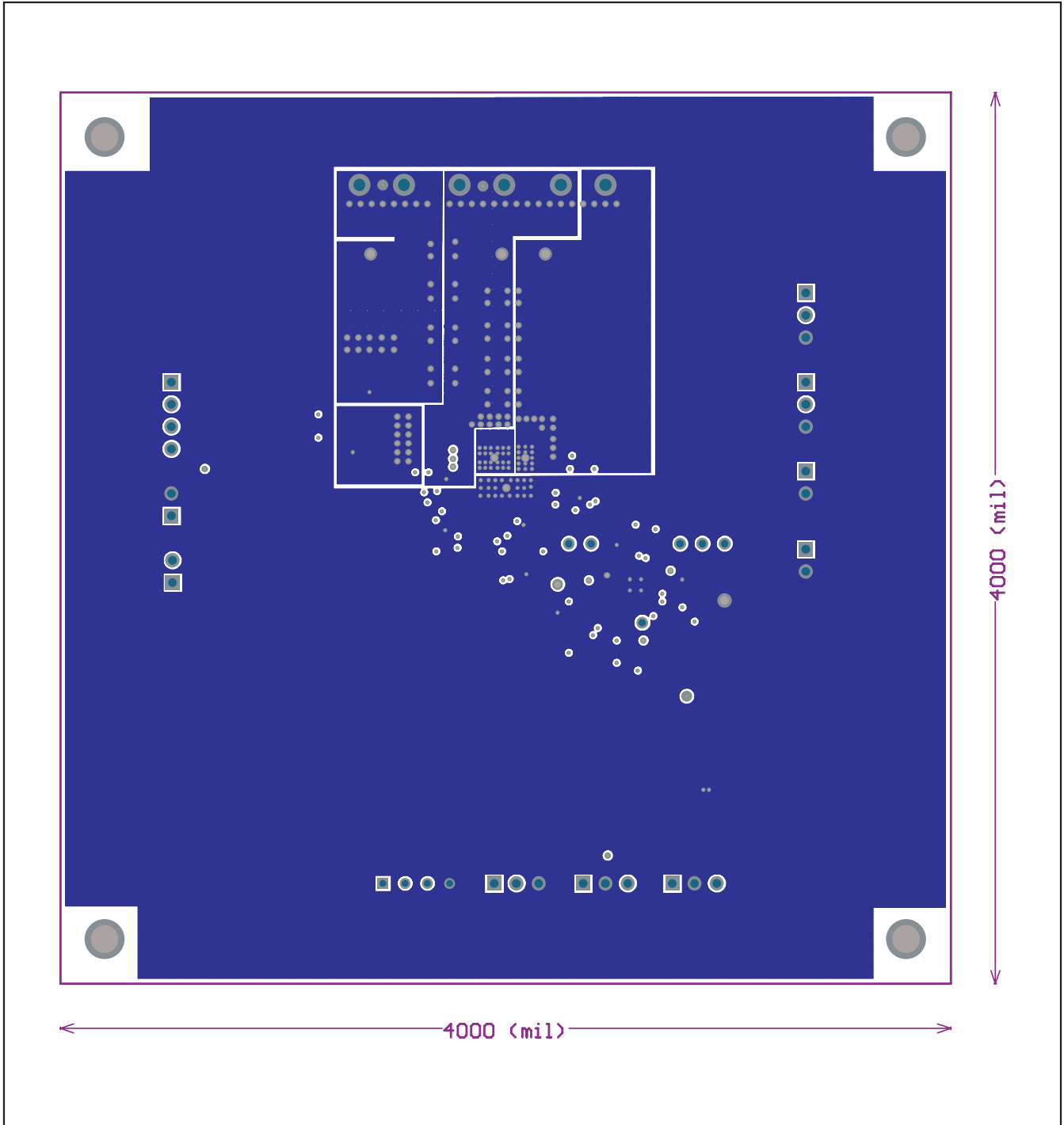

Figure 7. MAX8655 EV Kit PCB Layout—Inner Layer 4

# MAX8655 Evaluation Kit

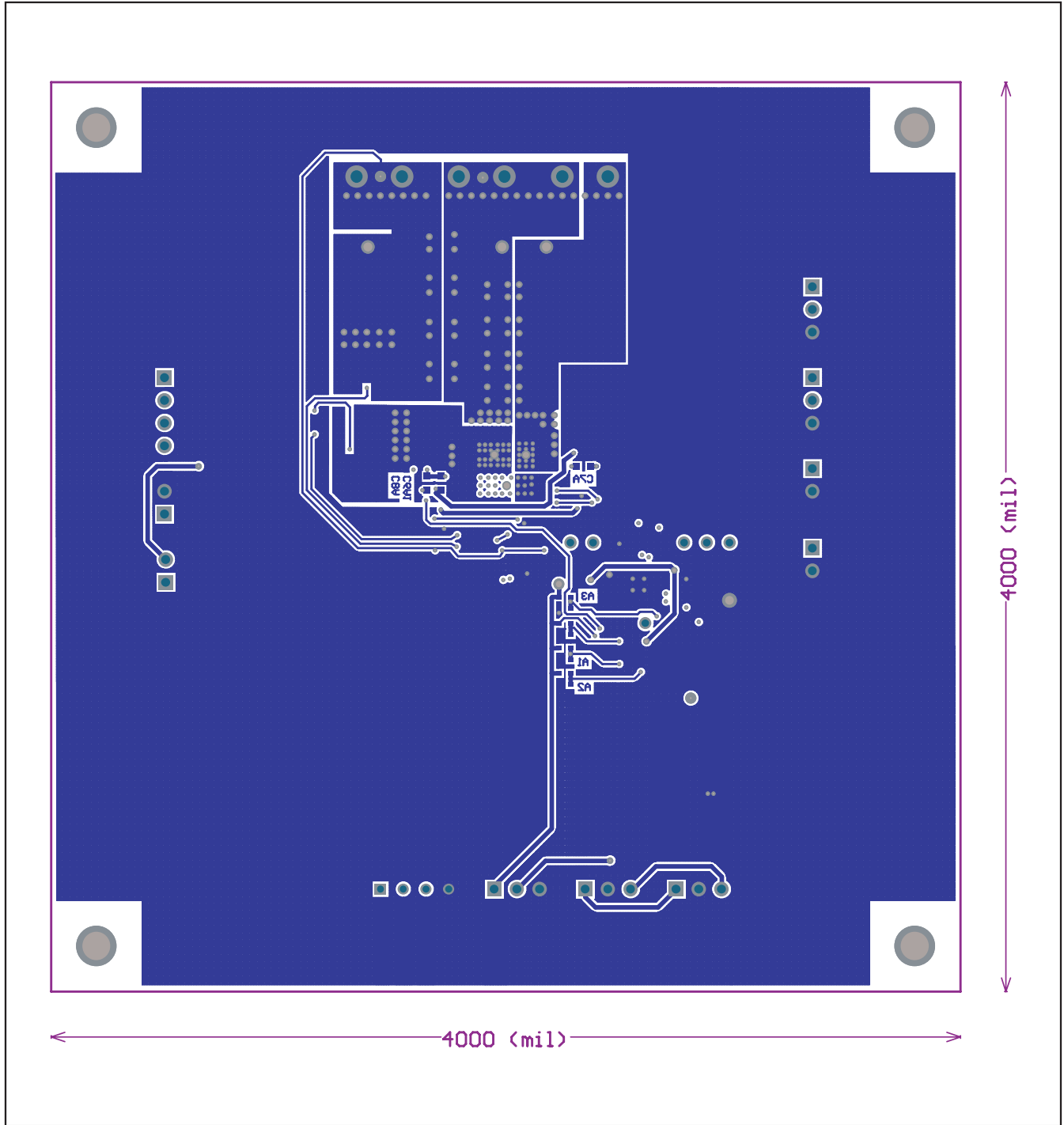

Figure 8. MAX8655 EV Kit PCB Layout—Solder Side

Maxim cannot assume responsibility for use of any circuitry other than circuitry entirely embodied in a Maxim product. No circuit patent licenses are implied. Maxim reserves the right to change the circuitry and specifications without notice at any time.

14 **Maxim Integrated Products, 120 San Gabriel Drive, Sunnyvale, CA 94086 408-737-7600**