



Chipsmall Limited consists of a professional team with an average of over 10 year of expertise in the distribution of electronic components. Based in Hongkong, we have already established firm and mutual-benefit business relationships with customers from,Europe,America and south Asia,supplying obsolete and hard-to-find components to meet their specific needs.

With the principle of “Quality Parts,Customers Priority,Honest Operation,and Considerate Service”,our business mainly focus on the distribution of electronic components. Line cards we deal with include Microchip,ALPS,ROHM,Xilinx,Pulse,ON,Everlight and Freescale. Main products comprise IC,Modules,Potentiometer,IC Socket,Relay,Connector.Our parts cover such applications as commercial,industrial, and automotives areas.

We are looking forward to setting up business relationship with you and hope to provide you with the best service and solution. Let us make a better world for our industry!



Contact us

Tel: +86-755-8981 8866 Fax: +86-755-8427 6832

Email & Skype: info@chipsmall.com Web: www.chipsmall.com

Address: A1208, Overseas Decoration Building, #122 Zhenhua RD., Futian, Shenzhen, China





High-Voltage, Low-Power Linear Regulators for Notebook Computers

General Description

The MAX8718/MAX8719 are micropower, 8-pin TDFN linear regulators that supply always-on, keep-alive power to CMOS RAM, real-time clocks (RTC), and microcontrollers in systems with high-voltage batteries. The circuits consist of a 100mA linear regulator and a power-good comparator (PGOOD) with fixed-output delay. Key features include wide input voltage range, low-dropout voltage, and low-quiescent supply current.

Despite a miserly 25µA (max) no-load quiescent current, the MAX8718/MAX8719 have good line- and load-transient response and excellent AC power-supply rejection. They provide a clean fixed 5V or 3.3V output (MAX8718), or an adjustable 1.24V to 28V output (MAX8719), even when subjected to fast supply-voltage changes that occur during the switchover from battery to AC-adaptor input power. The space-saving TDFN package has excellent thermal characteristics and tolerates up to 1951mW of power dissipation. Internal foldback current limiting and thermal shutdown protect the regulator from overload and thermal faults.

In addition to the main notebook-computer application, these devices are useful in other low-power, high-voltage applications ($4V < V_{IN} < 28V$) such as smart batteries, current control loops, telecom emergency power, and housekeeping power for off-line supplies.

The MAX8718/MAX8719 are available in a thermally enhanced 3mm x 3mm, 8-lead TDFN package.

Applications

- CMOS/RTC Backup Power
- Microcontroller Power
- Notebook Computers
- Smart-Battery Packs
- PDA's and Handy-Terminals
- Battery-Powered Systems

Features

- ◆ 4V to 28V Input Range
- ◆ 18µA Quiescent Supply Current
- ◆ <3µA Shutdown Supply Current
- ◆ 100mA Output Current
- ◆ 3.3V or 5V, Pin-Selectable Output (MAX8718)
- ◆ Adjustable 1.24V to 28V Output (MAX8719)
- ◆ ±2% Output Accuracy
- ◆ Thermal-Overload Protection
- ◆ Delayed Power-Good Output
- ◆ Thermally Enhanced 8-Pin TDFN Package

Ordering Information

PART	TEMP RANGE	PIN-PACKAGE	OUTPUT VOLTAGE
MAX8718ETA	-40°C to +85°C	8 TDFN 3mm x 3mm	3.3V/5V
MAX8719ETA	-40°C to +85°C	8 TDFN 3mm x 3mm	Adjustable

Pin Configuration

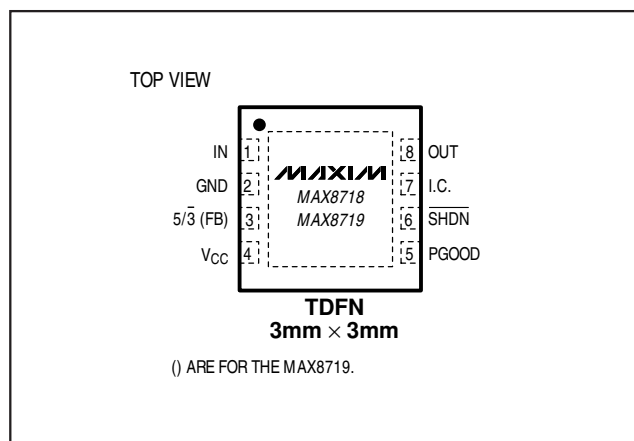

MAX8718/MAX8719

High-Voltage, Low-Power Linear Regulators for Notebook Computers

ABSOLUTE MAXIMUM RATINGS

IN to GND	-0.3V to +30V
SHDN to GND	-0.3V to (V _{IN} + 0.3V)
5/3 (MAX8718) to GND	-0.3V to +6V
FB (MAX8719) to GND	-0.3V to +6V
OUT (MAX8718) to GND	-0.3V to +6V
OUT (MAX8719) to GND	-0.3V to +30V
V _{CC} to GND (MAX8718)	-0.3V to +6V
V _{CC} to GND (MAX8719)	-0.3V to +2.7V
PGOOD to GND	-0.3V to +30V

I.C. to GND	-0.3V to +6V
OUT Short Circuit to GND	30s
Continuous Power Dissipation (T _A = +70°C)	
8-Pin TDFN (derate 24.4mW/°C above +70°C)	1951mW
Operating Temperature Range	-40°C to +85°C
Junction Temperature	+150°C
Storage Temperature Range	-65°C to +150°C
Lead Temperature (soldering, 10s)	+300°C

Stresses beyond those listed under "Absolute Maximum Ratings" may cause permanent damage to the device. These are stress ratings only, and functional operation of the device at these or any other conditions beyond those indicated in the operational sections of the specifications is not implied. Exposure to absolute maximum rating conditions for extended periods may affect device reliability.

ELECTRICAL CHARACTERISTICS

(Circuit of Figure 1. V_{IN} = 15V, I_{OUT} = 5μA, T_A = 0°C to +85°C. Typical values are at T_A = +25°C, unless otherwise noted.) (Note 1)

PARAMETER	SYMBOL	CONDITIONS	MIN	TYP	MAX	UNITS
Input Voltage Range	V _{IN}		4		28	V
Supply Current (MAX8718)	I _{IN}	SHDN = IN, T _A = +25°C		12	18	μs
		SHDN = IN, V _{IN} = 6V to 28V			25	μA
V _{CC} Input Current (MAX8719)		0V < V _{CC} < 2.7V, T _A = +25°C	-0.1		+0.1	μA
		0V < V _{CC} < 2.7V, T _A = 0°C to +85°C		0.04		
V _{CC} Input Current (MAX8718)		0V < V _{CC} < 5.5V, T _A = +25°C			3.4	μA
		0V < V _{CC} < 5.5V, T _A = 0°C to +85°C		2.3		
OUT Minimum Load Current					5	μA
Shutdown Supply Current		SHDN = 0V		1.2	3	μA
Dropout Supply Current		V _{OUT} set to 5V, V _{IN} = 4.7V		85		μA
OUT Output Voltage (MAX8718)		V _{IN} = 6V to 28V, I _{LOAD} = 1mA, 5/3 = GND, T _A = +25°C	3.26	3.33	3.40	V
		V _{IN} = 6V to 28V, I _{LOAD} = 1mA, 5/3 = OUT, T _A = +25°C	4.95	5.05	5.15	
		V _{IN} = 6V to 28V, I _{LOAD} = 5μA to 100mA, 5/3 = GND	3.15		3.48	
		V _{IN} = 6V to 28V, I _{LOAD} = 5μA to 100mA, 5/3 = OUT	4.75		5.25	
FB Threshold (MAX8719)	V _{FB}	FB = OUT, V _{IN} = 6V to 28V, I _{LOAD} = 1mA	1.215	1.240	1.265	V
		FB = OUT, V _{IN} = 6V to 28V, I _{LOAD} = 5μA to 100mA (Note 2)	1.18		1.28	
FB Input Current (MAX8719)	I _{FB}	V _{FB} = 1.3V, T _A = +25°C	-30		+30	nA
		V _{FB} = 1.3V, T _A = 0°C to +85°C		15		
5/3 Input Current (MAX8718)	I _{5/3}	V _{5/3} = 5V, T _A = +25°C	-30		+30	nA
		V _{5/3} = 5V, T _A = 0°C to +85°C		2		
Dropout Voltage	V _{DROPOUT}	I _{LOAD} = 100mA (Note 3)			560	mV

High-Voltage, Low-Power Linear Regulators for Notebook Computers

MAX8718/MAX8719

ELECTRICAL CHARACTERISTICS (continued)

(Circuit of Figure 1. $V_{IN} = 15V$, $I_{OUT} = 5\mu A$, $T_A = 0^\circ C$ to $+85^\circ C$. Typical values are at $T_A = +25^\circ C$, unless otherwise noted.) (Note 1)

PARAMETER	SYMBOL	CONDITIONS	MIN	TYP	MAX	UNITS
Output Current Limit	I_{LIM}	$V_{IN} = 6V$, $T_A = +25^\circ C$	210			mA
		$V_{OUT} = 0$, $V_{IN} = 6V$	125		340	
Output Reverse Leakage Current		V_{OUT} forced to 5.5V, IN = unconnected	70			μA
Capacitive Load Requirements		MAX8718	0.16			$\mu F/mA$
		MAX8719	0.23			
Startup Time Response		Rising edge of IN or \overline{SHDN} to OUT within spec limits, $C_{OUT} = 10\mu F$, $R_{LOAD} = 500\Omega$, $V_{OUT} = 5V$	1			ms
Startup Output Overshoot		$C_{OUT} = 10\mu F$, $R_{LOAD} = 500\Omega$, OUT within 90% of the nominal output voltage	0.5			%
V_{CC} Threshold (MAX8718)		$T_A = +25^\circ C$, rising edge only	$0.88 \times V_{OUT}$	$0.9 \times V_{OUT}$	$0.92 \times V_{OUT}$	V
		$0^\circ C < T_A < +85^\circ C$, rising edge only	$0.85 \times V_{OUT}$	$0.9 \times V_{OUT}$	$0.95 \times V_{OUT}$	
V_{CC} Threshold (MAX8719)		$T_A = +25^\circ C$, rising edge only	$0.88 \times V_{FB}$	$0.9 \times V_{FB}$	$0.92 \times V_{FB}$	V
		$0^\circ C < T_A < +85^\circ C$, rising edge only	$0.85 \times V_{FB}$	$0.9 \times V_{FB}$	$0.95 \times V_{FB}$	
V_{CC} to PGOOD Delay		V_{TH} to ($V_{TH} - 100mV$)	4.5			μs
PGOOD Active-Timeout Period			100	185	300	ms
PGOOD Output Leakage Current		PGOOD = 5.5V, $V_{CC} = 5.5V$	0.1			μA
PGOOD Output Low Voltage		$I_{SINK} = 1.6mA$, $V_{CC} = GND$	0.3			V
V_{CC} Input Hysteresis			2			%
Thermal-Shutdown Threshold		$V_{\overline{SHDN}} = 0$ or 15V, $20^\circ C$ hysteresis	+165			$^\circ C$
\overline{SHDN} Input Low Voltage			0.25			V
\overline{SHDN} Input High Voltage			1.4			V
\overline{SHDN} Input Bias Current		$V_{\overline{SHDN}} = 0$ or 15V, $T_A = 0^\circ C$ to $+85^\circ C$	-1	+0.1	+1	μA

High-Voltage, Low-Power Linear Regulators for Notebook Computers

MAX8718/MAX8719

ELECTRICAL CHARACTERISTICS

(Circuit of Figure 1 $V_{IN} = 15V$, $I_{OUT} = 5\mu A$, $T_A = -40^{\circ}C$ to $+85^{\circ}C$, unless otherwise noted.) (Note 4)

PARAMETER	SYMBOL	CONDITIONS	MIN	TYP	MAX	UNITS
Input Voltage Range	V_{IN}		4		28	V
Supply Current (MAX8718)	I_{IN}	$\overline{SHDN} = IN$, $V_{IN} = 6V$ to $28V$			25	μA
Supply Current (MAX8719)	I_{IN}	$\overline{SHDN} = IN$, $V_{IN} = 6V$ to $28V$			25	μA
OUT Minimum Load Current					5	μA
Shutdown Supply Current		$\overline{SHDN} = 0V$			3	μA
OUT Output Voltage (MAX8718)		$V_{IN} = 6V$ to $28V$, $I_{LOAD} = 5\mu A$ to $100mA$, $5/\overline{3} = GND$	3.10		3.48	V
		$V_{IN} = 6V$ to $28V$, $I_{LOAD} = 5\mu A$ to $100mA$, $5/\overline{3} = OUT$	4.72		5.25	
FB Threshold (MAX8719)	V_{FB}	$FB = OUT$, $V_{IN} = 6V$ to $28V$, $I_{LOAD} = 1mA$	1.215		1.265	V
		$FB = OUT$, $V_{IN} = 6V$ to $28V$, $I_{LOAD} = 5\mu A$ to $100mA$ (Note 2)	1.18		1.28	
FB Input Current (MAX8719)	I_{FB}	$V_{FB} = 1.3V$	-40		+40	nA
$5/\overline{3}$ Input Current (MAX8718)	$I_{5/\overline{3}}$	$V_{5/\overline{3}} = 5V$	-30		+30	nA
Dropout Voltage	$V_{DROPOUT}$	$I_{LOAD} = 100mA$ (Note 3)			560	mV
Output Current Limit	I_{LIM}	$V_{OUT} = 0$, $V_{IN} = 6V$	125		375	mA
Capacitive Load Requirements		MAX8718	0.16			$\mu F/mA$
		MAX8719	0.23			
Startup Time Response		Rising edge of IN or \overline{SHDN} to OUT within spec limits, $C_{OUT} = 10\mu F$, $R_{LOAD} = 500\Omega$, $V_{OUT} = 5V$			1	ms
V_{CC} Threshold (MAX8718)		$-40^{\circ}C < T_A < +85^{\circ}C$, rising edge only	$0.85 \times V_{OUT}$		$0.95 \times V_{OUT}$	V
V_{CC} Threshold (MAX8719)		$-40^{\circ}C < T_A < +85^{\circ}C$, rising edge only	$0.85 \times V_{FB}$		$0.95 \times V_{FB}$	V
PGOOD Active-Timeout Period			100		300	ms
PGOOD Output Low Voltage		$I_{SINK} = 1.6mA$, $V_{CC} = GND$			0.3	V
\overline{SHDN} Input Low Voltage					0.25	V
\overline{SHDN} Input High Voltage			1.4			V
\overline{SHDN} Input Bias Current		$V_{\overline{SHDN}} = 0$ or $15V$, $T_A = -40^{\circ}C$ to $+85^{\circ}C$	-1		+1	μA

Note 1: Limits are 100% production tested at $T_A = +25^{\circ}C$. Limits over the operating temperature range are guaranteed through correlation using standard quality control (SQC) methods.

Note 2: Pulse test at $V_{IN} = 28V$, $I_{OUT} = 100mA$ to avoid exceeding package power-dissipation limits.

Note 3: Dropout voltage is tested by reducing the input voltage until V_{OUT} drops to 100mV below its nominal value as measured with V_{IN} starting 2V above V_{OUT} .

Note 4: Specifications to $-40^{\circ}C$ are guaranteed by design, not production tested.

High-Voltage, Low-Power Linear Regulators for Notebook Computers

Typical Operating Characteristics

(Circuit of Figure 1. $V_{IN} = 15V$, $V_{OUT} = 3.3V$, $T_A = +25^\circ C$, unless otherwise noted.)

MAX8718/MAX8719

SAFE LOAD-CURRENT OPERATING AREA vs. SUPPLY VOLTAGE

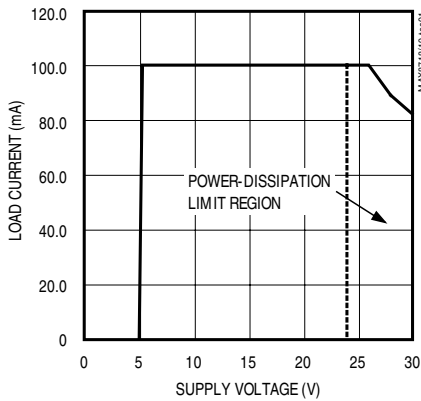

GROUND CURRENT vs. SUPPLY VOLTAGE AT VARIOUS LOADS

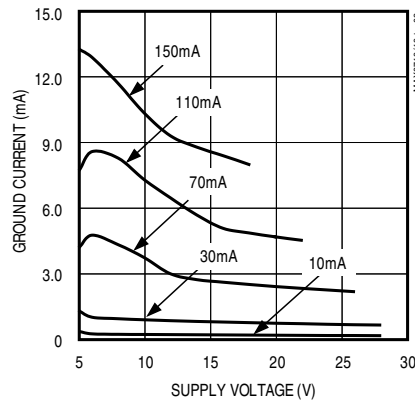

SUPPLY CURRENT vs. SUPPLY VOLTAGE

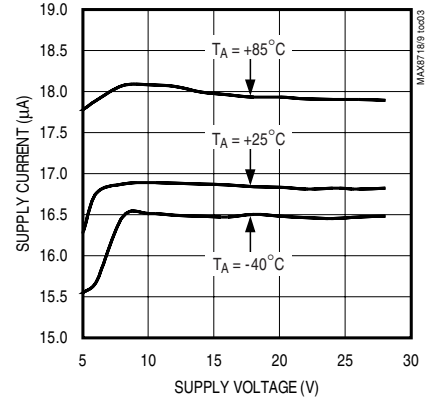

SHUTDOWN SUPPLY CURRENT vs. SUPPLY VOLTAGE

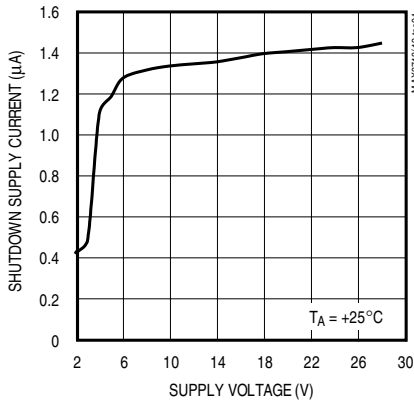

SUPPLY CURRENT vs. TEMPERATURE

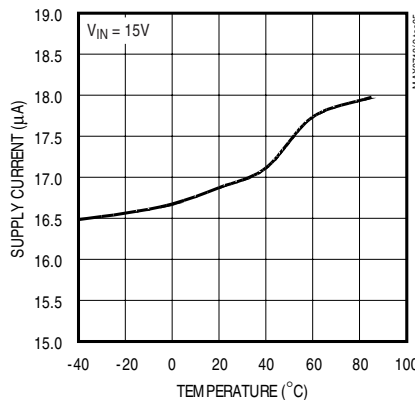

RIPPLE REJECTION vs. FREQUENCY

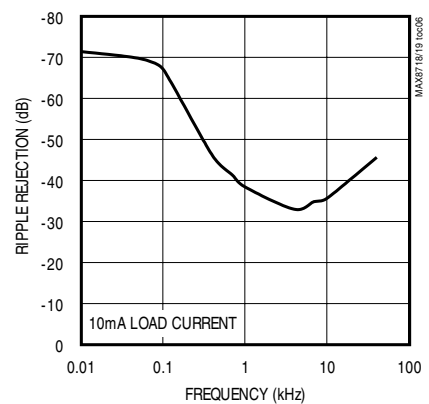

LOAD-TRANSIENT RESPONSE

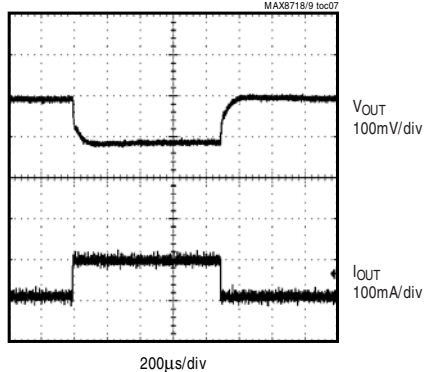

LINE-TRANSIENT RESPONSE

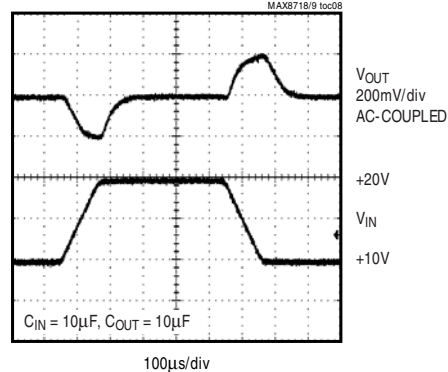

High-Voltage, Low-Power Linear Regulators for Notebook Computers

Typical Operating Characteristics (continued)

(Circuit of Figure 1. $V_{IN} = 15V$, $V_{OUT} = 3.3V$, $T_A = +25^\circ C$, unless otherwise noted.)

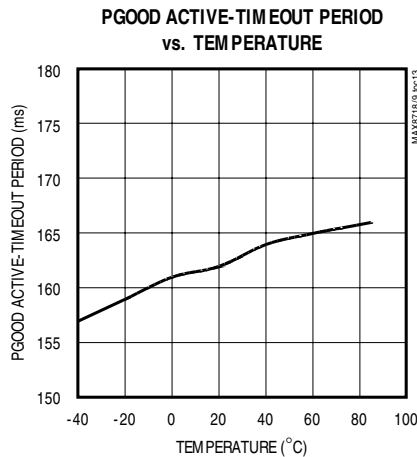
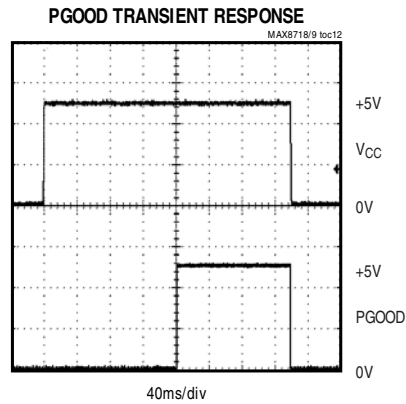
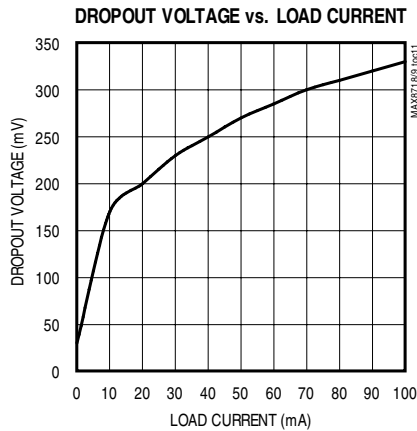
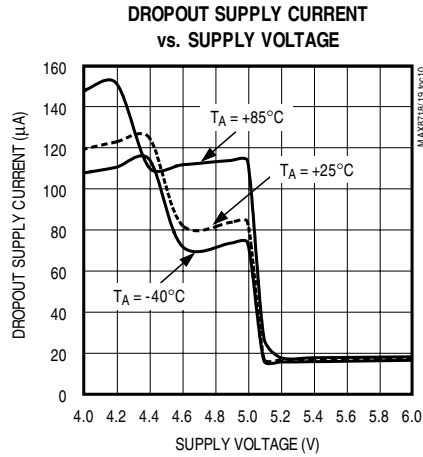
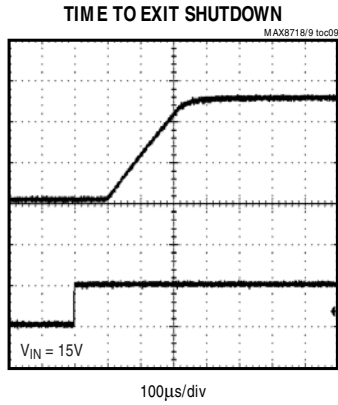

High-Voltage, Low-Power Linear Regulators for Notebook Computers

Pin Description

PIN		NAME	FUNCTION
MAX8718	MAX8719		
1	1	IN	Positive Supply Input. Connect to a +4V to +28V supply.
2	2	GND	Ground
3	—	5/3	Preset Output-Voltage Select Input. Connect 5/3 to GND for 3.3V output, or to OUT for 5V output.
—	3	FB	Feedback Input. Regulates to 1.24V nominally.
4	4	V _{CC}	PGOOD Sense Input
5	5	PGOOD	Power-Good Output
6	6	SHDN	Shutdown Control Input
7	7	I.C.	Internal Connection. This pin is internally connected for test purposes; leave it unconnected in the application.
8	8	OUT	100mA Regulator Output

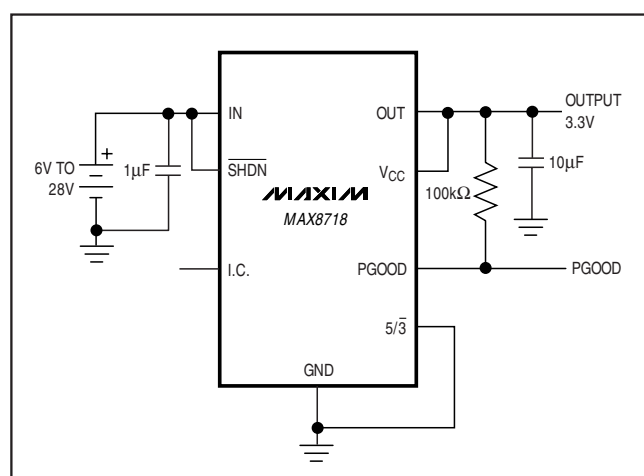

Figure 1. Typical Operating Circuit of the MAX8718

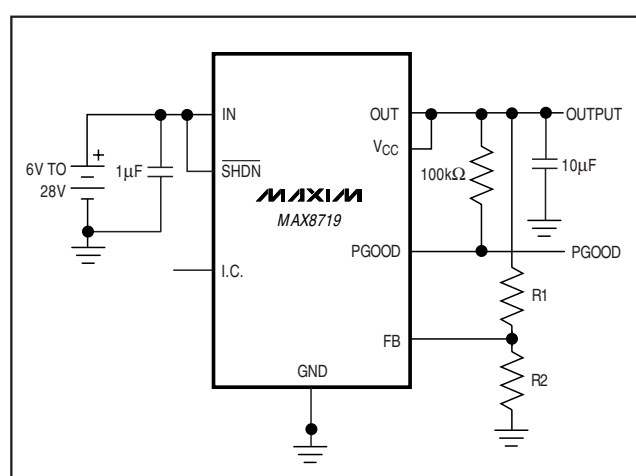

Figure 2. Typical Operating Circuit of the MAX8719

Detailed Description

The MAX8718/MAX8719 low-quiescent-current linear regulators are designed primarily for high-input-voltage applications. The MAX8718 supplies a preselected 3.3V or 5.0V output for loads up to 100mA (Figure 1). The MAX8719 provides an adjustable voltage from 1.24V to 28V (Figure 2). The maximum output current is a function of the package's maximum power dissipation for a given temperature. A 5µA load is required to maintain output regulation.

The MAX8718's output voltage is fed back through an internal resistive voltage-divider connected to OUT. Set the output voltage to either 5.0V or 3.3V with the 5/3

pin. Select the 5V output by connecting 5/3 to OUT, or the 3.3V output by connecting 5/3 to GND.

The MAX8719's output is adjustable with an external resistive voltage-divider. The typical feedback threshold is 1.24V (see the *Setting the MAX8719 Output Voltage* section). See Figure 3 for the *MAX8718/MAX8719 Functional Diagram*.

Shutdown

The device enters shutdown mode when SHDN is low. In shutdown mode, the internal pnp power transistor, control circuit, reference, and all biases turn off, reducing the supply current to below 3µA. Connect SHDN to IN for automatic startup.

High-Voltage, Low-Power Linear Regulators for Notebook Computers

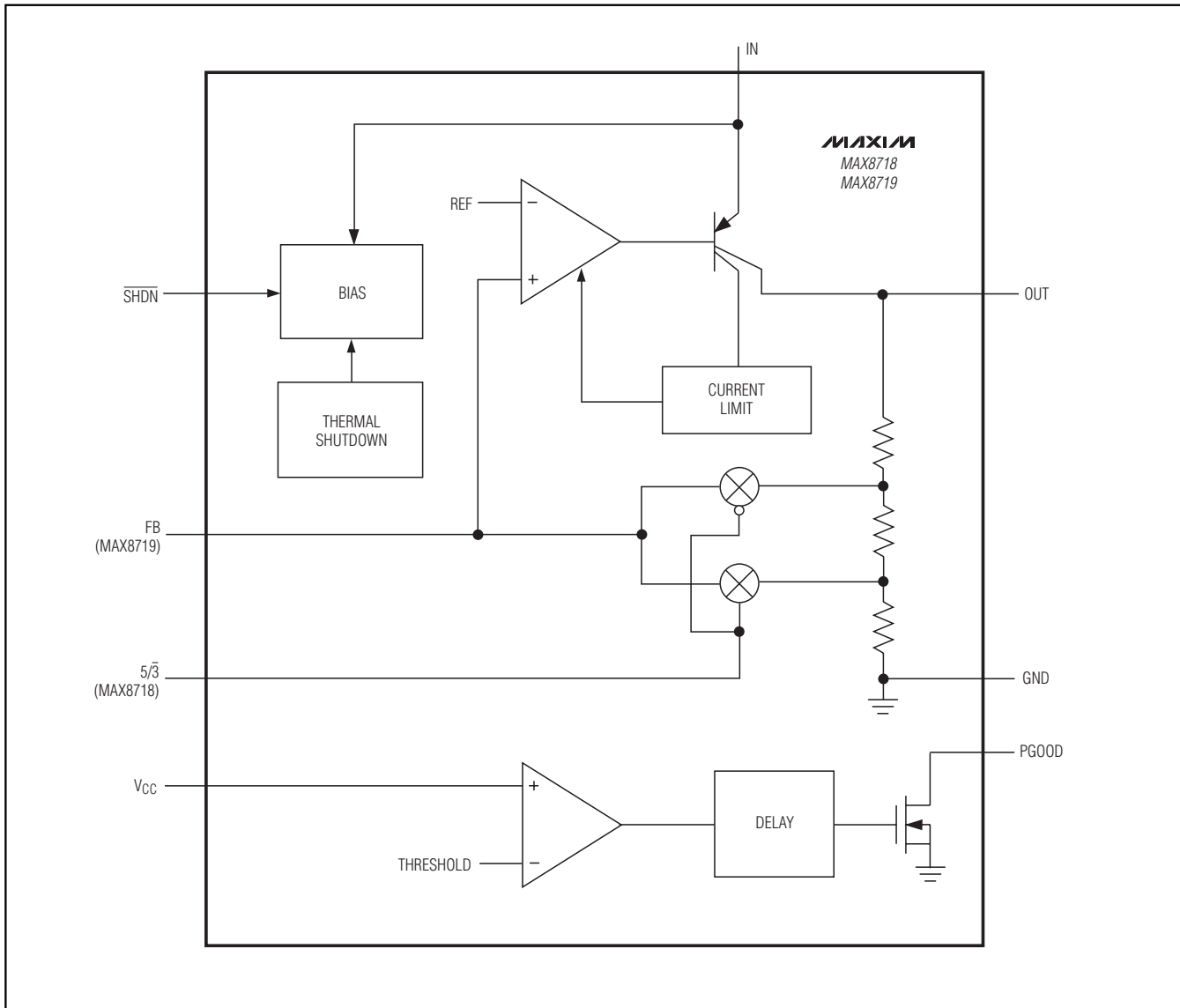

Figure 3. MAX8718/MAX8719 Functional Diagram

Current Limit

Output current is limited to 210mA (typ). The current limit exceeds the 100mA (min) safe operating limit. The output can be shorted to ground for 30 seconds without damaging the part.

Thermal-Overload Protection

When the junction temperature exceeds $T_J = +165^\circ\text{C}$, an internal thermal sensor sends a signal to the shutdown logic, turning off the pass transistor and allowing the IC to cool. The thermal sensor turns the pass tran-

sistor on again after the IC's junction temperature cools by 20°C (typ), causing the output to pulse on and off during continuous thermal-overload conditions.

Operating Region and Power Dissipation

Maximum power dissipation depends on the thermal resistance of the case and circuit board, the temperature difference between the die junction and ambient air, and the rate of airflow. The device's power dissipation is $P = I_{OUT} \times (V_{IN} - V_{OUT})$. The power dissipation at $+70^\circ\text{C}$ ambient is 1951mW (see the *Absolute Maximum*

High-Voltage, Low-Power Linear Regulators for Notebook Computers

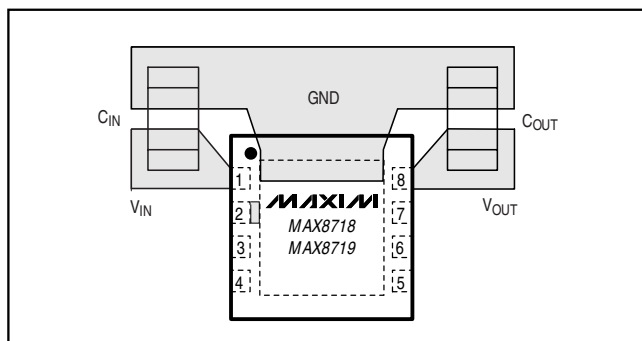

Figure 4. Layout of High-Current Paths

Ratings). The thermal resistance junction-to-case of the TDFN package is 41°C/W, and the maximum safe junction temperature is +150°C.

The GND pin and backside pad performs the dual function of providing an electrical connection to ground and channeling heat away from the package. Connect GND and the backside pad to ground using a metal trace or ground plane. The package's overall thermal resistance varies inversely with the copper PC board area attached to the part. To achieve rated thermal resistance, a copper region of at least 650mm² should be attached to the MAX8718/MAX8719s' case.

Applications Information

Setting the MAX8719's Output Voltage

Set the MAX8719's output voltage with a resistive voltage-divider (R1 and R2 in Figure 3). Choose R2 = 125kΩ or less to maintain a 10μA minimum load on OUT. Calculate R1 using the following equation:

$$R1 = R2 \times \left(\frac{V_{OUT}}{V_{FB}} - 1 \right)$$

where $V_{FB} = 1.24V$ (typ).

Capacitor Selection

Use a 0.1μF (min) capacitor on the input. Higher values improve the line-transient response.

Use a 1μF (min) capacitor on the output, or a 15μF capacitor for the full 100mA load current. Otherwise, use a 1μF plus 0.16μF/mA (0.23μF/mA for the MAX8719). For output voltages less than 3.3V, use 15μF instead of 10μF. The output capacitor's equivalent series resistance (ESR) must be less than 1Ω for stable operation.

Output-Voltage Noise

The MAX8718/MAX8719 typically exhibit 5mV_{P-P} of noise during normal operation. This is negligible in

most applications. In applications that include analog-to-digital converters (ADCs) of more than 12 bits, consider the ADC's power-supply rejection specifications.

Transient Response

The *Typical Operating Characteristics* show the MAX8718/MAX8719s' load-transient response. When a step-in load current is applied, there are two components to the regulator's response. There is an instantaneous step in the output voltage due to the output capacitor's ESR and the regulator's finite output impedance. The second, slower component is the regulator's active correction to the output voltage. Typical step changes in the OUT load current from 10mA to 20mA produce 20mV transients.

Power-Good Output (PGOOD)

The MAX8718/MAX8719 include an independent power-good monitor. This circuit has an uncommitted sense input (V_{CC}) that can be connected to the regulator's output or similar voltage. In the MAX8718, the comparator threshold tracks the output set point according to the state of 5/3. In the MAX8719, the comparator threshold is set to the feedback reference voltage. The PGOOD output goes high when V_{CC} is greater than -10% of the regulation set point. There is a fixed 100ms (min) delay when the output goes into regulation, which helps ensure proper output-voltage settling. The PGOOD delay when transitioning out of regulation is much faster, 4.5μs (typ), which permits the system to respond as fast as possible to the out-of-regulation condition.

The power-good monitor has an open-drain output, which can be externally pulled up to OUT. The voltage rating for PGOOD is 28V.

Layout Guidelines

Good layout is important to minimize the effects of noise and ensure accurate voltage regulation. Use appropriate trace widths for the high-current paths and keep traces short to minimize parasitic inductance and capacitance. Figure 4 shows a layout of the high-current paths. Place bypass capacitors close to the IN and OUT pins. When using the MAX8719, the feedback resistors should be placed close to the device to avoid voltage drops on ground that may shift the output voltage. Connect the exposed backside paddle to as large a copper area as practical.

Chip Information

TRANSISTOR COUNT: 1298

PROCESS: BiCMOS

High-Voltage, Low-Power Linear Regulators for Notebook Computers

Package Information

(The package drawing(s) in this data sheet may not reflect the most current specifications. For the latest package outline information, go to www.maxim-ic.com/packages.)

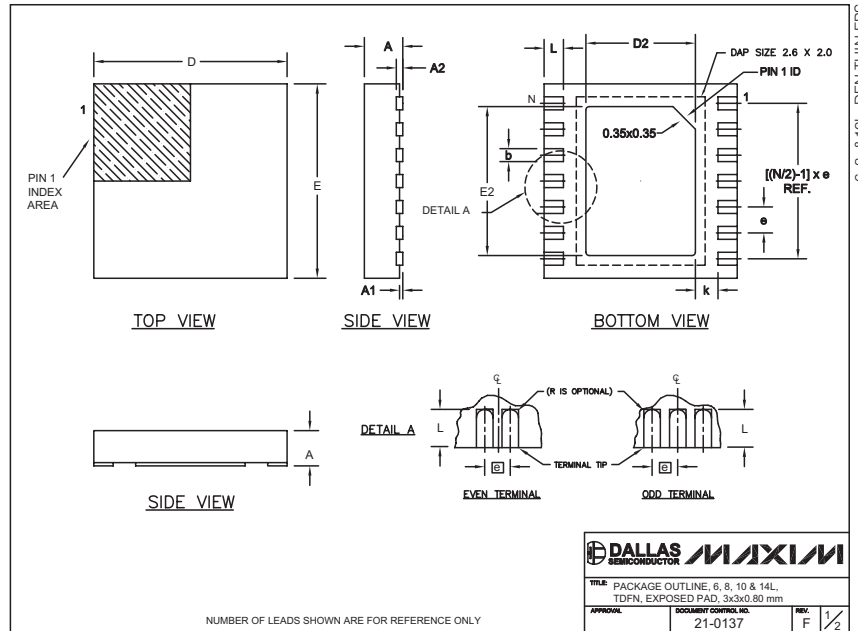

COMMON DIMENSIONS		
SYMBOL	MIN.	MAX.
A	0.70	0.80
D	2.90	3.10
E	2.90	3.10
A1	0.00	0.05
L	0.20	0.40
k	0.25 MIN.	
A2	0.20 REF.	

PACKAGE VARIATIONS							
PKG. CODE	N	D2	E2	e	JEDEC SPEC	b	[(N/2)-1] x e
T633-1	6	1.50±0.10	2.30±0.10	0.95 BSC	MO229 / WEEA	0.40±0.05	1.90 REF
T833-1	8	1.50±0.10	2.30±0.10	0.65 BSC	MO229 / WEEC	0.30±0.05	1.95 REF
T1033-1	10	1.50±0.10	2.30±0.10	0.50 BSC	MO229 / WEED-3	0.25±0.05	2.00 REF
T1433-1	14	1.70±0.10	2.30±0.10	0.40 BSC	----	0.20±0.03	2.40 REF
T1433-2	14	1.70±0.10	2.30±0.10	0.40 BSC	----	0.20±0.03	2.40 REF

NOTES:
 1. ALL DIMENSIONS ARE IN mm. ANGLES IN DEGREES.
 2. COPLANARITY SHALL NOT EXCEED 0.08 mm.
 3. WARPAGE SHALL NOT EXCEED 0.10 mm.
 4. PACKAGE LENGTH/PACKAGE WIDTH ARE CONSIDERED AS SPECIAL CHARACTERISTIC(S).
 5. DRAWING CONFORMS TO JEDEC MO229, EXCEPT DIMENSIONS "D2" AND "E2", AND T1433-1 & T1433-2.
 6. "N" IS THE TOTAL NUMBER OF LEADS.

MAXIM SEMICONDUCTOR
 TITLE: PACKAGE OUTLINE, 6, 8, 10 & 14L, TDFN, EXPOSED PAD, 3x3x0.80 mm
 APPROVAL: DOCUMENT CONTROL NO. 21-0137 REV. F 1/2

Maxim cannot assume responsibility for use of any circuitry other than circuitry entirely embodied in a Maxim product. No circuit patent licenses are implied. Maxim reserves the right to change the circuitry and specifications without notice at any time.

10 _____ Maxim Integrated Products, 120 San Gabriel Drive, Sunnyvale, CA 94086 408-737-7600