



Chipsmall Limited consists of a professional team with an average of over 10 year of expertise in the distribution of electronic components. Based in Hongkong, we have already established firm and mutual-benefit business relationships with customers from,Europe,America and south Asia,supplying obsolete and hard-to-find components to meet their specific needs.

With the principle of “Quality Parts,Customers Priority,Honest Operation,and Considerate Service”,our business mainly focus on the distribution of electronic components. Line cards we deal with include Microchip,ALPS,ROHM,Xilinx,Pulse,ON,Everlight and Freescale. Main products comprise IC,Modules,Potentiometer,IC Socket,Relay,Connector.Our parts cover such applications as commercial,industrial, and automotives areas.

We are looking forward to setting up business relationship with you and hope to provide you with the best service and solution. Let us make a better world for our industry!



## Contact us

Tel: +86-755-8981 8866 Fax: +86-755-8427 6832

Email & Skype: info@chipsmall.com Web: www.chipsmall.com

Address: A1208, Overseas Decoration Building, #122 Zhenhua RD., Futian, Shenzhen, China





# MAX8790A Evaluation Kit

## General Description

The MAX8790A evaluation kit (EV kit) is a fully assembled and tested surface-mount PCB that evaluates the high-efficiency MAX8790A white LED (WLED) driver. The MAX8790A EV kit utilizes a step-up DC-DC converter to generate the voltage required to drive up to six strings of eight surface-mount WLEDs. The EV kit is powered by a 7V to 21V input power supply (single-supply mode) and can be configured to provide a fixed 20mA or adjustable 15mA to 25mA full-scale LED current. In addition, the MAX8790A provides LED current control through either analog or digitally adjusted pulse-width modulation (DPWM) dimming modes. As shipped, the MAX8790A EV kit is configured for evaluation with two strings of eight WLEDs.

## Features

- ◆ 7V to 21V Input Range
- ◆ 86% Efficiency (VIN = 12V, Load = Two WLED Strings)
- ◆ WLED Drives Up to 25mA/String
- ◆ Drives Two Strings of Eight WLEDs (Capable of Driving Up to Six Strings)
- ◆ Analog or Direct DPWM Dimming Control
- ◆ 100:1 Dimming Range
- ◆ 750kHz PWM Switching Frequency (Selectable: 1MHz or 500kHz, Component Change Required)
- ◆ Fully Assembled and Tested

## Ordering Information

PART	TYPE
MAX8790AEVKIT+	EV Kit

+Denotes lead-free and RoHS-compliant.

## Component List

DESIGNATION	QTY	DESCRIPTION
C1, C3, C4	3	0.1 $\mu$ F $\pm$ 10%, 50V X7R ceramic capacitors (0603) Murata GRM188R71H104K TDK C1608X7R1H104K
C2	1	1 $\mu$ F $\pm$ 10%, 6.3V X5R ceramic capacitor (0603) Murata GRM188R60J105K TDK C1608X5R1A105K
C5	1	2.2 $\mu$ F $\pm$ 10%, 50V X7R ceramic capacitor (1206) Murata GRM31CR71H225K KEMET C1206C225K5RAC
C6, C8, C11–C16	0	Not installed, ceramic capacitors (1206)
C7	1	10 $\mu$ F $\pm$ 10%, 25V X5R ceramic capacitor (1206) Murata GRM31CR61E106KA TDK C3216X5R1E106K
C9, C10, C17	0	Not installed, ceramic capacitors (0603)

DESIGNATION	QTY	DESCRIPTION
D1	1	2A, 40V Schottky diode (M-Flat) Toshiba CMS11 (TE12L, Q) Nihon EC21QS04
D2–D17	16	White LEDs Nichia NSSW008C OPTEK OVSRWACR6
D18–D49	0	Not installed, white LEDs
JU1, JU3, JU6, JU7	4	3-pin headers
JU2, JU4, JU5, JU12	4	2-pin headers
JU8–JU11, JU13	0	Not installed, 3-pin headers
L1	1	4.7 $\mu$ H, 2.15A, 64.1m $\Omega$ power inductor TDK LTF5022T-4R7N2R0 Sumida CDRH5D16-4R7 (1.8mm)
N1	1	60V, 2.8A n-channel MOSFET (6 TSOP) SANYO Semiconductor CPH6424 (Top Mark: ZA) Fairchild Semiconductor FDC5612 (Top Mark: 562)

Evaluates: MAX8790A

# MAX8790A Evaluation Kit

## Component List (continued)

DESIGNATION	QTY	DESCRIPTION
R1	1	51k $\Omega$ $\pm$ 5% resistor (0603)
R2	1	100k $\Omega$ potentiometer, multiturn
R3	1	511k $\Omega$ $\pm$ 1% resistor (0603)
R4	1	37.4k $\Omega$ $\pm$ 1% resistor (0603)
R5	1	1M $\Omega$ $\pm$ 1% resistor (0603)
R6	1	56m $\Omega$ $\pm$ 1%, 0.5W resistor (1206) IRC LRC-LRF-1206LF-01-R056-F Vishay WSL1206R0560FEA18
R7	0	Not installed, resistor—short (PC trace) (0603)

DESIGNATION	QTY	DESCRIPTION
R8	1	1.2k $\Omega$ $\pm$ 5% resistor (0603)
R9, R10	2	100k $\Omega$ $\pm$ 5% resistors (0603)
R11–R16	0	Not installed, resistors (0603)
U1	1	Six-string white LED driver (20 TQFN) Maxim MAX8790AETP+
—	8	Shunts
—	1	PCB: MAX8790A Evaluation Kit+

## Component Suppliers

SUPPLIER	PHONE	WEBSITE
Fairchild Semiconductor	888-522-5372	www.fairchildsemi.com
IRC, Inc.	361-992-7900	www.irctt.com
KEMET Corp.	864-936-6300	www.kemet.com
Murata Electronics North America, Inc.	770-436-1300	www.murata-northamerica.com
Nichia Corp.	248-352-6575	www.nichia.com
Nihon Inter Electronics Corp.	847-843-7500	www.niec.co.jp
OPTEK Technologies	972-323-2200	www.optekinc.com
SANYO Electric Co., Ltd.	619-661-6835	www.sanyodevice.com
Sumida Corp.	847-545-6700	www.sumida.com
TDK Corp.	847-803-6100	www.component.tdk.com
Toshiba America Electronic Components, Inc.	949-623-2900	www.toshiba.com/taec
Vishay	402-564-3131	www.vishay.com

**Note:** Indicate that you are using the MAX8790A when contacting these component suppliers.

## Quick Start

### Recommended Equipment

Before beginning, the following equipment is needed:

- 25V, 1A power supply (VIN)

### Procedure

The MAX8790A EV kit is fully assembled and tested. Follow the steps below to verify board operation.

**Caution: Do not turn on the power supply until all connections are completed.**

1) Verify that the shunts are installed as follows:

JUMPER	DEFAULT SHUNT POSITION
JU1, JU6, JU7	1-2
JU2, JU4	Not installed
JU3	2-3
JU5, JU12	Installed

- 2) Connect the positive terminal of the VIN power supply to the VIN pad on the EV kit and connect the ground terminal of the VIN power supply to the PGND pad on the EV kit.
- 3) Set the VIN power supply to 12V and enable its output.
- 4) Verify that both WLED strings are lit.

## Detailed Description

The MAX8790A EV kit is a high-efficiency WLED driver that utilizes a step-up DC-DC converter optimized to generate the necessary output voltage for driving six strings of WLEDs. The EV kit is powered by a 7V to 21V input power supply and can be configured to provide a fixed 20mA or adjustable 15mA to 25mA full-scale LED current.

# MAX8790A Evaluation Kit

Evaluates: MAX8790A

The EV kit is populated with two strings of eight WLEDs, but provides four additional on-board strings to allow for the evaluation of up to six total strings of eight WLEDs (48 total WLEDs). In addition, the EV kit can be used to evaluate external off-board WLED strings, providing flexibility in the layout of the WLED strings and allowing for the evaluation of more WLEDs per string. See the *White LED String Configuration* section for WLED configuration options.

LED current control is accomplished through either analog or digital dimming modes, which achieve a 100:1 dimming range. Both dimming modes utilize the pulse-width modulation (PWM) signal supplied at the BRT input pad to control the LED current sources. See the *LED Dimming Mode* section for more details.

As configured, the MAX8790A EV kit operates with a 750kHz switching frequency and an output voltage of 35V. Operating the EV kit at a different switching frequency or output voltage might require component changes. Refer to the MAX8790A IC data sheet for details on component selections.

## Input Power Supply

The MAX8790A EV kit can be evaluated with either one or two input power supplies. When using one input power supply, connect a 7V to 21V power supply to the VIN pad and configure jumper JU1 (Table 1) for single-supply operation. In single-supply operation, do not connect an external power supply or load to the VCC pad.

To utilize two input power supplies, configure jumper JU1 for dual-supply operation and connect a 4.5V to 5.5V power supply to the VCC pad and a 7V to 21V power supply to the VIN pad.

## Shutdown Mode (SHDN)

The MAX8790A is disabled by connecting SHDN to GND. When in shutdown mode, the IC quiescent current is reduced to less than 10µA (typ). The SHDN input is set through jumper JU2. See Table 2 for shutdown configurations.

**Table 1. Jumper JU1 Function**

SHUNT POSITION	INPUT SUPPLY
1-2*	Single (7V to 21V)
2-3	Dual (VIN = 7V to 21V, VCC = 4.5V to 5.5V)

\*Default position.

## Switching-Frequency Selection (OSC)

The MAX8790A EV kit is configured to operate at 750kHz, but provides the option to set the switching frequency of the step-up DC-DC converter to 500kHz or 1MHz. The switching frequency is set by installing header JU13 and configuring the shunt location as listed in Table 3. Changing the switching frequency may require different converter components. Refer to the MAX8790A IC data sheet for proper component selections.

## Setting Full-Scale LED Current (ILED(FS))

The full-scale current through each WLED string is configured by connecting ISET (pin 18) to VCC, or by tying it to GND through resistors R1 and R2. When ISET is connected to VCC the full-scale current is set to 20mA, and when pulled to GND the full-scale current is adjustable from 15mA to 25mA:

$$I_{LED(FS)} = \left( 20 \times \frac{100k\Omega}{R1 + R2} \right) mA$$

where R1 is a 51kΩ resistor and R2 is a 100kΩ potentiometer. The ISET pin is configured through jumper JU4. See Table 4 for jumper JU4 settings.

**Table 2. Jumper JU2 Function**

SHUNT POSITION	SHDN PIN	MAX8790A
Not installed*	Connected to VIN through R9	Enabled
Installed	Connected to GND	Disabled

\*Default position.

**Table 3. Jumper JU13 Function**

SHUNT POSITION	OSC PIN	OPERATING FREQUENCY
1-2	Connected to VCC	1MHz
2-3	Connected to GND	500kHz
Not installed*	Unconnected	750kHz

\*Default position.

# MAX8790A Evaluation Kit

**Table 4. Jumper JU4 Function**

SHUNT POSITION	ISET PIN	I <sub>LED</sub> (FS)
Installed	Connected to VCC	20mA
Not installed*	Connected to GND through R1 and R2	Adjustable from 15mA to 25mA

\*Default position.

### LED Dimming Mode

The MAX8790A provides a 100:1 dimming range through analog or digital control methods. In both methods, the BRT input signal is translated into a control signal for each of the six current sources. By varying the BRT duty cycle, the LED string current (I<sub>LED</sub>) is adjusted between 0mA and the full-scale current setting. See the *Setting Full-Scale LED Current (I<sub>LED</sub>(FS))* section for details on configuring the full-scale current. To select the dimming mode, configure jumper JU3 as shown in Table 5, and see the *Direct DPWM Dimming Mode* and *Analog + DPWM Dimming Mode* sections for additional information.

### Direct DPWM Dimming Mode

To enable DPWM dimming, configure jumper JU3 as listed in Table 5, and ensure that a shunt is installed across jumper JU5.

In direct DPWM dimming mode, I<sub>LED</sub> is a PWM signal whose amplitude is equal to the full-scale current setting. The duty cycle of the I<sub>LED</sub> signal is synchronized with the BRT signal, such that at 50% BRT duty cycle the I<sub>LED</sub> duty cycle are also 50%. While in direct DPWM dimming mode, the internal phase-locked loop (PLL) is not used and does not limit the BRT frequency. Refer to the MAX8790A IC data sheet for information on determining the maximum allowable BRT frequency.

### Analog + DPWM Dimming Mode

To enable analog + DPWM dimming, configure jumper JU3 as listed in Table 5, and ensure that a shunt is not installed across jumper JU5.

In analog dimming mode, I<sub>LED</sub> is a DC signal whose amplitude is modulated by the duty cycle of the BRT input signal. Therefore, at 50% BRT duty cycle, the I<sub>LED</sub> DC signal is set to 50% of the full-scale current. While in analog dimming mode, the BRT frequency is limited to the capture range of the internal PLL. The free-running frequency of the PLL is set by R3 to 244Hz, providing a capture range of 147Hz to 244Hz. Refer to the MAX8790A IC data sheet for information on configuring the PLL's free-running frequency.

This analog control scheme holds true down to a BRT duty cycle of 12.5%. Below 12.5%, the string currents are modulated through a combination of analog and digital dimming schemes. Refer to the MAX8790A IC data sheet for further details.

### White LED String Configuration

As configured, the MAX8790A EV kit is assembled with two strings of eight WLEDs (String1 and String2), but can be reconfigured to drive up to six strings of eight WLEDs. Each string has an associated 3-pin header (JU6–JU11) and feedback pin (FB1–FB6). To evaluate additional strings (String3–String6), the EV kit must be reconfigured as follows:

- 1) Populate the String\_ with either the WLED listed in the *Component List* or its equivalent.
- 2) Cut the trace (solder side) between pins 2-3 of the string's associated header-footprint (JU8–JU11).
- 3) Install a 3-pin header (JU8–JU11) and configure its shunt according to Table 6.

To evaluate the EV kit with off-board WLED strings, see the *Off-Board White LED String Configuration* section.

**Table 5. Jumpers JU3, JU5 Function**

JU3	ENA PIN	JU5 (FSET)	DIMMING MODE
1-2	Connected to VCC	Not installed (connected to GND through R3)	Analog + DPWM
2-3*	Connected to GND	Installed (connected to VCC)	Direct DPWM

\*Default position.

# MAX8790A Evaluation Kit

Evaluates: MAX8790A

**Table 6. Jumpers JU6–JU11 Function**

SHUNT POSITION	FB_ PIN	STRING_
1-2	Connected to cathode of WLED string	Enabled
2-3	Connected to GND	Disabled
Not installed	Connect to an external WLED string	On-board WLED string not used

### **Off-Board White LED String Configuration**

The MAX8790A EV kit is also used to drive off-board WLED strings. This allows the evaluation of up to 10 WLEDs per string. To evaluate external WLED strings, remove the shunts from jumpers JU6–JU12. See Table 6 for jumpers JU6–JU11 and Table 7 for jumper JU12 configurations. Removing these jumpers effectively disconnects the on-board WLED strings from between the output and feedback pins, allowing the connection of external WLED strings. For each external WLED string, connect the cathode terminal of the string to the corresponding feedback pad (FB1–FB6), and connect the anode terminal of the string to the VOUT pad. Once the external WLED strings are connected between the VOUT pad and the FB\_ pins, the EV kit can be evaluated in the same manner as with the on-board WLED strings. Evaluating more than eight WLEDs per string could require component changes. Refer to the MAX8790A IC data sheet for component selections.

**Table 7. Jumper JU12 Function**

SHUNT POSITION	VOUT
Installed*	Connected to anodes of on-board WLED strings
Not installed	Connect to anodes of off-board WLED strings

\*Default position.

**Note:** When evaluating more than eight WLEDs per string, ensure that at low currents the forward voltage drop across the strings is large enough to avoid exceeding the 28V maximum rating of the FB pins [ $V_{FB} = (V_{OUT} - V_{F\_WLEDs}) < 28V$ ].

### **LED String Capacitance**

In some LCD panel applications, a 0.1μF (typ) capacitor,  $C_{LED}$ , is placed in parallel with each LED string to improve ESD immunity. As such, the MAX8790A EV kit provides a footprint across each LED string in addition to footprints for pullup resistors on each FB\_ pin. Refer to the *LCD Panel Capacitance* section in the MAX8790A IC data sheet for more detailed information.

# Evaluates: MAX8790A

## MAX8790A Evaluation Kit

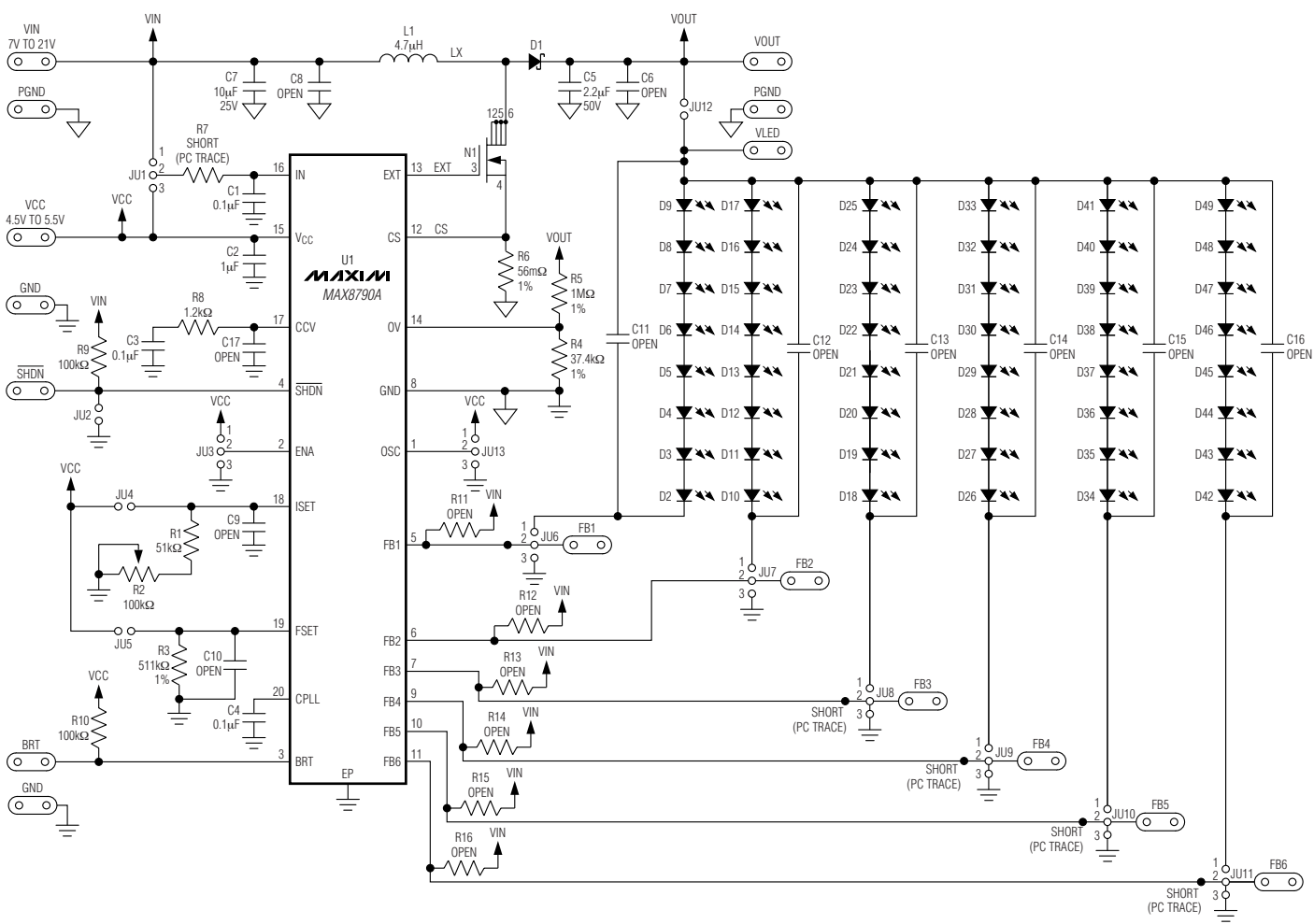

Figure 1. MAX8790A EV Kit Schematic

# MAX8790A Evaluation Kit

Evaluates: MAX8790A

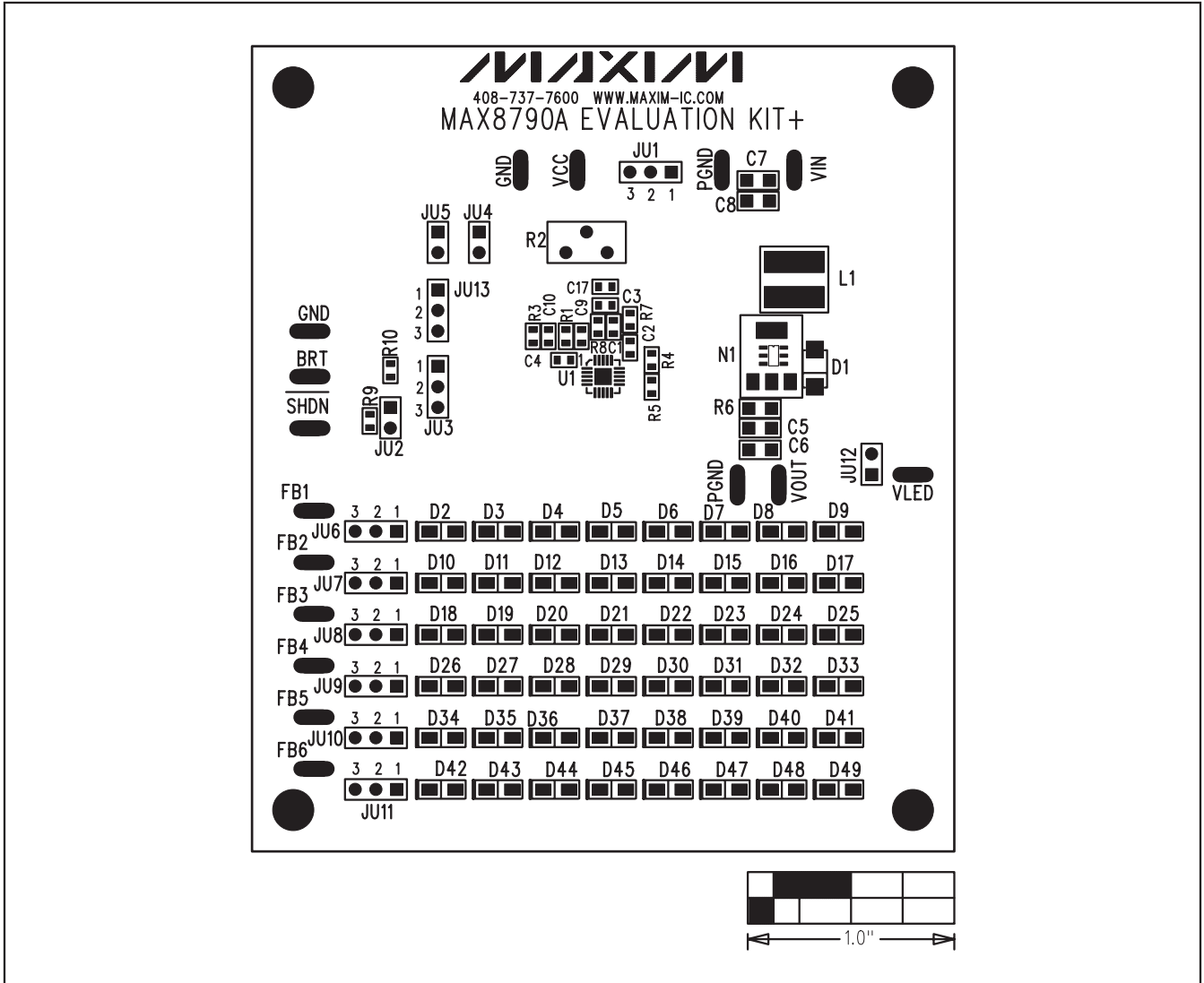

Figure 2. MAX8790A EV Kit Component Placement Guide—Component Side



# MAX8790A Evaluation Kit

Evaluates: MAX8790A

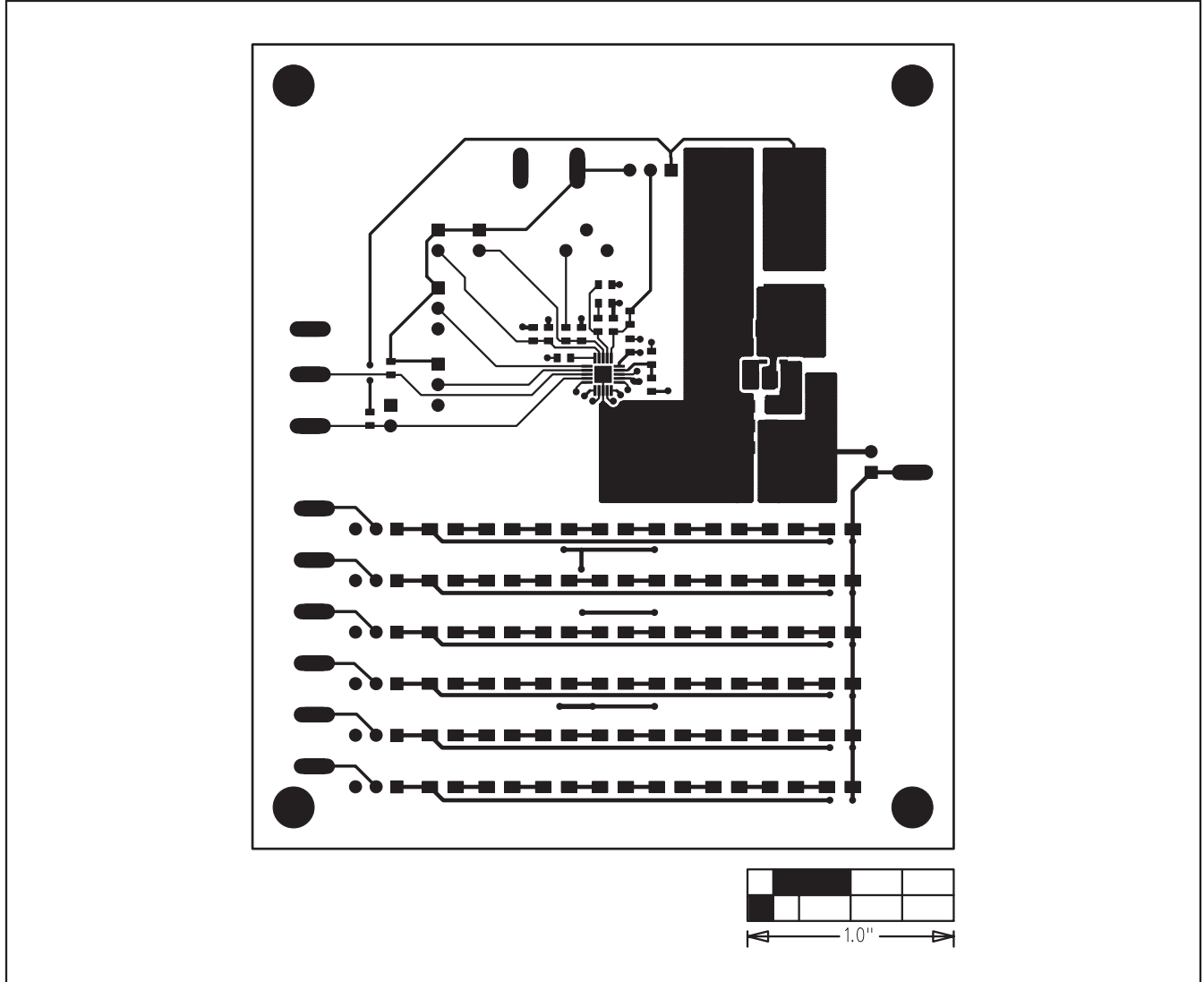

Figure 3. MAX8790A EV Kit PCB Layout—Component Side

# MAX8790A Evaluation Kit

Evaluates: MAX8790A

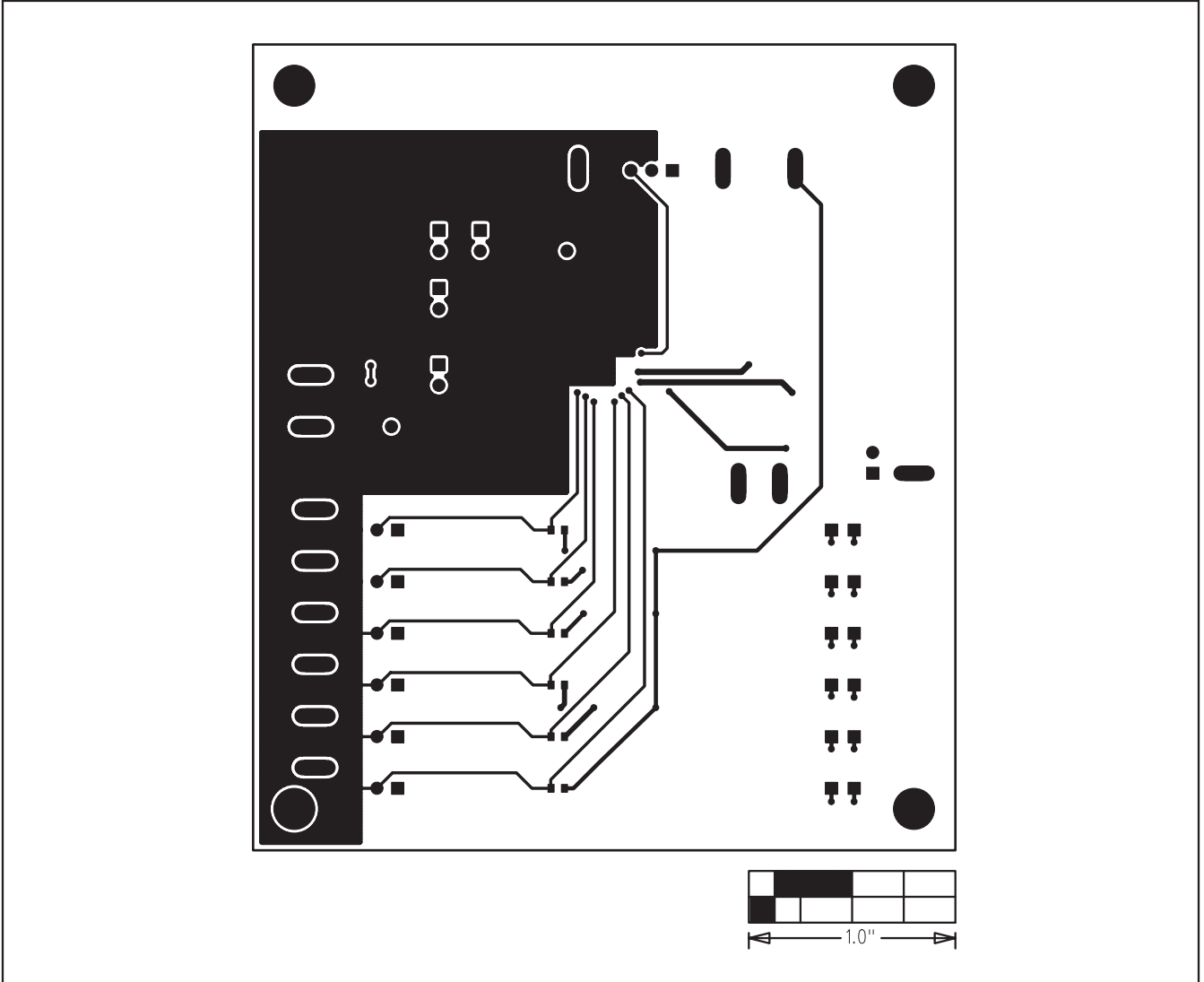

Figure 4. MAX8790A EV Kit PCB Layout—Solder Side

# MAX8790A Evaluation Kit

Evaluates: MAX8790A

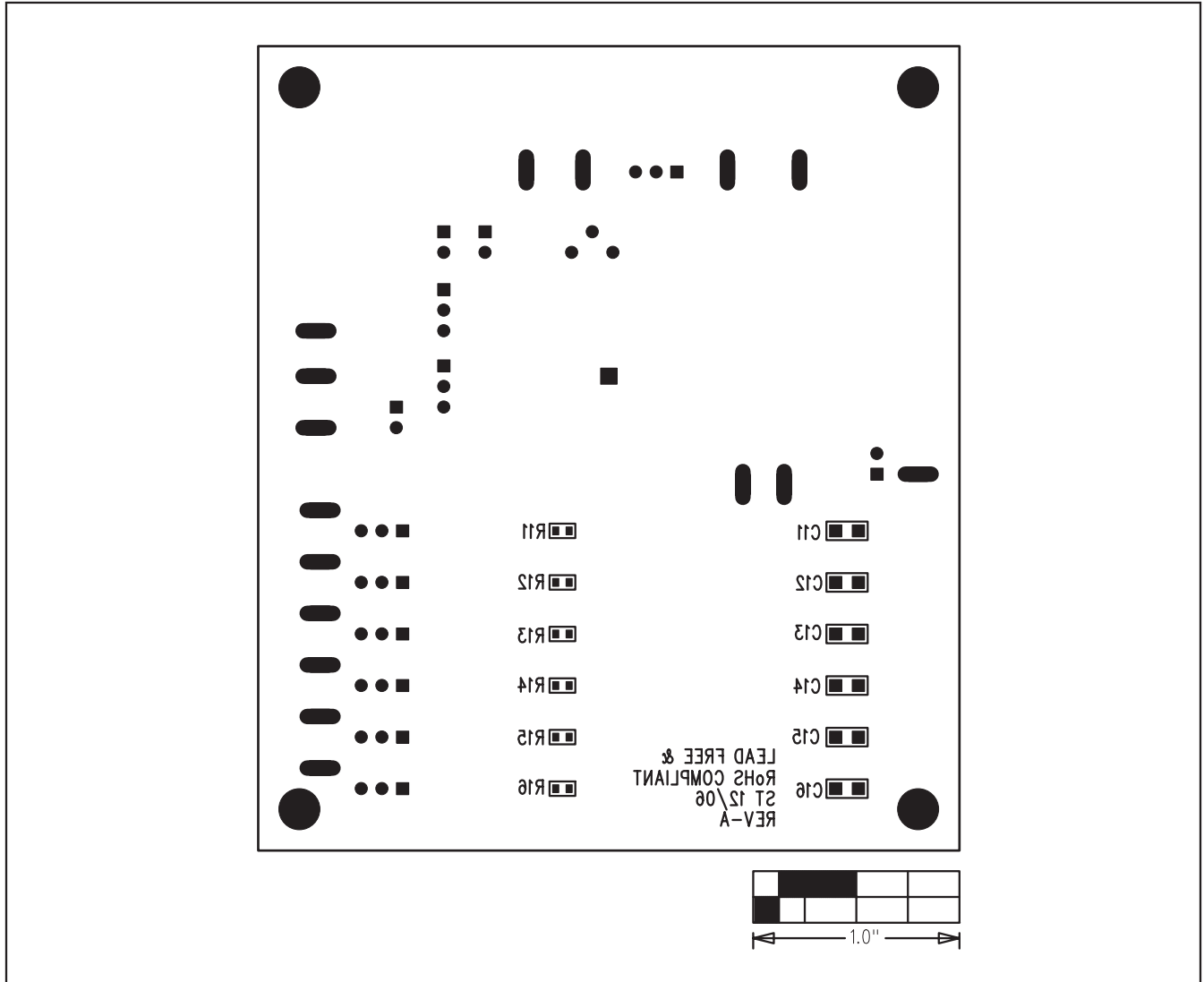

Figure 5. MAX8790A EV Kit Component Placement Guide—Solder Side

# MAX8790A Evaluation Kit

## Revision History

REVISION NUMBER	REVISION DATE	DESCRIPTION	PAGES CHANGED
0	3/07	Initial release	—
1	3/08	IC changed from MAX8790 to MAX8790A.	All pages

**Evaluates: MAX8790A**

Maxim cannot assume responsibility for use of any circuitry other than circuitry entirely embodied in a Maxim product. No circuit patent licenses are implied. Maxim reserves the right to change the circuitry and specifications without notice at any time.

**Maxim Integrated Products, 120 San Gabriel Drive, Sunnyvale, CA 94086 408-737-7600** \_\_\_\_\_ 11