



Chipsmall Limited consists of a professional team with an average of over 10 year of expertise in the distribution of electronic components. Based in Hongkong, we have already established firm and mutual-benefit business relationships with customers from,Europe,America and south Asia,supplying obsolete and hard-to-find components to meet their specific needs.

With the principle of “Quality Parts,Customers Priority,Honest Operation,and Considerate Service”,our business mainly focus on the distribution of electronic components. Line cards we deal with include Microchip,ALPS,ROHM,Xilinx,Pulse,ON,Everlight and Freescale. Main products comprise IC,Modules,Potentiometer,IC Socket,Relay,Connector.Our parts cover such applications as commercial,industrial, and automotives areas.

We are looking forward to setting up business relationship with you and hope to provide you with the best service and solution. Let us make a better world for our industry!



## Contact us

Tel: +86-755-8981 8866 Fax: +86-755-8427 6832

Email & Skype: info@chipsmall.com Web: www.chipsmall.com

Address: A1208, Overseas Decoration Building, #122 Zhenhua RD., Futian, Shenzhen, China



# Standard-Definition Video Filter Amplifiers with Dual SPST Switches

## General Description

The MAX9517/MAX9524 are low-power video amplifiers with integrated reconstruction filters. Specially suited for standard-definition video signals, such as composite and luma, these devices are ideal for a wide range of applications such as cell phones and security/CCTV cameras. Video signals should be DC-coupled into the MAX9517 input and AC-coupled into the MAX9524 input.

The MAX9517/MAX9524 have two single-pole, single-throw (SPST) analog switches that can be used to route stereo audio, video, or digital signals. The reconstruction filter typically has  $\pm 1$ dB passband flatness at 9MHz and 52dB attenuation at 27MHz. The amplifiers have a gain of 2V/V, and the outputs can be DC-coupled to a load of 75 $\Omega$ , which is equivalent to two video loads. The outputs can be AC-coupled to a load of 150 $\Omega$ , which is equivalent to one video load.

The MAX9517/MAX9524 operate from a 2.7V to 3.6V single supply and are specified over the -40°C to +125°C automotive temperature range. The MAX9517/MAX9524 are available in a small 12-pin TQFN (3mm x 3mm) package.

## Features

- ◆ Integrated Reconstruction Filter for Standard-Definition Video
- ◆ 9MHz,  $\pm 1$ dB Passband
- ◆ 52dB Attenuation at 27MHz
- ◆ Dual SPST Switches
- ◆ Fixed Gain of 2V/V
- ◆ DC- or AC-Coupled Output
- ◆ 2.7V to 3.6V Single-Supply Operation

## Applications

Security/CCTV Cameras  
Mobile Phones/Cell Phones  
Digital Still Cameras (DSC)  
Camcorders (DVC)  
Portable Media Players (PMP)

## Ordering Information

PART	INPUT TYPE	PIN-PACKAGE	PKG CODE	TOP MARK
MAX9517ATC+	DC BIAS	12 TQFN-EP*	T1233+4	ABF
MAX9524ATC+	AC CLAMP	12 TQFN-EP*	T1233+4	ABE

**Note:** All devices are specified over the -40°C to +125°C operating temperature range.

+Denotes a lead-free package.

\*EP = Exposed pad.

Pin Configuration appears at end of data sheet.

## Functional Diagrams

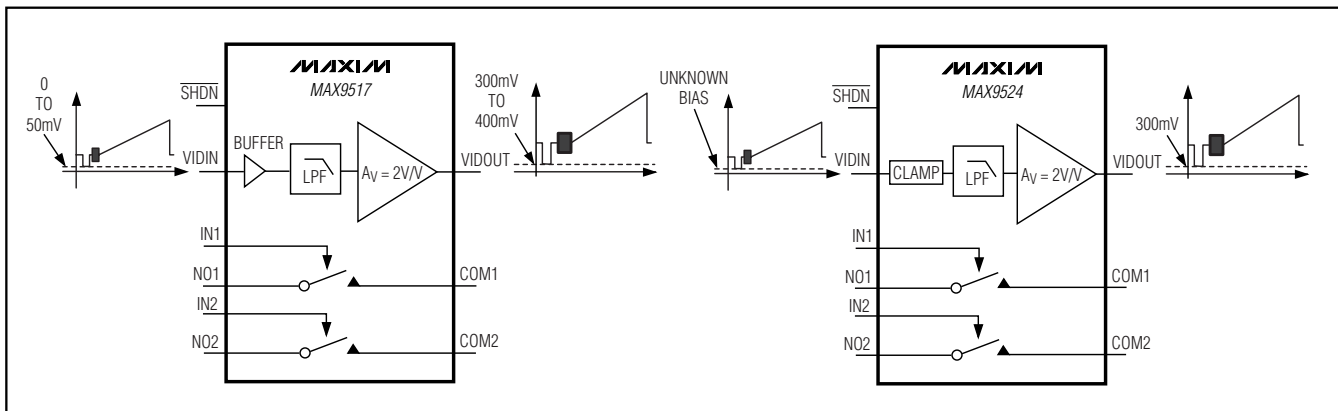

# Standard-Definition Video Filter Amplifiers with Dual SPST Switches

## ABSOLUTE MAXIMUM RATINGS

V <sub>DD</sub> to GND	-0.3V to +4V	Peak Current	
VIDIN to GND	-0.3V to +4V	COM <sub>-</sub> , NO <sub>-</sub> (pulsed at 1ms, 10% duty cycle)	±200mA
COM <sub>-</sub> , NO <sub>-</sub> to GND	-0.3V to (V <sub>DD</sub> + 0.3V)	Continuous Power Dissipation (T <sub>A</sub> = +70°C)	
SHDN, IN <sub>-</sub> to GND	-0.3V to +4V	12-Pin TQFN (derate 14.7mW/°C above +70°C)	1177mW
VIDOUT Short-Circuit Duration to V <sub>DD</sub> , GND	Continuous	Operating Temperature Range	-40°C to +125°C
Continuous Input Current		Junction Temperature	+150°C
VIDIN, IN <sub>-</sub> , SHDN	±20mA	Storage Temperature Range	-65°C to +150°C
COM <sub>-</sub> , NO <sub>-</sub>	±100mA	Lead Temperature (soldering 10s)	+300°C

Stresses beyond those listed under "Absolute Maximum Ratings" may cause permanent damage to the device. These are stress ratings only, and functional operation of the device at these or any other conditions beyond those indicated in the operational sections of the specifications is not implied. Exposure to absolute maximum rating conditions for extended periods may affect device reliability.

## ELECTRICAL CHARACTERISTICS

(V<sub>DD</sub> = SHDN = 3.3V, GND = 0V, no load, T<sub>A</sub> = T<sub>MIN</sub> to T<sub>MAX</sub>, unless otherwise noted. Typical values are at T<sub>A</sub> = +25°C.) (Note 1)

PARAMETER	SYMBOL	CONDITIONS	MIN	TYP	MAX	UNITS	
Supply Voltage Range	V <sub>DD</sub>	Guaranteed by PSRR	2.7		3.6	V	
Supply Current	I <sub>DD</sub>	MAX9517		3.5	7	mA	
		MAX9524		4.25	8		
Shutdown Supply Current	I <sub>SHDN</sub>	V <sub>SHDN</sub> = GND			1	μA	
<b>VIDEO</b>							
<b>DC BUFFER INPUTS (MAX9517)</b>							
Input Voltage Range	V <sub>IN</sub>	Guaranteed by output-voltage swing	V <sub>DD</sub> = 2.7V	0	1.05	V	
			V <sub>DD</sub> = 3V	0	1.2		
Input Current	I <sub>IN</sub>	V <sub>IN</sub> = 0V		3.5	10	μA	
Input Resistance	R <sub>IN</sub>			300		kΩ	
DC Voltage Gain	A <sub>v</sub>	R <sub>L</sub> = 150Ω to GND	V <sub>DD</sub> = 2.7V, 0 ≤ V <sub>IN</sub> ≤ 1.05V	1.95	2.00	2.04	V/V
			V <sub>DD</sub> = 3V, 0 ≤ V <sub>IN</sub> ≤ 1.2V	1.95	2.00	2.04	
Output Level		Measured at V <sub>OUT</sub> , VIDIN = 0.1μF to GND, R <sub>L</sub> = 150Ω to GND	200	300	410	mV	
Output-Voltage Swing			Measured at output, V <sub>DD</sub> = 2.7V, 0 ≤ V <sub>IN</sub> ≤ 1.05V, R <sub>L</sub> = 150Ω to -0.2V	2.1		V <sub>P-P</sub>	
			Measured at output, V <sub>DD</sub> = 2.7V, 0 ≤ V <sub>IN</sub> ≤ 1.05V, R <sub>L</sub> = 150Ω to V <sub>DD</sub> /2	2.1			
			Measured at output, V <sub>DD</sub> = 3V, 0 ≤ V <sub>IN</sub> ≤ 1.2V, R <sub>L</sub> = 150Ω to -0.2V	2.4			
			Measured at output, V <sub>DD</sub> = 3V, 0 ≤ V <sub>IN</sub> ≤ 1.2V, R <sub>L</sub> = 150Ω to V <sub>DD</sub> /2	2.4			
			Measured at output, V <sub>DD</sub> = 3.135V, 0 ≤ V <sub>IN</sub> ≤ 1.05V, R <sub>L</sub> = 75Ω to -0.2V	2.1			
<b>SYNC-TIP CLAMP INPUT (MAX9524)</b>							
Sync-Tip Clamp Level	V <sub>C LP</sub>	Sync-tip clamp	0.23		0.39	V	
Input Voltage Range			V <sub>DD</sub> = 2.7V to 3.6V		1.05	V <sub>P-P</sub>	
			V <sub>DD</sub> = 3V to 3.6V		1.2		
Sync Crush		Sync-tip clamp, percentage reduction in sync pulse (0.3V <sub>P-P</sub> ), guaranteed by input clamping current measurement			2	%	

# Standard-Definition Video Filter Amplifiers with Dual SPST Switches

## ELECTRICAL CHARACTERISTICS (continued)

( $V_{DD} = \overline{\text{SHDN}} = 3.3\text{V}$ ,  $\text{GND} = 0\text{V}$ , no load,  $T_A = T_{\text{MIN}}$  to  $T_{\text{MAX}}$ , unless otherwise noted. Typical values are at  $T_A = +25^\circ\text{C}$ .) (Note 1)

PARAMETER	SYMBOL	CONDITIONS		MIN	TYP	MAX	UNITS
Input Clamping Current		Sync-tip clamp			1	2	$\mu\text{A}$
Maximum Input Source Resistance					300		$\Omega$
DC Voltage Gain (Note 2)	$A_V$	$R_L = 150\Omega$ to GND	$V_{DD} = 2.7\text{V}$ , $0 \leq V_{IN} \leq 1.05\text{V}$	1.95	2.00	2.04	V/V
			$V_{DD} = 3\text{V}$ , $0 \leq V_{IN} \leq 1.2\text{V}$	1.95	2.00	2.04	
Output Level		Measured at $V_{OUT}$ , $V_{IDIN} = 0.1\mu\text{F}$ to GND, $R_L = 150\Omega$ to GND		0.21	0.30	0.39	V
Output-Voltage Swing		Measured at output, $V_{DD} = 2.7\text{V}$ , $V_{IN} = V_{\text{CLP}}$ to $(V_{\text{CLP}} + 1.05\text{V})$ , $R_L = 150\Omega$ to $-0.2\text{V}$		2.1		V <sub>P-P</sub>	
		Measured at output, $V_{DD} = 2.7\text{V}$ , $V_{IN} = V_{\text{CLP}}$ to $(V_{\text{CLP}} + 1.05\text{V})$ , $R_L = 150\Omega$ to $V_{DD}/2$		2.1			
		Measured at output, $V_{DD} = 3\text{V}$ , $V_{IN} = V_{\text{CLP}}$ to $(V_{\text{CLP}} + 1.2\text{V})$ , $R_L = 150\Omega$ to $-0.2\text{V}$		2.4			
		Measured at output, $V_{DD} = 3\text{V}$ , $V_{IN} = V_{\text{CLP}}$ to $(V_{\text{CLP}} + 1.2\text{V})$ , $R_L = 150\Omega$ to $V_{DD}/2$		2.4			
		Measured at output, $V_{DD} = 3.135\text{V}$ , $V_{IN} = V_{\text{CLP}}$ to $(V_{\text{CLP}} + 1.05\text{V})$ , $R_L = 75\Omega$ to $-0.2\text{V}$		2.1			
Output Short-Circuit Current		Short to GND (sourcing)		140		mA	
		Short to $V_{CC}$ (sinking)		70			
Output Resistance	$R_{OUT}$	$V_{OUT} = 1.5\text{V}$ , $-10\text{mA} \leq I_{LOAD} \leq +10\text{mA}$		0.2		$\Omega$	
Output Leakage Current		$\overline{\text{SHDN}} = \text{GND}$		1		$\mu\text{A}$	
Power-Supply Rejection Ratio		$2.7\text{V} \leq V_{DD} \leq 3.6\text{V}$		48		dB	
Standard-Definition Reconstruction Filter		$\pm 1\text{dB}$ passband flatness		9		MHz	
		$V_{\text{VIDOUT}} = 2V_{\text{P-P}}$ , reference frequency is 100kHz	$f = 5.5\text{MHz}$	+0.15			
			$f = 10\text{MHz}$	-3			
			$f = 27\text{MHz}$	-52			
Differential Gain	DG	5-step modulated staircase of 129mV step size and 286mV <sub>P-P</sub> subcarrier amplitude; $f = 4.43\text{MHz}$		1		%	
Differential Phase	DP	5-step modulated staircase of 129mV step size and 286mV <sub>P-P</sub> subcarrier amplitude; $f = 4.43\text{MHz}$		0.4		Degrees	
2T Pulse-to-Bar K Rating		Bar time is 18 $\mu\text{s}$ , the beginning 2.5% and the ending 2.5% of the bar time are ignored, $2T = 200\text{ns}$		0.6		K%	
2T Pulse Response		$2T = 200\text{ns}$		0.2		K%	
2T Bar Response		Bar time is 18 $\mu\text{s}$ , the beginning 2.5% and the ending 2.5% of the bar time are ignored, $2T = 200\text{ns}$		0.2		K%	



# Standard-Definition Video Filter Amplifiers with Dual SPST Switches

## ELECTRICAL CHARACTERISTICS (continued)

( $V_{DD} = \text{SHDN} = 3.3\text{V}$ ,  $\text{GND} = 0\text{V}$ , no load,  $T_A = T_{\text{MIN}}$  to  $T_{\text{MAX}}$ , unless otherwise noted. Typical values are at  $T_A = +25^\circ\text{C}$ .) (Note 1)

PARAMETER	SYMBOL	CONDITIONS	MIN	TYP	MAX	UNITS
Nonlinearity		5-step staircase, $f = 4.43\text{MHz}$		0.5		%
Group Delay Distortion		$100\text{kHz} \leq f \leq 5.5\text{MHz}$ , outputs are $2V_{P-P}$		12		ns
Peak Signal to RMS Noise		$100\text{kHz} \leq f \leq 5.5\text{MHz}$		71		dB
Power-Supply Rejection Ratio		$f = 1\text{MHz}$ , $100\text{mV}_{P-P}$		29		dB
Output Impedance		$f = 5.5\text{MHz}$		4.8		$\Omega$
All-Hostile Crosstalk		$f = 4.43\text{MHz}$		-64		dB
<b>ANALOG SWITCHES</b>						
Analog Signal Range	$V_{\text{COM}_-}$ , $V_{\text{NO}_-}$		0		$V_{DD}$	V
On-Resistance (Note 3)	$R_{\text{ON}}$	$V_{DD} = 2.7\text{V}$ , $I_{\text{COM}_-} = 10\text{mA}$ , $V_{\text{NO}_-} = 1.5\text{V}$		1.7	5.0	$\Omega$
On-Resistance Match Between Channels (Notes 3, 4)	$\Delta R_{\text{ON}}$	$V_{DD} = 2.7\text{V}$ , $I_{\text{COM}_-} = 10\text{mA}$ , $V_{\text{NO}_-} = 1.5\text{V}$			0.4	$\Omega$
On-Resistance Flatness (Note 5)	$R_{\text{FLAT(ON)}}$	$V_{DD} = 2.7\text{V}$ , $I_{\text{COM}_-} = 10\text{mA}$ , $V_{\text{NO}_-} = 1.0\text{V}$ , $1.5\text{V}$ , $2.0\text{V}$		0.5	1.5	$\Omega$
$\text{NO}_-$ Off-Leakage Current (Note 3)	$I_{\text{NO}_-(\text{OFF})}$	$V_{DD} = 3.6\text{V}$ , $V_{\text{COM}_-} = 0.3\text{V}$ , $3.3\text{V}$ ; $V_{\text{NO}_-} = 3.3\text{V}$ , $0.3\text{V}$	-2		+2	nA
$\text{COM}_-$ On-Leakage Current (Note 3)	$I_{\text{COM}_-(\text{ON})}$	$V_{DD} = 3.6\text{V}$ , $V_{\text{COM}_-} = 0.3\text{V}$ , $3.3\text{V}$ ; $V_{\text{NO}_-} = 0.3\text{V}$ , $3.3\text{V}$ , or unconnected	-2.5		+2.5	nA
Turn-On Time	$t_{\text{ON}}$	$V_{\text{NO}_-} = 1.5\text{V}$ ; $R_L = 300\Omega$ , $C_L = 35\text{pF}$ , $V_{\text{IH}} = 1.5\text{V}$ , $V_{\text{IL}} = 0\text{V}$			100	ns
Turn-Off Time	$t_{\text{OFF}}$	$V_{\text{NO}_-} = 1.5\text{V}$ ; $R_L = 300\Omega$ , $C_L = 35\text{pF}$ , $V_{\text{IH}} = 1.5\text{V}$ , $V_{\text{IL}} = 0\text{V}$			100	ns
Skew (Note 3)	$t_{\text{SKEW}}$	$R_S = 39\Omega$ , $C_L = 50\text{pF}$			2	ns
Charge Injection	Q	$V_{\text{GEN}} = 1.5\text{V}$ , $R_{\text{GEN}} = 0\Omega$ , $C_L = 1\text{nF}$		10		pC
Off-Isolation	$V_{\text{ISO}}$	$f = 10\text{MHz}$ ; $V_{\text{NO}_-} = 1V_{P-P}$ ; $R_L = 50\Omega$ , $C_L = 5\text{pF}$		-55		dB
		$f = 1\text{MHz}$ ; $V_{\text{NO}_-} = 1V_{P-P}$ ; $R_L = 50\Omega$ , $C_L = 5\text{pF}$		-80		
On-Channel -3dB Bandwidth	BW	Signal = $0\text{dBm}$ , $R_L = 50\Omega$ , $C_L = 5\text{pF}$		300		MHz
Total Harmonic Distortion	THD	$V_{\text{COM}_-} = 2V_{P-P}$ , $R_L = 600\Omega$		0.03		%
$\text{NO}_-$ Off-Capacitance	$C_{\text{NO}_-(\text{OFF})}$	$f = 1\text{MHz}$		20		pF
Switch On-Capacitance	$C_{(\text{ON})}$	$f = 1\text{MHz}$		50		pF
Switch-to-Switch	$V_{\text{CT}}$	$f = 10\text{MHz}$ ; $V_{\text{NO}_-} = 1V_{P-P}$ , $R_L = 50\Omega$ , $C_L = 5\text{pF}$		-80		dB
		$f = 1\text{MHz}$ ; $V_{\text{NO}_-} = 1V_{P-P}$ , $R_L = 50\Omega$ , $C_L = 5\text{pF}$		-110		
$\text{NO}_-$ -to-VIDOUT		Video circuit is on, switches are open	$f = 10\text{MHz}$ ; $V_{\text{NO}_-} = 1V_{P-P}$		-55	dB
			$f = 1\text{MHz}$ ; $V_{\text{NO}_-} = 1V_{P-P}$		-80	

# Standard-Definition Video Filter Amplifiers with Dual SPST Switches

## ELECTRICAL CHARACTERISTICS (continued)

( $V_{DD} = \overline{\text{SHDN}} = 3.3\text{V}$ ,  $\text{GND} = 0\text{V}$ , no load,  $T_A = T_{\text{MIN}}$  to  $T_{\text{MAX}}$ , unless otherwise noted. Typical values are at  $T_A = +25^\circ\text{C}$ .) (Note 1)

PARAMETER	SYMBOL	CONDITIONS	MIN	TYP	MAX	UNITS
<b>CROSSTALK</b>						
VIDOUT-to-NO_		Video circuit is on, $f = 20\text{kHz}$ , $\text{VIDOUT} = 2\text{V}_{\text{P-P}}$ , $R_L = 50\Omega$ , $C_L = 5\text{pF}$		90		dB
VIDIN-to-COM		Video circuit is shutdown, $f = 20\text{kHz}$ , $0.25\text{V}_{\text{P-P}}$ at VIDIN, $R_L = 600\Omega$		100		dB
VIDOUT-to-COM		Video circuit is on, $f = 20\text{kHz}$ , $\text{VIDOUT} = 2\text{V}_{\text{P-P}}$ , $R_L = 50\Omega$ , $C_L = 5\text{pF}$		90		dB
<b>LOGIC SIGNAL (IN1 AND IN2)</b>						
Logic-Low Threshold	$V_{\text{IL}}$				0.5	V
Logic-High Threshold	$V_{\text{IH}}$		1.4			V
Logic-Input Current	$I_{\text{IN}}$				10	$\mu\text{A}$
<b>LOGIC SIGNAL (SHDN)</b>						
Logic-Low Threshold	$V_{\text{IL}}$				$0.3 \times V_{\text{DD}}$	V
Logic-High Threshold	$V_{\text{IH}}$		$0.7 \times V_{\text{DD}}$			V
Logic-Input Current	$I_{\text{IN}}$				10	$\mu\text{A}$

**Note 1:** All devices are 100% production tested at  $T_A = +25^\circ\text{C}$ . Specifications over temperature limits are guaranteed by design.

**Note 2:** Voltage gain ( $A_V$ ) is a two-point measurement in which the output-voltage swing is divided by the input-voltage swing.

**Note 3:** Guaranteed by design.

**Note 4:**  $\Delta R_{\text{ON}} = R_{\text{ON}(\text{MAX})} - R_{\text{ON}(\text{MIN})}$ .

**Note 5:** Flatness is defined as the difference between the maximum and minimum value of on-resistance as measured over the specified analog signal ranges.

## Typical Operating Characteristics

( $V_{\text{DD}} = \overline{\text{SHDN}} = 3.3\text{V}$ . Video outputs have  $R_L = 150\Omega$  connected to GND.  $T_A = +25^\circ\text{C}$ , unless otherwise noted.)

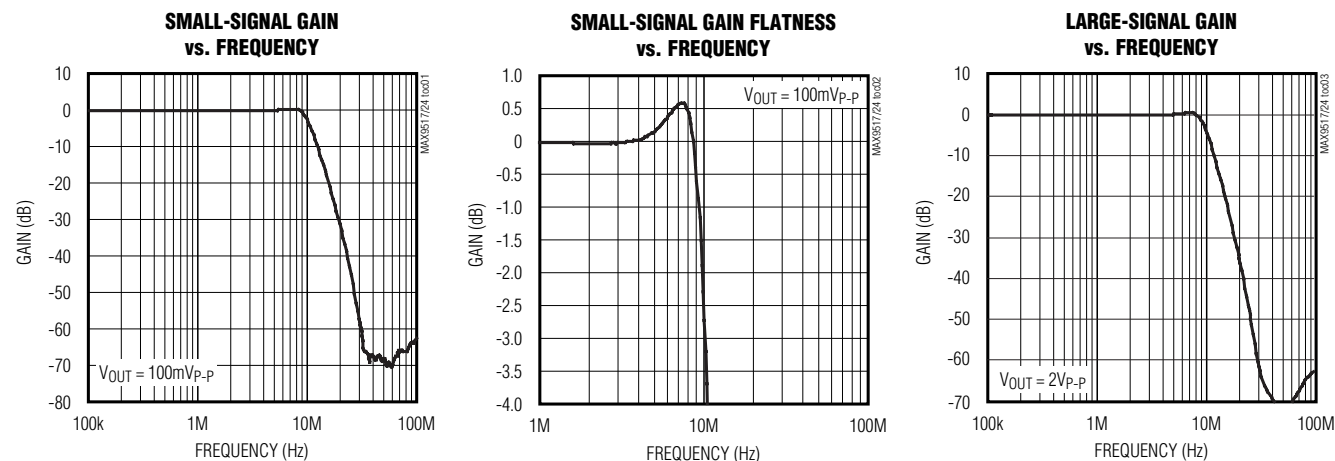

# Standard-Definition Video Filter Amplifiers with Dual SPST Switches

## Typical Operating Characteristics (continued)

( $V_{DD} = \overline{\text{SHDN}} = 3.3\text{V}$ . Video outputs have  $R_L = 150\Omega$  connected to GND.  $T_A = +25^\circ\text{C}$ , unless otherwise noted.)

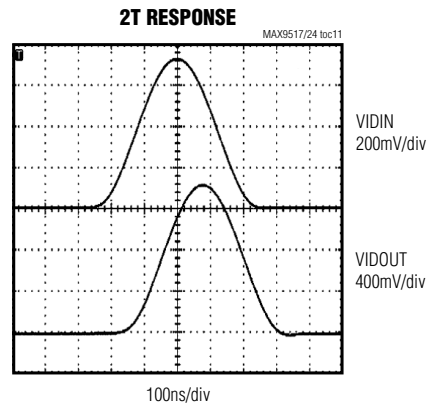
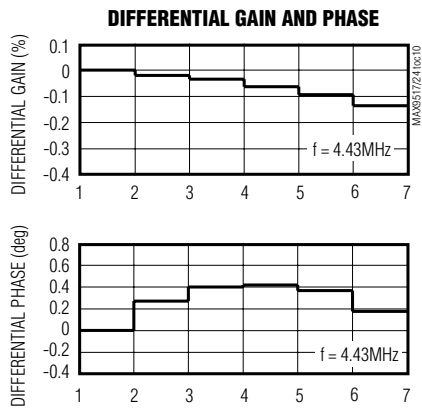
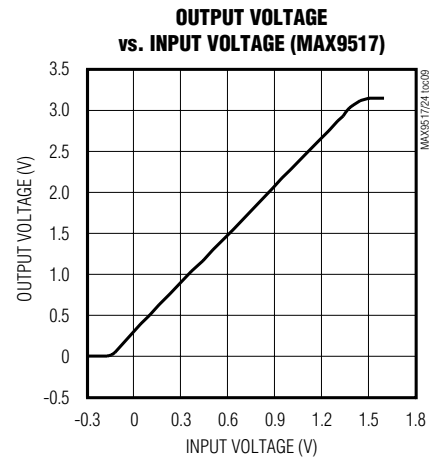
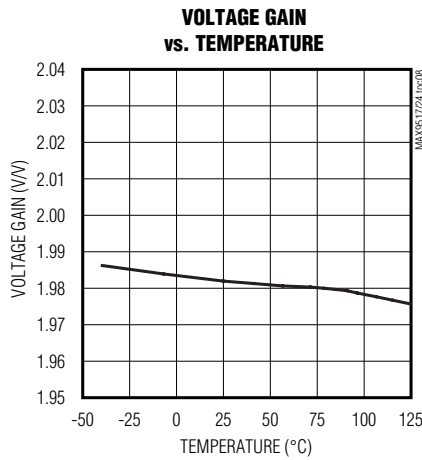
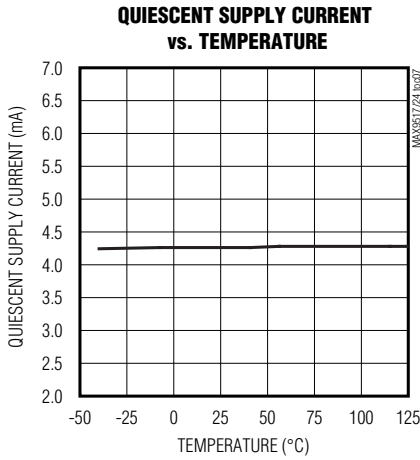
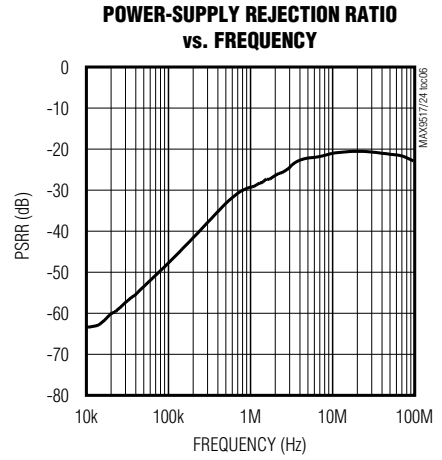
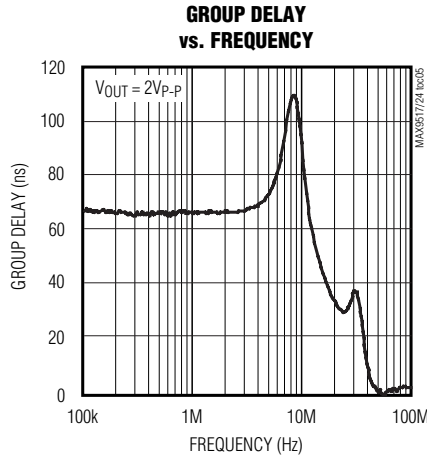
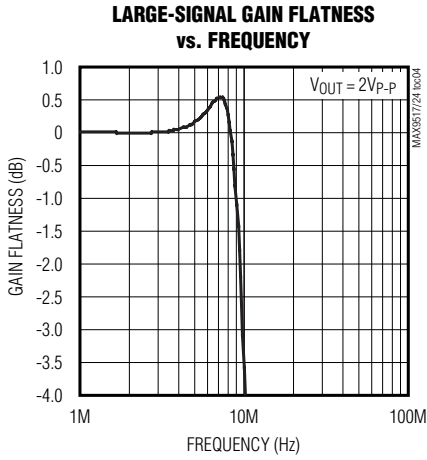

# Standard-Definition Video Filter Amplifiers with Dual SPST Switches

## Typical Operating Characteristics (continued)

( $V_{DD} = \overline{SHDN} = 3.3V$ . Video outputs have  $R_L = 150\Omega$  connected to GND.  $T_A = +25^\circ C$ , unless otherwise noted.)

**12.5T RESPONSE**

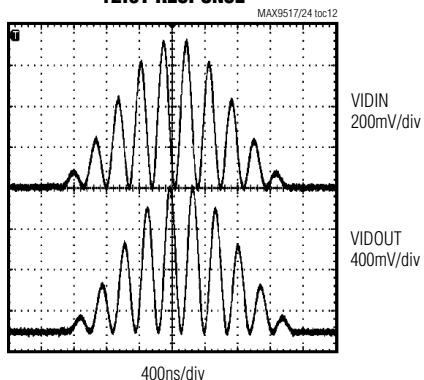

**NTC-7 VIDEO TEST SIGNAL**

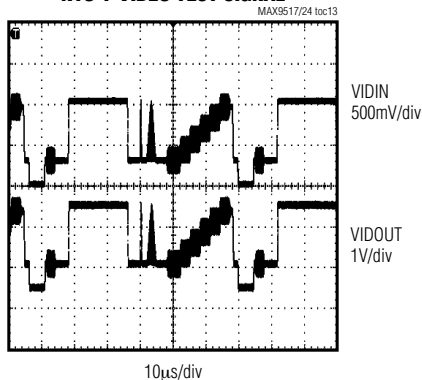

**PAL MULTIBURST RESPONSE**

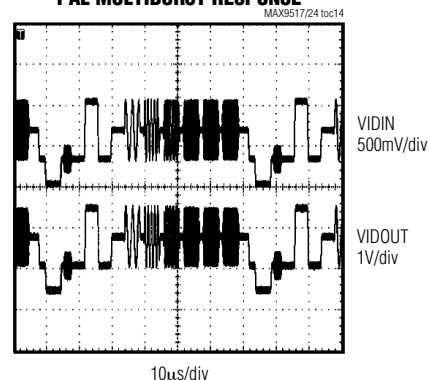

**PAL COLOR BARS**

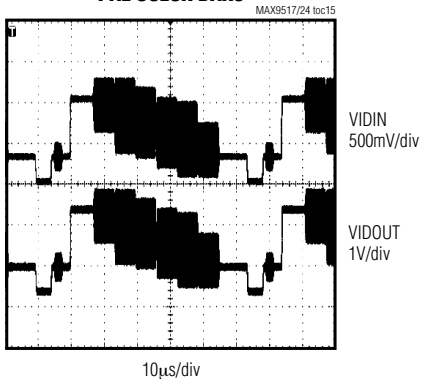

**FIELD SQUARE-WAVE RESPONSE**

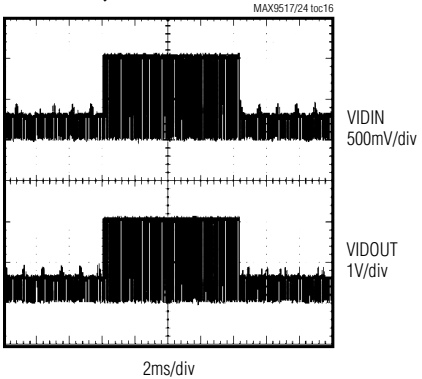

**SWITCH INPUT-TO-INPUT CROSSTALK vs. FREQUENCY**

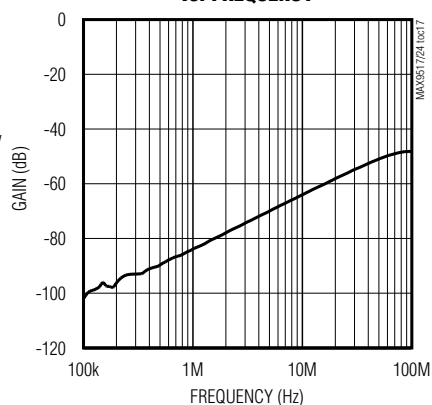

**SWITCH OUTPUT-TO-OUTPUT CROSSTALK vs. FREQUENCY**

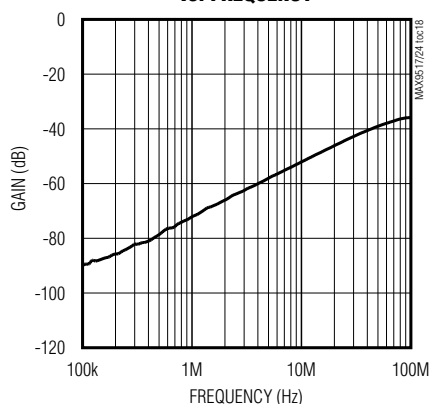

**OUTPUT IMPEDANCE vs. FREQUENCY**

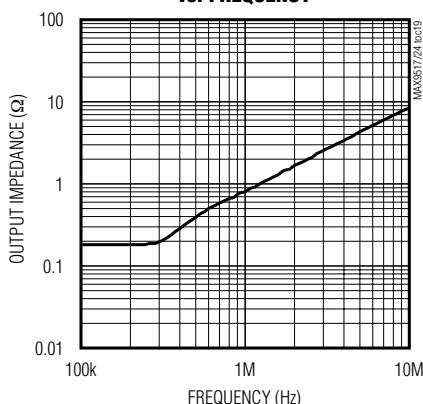



# Standard-Definition Video Filter Amplifiers with Dual SPST Switches

## Typical Operating Characteristics (continued)

( $V_{DD} = \overline{SHDN} = 3.3V$ . Video outputs have  $R_L = 150\Omega$  connected to GND.  $T_A = +25^\circ C$ , unless otherwise noted.)

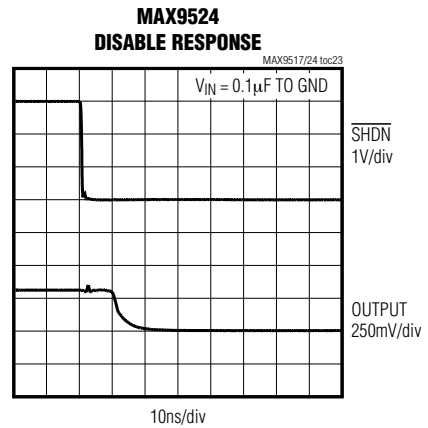
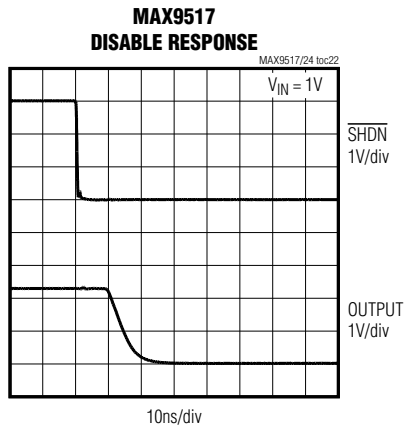
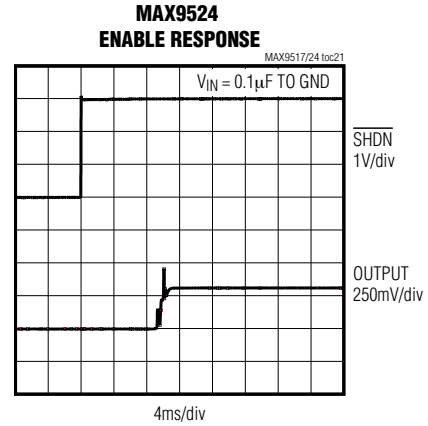
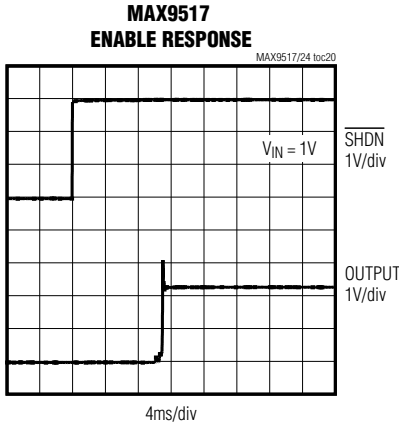

## Pin Description

PIN	NAME	FUNCTION
1	N.C.	No Connection. Not internally connected.
2	COM1	Analog Switch 1 Common Terminal
3	COM2	Analog Switch 2 Common Terminal
4	VIDOUT	Video Output
5	GND	Ground
6	VIDIN	Video Input
7	NO2	Analog Switch 2 Normally Open Terminal
8	NO1	Analog Switch 1 Normally Open Terminal
9	$\overline{SHDN}$	Active-Low Shutdown Input. Connect to GND to place device in shutdown.
10	IN1	Analog Switch 1 Digital Control Input
11	IN2	Analog Switch 2 Digital Control Input
12	$V_{DD}$	Positive Power Supply. Bypass to GND with a 0.1 $\mu F$ capacitor.
—	EP	Exposed Paddle. Connect EP to GND. EP is also internally connected to GND.

# Standard-Definition Video Filter Amplifiers with Dual SPST Switches

## Detailed Description

The MAX9517/MAX9524 consist of a lowpass filter and an output amplifier capable of driving a standard 150 $\Omega$  video load to ground. The MAX9517 has an input buffer and the MAX9524 has an input sync-tip clamp. The MAX9517/MAX9524 both have two SPST analog switches that can be used to route audio, video, or digital signals. The output amplifiers provide a fixed gain of 2V/V.

The MAX9517/MAX9524 filter and amplify the video DAC output. External video signals, in which the DC bias is usually not known, can be AC-coupled to the MAX9524.

### Input with DC Buffer (MAX9517)

The input of the MAX9517 can be directly connected to the video source if the signal is approximately between ground and 1V. This specification is commonly found at the output of most video DACs.

DC-coupling requires that the input signals are ground referenced so that the sync tip of composite or luma signals is within 50mV of ground.

### Input with Sync-Tip Clamp (MAX9524)

When the bias of the incoming video signal is either unknown or not between ground and 1V (such as an external video source), use the MAX9524 to connect the video source through a 0.1 $\mu$ F capacitor.

The VIDIN input of the MAX9524 can only handle signals with a sync pulse, such as composite video and luma. An internal sync-tip clamp sets the internal DC level of the video signal.

### Video Filter

The filter passband ( $\pm 1$ dB) is typically 9MHz to make the device suitable for standard-definition video signals from all sources (including broadcast video and DVD). Broadcast video signals are channel limited: NTSC signals have 4.2MHz bandwidth, and PAL signals have 5MHz bandwidth. Video signals from a DVD player, however, are not channel limited; therefore, the bandwidth of DVD video signals can approach the Nyquist limit of 6.75MHz (recommendation ITU-R BT.601-5 specifies 13.5MHz as the sampling rate for standard-definition video). Therefore, the maximum bandwidth of the signal is 6.75MHz. To ease the filtering requirements, most modern video systems oversample by two times, clocking the video current DAC at 27MHz.

## Outputs

The video output amplifiers can both source and sink load current, allowing output loads to be DC- or AC-coupled. The amplifier output stage needs around 300mV of headroom from either supply rail. The parts have an internal level shift circuit that positions the sync tip at approximately 300mV at the output.

If the supply voltage is greater than 3.135V (5% below a 3.3V supply), each amplifier can drive two DC-coupled video loads to ground. If the supply is less than 3.135V, each amplifier can drive only one DC-coupled or AC-coupled video load.

## Shutdown

The MAX9517/MAX9524 draw less than 1 $\mu$ A supply current when SHDN is low. In shutdown, the amplifier output becomes high impedance.

## SPST Analog Switches

**Table 1. Logic for Analog Switches**

IN_	SWITCH STATE
0	OFF
1	ON

## Applications Information

### Reducing Power Consumption in the Video DACs

The MAX9517/MAX9524 have high-impedance input buffers that can work with source resistances as high as 300 $\Omega$ . To reduce power dissipation in the video DACs, the DAC output resistor can be scaled up in value. The reference resistor that sets the reference current inside the video DACs must also be similarly scaled up. For instance, if the output resistor is 37.5 $\Omega$ , the DAC must source 26.7mA when the output is 1V. If the output resistor is increased to 300 $\Omega$ , the DAC only needs to source 3.33mA when the output is 1V.

There is parasitic capacitance from the DAC output to ground. That capacitance in parallel with the DAC output resistor forms a pole that can potentially roll off the frequency response of the video signal. For example, 300 $\Omega$  in parallel with 50pF creates a pole at 10.6MHz. To minimize this capacitance, reduce the area of the signal trace attached to the DAC output as much as possible, and place the MAX9517/MAX9524 as close as possible to the video DAC outputs.

# Standard-Definition Video Filter Amplifiers with Dual SPST Switches

## AC-Coupling the Outputs

The outputs can be AC-coupled because the output stage can source and sink current as shown in Figure 1. Coupling capacitors should be 220 $\mu$ F or greater to keep the highpass filter formed by the 150 $\Omega$  equivalent resistance of the video transmission line to a corner frequency of 4.8Hz or below. The frame rate of PAL systems is 25Hz, and the frame rate of NTSC systems is 30Hz. The corner frequency should be well below the frame rate.

## Changing Between Video Output and Microphone Input on a Single Connector

A single pole on a mobile phone jack can be used for transmitting a video signal to a television or receiving the signal from the microphone of a headset. Figure 2 shows how the MAX9517 can transmit a video signal. Figure 3 shows how the MAX9517 can receive and pass on the signal from a microphone.

## Switching Between Video and Digital Signals

The dual SPST analog switches and the high-impedance output of the video amplifier enable video transmission, digital transmission, and digital reception all on a single pole of a connector. Figures 4, 5, and 6 show the different configurations of the MAX9517.

## Selecting Between Two Video Sources

The analog switches can multiplex between two video sources. For example, a mobile phone might have an application processor with an integrated video encoder and a mobile graphics processor with an integrated video encoder, each creating a composite video signal that is between 0 and 1V. Figure 7 shows this application

in which the MAX9517 chooses between two internal video sources. The two analog switches can be used as a 2:1 multiplexer to select which video DAC output is actually filtered, amplified, and then driven out to the connector. Close switch 1 to select the video from the application processor. Close switch 2 to select the video from the mobile graphics processor.

Figure 8 shows the application in which the MAX9524 chooses between two external video sources with unknown DC bias.

## Y/C Mixer with Chroma Mute

If the video application processor has two current output digital-to-analog converters (DACs) for luma (Y) and chroma (C), respectively, then the signals can be mixed together to create a composite video signal by summing the currents into a single resistor, as shown in Figure 9. The composite video signal should be AC-coupled into the MAX9524 because the composite video signal has a positive DC level shift. The sync-tip clamp of the MAX9524 will re-establish the DC bias level of the signal inside the chip.

The chroma current is connected to essentially a single-pole, double-throw (SPDT) switch. In one position, the switch routes the chroma current into the resistor. In the other position, the switch routes the chroma current into ground. For the Y/C mixer to work properly, the chroma current must be routed through analog switch 1 into the resistor.

If the chroma signal needs to be muted, then the chroma current is shunted to ground through analog switch 2. Analog switch 1 stays open. See Figure 10.

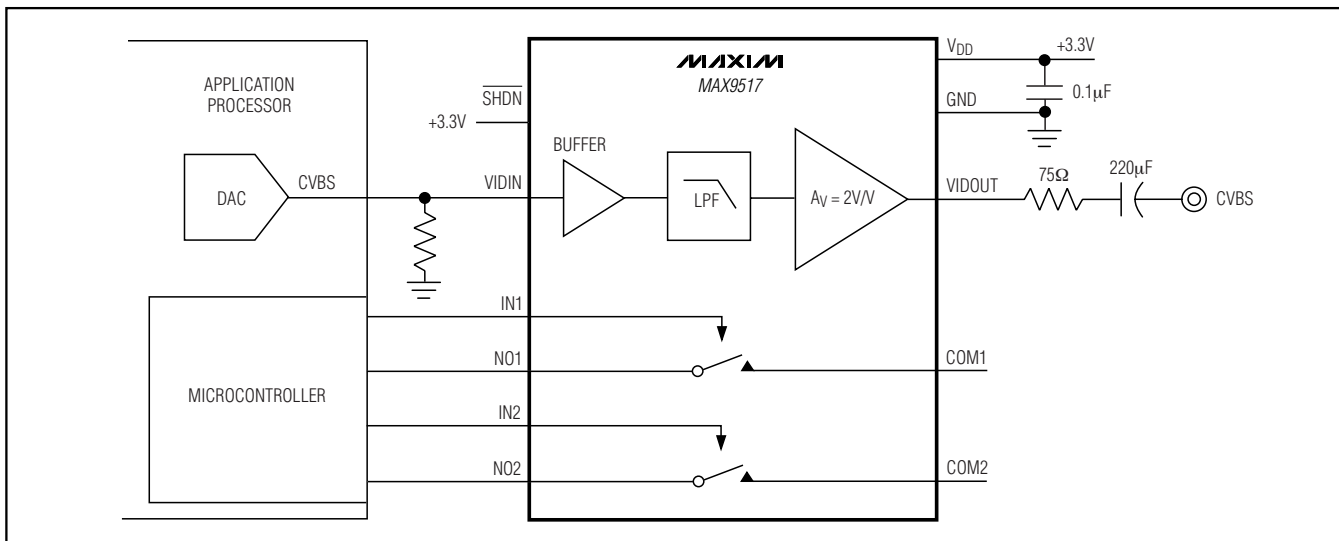

Figure 1. AC-Coupled Outputs

# Standard-Definition Video Filter Amplifiers with Dual SPST Switches

MAX9517/MAX9524

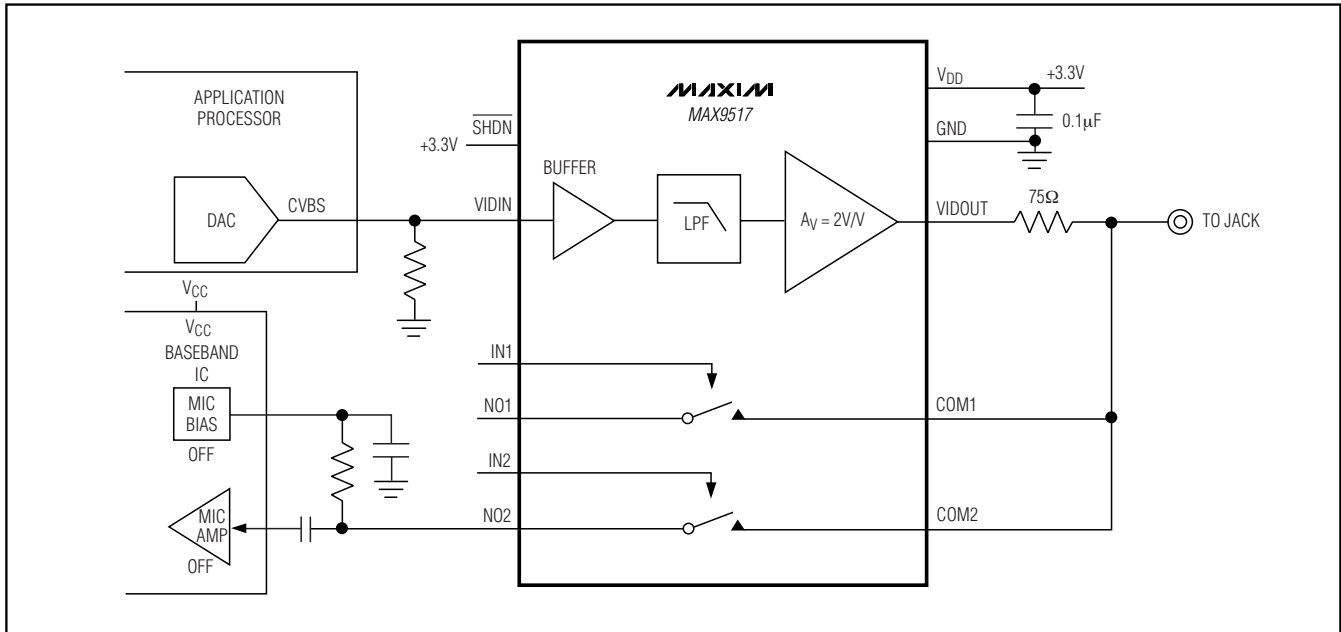

Figure 2. Video Output Configuration

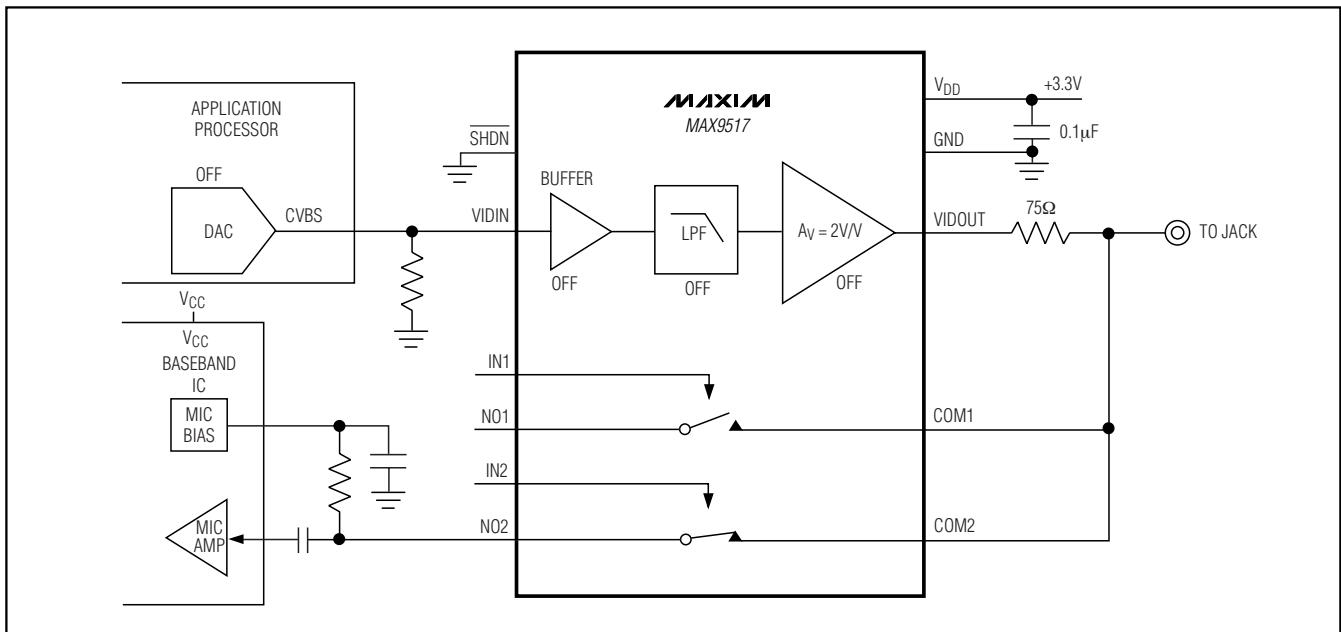

Figure 3. Microphone Input Configuration

# Standard-Definition Video Filter Amplifiers with Dual SPST Switches

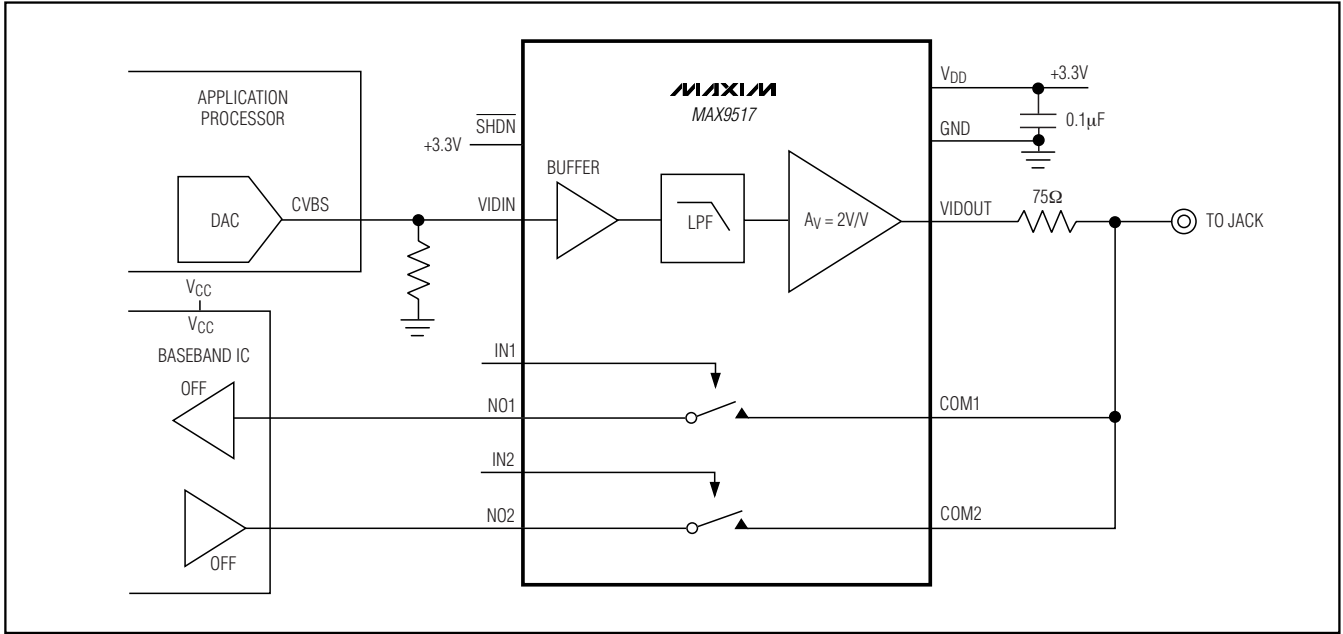

Figure 4. Video Output Configuration

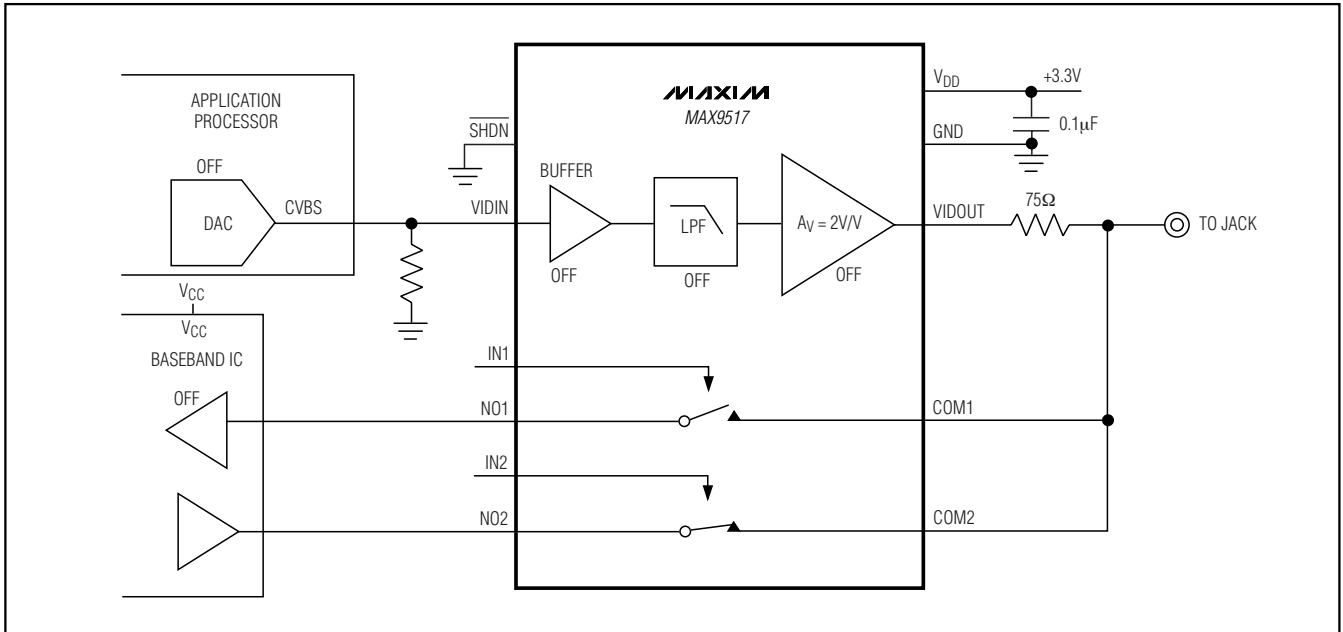

Figure 5. Digital Output Configuration

# Standard-Definition Video Filter Amplifiers with Dual SPST Switches

MAX9517/MAX9524

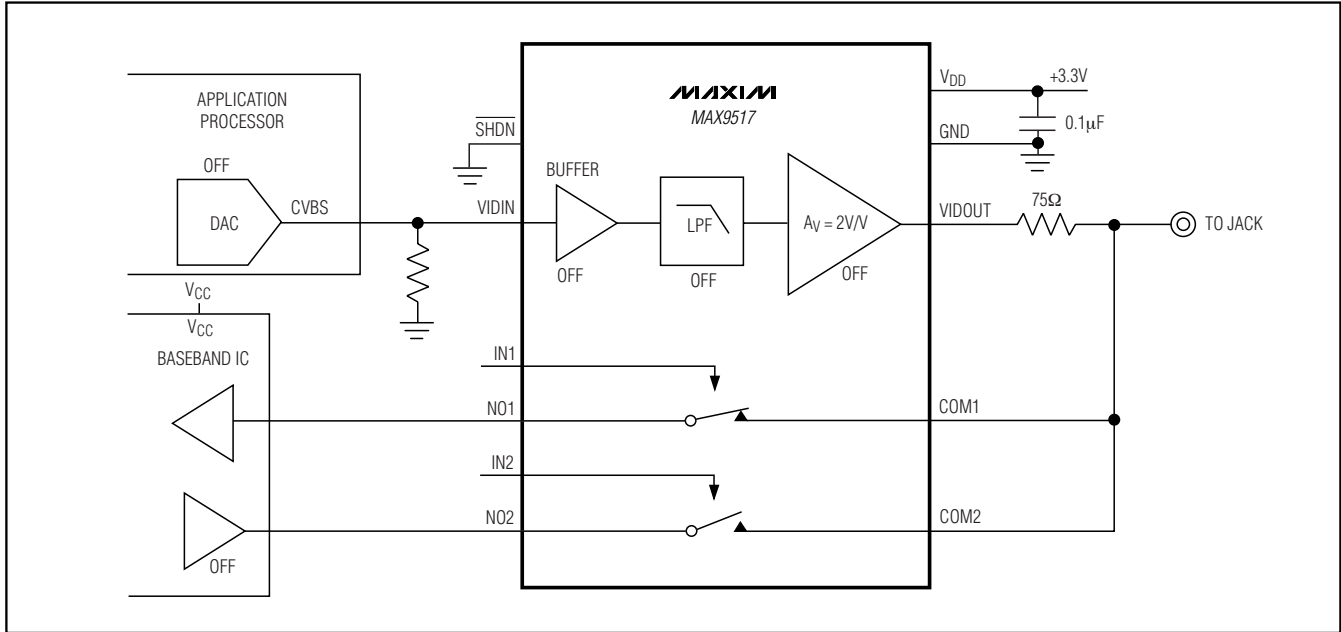

Figure 6. Digital Input Configuration

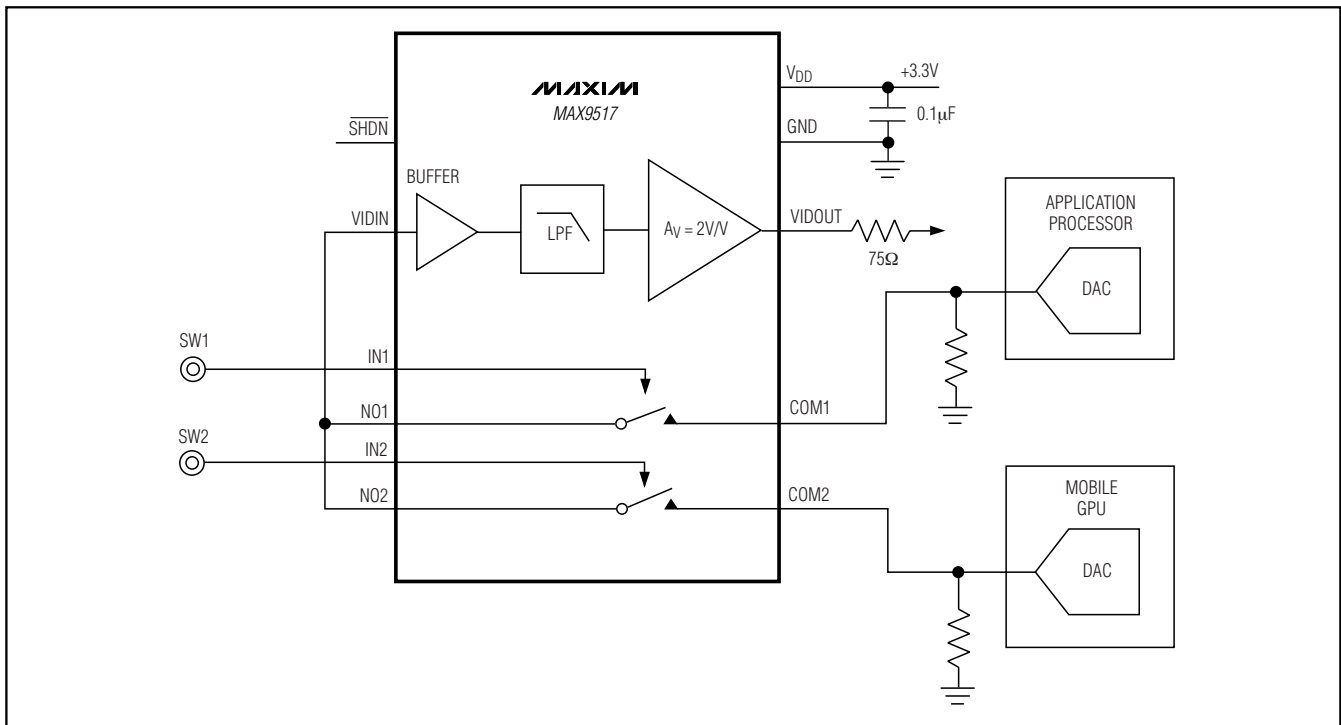

Figure 7. Selecting Between Two Internal Video Sources



# Standard-Definition Video Filter Amplifiers with Dual SPST Switches

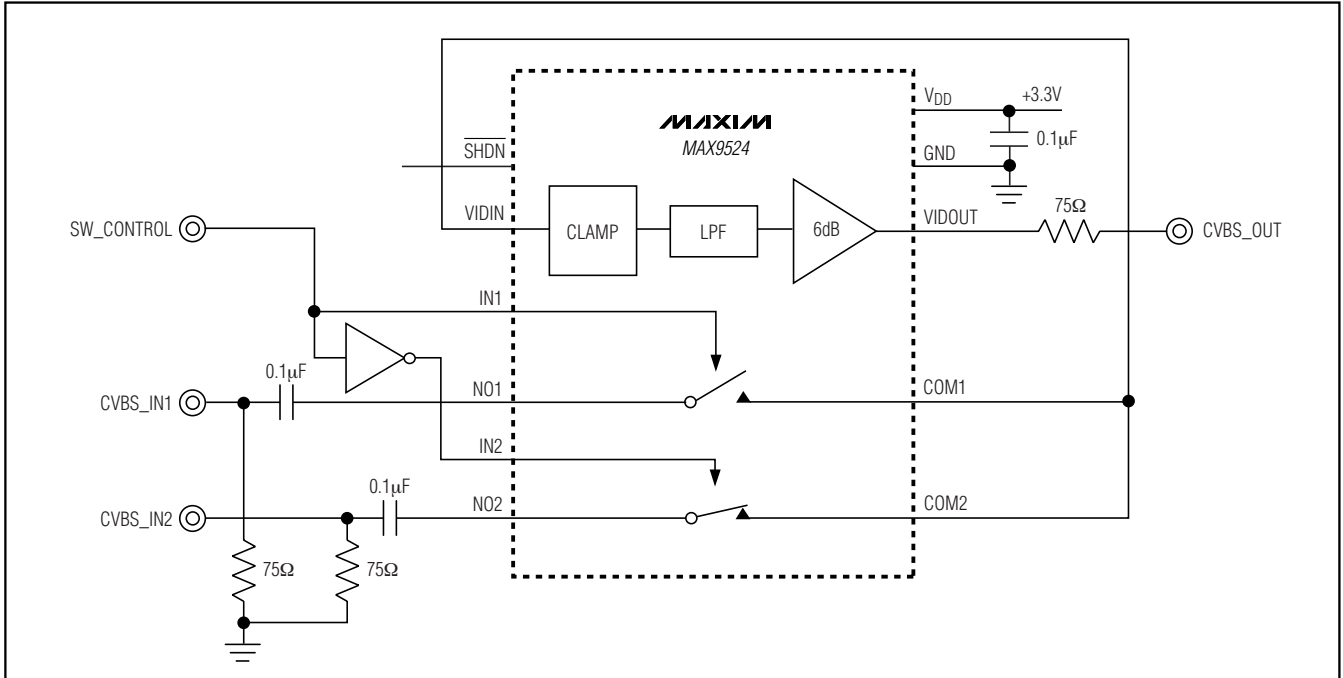

Figure 8. Selecting Between Two External Video Sources

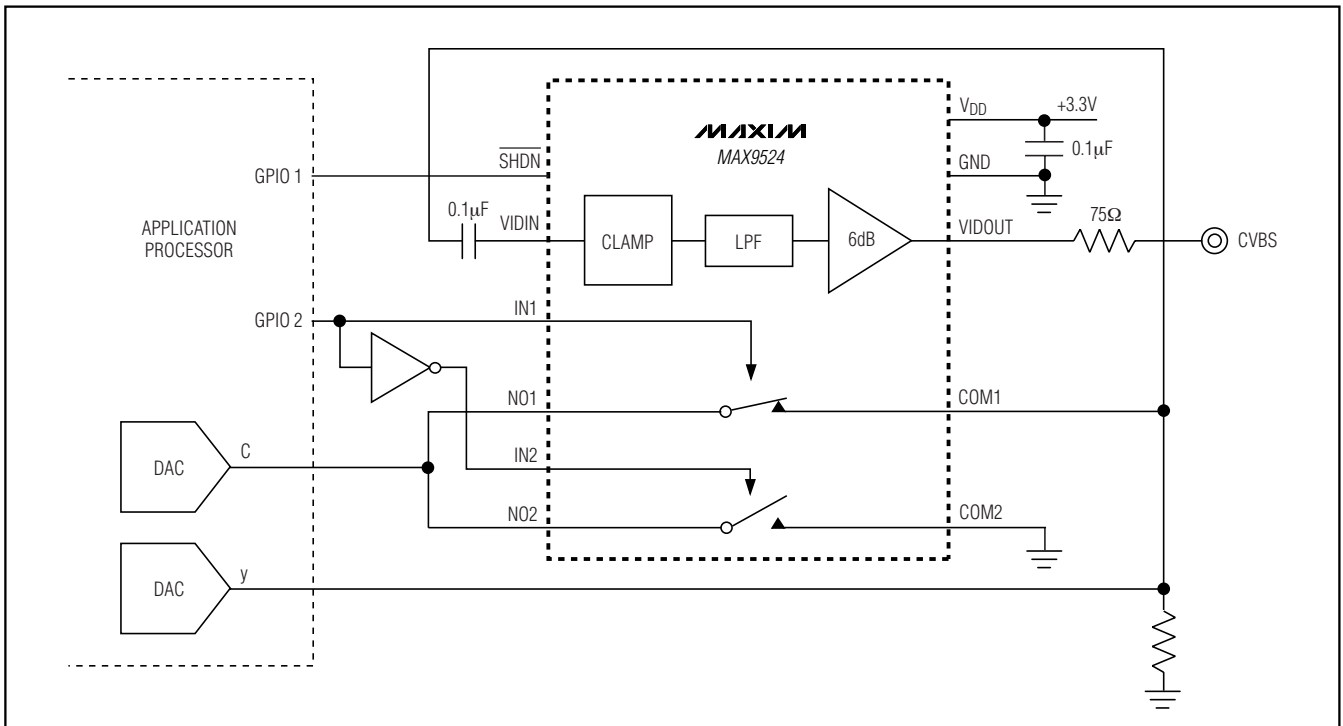

Figure 9. Luma and Chroma Mixer Circuit (Chroma Current Routed into Resistor)

# Standard-Definition Video Filter Amplifiers with Dual SPST Switches

MAX9517/MAX9524

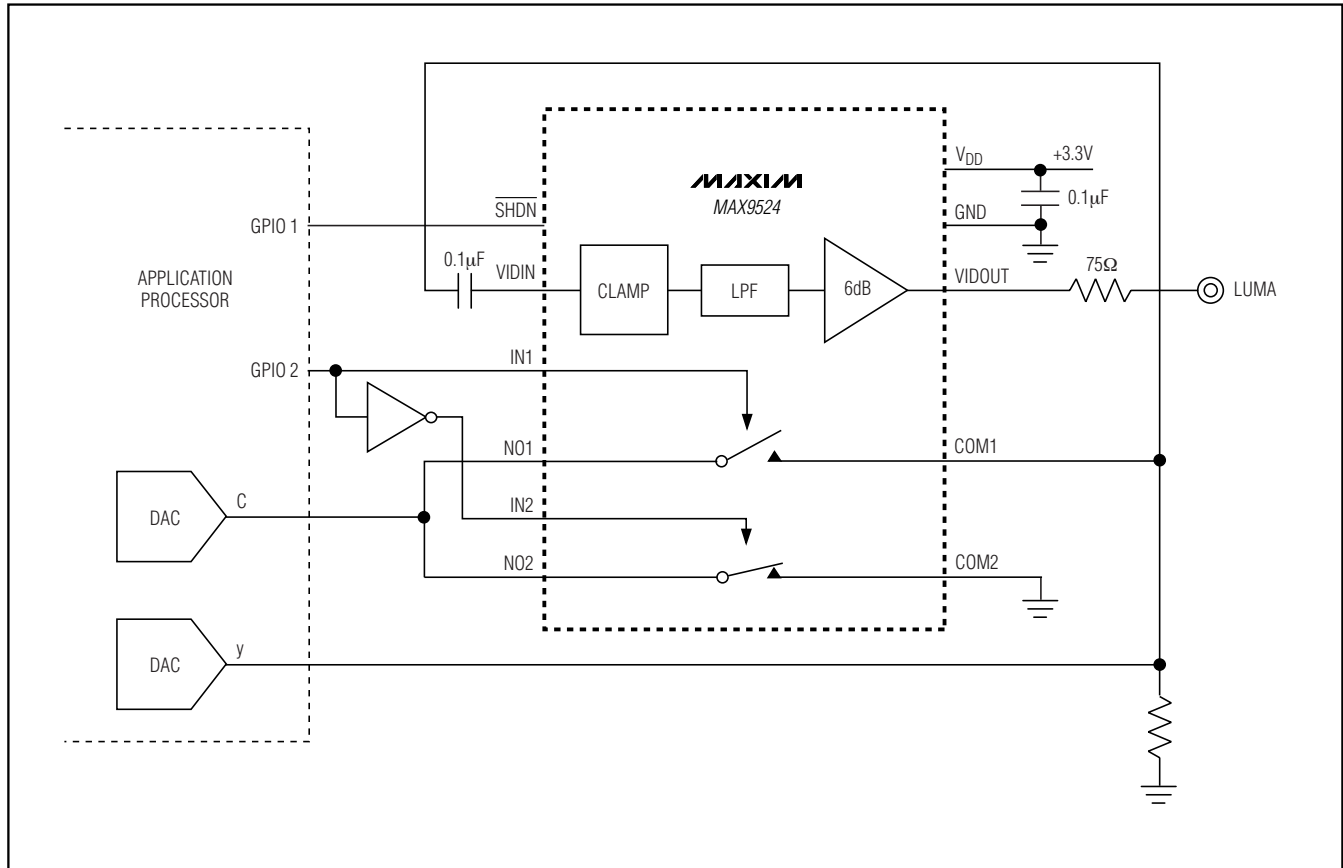

Figure 10. Luma and Chroma Mixer Circuit with Chroma Muted. Chroma Current is Shunted into Ground Through Analog Switch 2.

# Standard-Definition Video Filter Amplifiers with Dual SPST Switches

## Anti-Alias Filter

The MAX9524 can also provide anti-alias filtering with buffer before an analog-to-digital converter (ADC), which would be present in an NTSC/PAL video decoder, for example. Figure 11 shows an example application circuit for MAX9524. An external composite video signal is applied to IN, which is terminated with 75Ω to ground. The signal is AC-coupled to VIDIN because the DC level of an external video signal is usually not well specified.

## Power-Supply Bypassing and Ground

The MAX9517/MAX9524 operate from a single-supply voltage down to 2.7V, allowing for low-power operation. Bypass V<sub>DD</sub> to GND with a 0.1μF capacitor. Place all external components as close as possible to the device.

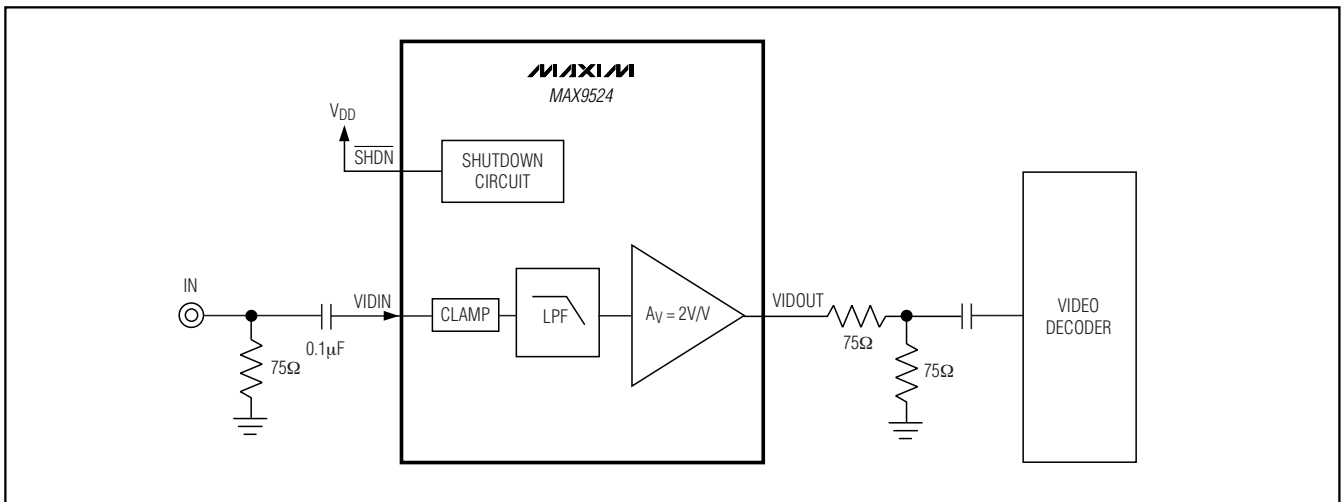

Figure 11. MAX9524 is Used as an Anti-Alias Filter with Buffer (Switches Can Route Other Signals)

## Switch Test Circuits/Timing Diagrams

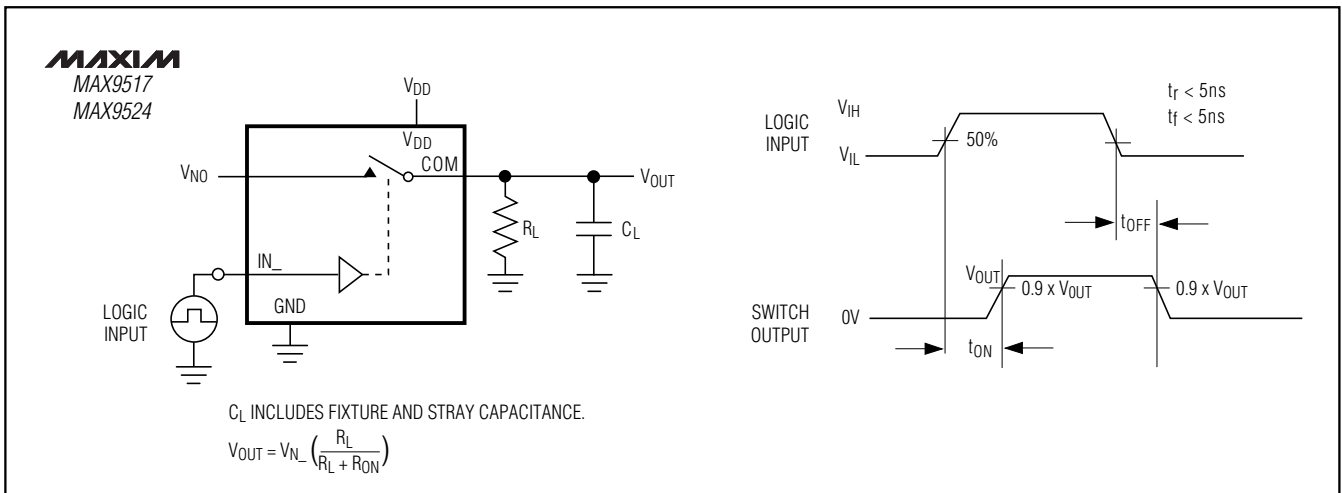

Figure 12. Switching Time

# Standard-Definition Video Filter Amplifiers with Dual SPST Switches

## Switch Test Circuits/Timing Diagrams (continued)

MAX9517/MAX9524

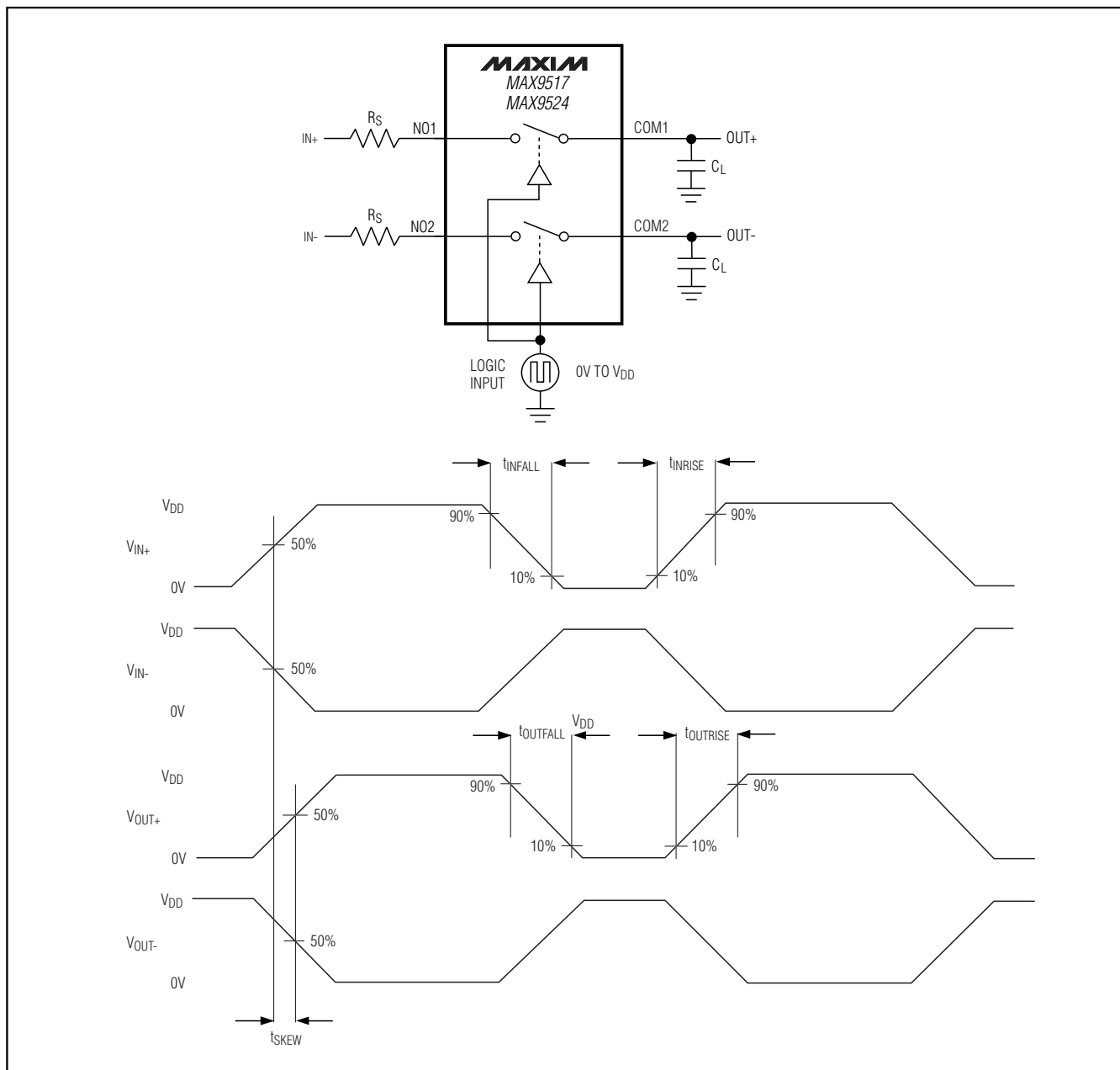

Figure 13. Output Signal Skew

# Standard-Definition Video Filter Amplifiers with Dual SPST Switches

## Switch Test Circuits/Timing Diagrams (continued)

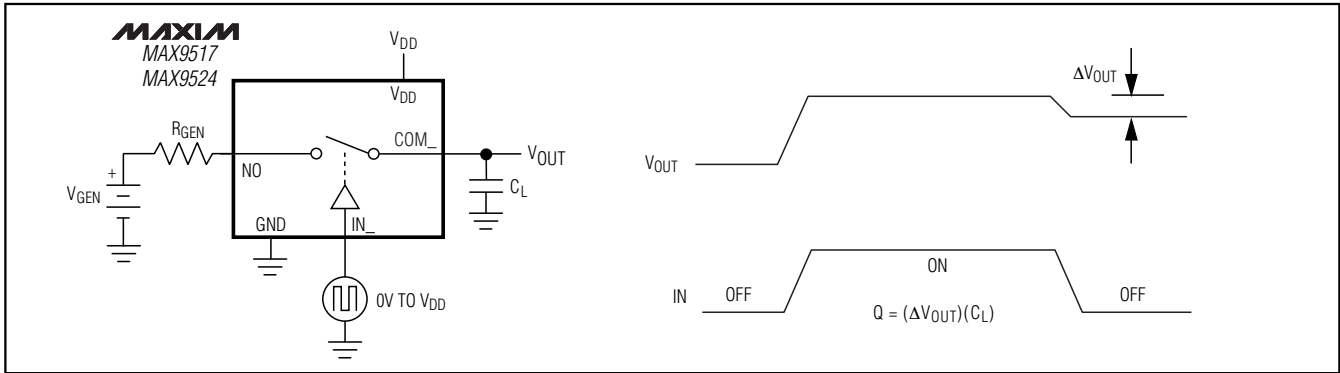

Figure 14. Charge Injection

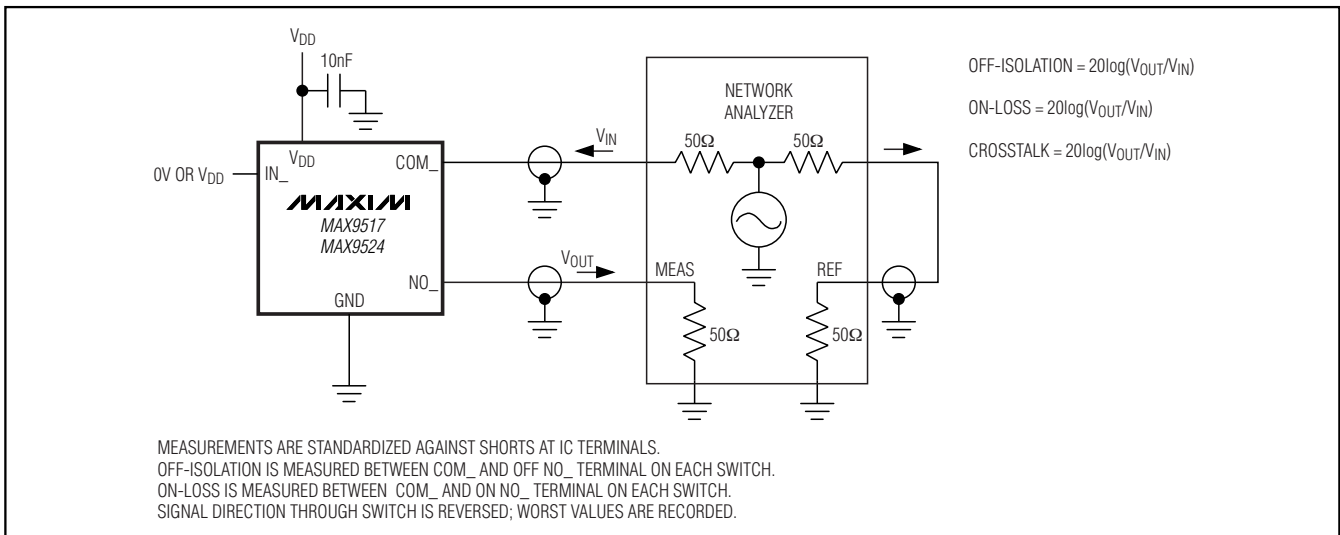

Figure 15. On-Loss, Off-Isolation, and Crosstalk

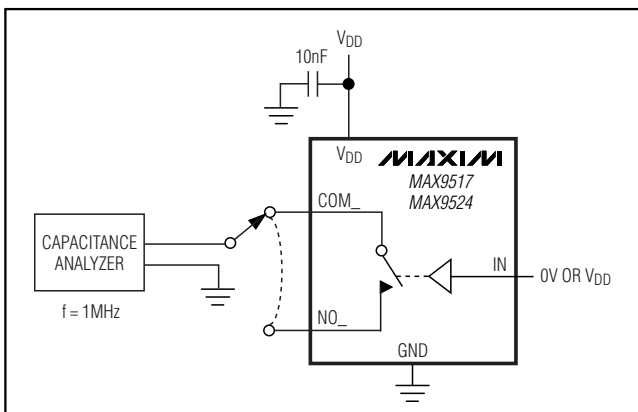
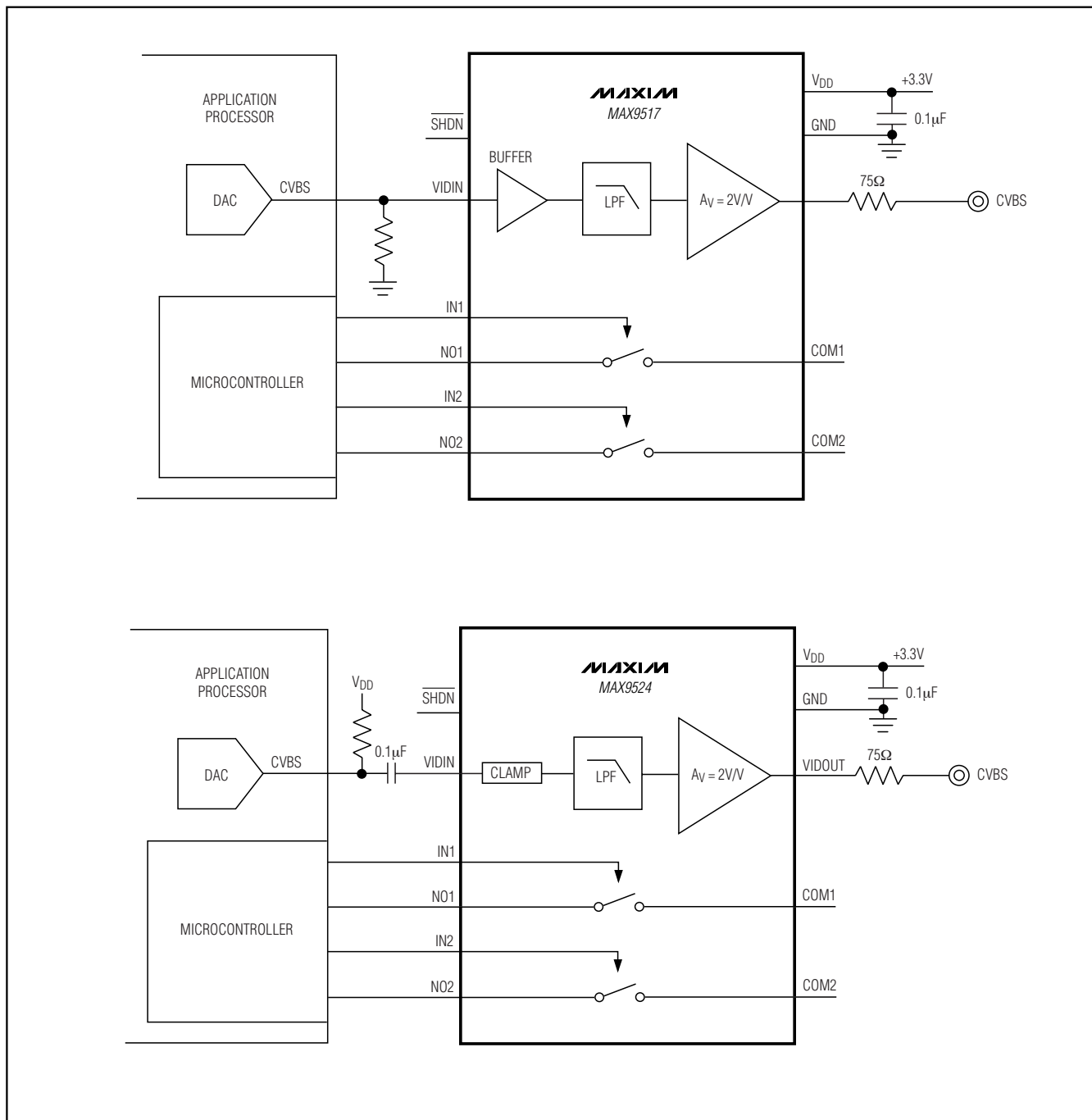

Figure 16. Channel Off-/On-Capacitance

# Standard-Definition Video Filter Amplifiers with Dual SPST Switches

## Typical Operating Circuits

MAX9517/MAX9524





# Standard-Definition Video Filter Amplifiers with Dual SPST Switches

## Pin Configuration

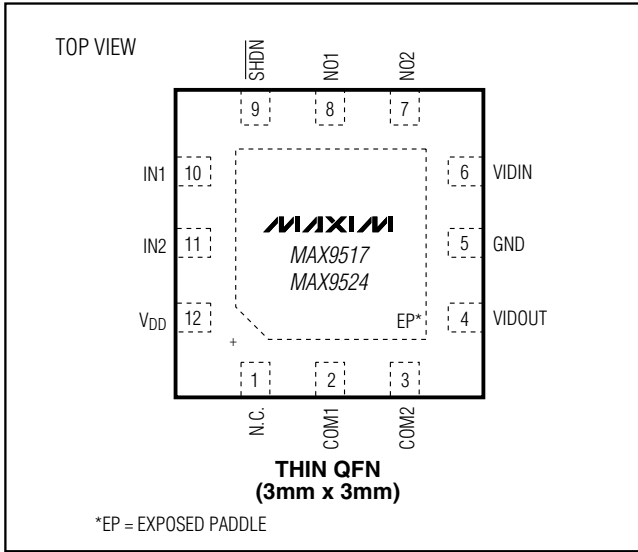

## Chip Information

PROCESS: BiCMOS

# Standard-Definition Video Filter Amplifiers with Dual SPST Switches

## Package Information

(The package drawing(s) in this data sheet may not reflect the most current specifications. For the latest package outline information go to [www.maxim-ic.com/packages](http://www.maxim-ic.com/packages).)

MAX9517/MAX9524

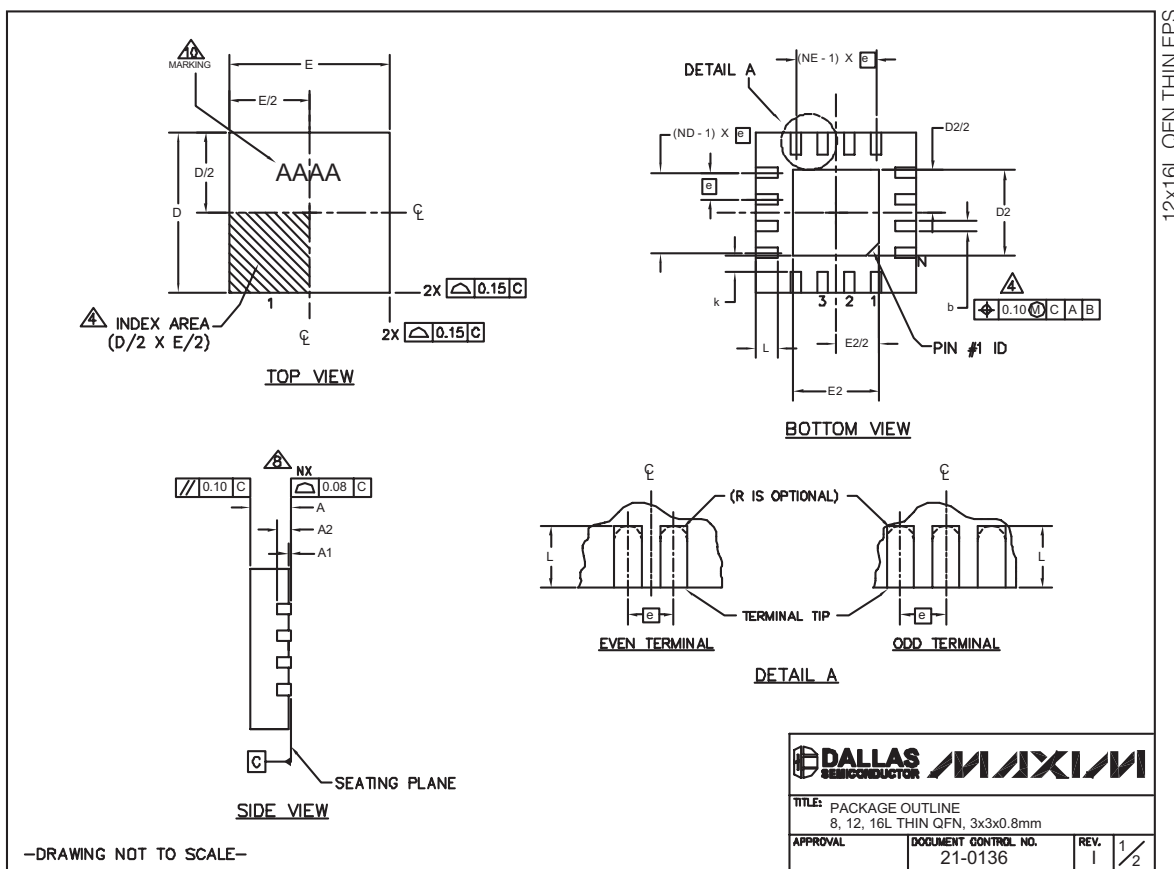

-DRAWING NOT TO SCALE-

<b>DALLAS SEMICONDUCTOR</b>		<b>MAXIM</b>	
TITLE: PACKAGE OUTLINE 8, 12, 16L THIN QFN, 3x3x0.8mm			
APPROVAL	DOCUMENT CONTROL NO. 21-0136	REV. 1	1/2

12x16L QFN THIN.EPS

# Standard-Definition Video Filter Amplifiers with Dual SPST Switches

## Package Information (continued)

(The package drawing(s) in this data sheet may not reflect the most current specifications. For the latest package outline information go to [www.maxim-ic.com/packages](http://www.maxim-ic.com/packages).)

PKG	8L 3x3			12L 3x3			16L 3x3		
REF.	MIN.	NOM.	MAX.	MIN.	NOM.	MAX.	MIN.	NOM.	MAX.
A	0.70	0.75	0.80	0.70	0.75	0.80	0.70	0.75	0.80
b	0.25	0.30	0.35	0.20	0.25	0.30	0.20	0.25	0.30
D	2.90	3.00	3.10	2.90	3.00	3.10	2.90	3.00	3.10
E	2.90	3.00	3.10	2.90	3.00	3.10	2.90	3.00	3.10
e	0.65 BSC.			0.50 BSC.			0.50 BSC.		
L	0.35	0.55	0.75	0.45	0.55	0.65	0.30	0.40	0.50
N	8			12			16		
ND	2			3			4		
NE	2			3			4		
A1	0	0.02	0.05	0	0.02	0.05	0	0.02	0.05
A2	0.20 REF			0.20 REF			0.20 REF		
k	0.25	-	-	0.25	-	-	0.25	-	-

EXPOSED PAD VARIATIONS								
PKG CODES	D2			E2			PIN ID	JEDEC
	MIN.	NOM.	MAX.	MIN.	NOM.	MAX.		
TQ833-1	0.25	0.70	1.25	0.25	0.70	1.25	0.35 x 45°	WEEC
T1233-1	0.95	1.10	1.25	0.95	1.10	1.25	0.35 x 45°	WEED-1
T1233-3	0.95	1.10	1.25	0.95	1.10	1.25	0.35 x 45°	WEED-1
T1233-4	0.95	1.10	1.25	0.95	1.10	1.25	0.35 x 45°	WEED-1
T1633-2	0.95	1.10	1.25	0.95	1.10	1.25	0.35 x 45°	WEED-2
T1633F-3	0.65	0.80	0.95	0.65	0.80	0.95	0.225 x 45°	WEED-2
T1633FH-3	0.65	0.80	0.95	0.65	0.80	0.95	0.225 x 45°	WEED-2
T1633-4	0.95	1.10	1.25	0.95	1.10	1.25	0.35 x 45°	WEED-2
T1633-5	0.95	1.10	1.25	0.95	1.10	1.25	0.35 x 45°	WEED-2

NOTES:

- DIMENSIONING & TOLERANCING CONFORM TO ASME Y14.5M-1994.
- ALL DIMENSIONS ARE IN MILLIMETERS. ANGLES ARE IN DEGREES.
- N IS THE TOTAL NUMBER OF TERMINALS.
- THE TERMINAL #1 IDENTIFIER AND TERMINAL NUMBERING CONVENTION SHALL CONFORM TO JESD 95-1 SPP-012. DETAILS OF TERMINAL #1 IDENTIFIER ARE OPTIONAL, BUT MUST BE LOCATED WITHIN THE ZONE INDICATED. THE TERMINAL #1 IDENTIFIER MAY BE EITHER A MOLD OR MARKED FEATURE.
- DIMENSION b APPLIES TO METALLIZED TERMINAL AND IS MEASURED BETWEEN 0.20 mm AND 0.25 mm FROM TERMINAL TIP.
- ND AND NE REFER TO THE NUMBER OF TERMINALS ON EACH D AND E SIDE RESPECTIVELY.
- DEPOPULATION IS POSSIBLE IN A SYMMETRICAL FASHION.
- COPLANARITY APPLIES TO THE EXPOSED HEAT SINK SLUG AS WELL AS THE TERMINALS.
- DRAWING CONFORMS TO JEDEC MO220 REVISION C.
- MARKING IS FOR PACKAGE ORIENTATION REFERENCE ONLY.
- NUMBER OF LEADS SHOWN ARE FOR REFERENCE ONLY.
- WARPAGE NOT TO EXCEED 0.10mm.

-DRAWING NOT TO SCALE-

TITLE: PACKAGE OUTLINE 8, 12, 16L THIN QFN, 3x3x0.8mm		
APPROVAL	DOCUMENT CONTROL NO. 21-0136	REV. 1 2/2

Maxim cannot assume responsibility for use of any circuitry other than circuitry entirely embodied in a Maxim product. No circuit patent licenses are implied. Maxim reserves the right to change the circuitry and specifications without notice at any time.

22 **Maxim Integrated Products, 120 San Gabriel Drive, Sunnyvale, CA 94086 408-737-7600**