



Chipsmall Limited consists of a professional team with an average of over 10 year of expertise in the distribution of electronic components. Based in Hongkong, we have already established firm and mutual-benefit business relationships with customers from,Europe,America and south Asia,supplying obsolete and hard-to-find components to meet their specific needs.

With the principle of “Quality Parts,Customers Priority,Honest Operation,and Considerate Service”,our business mainly focus on the distribution of electronic components. Line cards we deal with include Microchip,ALPS,ROHM,Xilinx,Pulse,ON,Everlight and Freescale. Main products comprise IC,Modules,Potentiometer,IC Socket,Relay,Connector.Our parts cover such applications as commercial,industrial, and automotives areas.

We are looking forward to setting up business relationship with you and hope to provide you with the best service and solution. Let us make a better world for our industry!



## Contact us

Tel: +86-755-8981 8866 Fax: +86-755-8427 6832

Email & Skype: info@chipsmall.com Web: www.chipsmall.com

Address: A1208, Overseas Decoration Building, #122 Zhenhua RD., Futian, Shenzhen, China





# MAX9632 Evaluation Kit

**Evaluates: MAX9632**

## General Description

The MAX9632 evaluation kit (EV kit) provides a proven design to evaluate the MAX9632 low-noise, precision and wide-band op amp. The MAX9632 can be used in a wide variety of applications such as test and measurement, instrumentation, medical imaging, control loops, and professional audio. Because of the ultra-low noise and great precision, it can either drive high-resolution (18 to 24 bits) ADCs or buffer high-resolution DACs. The EV kit circuit can easily be adapted by installing shunts and changing a few components to support multiple op-amp configurations: transimpedance, noninverting, inverting, or differential amplifier. The components on the EV kit have pads that accommodate 0805 packages, making them easy to solder and replace. The EV kit accepts a single-supply voltage from +4.5V to +36V or a dual-supply voltage from  $\pm 2.25V$  to  $\pm 18V$ .

## Features

- ◆ Accommodates Multiple Op-Amp Configurations
- ◆ +4.5V to +36V Wide Input Supply Range
- ◆ Shutdown Input
- ◆ 0805 Components
- ◆ Proven PCB Layout
- ◆ Fully Assembled and Tested

## Ordering Information

PART	TYPE
MAX9632EVKIT+	EV Kit

+Denotes lead(Pb)-free and RoHS compliant.

## Component List

DESIGNATION	QTY	DESCRIPTION
C1, C3	2	0.1 $\mu$ F $\pm 10\%$ , 50V X7R ceramic capacitors (0805) Murata GRM21BR71H104K TDK C2012X7R1H104K
C2, C4	2	4.7 $\mu$ F $\pm 10\%$ , 50V X5R ceramic capacitors (1210) Murata GRM32ER71H475M TDK C3225X7R1H475M
C5, C6, C7	0	Not installed, ceramic capacitors (0805)
JU1, JU2	2	2-pin headers

DESIGNATION	QTY	DESCRIPTION
JU3	1	3-pin header
R1	0	Not installed, resistor (0805)
R2, R4	2	100 $\Omega$ $\pm 1\%$ resistors (0805)
R3, R5	2	0 $\Omega$ resistors (0805)
U1	1	Single high-voltage op amp (8 TDFN) Maxim MAX9632ATA+
—	3	Shunts
—	1	PCB: MAX9632 EVALUATION KIT+

## Component Suppliers

SUPPLIER	PHONE	WEBSITE
Murata Electronics North America, Inc.	770-436-1300	www.murata-northamerica.com
TDK Corp.	847-803-6100	www.component.tdk.com

**Note:** Indicate that you are using the MAX9632 when contacting these component suppliers.



# MAX9632 Evaluation Kit

## Quick Start

### Required Equipment

- MAX9632 EV kit
- $\pm 15\text{V}$ , 40mA DC power supply (PS1)
- +1V precision voltage source
- Digital multimeter (DMM)

### Procedure

The EV kit is fully assembled and tested. Follow the steps below to verify board operation:

- 1) Connect the positive terminal of the +15V supply to the VCC pad and the GND terminal to the GND pad. Connect the negative terminal of the -15V supply to the VEE pad and the GND terminal to the GND pad. The power supplies should be off.
- 2) Connect the positive terminal of the precision voltage source to the IN- pad. Connect the negative terminal of the precision voltage source to the IN+ pad.
- 3) Install a shunt on jumper JU2 to short IN+ to GND.
- 4) With the  $100\Omega$  feedback resistor and on-board  $100\Omega$  resistor, the gain is -1 (inverting configuration).
- 5) Connect the DMM to monitor the voltage on the OUT pad.
- 6) Turn on the  $\pm 15\text{V}$  power supply.
- 7) Apply 1V from the precision voltage source. Observe the output at the OUT pad on the DMM. OUT should read approximately -1V.

## Detailed Description of Hardware

The MAX9632 EV kit provides a proven layout for the MAX9632 low-noise op amp to support multiple op-amp configurations. The device accepts a single-supply voltage from +4.5V to +36V, or a dual-supply voltage from  $\pm 2.25\text{V}$  to  $\pm 18\text{V}$ .

### Jumper Selection

Jumpers JU1 and JU2 are provided to allow flexibility in grounding inputs for multiple op-amp configurations. When a shunt is installed on JU1 or JU2, the corresponding input pad is referenced to ground. See Table 1 for JU1 and JU2 configuration. See the *Op-Amp Configuration* section for more information regarding EV kit configuration.

### Shutdown Mode (SHDN)

Jumper JU3 controls the shutdown mode (SHDN) of the device. When SHDN is pulled low, the device is enabled. When the SHDN pin is pulled high, the device is disabled. See Table 2 for JU3 configuration.

**Table 1. JU1/JU2 Jumper Selection**

SHUNT POSITION	IN-/IN+ INPUT
Installed	Connected to GND
Not installed*	Signal applied at IN-/IN+ pad

\*Default position.

**Table 2. JU3 Jumper Selection**

SHUNT POSITION	SHDN PIN	EV KIT FUNCTION
1-2	Connected to VCC	Disabled
2-3*	Connected to GND	Enabled

\*Default position.

# MAX9632 Evaluation Kit

## **Op-Amp Configuration Transimpedance Application**

To configure the EV kit as a transimpedance amplifier (TIA), replace R2 with a 0Ω resistor and install a shunt on jumper JU2. The output voltage of the TIA is the input current multiplied by the feedback resistor:

$$V_{OUT} = I_{IN} \times R4 + V_{OS}$$

where R4 is installed as a 100Ω resistor,  $I_{IN}$  is defined as IN current, and  $V_{OS}$  is the input offset voltage of the op amp. Use capacitor C6 (and C5, if applicable) to stabilize the op amp by rolling off high-frequency gain due to a large cable capacitance.

## **Inverting Configuration**

To configure the EV kit as an inverting amplifier, replace R2 and R4 with the desired 1% gain-setting resistors, install a shunt on jumper JU2, and feed a voltage  $V_{IN}$  between the IN- and IN+ pads. Install a shunt on JU2 to ground the IN+ input in this configuration. The output voltage is given by the following equation:

$$V_{OUT} = -\frac{R4}{R2}(V_{IN} + V_{OS})$$

The offset voltage  $V_{OS}$  can be either positive or negative.

## **Noninverting Configuration**

To configure the device as a noninverting amplifier, replace R2 and R4 with the desired 1% gain-setting resistors, install a shunt on jumper JU1, and feed a voltage  $V_{IN}$  between the IN+ and IN- pads. Install a shunt on JU1 to ground the IN- input in this configuration. The output voltage is given by the following equation:

$$V_{OUT} = \left(1 + \frac{R4}{R2}\right)(V_{IN})$$

## **Differential Amplifier**

To configure the EV kit as a differential amplifier, replace R1–R4 with appropriate resistors and install a shunt on jumper JU1. Make sure  $R1 = R4$  and  $R2 = R3$ . The CMRR of the differential amplifier is determined by the matching of the resistor ratios  $R4/R2$  and  $R1/R3$ :

$$V_{OUT} = \text{Gain}(I_{NP} - I_{NN}), \text{ where Gain} = \frac{R4}{R2} = \frac{R1}{R3}$$

## **Capacitive Loads**

Some applications require driving large capacitive loads. To improve the stability of the amplifier in such cases, replace R5 with a suitable resistor value to improve amplifier phase margin. The R5/C7 filter can also be used as an anti-alias filter or to limit amplifier output noise by reducing its output bandwidth.

# MAX9632 Evaluation Kit

Evaluates: MAX9632

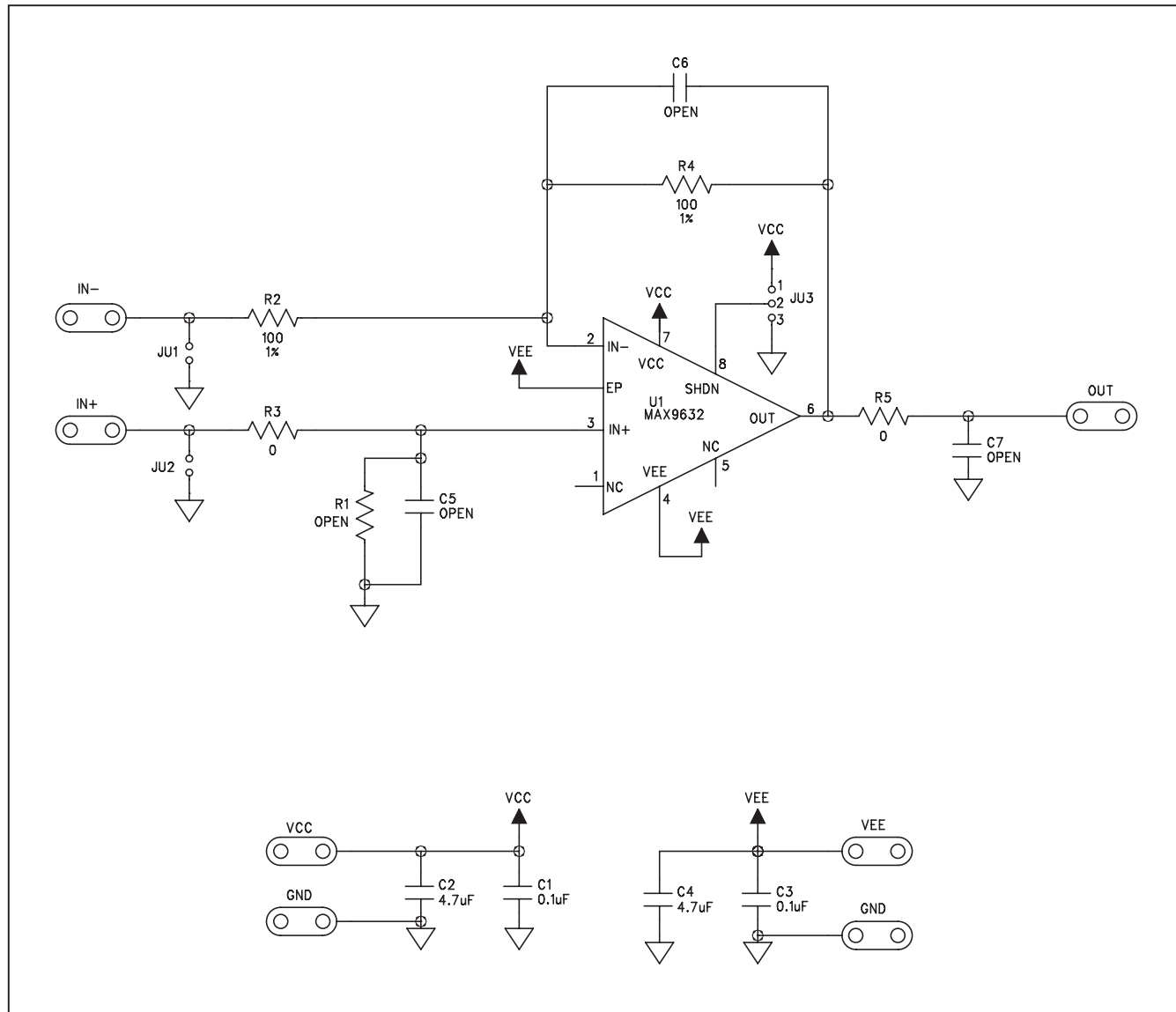

Figure 1. MAX9632 EV Kit Schematic

# MAX9632 Evaluation Kit

Evaluates: MAX9632

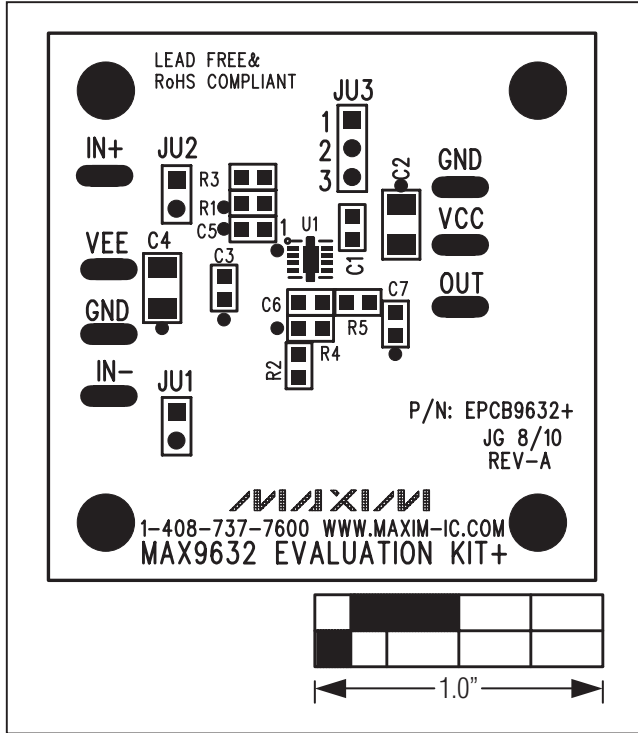

Figure 2. MAX9632 EV Kit Component Placement Guide—Component Side

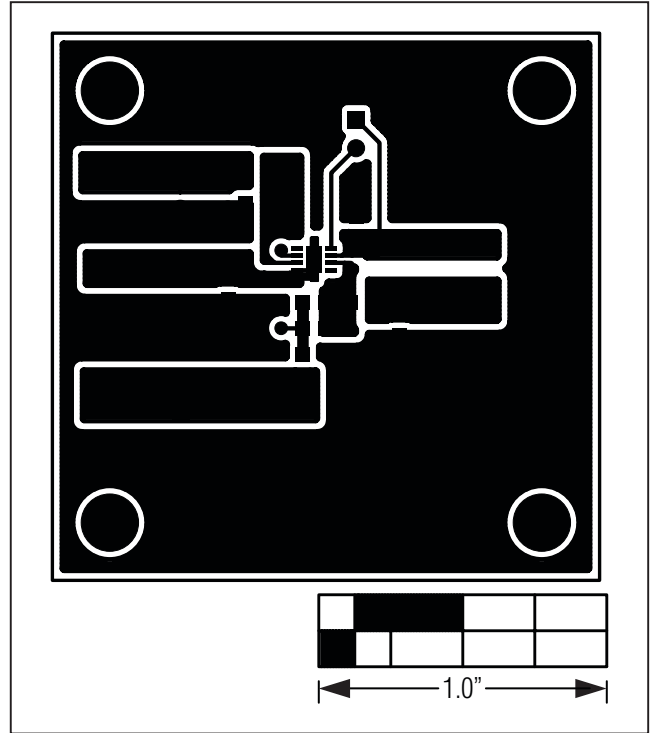

Figure 3. MAX9632 EV Kit PCB Layout—Component Side

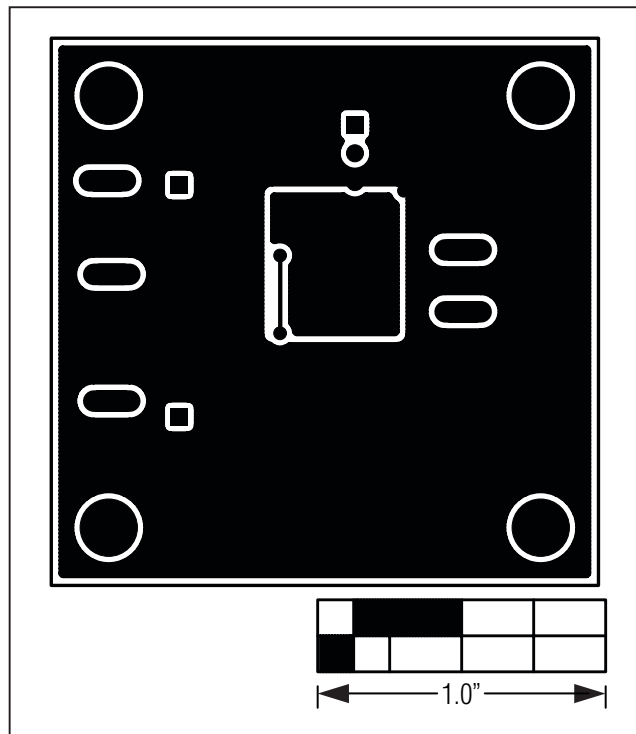

Figure 4. MAX9632 EV Kit PCB Layout—Solder Side

# MAX9632 Evaluation Kit

**Evaluates: MAX9632**

## Revision History

REVISION NUMBER	REVISION DATE	DESCRIPTION	PAGES CHANGED
0	10/10	Initial release	—

Maxim cannot assume responsibility for use of any circuitry other than circuitry entirely embodied in a Maxim product. No circuit patent licenses are implied. Maxim reserves the right to change the circuitry and specifications without notice at any time.

6 \_\_\_\_\_ **Maxim Integrated Products, 120 San Gabriel Drive, Sunnyvale, CA 94086 408-737-7600**

© 2010 Maxim Integrated Products

Maxim is a registered trademark of Maxim Integrated Products, Inc.