



Chipsmall Limited consists of a professional team with an average of over 10 year of expertise in the distribution of electronic components. Based in Hongkong, we have already established firm and mutual-benefit business relationships with customers from,Europe,America and south Asia,supplying obsolete and hard-to-find components to meet their specific needs.

With the principle of "Quality Parts,Customers Priority,Honest Operation,and Considerate Service",our business mainly focus on the distribution of electronic components. Line cards we deal with include Microchip,ALPS,ROHM,Xilinx,Pulse,ON,Everlight and Freescale. Main products comprise IC,Modules,Potentiometer,IC Socket,Relay,Connector.Our parts cover such applications as commercial,industrial, and automotives areas.

We are looking forward to setting up business relationship with you and hope to provide you with the best service and solution. Let us make a better world for our industry!



Contact us

Tel: +86-755-8981 8866 Fax: +86-755-8427 6832

Email & Skype: info@chipsmall.com Web: www.chipsmall.com

Address: A1208, Overseas Decoration Building, #122 Zhenhua RD., Futian, Shenzhen, China





MAX9634 Evaluation Kit

Evaluates: MAX9634

General Description

The MAX9634 evaluation kit (EV kit) provides a proven design to evaluate the MAX9634 high-side current-sense amplifier, which offers precision accuracy specifications of V_{OS} less than $250\mu V$ (max) and gain error less than 0.5% (max). This EV kit demonstrates the MAX9634 in a tiny $1\text{mm} \times 1\text{mm} \times 0.6\text{mm}$, 4-bump UCSP™ package. The MAX9634 is also available in a 5-pin SOT23, but that package is not compatible with this EV kit.

The EV kit PCB comes with a MAX9634FERS+ installed, which is the 50V/V gain version. Contact the factory for free samples of the pin-compatible MAX9634TERS+, MAX9634HERS+, and MAX9634WERS+, which are 25V/V, 100V/V, and 200V/V gain versions, respectively.

Features

- ◆ Precision Real-Time Current Monitoring
- ◆ 1.6V to 28V Input Common-Mode Range
- ◆ Proven PCB Layout
- ◆ Fully Assembled and Tested

Ordering Information

PART	TYPE
MAX9634EVKIT+	EV Kit

+Denotes lead(Pb)-free and RoHS compliant.

Component List

DESIGNATION	QTY	DESCRIPTION
C1	1	1 μF $\pm 10\%$, 50V X7R ceramic capacitor (1206) Murata GRM31MR71H105KA
C2	0	Not installed, ceramic capacitor (0603)
R1	1	0.05 Ω $\pm 0.5\%$, 0.5W 4-terminal current-sense resistor (1206) Ohmite LVK12R050DER
TP1, TP2	2	Test points
U1	1	Precision current-sense amplifier (4 UCSP) Maxim MAX9634FERS+ (Gain: 50V/V) (Top Mark: +ABY)
—	1	PCB: MAX9634 EVALUATION KIT+

Component Suppliers

SUPPLIER	PHONE	WEBSITE
Murata Electronics North America Inc.	770-436-1300	www.murata-northamerica.com
Ohmite Mfg. Co.	866-964-6483	www.ohmite.com

Note: Indicate that you are using the MAX9634 when contacting these component suppliers.

UCSP is a trademark of Maxim Integrated Products, Inc.



Maxim Integrated Products 1

For pricing, delivery, and ordering information, please contact Maxim Direct at 1-888-629-4642, or visit Maxim's website at www.maxim-ic.com.

MAX9634 Evaluation Kit

Quick Start

Recommended Equipment

- MAX9634 EV kit
- 3.6V, 1A DC power supply
- An electronic load capable of sinking 800mA (e.g., HP 6060B)
- Two digital voltmeters

Procedure

The MAX9634 EV kit is fully assembled and tested. Follow the steps below to verify board operation. **Caution: Do not turn on the power supply or electronic load until all connections are completed.**

- 1) Connect the positive terminal of the 3.6V supply to the VBATT pad and the negative terminal of the supply to the GND pad closest to the VBATT pad.
- 2) Set the electronic load to sink 800mA.
- 3) Connect the electronic load's positive terminal to the LOAD pad and the negative terminal to the GND pad closest to the bottom of the EV kit.
- 4) Connect the first voltmeter across test points TP1 and TP2 to measure VSENSE.
- 5) Connect the second voltmeter across the VOUT pad and the closest GND pad.
- 6) Turn on the power supply.
- 7) Turn on the electronic load.
- 8) Verify that the first voltmeter reading is approximately 40mV and the second voltmeter is approximately 2V.
- 9) Adjust the current load from 800mA to 0A and verify that the reading of the second voltmeter is approximately 50 times the reading of the first voltmeter.

Note: If the voltmeter has a 10M Ω input resistance, the output voltage reads 0.1% low.

Detailed Description of Hardware

The MAX9634 EV kit provides a proven design to evaluate the MAX9634 high-side current-sense amplifier, which offers precision accuracy specifications of V_{OS} less than 250 μ V (max) and gain error less than 0.5% (max).

Applying the VRS+ Supply and the Load

The EV kit is installed with a MAX9634FERS+, which has a gain of 50V/V. The current-sense resistor (R_{SENSE}) value is 0.05 Ω with \pm 0.5% tolerance. The voltage at the VOUT pad is given by:

$$V_{OUT} = (I_{LOAD} \times R_{SENSE} + V_{OS}) \times A_V$$

where V_{OS} is the offset, A_V is the gain, and I_{LOAD} is the current load applied to the device. Normal operating VRS+ and VRS- range is 1.6V to 28V.

Measuring the Load Current

The load current is measured as a voltage drop (V_{SENSE}) across an external sense resistor. This voltage is then amplified by the current-sense amplifier and presented at the VOUT pad. Like all differential amplifiers, the output voltage has two components of error (an offset error and a gain error). The offset error affects accuracy at low currents and the gain error affects accuracy at large currents—both errors affect accuracy at intermediate currents. By minimizing both offset and gain errors, accuracy is optimized over a wide dynamic range.

Evaluating Other Gain Versions

The MAX9634 EV kit can also be used to evaluate other gain versions of the MAX9634 (25V/V, 100V/V, or 200V/V with a T, H, or W suffix, respectively). Replace U1 on the EV kit with a different version of the MAX9634 IC.

MAX9634 Evaluation Kit

Evaluates: MAX9634

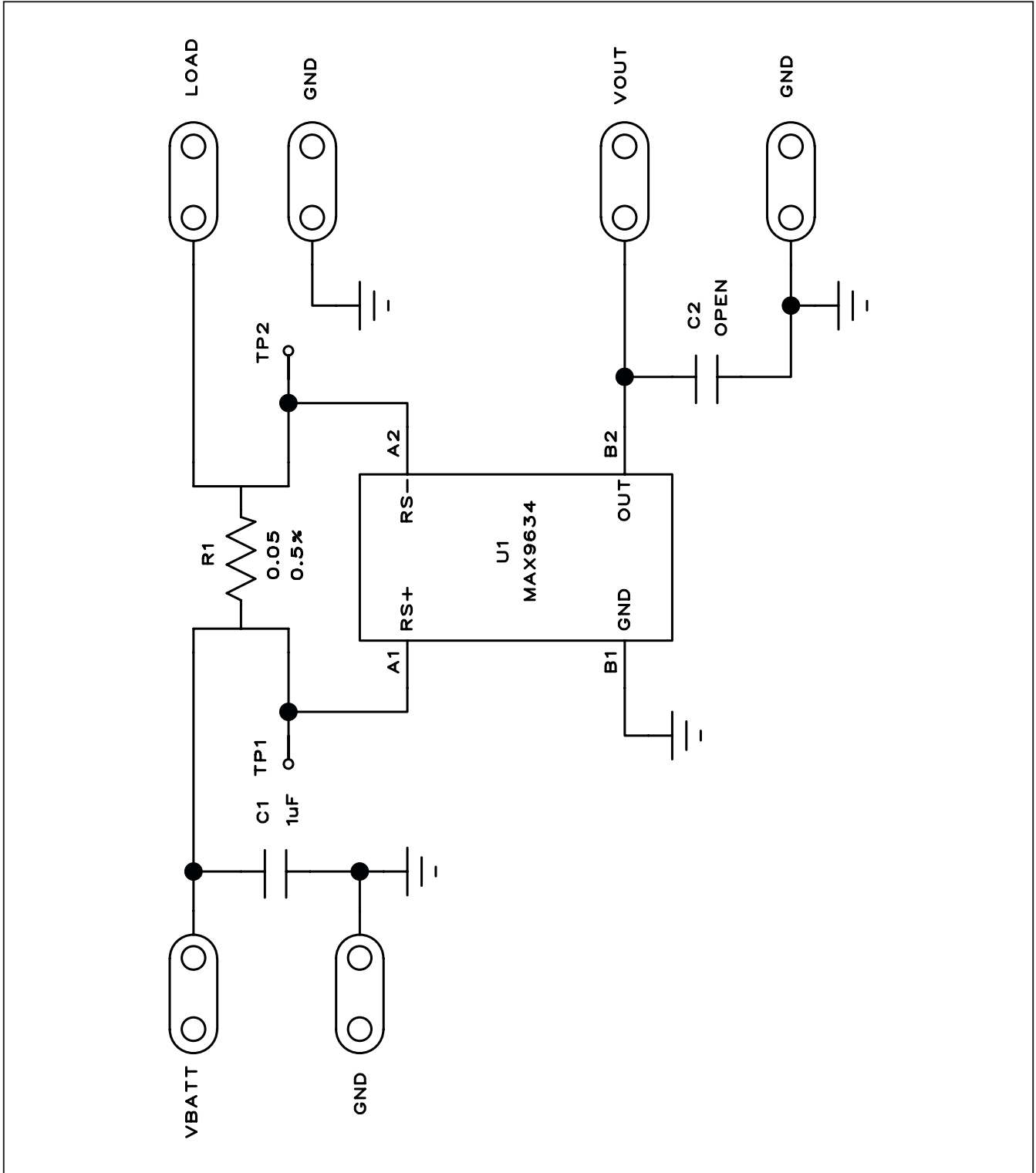

Figure 1. MAX9634 EV Kit Schematic

MAX9634 Evaluation Kit

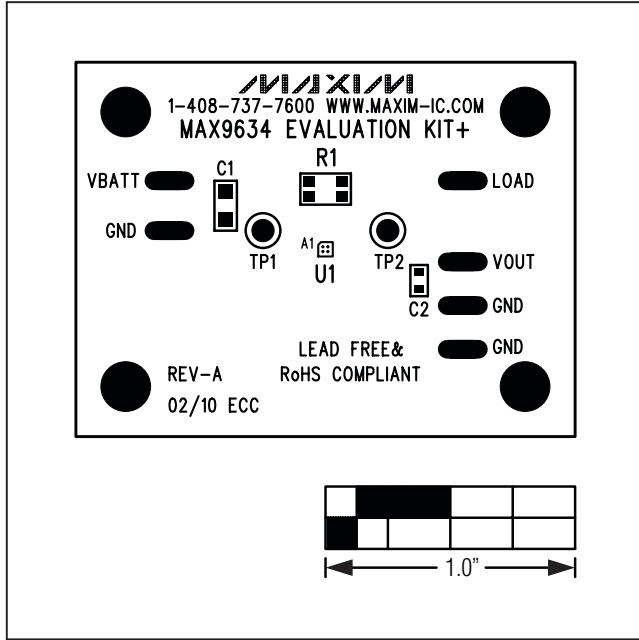

Figure 2. MAX9634 EV Kit Component Placement Guide—Component Side

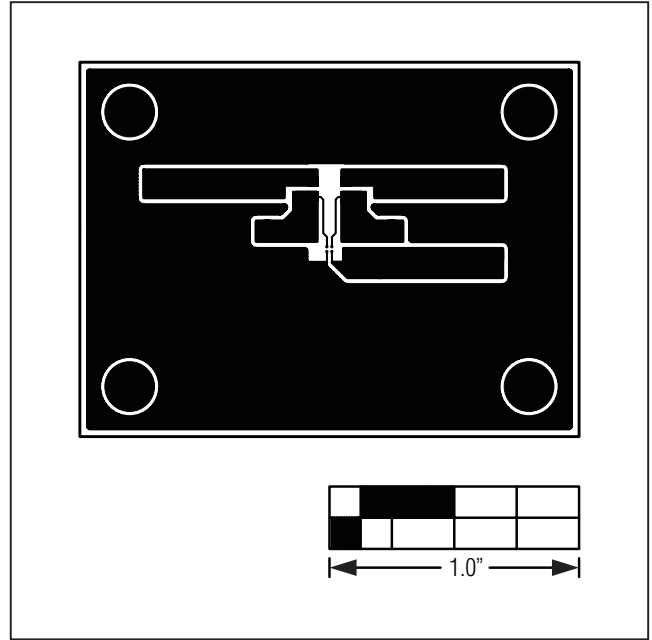

Figure 3. MAX9634 EV Kit PCB Layout—Component Side

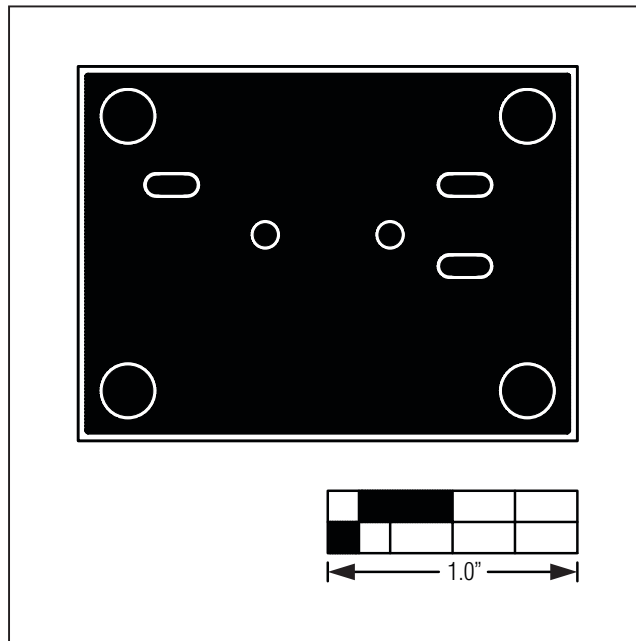

Figure 4. MAX9634 EV Kit PCB Layout—Solder Side

Maxim cannot assume responsibility for use of any circuitry other than circuitry entirely embodied in a Maxim product. No circuit patent licenses are implied. Maxim reserves the right to change the circuitry and specifications without notice at any time.

4 _____ **Maxim Integrated Products, 120 San Gabriel Drive, Sunnyvale, CA 94086 408-737-7600**