



Chipsmall Limited consists of a professional team with an average of over 10 year of expertise in the distribution of electronic components. Based in Hongkong, we have already established firm and mutual-benefit business relationships with customers from,Europe,America and south Asia,supplying obsolete and hard-to-find components to meet their specific needs.

With the principle of “Quality Parts,Customers Priority,Honest Operation,and Considerate Service”,our business mainly focus on the distribution of electronic components. Line cards we deal with include Microchip,ALPS,ROHM,Xilinx,Pulse,ON,Everlight and Freescale. Main products comprise IC,Modules,Potentiometer,IC Socket,Relay,Connector.Our parts cover such applications as commercial,industrial, and automotives areas.

We are looking forward to setting up business relationship with you and hope to provide you with the best service and solution. Let us make a better world for our industry!



Contact us

Tel: +86-755-8981 8866 Fax: +86-755-8427 6832

Email & Skype: info@chipsmall.com Web: www.chipsmall.com

Address: A1208, Overseas Decoration Building, #122 Zhenhua RD., Futian, Shenzhen, China





MAX9928 Evaluation Kit

General Description

The MAX9928 evaluation kit (EV kit) provides a proven design to evaluate the MAX9928 uni-/bidirectional, high-side, current-sense amplifier, which offers precision accuracy specifications of $V_{OS} < 400\mu V$ and gain error $< 1.0\%$. This EV kit demonstrates the MAX9928 in an ultra-small, 1mm x 1.5mm x 0.6mm, 6-bump UCSP™ package. The MAX9928 is also available in an 8-pin μ MAX®, but that package is not compatible with this EV kit.

The MAX9928 EV kit PCB comes with a MAX9928FABT+ installed, which is the 5 $\mu A/mV$ gain version. The MAX9928 EV kit can also be used to evaluate the MAX9928T, MAX9929F, and MAX9929T (2 $\mu A/mV$, 50V/V, and 20V/V, respectively). This EV kit can also evaluate the MAX4372 in a footprint-compatible UCSP package. Contact the factory for free samples of the pin-compatible MAX9928TABT+, MAX9929FABT+, or MAX9929TABT+ devices.

Features

- ◆ Precision Real-Time Current Monitoring
- ◆ -0.1V to +28V Input Common-Mode Range
- ◆ Evaluates MAX9928, MAX9929, and MAX4372
- ◆ $V_{OS} < 0.4mV$; Gain Error $< 1\%$
- ◆ SIGN Bit to Show Charge/Discharge Current Flow
- ◆ Lead(Pb)-Free and RoHS Compliant
- ◆ Proven PCB Layout
- ◆ Fully Assembled and Tested

Ordering Information

PART	TYPE
MAX9928EVKIT+	EV Kit

+Denotes lead(Pb)-free and RoHS compliant.

Component List

DESIGNATION	QTY	DESCRIPTION
CIN, COUT	0	Not installed, capacitors (0603)
C3	1	0.1 $\mu F \pm 10\%$, 50V X7R ceramic capacitor (0603) Murata GRM188R71H104K
C4	1	1 $\mu F \pm 10\%$, 50V X5S ceramic capacitor (0603) Taiyo Yuden UMK107C5105KA

DESIGNATION	QTY	DESCRIPTION
RSENSE	1	0.1 $\Omega \pm 1\%$, 1/2W sensing resistor (1206) Vishay/Dale WSL1206R1000FEB18
RIN1, RIN2	0	Not installed, resistors—short
ROUT	1	10k $\Omega \pm 1\%$ resistor (0603)
U1	1	Precision current-sense amplifier (6 UCSP) Maxim MAX9928FABT+
—	1	PCB: MAX9928 Evaluation Kit+

Component Suppliers

SUPPLIER	PHONE	WEBSITE
Murata Electronics North America, Inc.	770-436-1300	www.murata-northamerica.com
Taiyo Yuden	800-348-2496	www.t-yuden.com
Vishay	402-563-6866	www.vishay.com

Note: Indicate that you are using the MAX9928 when contacting these component suppliers.

UCSP is a trademark and μ MAX is a registered trademark of Maxim Integrated Products, Inc.



Maxim Integrated Products 1

For pricing, delivery, and ordering information, please contact Maxim Direct at 1-888-629-4642, or visit Maxim's website at www.maxim-ic.com.

Evaluates: MAX9928/MAX9929/MAX4372

MAX9928 Evaluation Kit

Quick Start

Recommended Equipment

Before beginning, the following equipment is needed:

- MAX9928 EV kit
- 5V/10mA DC power supply
- 12V/1A DC power supply
- An electronic load capable of sinking 800mA (e.g., HP 6060B)
- Two digital voltmeters

Procedure

The MAX9928 EV kit is fully assembled and tested. Follow the steps below to verify board operation.

Caution: Do not turn on the power supply or the electronic load until all connections are completed.

- 1) Connect the positive terminal of the 5V supply to the VCC pad. Connect the negative terminal of the 5V supply to the GND pad.
- 2) Connect the positive terminal of the 12V supply to the RS+ pad. Connect the negative terminal of the 12V supply to the GND pad.
- 3) Set the electronic load to sink 500mA.
- 4) Connect the electronic load's positive terminal to the RS- pad and the negative terminal to the GND pad.
- 5) Connect the first voltmeter across the OUT and the GND pads.
- 6) Connect the second voltmeter across the SIGN and the GND pads.
- 7) Turn on the power supplies.
- 8) Turn on the electronic load.
- 9) Verify that the OUT voltmeter reading is approximately 2.5V and the SIGN voltmeter is approximately 5V. Take care not to load the internal 1M Ω pullup resistor on the SIGN pin when measuring this voltage.

Detailed Description of Hardware

The MAX9928 evaluation kit (EV kit) provides a proven design to evaluate the MAX9928 uni-/bidirectional, high-side, current-sense amplifier, which offers precision accuracy specifications of $V_{OS} < 400\mu\text{V}$ and gain error $< 1.0\%$.

Output Voltage Calculation

The MAX9928 EV kit is installed with a MAX9928FABT+, which has a gain of 5 $\mu\text{A}/\text{mV}$. The current-sense resistor (R_{SENSE}) value is 0.1 Ω with $\pm 1\%$ tolerance. The V_{OUT} is given by:

$$V_{OUT} = I_{LOAD} \times R_{SENSE} \times G_m \times R_{OUT}$$

where G_m is the gain and I_{LOAD} is the current load applied to the device. Vary R_{OUT} to change the effective voltage gain.

Applying VCC and VRS+ Supply Voltages

The normal operating range for V_{CC} is 2.5V to 5.5V for MAX9928/MAX9929. The normal operating range for V_{CC} is 2.7V to 28V for MAX4372.

The normal input common-mode range at V_{RS+} and V_{RS-} is -0.1V to +28V for MAX9928/MAX9929. The MAX4372 operates with an input range of 0V to 28V, but the total OUT error at 0V can be up to 28%.

Measuring the Load Current

The load current is measured as a voltage drop (V_{SENSE}) across an external sense resistor. This voltage is then amplified by the current-sense amplifier and presented as a current at its output pin and converted to a voltage by R_{OUT} . Like all differential amplifiers, the output voltage has two components of error: an offset error and a gain error. The offset error affects accuracy at small V_{SENSE} and a gain error affects accuracy at large V_{SENSE} . By minimizing both offset and gain errors, accuracy can be optimized over a wide dynamic range.

MAX9928 Evaluation Kit

Evaluating SIGN Output for MAX9928/MAX9929

The MAX9928 and MAX9929 have a digital SIGN output to indicate the direction of the load current flow (charge vs. discharge current for a battery).

To evaluate current flowing in the opposite direction, swap the position of the 12V supply and the electronic load (connect the 12V supply to RS- and connect the electronic load to RS+). Verify that the OUT voltmeter still reads approximately 2.5V and the SIGN voltmeter has changed to 0V.

Evaluating MAX9929 or MAX4372

The MAX9929 and MAX4372 are voltage output devices with an internal $10k\Omega$ R_{OUT} resistor. When evaluating these devices, leave the MAX9928 EV kit R_{OUT} open.

Refer to the MAX9928/MAX9929 IC data sheet and/or the MAX4372 IC data sheet for more information.

Evaluates: MAX9928/MAX9929/MAX4372

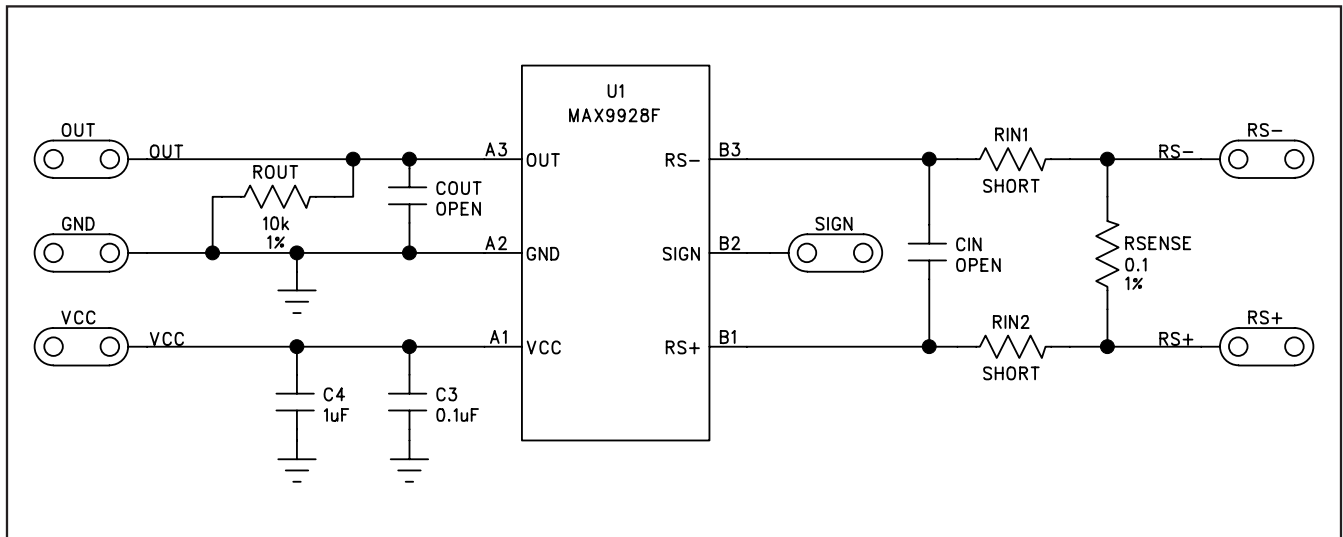

Figure 1. MAX9928F EV Kit Schematic

MAX9928 Evaluation Kit

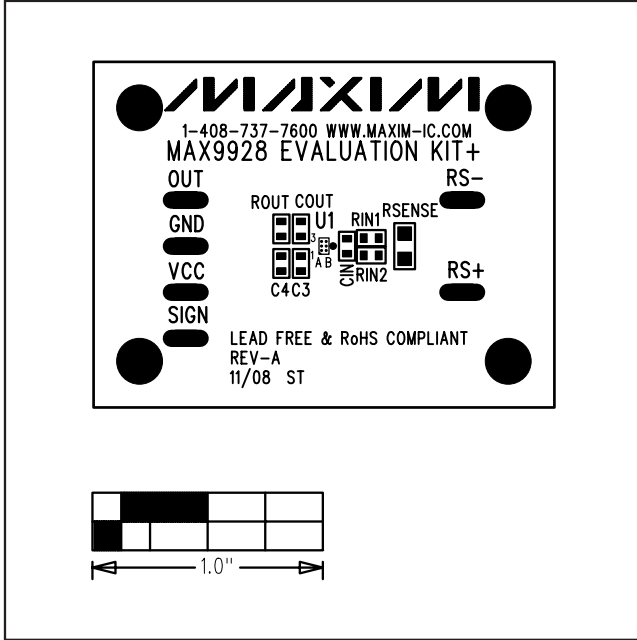

Figure 2. MAX9928 EV Kit Component Placement Guide—Component Side

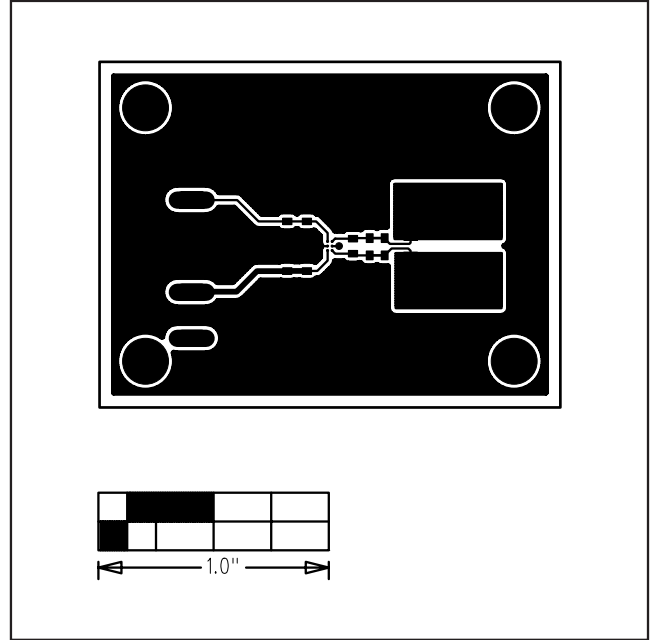

Figure 3. MAX9928 EV Kit PCB Layout—Component Side

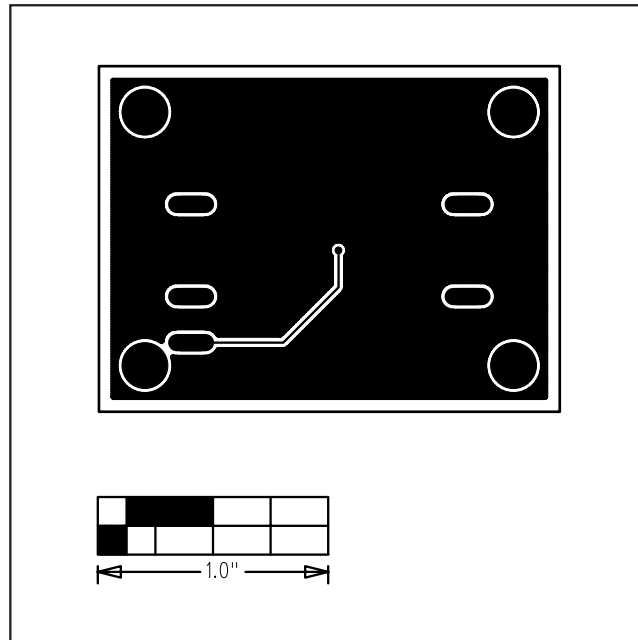

Figure 4. MAX9928 EV Kit PCB Layout—Solder Side

Maxim cannot assume responsibility for use of any circuitry other than circuitry entirely embodied in a Maxim product. No circuit patent licenses are implied. Maxim reserves the right to change the circuitry and specifications without notice at any time.

4 _____ **Maxim Integrated Products, 120 San Gabriel Drive, Sunnyvale, CA 94086 408-737-7600**