



Chipsmall Limited consists of a professional team with an average of over 10 year of expertise in the distribution of electronic components. Based in Hongkong, we have already established firm and mutual-benefit business relationships with customers from,Europe,America and south Asia,supplying obsolete and hard-to-find components to meet their specific needs.

With the principle of “Quality Parts,Customers Priority,Honest Operation,and Considerate Service”,our business mainly focus on the distribution of electronic components. Line cards we deal with include Microchip,ALPS,ROHM,Xilinx,Pulse,ON,Everlight and Freescale. Main products comprise IC,Modules,Potentiometer,IC Socket,Relay,Connector.Our parts cover such applications as commercial,industrial, and automotives areas.

We are looking forward to setting up business relationship with you and hope to provide you with the best service and solution. Let us make a better world for our industry!



Contact us

Tel: +86-755-8981 8866 Fax: +86-755-8427 6832

Email & Skype: info@chipsmall.com Web: www.chipsmall.com

Address: A1208, Overseas Decoration Building, #122 Zhenhua RD., Futian, Shenzhen, China



MAXM17546 5V Output Evaluation Kit

Evaluates: MAXM17546 5V Output

General Description

The *Himalaya* series of voltage regulator ICs and power modules enable cooler, smaller, and simpler power-supply solutions. The MAXM17546 5V-output evaluation kit (EV kit) is a demonstration circuit of the MAXM17546 42V, 5A high-efficiency, current-mode, synchronous step-down DC-DC switching power module. The EV kit operates over a wide input-voltage of 7.5V to 42V and provides up to 5A load current with a 5V-output voltage. The EV kit is programmed to switch at a frequency of 450kHz. The module is simple to use and easily configurable with minimal external components. It features cycle-by-cycle peak current-limit protection, under-voltage lockout (EN/UVLO), and thermal shutdown.

The EV kit comes with the compact 29-pin 15mm x 9mm x 4.32mm SiP package MAXM17546 module installed and is rated to operate over the full industrial -40°C to +125°C temperature range.

The MAXM17546 module data sheet provides a complete description of the part that should be read in conjunction with this data sheet prior to operating the EV kit. For full module features, benefits and parameters, refer to the MAXM17546 data sheet.

Features

- Wide 7.5V to 42V Input Range
- Highly Integrated Solution with Built-In Shielded Inductor
- Programmed 5V Output, Up To 5A Output Current
- All Ceramic Capacitors and Ultra-Compact Solution
- Selectable PWM, DCM, and PFM Modes
- Programmable 4ms Soft-Start Time and Prebias Startup
- Open-Drain RESET Output Pulled Up To 5V V_{CC}
- Programmable EN/UVLO Threshold
- Provision for External Frequency Synchronization
- Hiccup Overcurrent Protection (OCP)
- Overtemperature Protection (OTP)
- -40°C to +125°C Industrial Temperature Range

Ordering Information appears at end of data sheet.

Quick Start

Recommended Equipment

- MAXM17546EVKITB# evaluation kit
- 7.5V to 42V DC, 4A power supply
- Dummy load capable of sinking 5A
- Digital voltmeter (DVM)
- 100MHz dual-trace oscilloscope

Equipment Setup and Test Procedure

The MAXM17546 EV kit is fully assembled and tested. Follow the steps below to verify board operation. **Caution: Do not turn on the power supply until all connections are completed.**

- 1) Set the power supply at a voltage between 7.5V and 42V. Disable the power supply.
- 2) Connect the positive and negative terminals of the power supply to VIN and GND PCB pads, respectively.
- 3) Connect the positive and negative terminals of the 5A load to VOUT and GND PCB pads respectively, and the set the load to 0A.
- 4) Connect the DVM across the VOUT PCB pad and the GND PCB pad.
- 5) Verify that shunts are not installed on jumper J1 (see [Figure 2](#) for details).
- 6) Select the shunt position on jumper J2 according to the intended mode of operation (see [Table 2](#) for details).
- 7) Enable the input power supply.
- 8) Verify the DVM display 5V.
- 9) Increase the load up to 5A to verify the output voltage is 5V using DVM.

Detailed Description of Hardware

The MAXM17546 EV kit is a proven circuit to demonstrate the high-voltage, high-efficiency, and compact solution size of the MAXM17546 synchronous step-down DC-DC power module. The output voltage is preset to 5V to operate from 7.5V to 42V input and provides up to 5A load current. The optimal frequency is set at 450kHz to maximize efficiency and minimize component size. The EV kit includes four test points, TP1 for monitoring the $\overline{\text{RESET}}$, TP2 for measuring the LX voltage, TP3 for monitoring the DL voltage and TP4 for measuring the BST voltage.

Soft-Start Input (SS)

The MAXM17546 module implements adjustable soft-start operation to reduce inrush current. A capacitor connected from the SS pin to SGND programs the soft-start time. The selected output capacitance (C_{SEL}) and the output voltage (V_{OUT}) determine the minimum required soft-start capacitor as follows:

$$C_{\text{SS}} \geq 28 \times 10^{-6} \times C_{\text{SEL}} \times V_{\text{OUT}}$$

The soft-start time (t_{SS}) is related to the capacitor connected at SS (C_{SS}) by the following equation:

$$t_{\text{SS}} = C_{\text{SS}} / (5.55 \times 10^{-6})$$

where t_{SS} is in ms and C_{SS} is in nF. For example, to program a 4ms soft-start time, a 22nF capacitor should be connected from the SS pin to SGND.

Regulator Enable/ Undervoltage-Lockout Level (EN/UVLO)

The EV kit offers an adjustable input undervoltage-lockout level by resistor-dividers connecting between the IN, EN/UVLO, and GND pins. For normal operation, a shunt

should not be installed across pins 1-2 on JU1 to enable the output through an internal pullup 3.32M Ω resistor from the EN/UVLO pin to the IN pin. To disable the output, install the shunt across pins 1-2 on JU1 to pull the EN/UVLO pin to GND. See [Table 1](#) for JU1 setting details. The EV kit also provides an R3 resistor to program a UVLO threshold voltage at which an input-voltage level device turns on. The R3 resistor can be calculated by the following equation:

$$R3 = 3320 \times 1.215 / (V_{\text{INU}} - 1.215)$$

where V_{INU} is the input voltage at which the device is required to turn on, and R3 is in k Ω .

MODE/SYNC Selection (MODE)

The device's MODE pin can be used to select among the PWM, PFM, or DCM modes of operation. The logic state of the MODE pin is latched when the V_{CC} and EN/UVLO voltages exceed the respective UVLO rising thresholds and all internal voltages are ready to allow LX switching. State changes on the MODE pin are ignored during normal operation. Refer to the MAXM17546 IC data sheet for more information on the PWM, PFM, and DCM modes of operation.

[Table 2](#) lists JU2 jumper settings that can be used to configure the desired mode of operation. The internal oscillator of the device can be synchronized to an external clock signal on the SYNC pin. The external synchronization clock frequency must be between $1.1 \times f_{\text{SW}}$ and $1.4 \times f_{\text{SW}}$, where f_{SW} is the frequency of operation set by R4. The minimum external clock high pulse width should be greater than 50ns, while the minimum external clock low pulse width should be greater than 160ns.

Table 1. EN/UVLO Enable/Disable Configuration (JU1)

SHUNT POSITION	EN PIN	MAXM17546_OUTPUT
1-2	Connected to GND	Disabled
Not installed*	Connected to the center node of resistor-divider 3.32M Ω and R3	Enabled, UVLO level set through the 3.32M Ω and R3 resistors

*Default position

Table 2. MODE Description (JU2)

SHUNT POSITION	MODE PIN	MAXM17546_MODE
Not installed	Unconnected	PFM mode of operation
1-2	Connected to V_{CC}	DCM mode of operation
2-3*	Connected to GND	PWM mode of operation

*Default position

Table 3. EXT VCC Configuration (JU3)

SHUNT POSITION	EXTVCC PIN	MAXM17546_EXTVCC
Not installed	Unconnected	EXTVCC unused
1-2	Connected to GND	EXTVCC = GND
2-3*	Connected to V _{OUT}	EXTVCC = V _{OUT}

*Default position

MAXM17546 EV Kit Performance Report

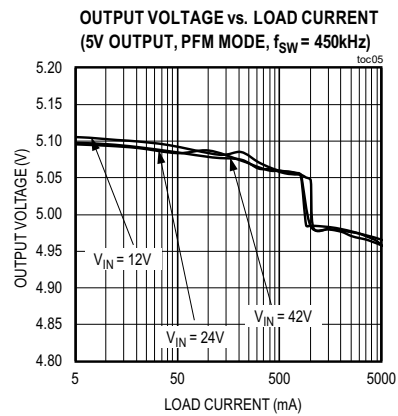
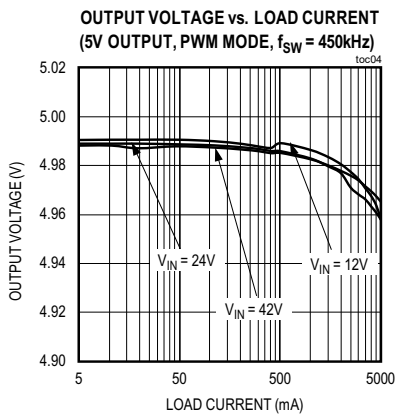
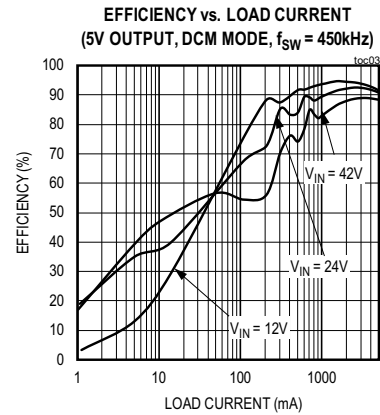
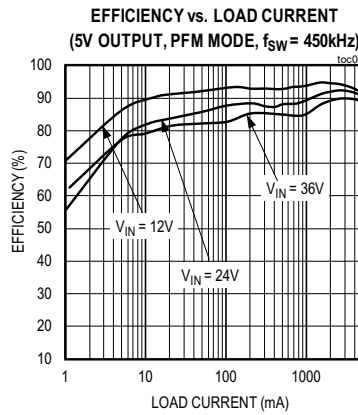
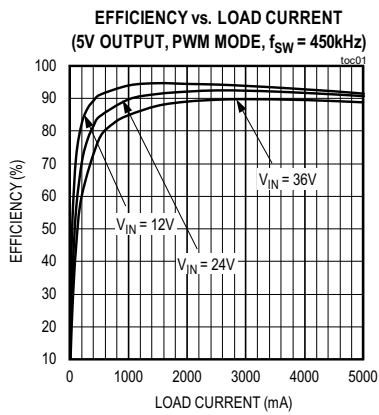

MAXM17546 EV Kit Performance Report (continued)

STEADY-STATE SWITCHING WAVEFORMS

($V_{IN} = 24V$, $V_{OUT} = 5V$, $I_{OUT} = 5A$
PWM MODE, MODE = SGND)

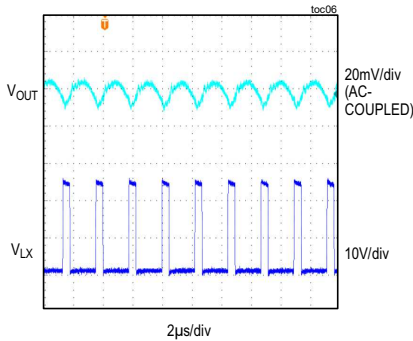

POWER-UP AND DOWN THROUGH EN/UVLO

($V_{IN} = 24V$, $V_{OUT} = 5V$, $I_{OUT} = 5A$
PWM MODE, MODE = SGND)

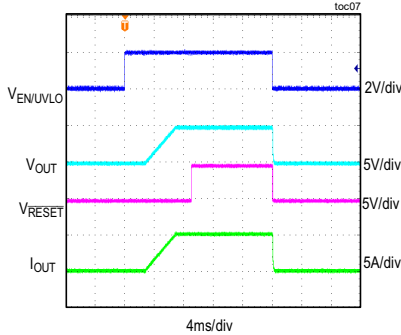

LOAD TRANSIENT

($V_{IN} = 24V$, $V_{OUT} = 5V$, $I_{OUT} = 0A$ TO $2.5A$
PWM MODE, MODE = SGND)

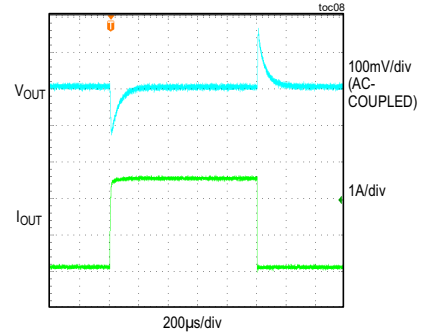

LOAD TRANSIENT

($V_{IN} = 24V$, $V_{OUT} = 5V$, $I_{OUT} = 2.5A$ TO $5A$
PWM MODE, MODE = SGND)

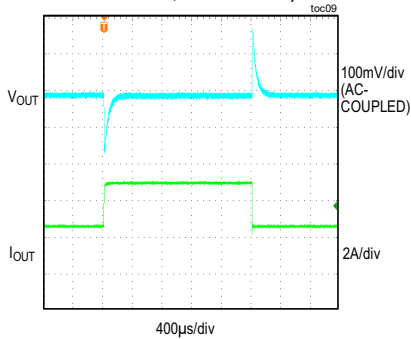

BODE PLOT

($V_{IN} = 24V$, $V_{OUT} = 5V$, $I_{OUT} = 5A$)

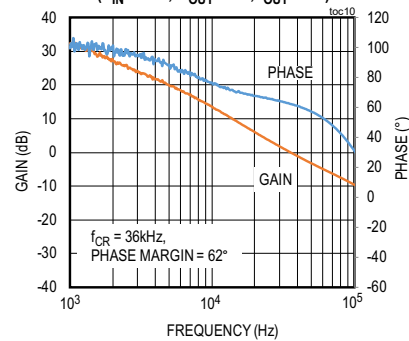

Ordering Information

PART	TYPE
MAXM17546EVKITB#	EV Kit

#Denotes RoHS compliant.

Component Suppliers

SUPPLIER	WEBSITE
TDK Corp.	www.tdk.com
Murata Americas	www.murata.com
Panasonic Corp.	www.panasonic.com
Vishay	www.vishay.com

Note: Indicate that you are using the MAXM17546 when contacting these component suppliers.

MAXM17546 5V Output Evaluation Kit

Evaluates: MAXM17546 5V Output

MAXM17546 EV Kit Bill of Materials

TITLE: Bill of Materials
 DATE: 03/16/2018
 DESIGN: maxm17546_evkit_b

ITEM	QTY	REF DES	Var Status	MAXINV	MFG PART #	MANUFACTURER	VALUE	DESCRIPTION
1	2	C1, C2	Pref	20-0010U-B40	GRM32ER1H106KA12; CL32B106KJNNN	MURATA;SAMSUNG ELECTRONICS	10UF	CAPACITOR; SMT (1210); CERAMIC CHIP; 10UF; 50V; TOL=10%; TG=-55 DEGC TO +125 DEGC; TC=X7R
2	1	C3	Pref	20-0047U-A17	EEE-FK1K470P	PANASONIC	47UF	CAPACITOR; SMT (CASE_G); ALUMINUM-ELECTROLYTIC; 47UF; 80V; TOL=20%
3	1	C4	Pref	20-0U022-91	C0603C223K5RAC; GRM188R71H223K; C1608X7R1H223K080AA	KEMET;MURATA;TDK	0.022UF	CAPACITOR; SMT (0603); CERAMIC CHIP; 0.022UF; 50V; TOL=10%; TG=-55 DEGC TO +125 DEGC; TC=X7R
4	3	C5, C6, C12	Pref	20-0022U-C8	C1210C226M4RAC; C3225X7R1C226M250AC; GRM32ER71C226MEA8	KEMET;TDK;MURATA	22UF	CAPACITOR; SMT (1210); CERAMIC CHIP; 22UF; 16V; TOL=20%; TG=-55 DEGC TO +125 DEGC; TC=X7R; NOTE: NOT RECOMMENDED FOR NEW DESIGN-USE 20-0022u-G9
5	1	C11	Pref	20-002P2-N6	06035J2R2BBT; GRM39C0G2R2B50V	AVX;MURATA	2.2PF	CAPACITOR; SMT (0603); CERAMIC CHIP; 2.2PF; 50V; TOL=+-0.1PF; MODEL=ACCU-P; TG=-55 DEGC TO +125 DEGC
6	2	C19, C20	Pref	20-000U1-04A	CGA2B3X7R1H104K; C1005X7R1H104K050B8; GRM155R71H104KE14	TDK;TDK;MURATA	0.1UF	CAPACITOR; SMT (0402); CERAMIC CHIP; 0.1UF; 50V; TOL=10%; TG=-55 DEGC TO +125 DEGC; TC=X7R
7	3	IN, OUT, PGND	Pref	01-9020BUSS20AWG-00	9020 BUSS	WEICO WIRE	MAXIMPAD	EVK KIT PARTS; MAXIM PAD; WIRE; NATURAL; SOLID; WEICO WIRE; SOFT DRAWN BUS TYPE-S; 20AWG
8	1	J1	Pref	01-PBC02SABN2P-21	PBC02SABN	SULLINS	PBC02SABN	CONNECTOR; MALE; THROUGH HOLE; BREAKAWAY; STRAIGHT; 2PINS
9	2	J2, J3	Pref	01-PBC03SABN3P-21	PBC03SABN	SULLINS	PBC03SABN	CONNECTOR; MALE; THROUGH HOLE; BREAKAWAY; STRAIGHT; 3PINS
10	4	J4-J7	Pref	02-57541P-01	575-4	KEYSTONE	575-4	RECEPTACLE; JACK; BANANA; 0.203IN [5.2MM] DIA X 0.218IN [5.5MM] L; 0.203D/0.218L; NICKEL PLATED BRASS
11	1	R1	Pref	80-0191K-24	CRCW0603191KFK	VISHAY DALE	191K	RESISTOR; 0603; 191K OHM; 1%; 100PPM; 0.10W; METAL FILM
12	1	R2	Pref	80-042K-24	CRCW060342K2FK	VISHAY DALE	42.2K	RESISTOR; 0603; 42.2K OHM; 1%; 100PPM; 0.10W; THICK FILM
13	1	R3	Pref	80-0665K-10	CRCW0603665KFK	VISHAY DALE	665K	RES; SMT (0603); 665K; 1%; +/-100PPM/DEGC; 0.1W
14	1	R5	Pref	80-0010K-24	CRCW060310K0FK;ERI-3EKF1002	VISHAY DALE;PANASONIC	10K	RESISTOR; 0603; 10K; 1%; 100PPM; 0.10W; THICK FILM
15	1	R8	Pref	80-0000R-27	CRCW06030000ZS;MCR03EZPJ000;ERI-3GEY0R00	VISHAY DALE;ROHM;PANASONIC	0	RESISTOR; 0603; 0 OHM; 0%; JUMPER; 0.10W; THICK FILM
16	3	SU1-SU3	Pref	02-JMPFSTC02SYAN-00	STC02SYAN	SULLINS ELECTRONICS CORP.	STC02SYAN	TEST POINT; JUMPER; STR; TOTAL LENGTH=0.256IN; BLACK; INSULATION=PBT CONTACT=PHOSPHOR BRONZE; COPPER PLATED TIN OVERALL
17	4	TP1-TP4	Pref	02-TPMINI5000-00	5000	KEYSTONE	N/A	TEST POINT; PIN DIA=0.1IN; TOTAL LENGTH=0.3IN; BOARD HOLE=0.04IN; RED; PHOSPHOR BRONZE WIRE SILVER PLATE FINISH; RECOMMENDED FOR BOARD THICKNESS=0.062IN; NOT FOR COLD TEST
18	1	U1	Pref	00-SAMPLE-01	MAXM17546	MAXIM	MAXM17546	EVKIT PART -IC; LGA 15MMX9MMX4.42MM; 32LD; 1.27 PITCH
19	1	VCC	Pref	02-TPCOMP5005-00	5005	KEYSTONE	N/A	TEST POINT; PIN DIA=0.125IN; TOTAL LENGTH=0.35IN; BOARD HOLE=0.063IN; RED; PHOSPHOR BRONZE WIRE SILVER PLATE FINISH; RECOMMENDED FOR BOARD THICKNESS=0.062IN
20	1	PCB	-	EPCBM17546	MAXM17546	MAXIM	PCB	PCB:MAXM17546
TOTAL	35							

MAXM17546 5V Output Evaluation Kit

Evaluates: MAXM17546 5V Output

MAXM17546 EV Kit Schematic

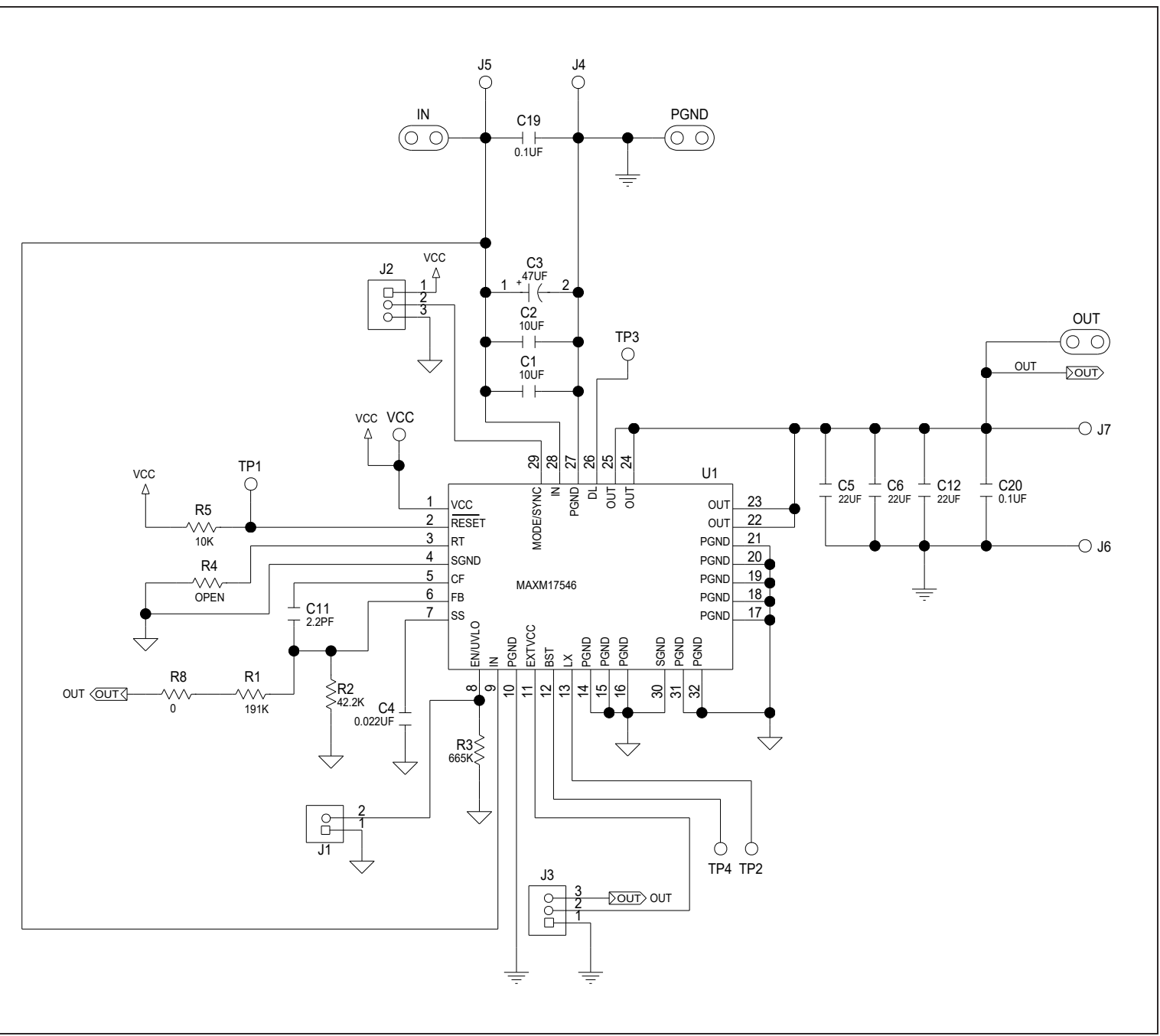

MAXM17546 EV Kit PCB Layout

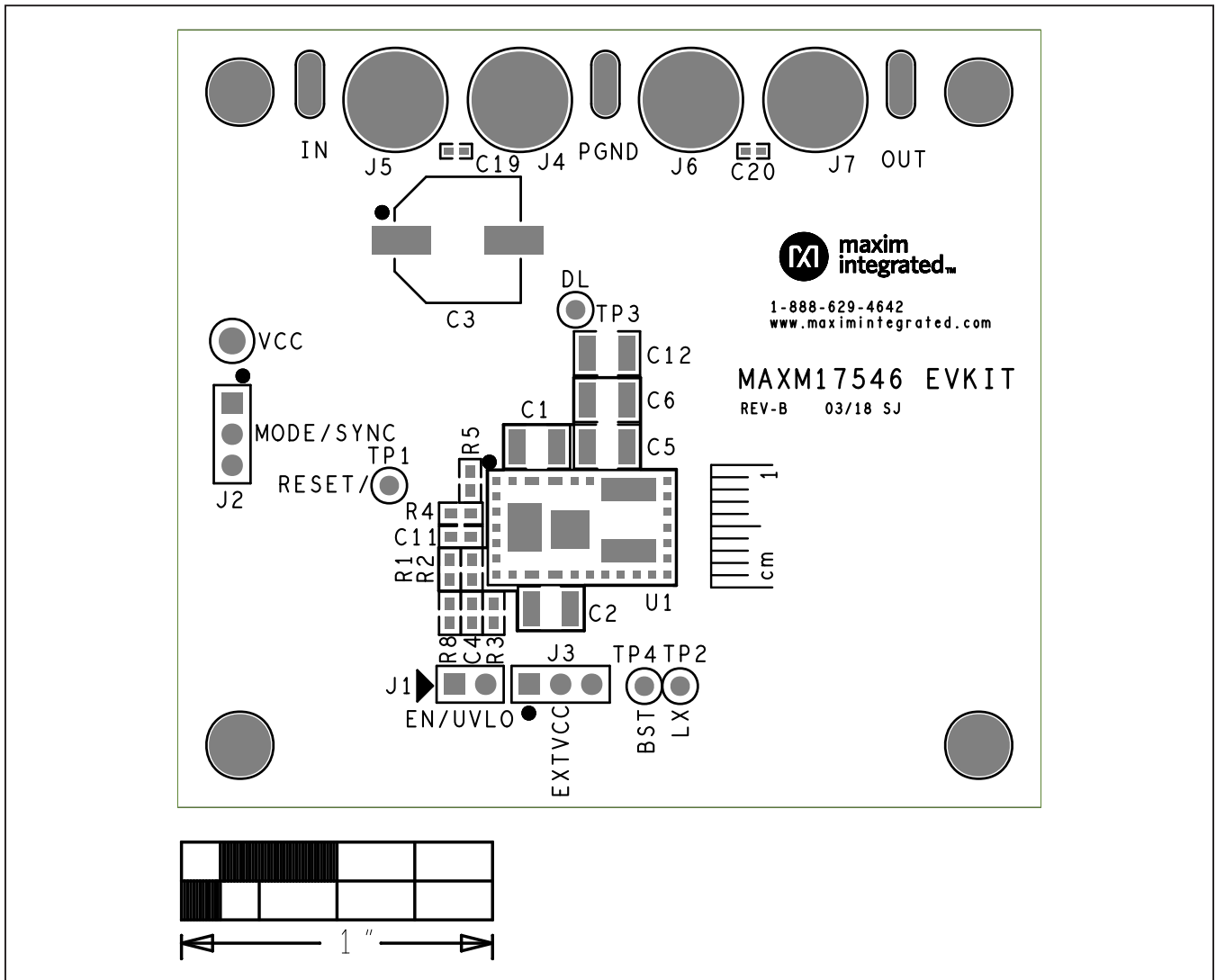

Figure 1. MAXM17546 5V Output EV kit PCB Layout—Top Silkscreen

MAXM17546 EV Kit PCB Layout (continued)

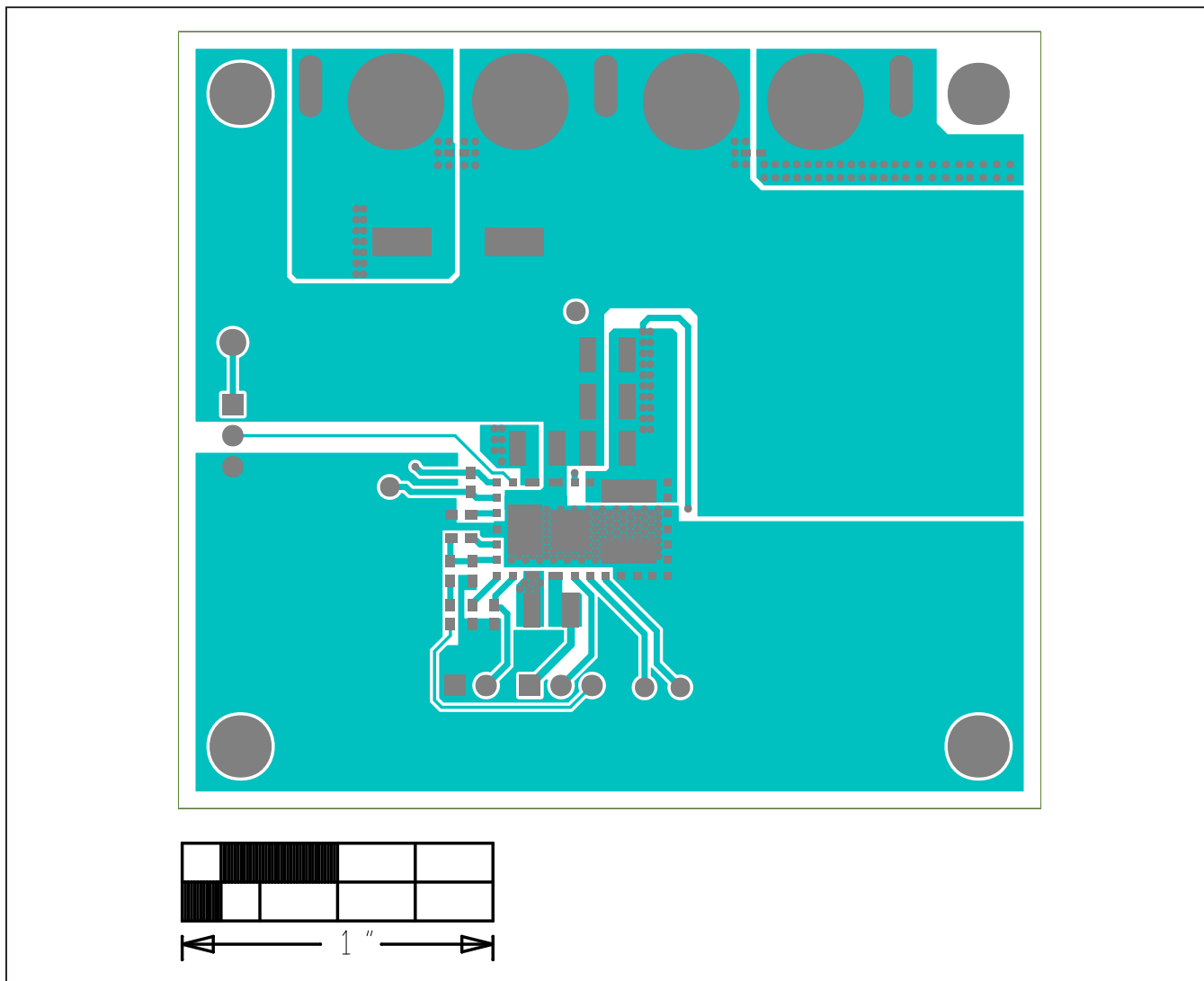

Figure 2. MAXM17546 5V Output EV kit PCB Layout---Top Layer

MAXM17546 EV Kit PCB Layout (continued)

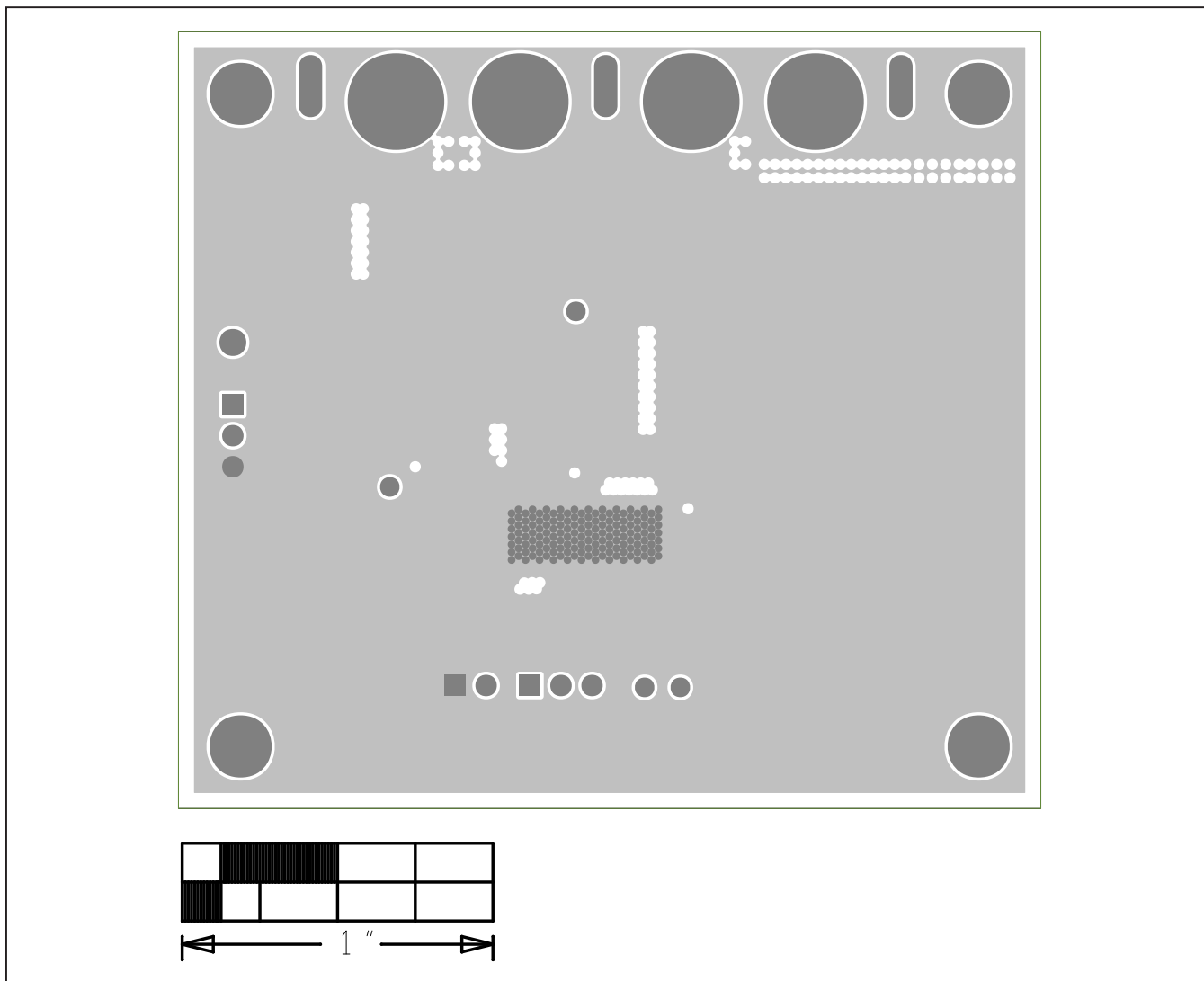

Figure 3. MAXM17546 5V Output EV kit PCB Layout—Layer 2

MAXM17546 EV Kit PCB Layout (continued)

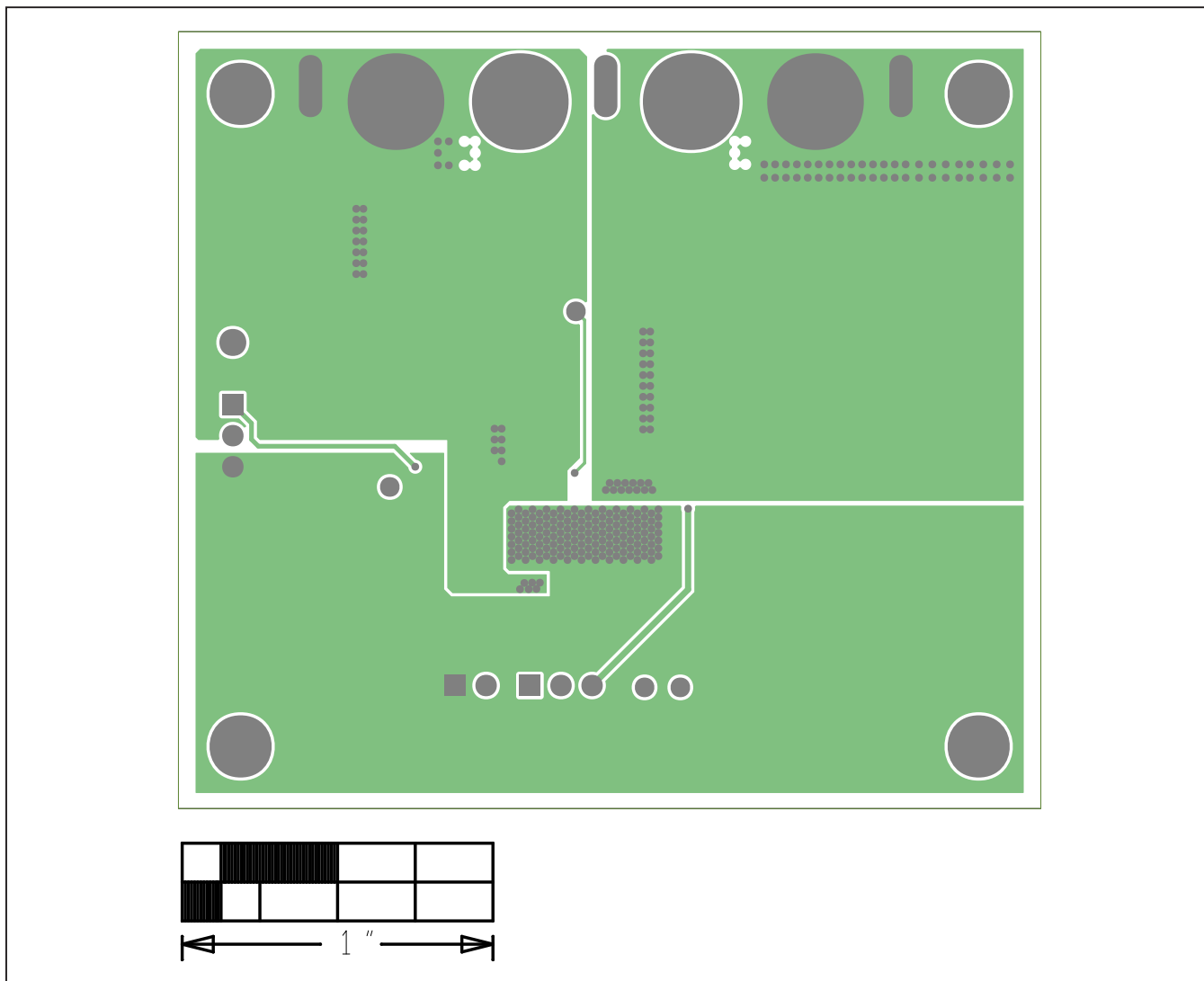

Figure 4. MAXM17546 5V Output EV kit PCB Layout—Layer 3

MAXM17546 EV Kit PCB Layout (continued)

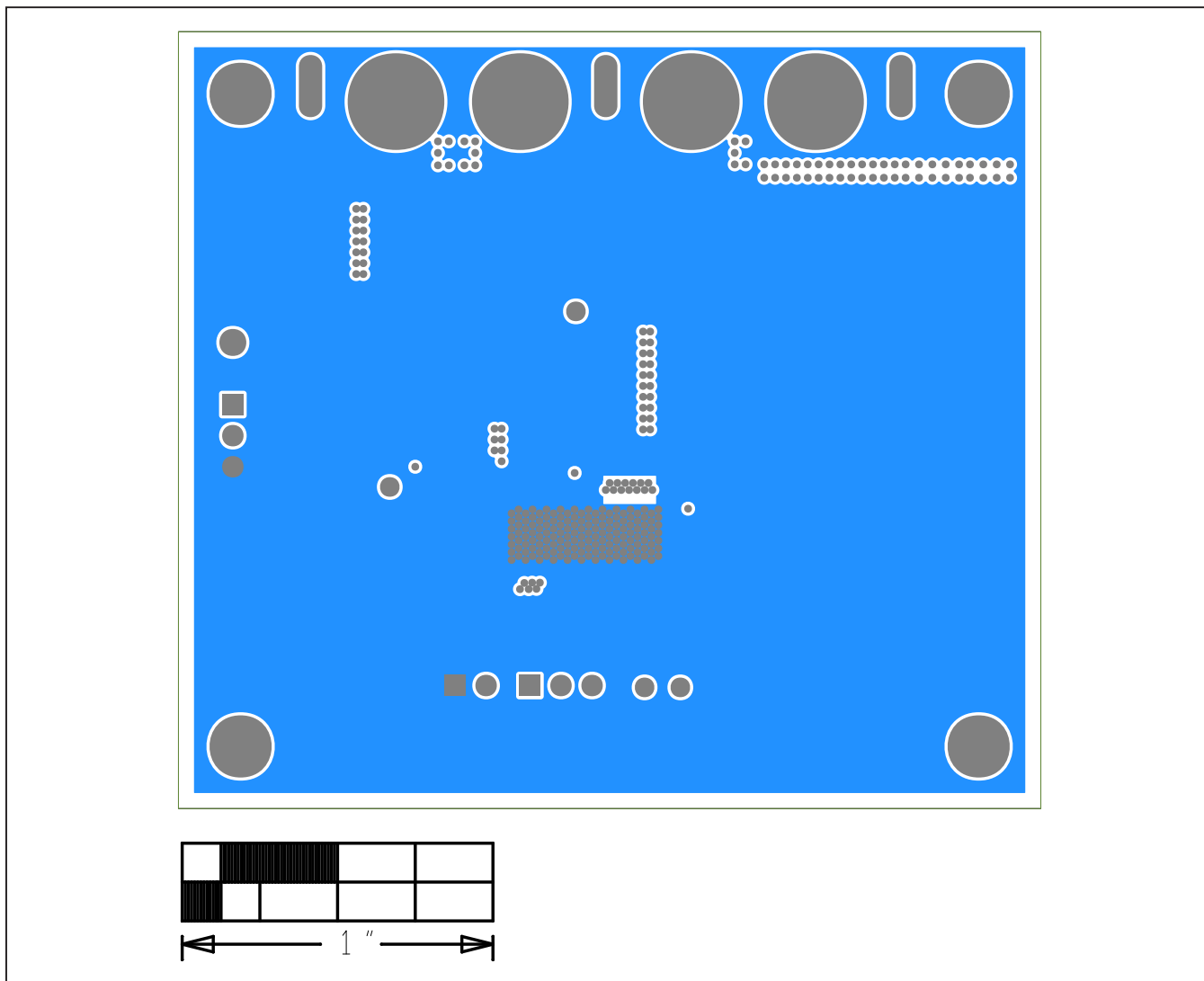

Figure 5. MAXM17546 5V Output EV kit PCB Layout—Bottom Silkscreen

Revision History

REVISION NUMBER	REVISION DATE	DESCRIPTION	PAGES CHANGED
0	4/18	Initial release	—

For pricing, delivery, and ordering information, please contact Maxim Direct at 1-888-629-4642, or visit Maxim Integrated's website at www.maximintegrated.com.

Maxim Integrated cannot assume responsibility for use of any circuitry other than circuitry entirely embodied in a Maxim Integrated product. No circuit patent licenses are implied. Maxim Integrated reserves the right to change the circuitry and specifications without notice at any time.