



Chipsmall Limited consists of a professional team with an average of over 10 year of expertise in the distribution of electronic components. Based in Hongkong, we have already established firm and mutual-benefit business relationships with customers from,Europe,America and south Asia,supplying obsolete and hard-to-find components to meet their specific needs.

With the principle of "Quality Parts,Customers Priority,Honest Operation,and Considerate Service",our business mainly focus on the distribution of electronic components. Line cards we deal with include Microchip,ALPS,ROHM,Xilinx,Pulse,ON,Everlight and Freescale. Main products comprise IC,Modules,Potentiometer,IC Socket,Relay,Connector.Our parts cover such applications as commercial,industrial, and automotives areas.

We are looking forward to setting up business relationship with you and hope to provide you with the best service and solution. Let us make a better world for our industry!



## Contact us

Tel: +86-755-8981 8866 Fax: +86-755-8427 6832

Email & Skype: info@chipsmall.com Web: www.chipsmall.com

Address: A1208, Overseas Decoration Building, #122 Zhenhua RD., Futian, Shenzhen, China



# MAXM17575 5V Output Evaluation Kit

# Evaluates: MAXM17575 5V Output Application

## General Description

The MAXM17575 5V output evaluation kit (EV kit) provides a proven design to evaluate the MAXM17575 high-voltage, high-efficiency, synchronous step-down DC-DC power module. The EV kit is preset for 5V output at load currents up to 1.5A and features a 900kHz switching frequency for optimum efficiency and component size. The EV kit features an adjustable input undervoltage lockout, adjustable soft-start, open-drain  $\overline{\text{RESET}}$  signal, and external frequency synchronization. The MAXM17575 module data sheet provides a complete description of the part that should be read in conjunction with this data sheet prior to operating the EV kit. For full features, benefits and parameters of the MAXM17575 module, refer to the MAXM17575 data sheet.

## Features

- Highly-Integrated Solution with Built-In Shielded Inductor
- Wide 7.5V to 60V Input Range
- Programmed 5V Output, up to 1.5A Output Current
- High 92% Efficiency ( $V_{\text{IN}} = 12\text{V}$ ,  $V_{\text{OUT}} = 5\text{V}$  at 0.5A)
- 900kHz Switching Frequency
- Enable/UVLO Input, Resistor-Programmable UVLO Threshold
- Programmed 1ms Soft-Start Time
- PWM Mode of Operation
- Open-Drain  $\overline{\text{RESET}}$  Output
- External Frequency Synchronization
- Overcurrent and Overtemperature Protection
- Low-Profile, Surface-Mount Components
- Proven PCB Layout
- Fully Assembled and Tested
- CISPR-22 Class B Compliant

## Quick Start

### Recommended Equipment

- One 7.5V to 60V DC, 2A power supply
- 7.5W resistive load with 1.5A sink capacity
- Four digital multimeters (DMM)
- One MAXM17575 EVKIT# EV kit

### Equipment Setup and Test Procedure

The EV kit is fully assembled and tested. Follow the steps below to verify the board operation.

**Caution:** Do not turn on power supply until all connections are completed.

- 1) Set the input power supply at a voltage between 7.5V and 60V. Disable the power supply.
- 2) Connect the positive terminal of the power supply to the VIN\_EMI pad and the negative terminal to the nearest PGND pad. Connect the positive terminal of the 1.5A load to the VOUT pad and the negative terminal to the nearest PGND pad.
- 3) Connect a DVM (DMM in Voltage measurement mode) across the VOUT pad and the nearest PGND pad.
- 4) Verify that shunts are not installed on jumper J1 (see [Table 1](#) for details).
- 5) Turn on the input power supply.
- 6) Enable the load.
- 7) Verify that the DVM displays 5V across the output terminals.

*[Ordering Information](#) appears at end of data sheet.*





# MAXM17575 5V Output Evaluation Kit

# Evaluates: MAXM17575 5V Output Application

## Detailed Description

The MAXM17575 EV kit is designed to demonstrate the salient features of the MAXM17575 power module. The MAXM17575 EV kit includes an EN/UVLO pad and jumper J1 to enable the output at a desired input voltage. The RT/SYNC pad allows an external clock interface to synchronize the device. An additional  $\overline{\text{RESET}}$  pad is available for monitoring if the converter output voltage is in regulation.

On the bottom layer of the EV kit, additional footprints for optional components are included to ease board modification for different input/output configurations. Placeholders are also available on the bottom layer for installation of EMI filter components. EMI component values are provided in the schematic.

## Setting the Switching Frequency

Selection of switching frequency must consider input voltage range and desired output voltage,  $t_{\text{ON(MIN)}}$  and  $t_{\text{OFF(MIN)}}$  of the MAXM17575. To optimize efficiency and component size, a switching frequency of 900kHz is chosen for the 5V output. Resistor R1, connected between the RT/SYNC and SGND pins, programs the desired switching frequency. Referring to Table 1 in the MAXM17575 data sheet, R1 is chosen to be 21.5k $\Omega$ . See Table 1 in the MAXM17575 data sheet to see the various switching frequency recommendations for optimized various output designs.

## Input Capacitor Selection

The input capacitor serves to reduce the current peaks drawn from the input power supply and also reduce switching frequency voltage ripple at the input. Refer to Table 1 in the MAXM17575 data sheet to see the summary of input capacitor choices for various requirements. Using this table, the input capacitor (C5) for this EV kit is chosen to be 2.2 $\mu\text{F}/100\text{V}$ .

## Output Capacitor Selection

X7R ceramic output capacitors are preferred due to their stability over temperature in industrial applications. Refer to Table 1 in the MAXM17575 data sheet to see a summary of output capacitor choices for various requirements. Using this table, the output capacitor (C13) for this EV kit is chosen to be 22 $\mu\text{F}/10\text{V}$ .

## Adjusting Output Voltage

The MAXM17575 supports an adjustable output voltage range, from 0.9V to 12V, using a feedback resistive divider from OUT to FB. To get different output voltages, refer to Table 1 in the MAXM17575 data sheet. R7 and

R8 of the EV kit correspond to RU and RB in Table 1 of MAXM17575 data sheet.

## Soft-Start Programming

MAXM17575 offers an adjustable soft-start function to limit inrush current during startup. In this EV kit SS pin is connected to SS\_C using short trace to have default 1ms soft-start time. The soft-start time can be increased by adding C11, the external capacitor from SS pin to SGND. The capacitance required for additional soft-start time ( $t_{\text{SS}}$ ) is given by the following equation:

$$C11 = 5.55 \times 10^{-6} \times t_{\text{SS}}$$

## Enable/Undervoltage Lockout (EN/UVLO) Programming

The MAXM17575 has an internal pullup resistor (3.3M $\Omega$ ) from EN/UVLO to VIN to enable a default start up. The device offers an adjustable input under voltage lockout feature. In this EV kit, for normal operation, leave the jumper J1 open. To disable the output, install a jumper across pins 1-2 on J1. See Table 1 for J1 settings. Resistor R3 connected from EN/UVLO to SGND sets the input voltage ( $V_{\text{INU}}$ ) at which the device should turn on. Value of R3 resistor is calculated as follows:

$$R3 \geq \frac{3.3 \times 1.215}{(V_{\text{INU}} - 1.215)}$$

where R3 is in k $\Omega$ .

For the MAXM17575 to turn on at 7.0V input, the resistor (R3) is calculated to be 698k $\Omega$ .

## External Clock Synchronization (RT/SYNC)

The internal oscillator of the MAXM17575 can be synchronized to an external clock signal through the RT/SYNC pin. The external synchronization clock frequency must be between  $1.1 \times f_{\text{SW}}$  and  $1.4 \times f_{\text{SW}}$ , where  $f_{\text{SW}}$  is the frequency programmed by the R1 resistor. When an external clock is applied to the RT/SYNC pin, the internal oscillator frequency synchronizes to external clock frequency (from original frequency based on the RT setting) after detecting 16 external clock edges. The minimum external clock high pulse width and amplitude should be greater than 50ns and 2.1V, respectively. The maximum external clock low pulse amplitude should be less than 0.8V.

**EXTVCC Linear Regulator**

Powering VCC from EXTVCC\_C increases the efficiency at higher input voltages. If the EXTVCC\_C voltage is greater than 4.7V (typ), VCC is powered from EXTVCC\_C. If EXTVCC\_C is lower than 4.7V (typ), VCC is powered from VIN. Refer to MAXM17575 data sheet for further information. Resistor R6 (0Ω) connects EXTVCC\_C to EXTVCC\_R in this EV kit.

**Electromagnetic Interference (EMI)**

Compliance to conducted emissions (CE) standards requires an EMI filter at the input of a switching power converter. The EMI filter attenuates high-frequency currents drawn by the switching power converter and limits the noise injected back into the input power source.

The MAXM17575 EV kit PCB has designated footprints on the bottom side for placement of EMI filter compo-

nents. Use of EMI filter components as shown in the schematic results in lower conducted emissions, below CISPR22 Class B limits. Cut open the trace at L1, before installing EMI filter components. The MAXM17575 EV kit PCB layout is also designed to limit radiated emissions from switching nodes of the power converter, resulting in radiated emissions below CISPR22 Class B limits.

**Hot Plug-In and Long Input Cables**

The MAXM17575 EV kit PCB provides an optional electrolytic capacitor (C2, 10μF/100V). This capacitor limits the peak voltage at the input of the MAXM17575 power module, when the DC input source is hot pulged to the EV kit input terminals with long input cables. The equivalent series resistance (ESR) of the electrolytic capacitor dampens the oscillations caused by interaction of the inductance of the long input cables, and the ceramic capacitors at the power module input.

**Table 1. UVLO Enable/Disable Configuration (J1)**

POSITION	EN/UVLO PIN	MAXM17575 OUTPUT
Not installed*	Connected to the center node of resistor-divider 3.3MΩ(internal) and R3	Programmed to startup at desired input voltage level
1-2	Connected to SGND	Disabled

\*Default position

# MAXM17575 5V Output Evaluation Kit

# Evaluates: MAXM17575 5V Output Application

## EV Kit Performance Report

( $V_{IN} = 24V$ ,  $V_{OUT} = 5V$ ,  $I_{OUT} = 1.5A$ ,  $T_A = +25^\circ C$ . All voltages are referenced to SGND, unless otherwise noted.)

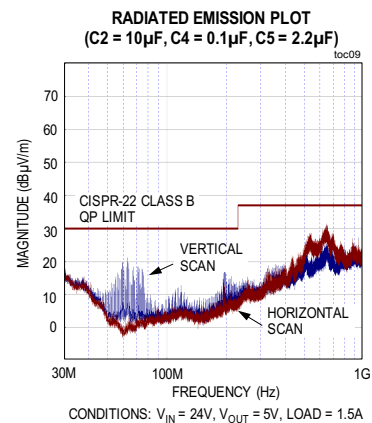
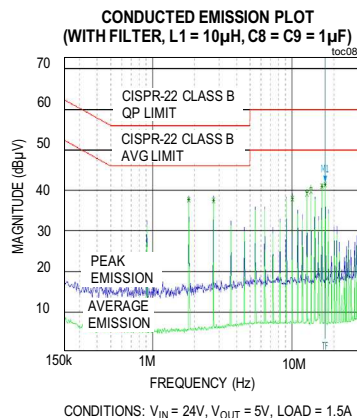
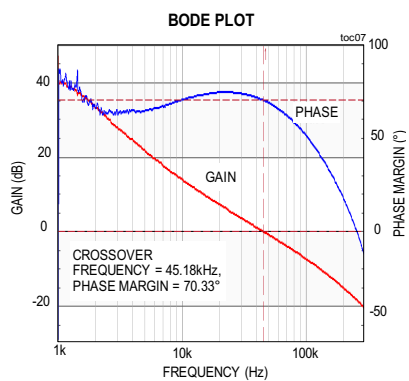
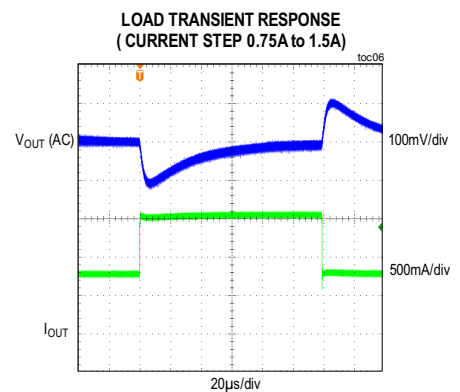
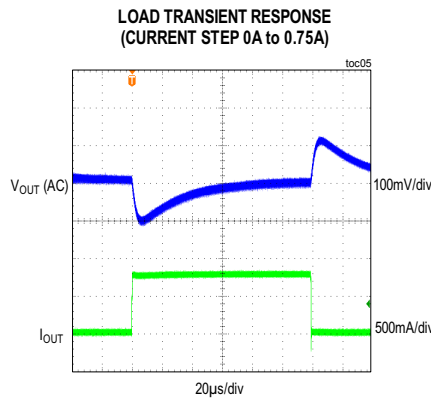
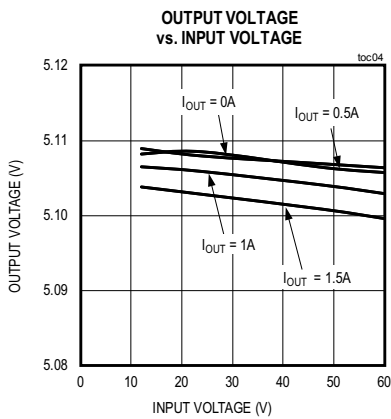
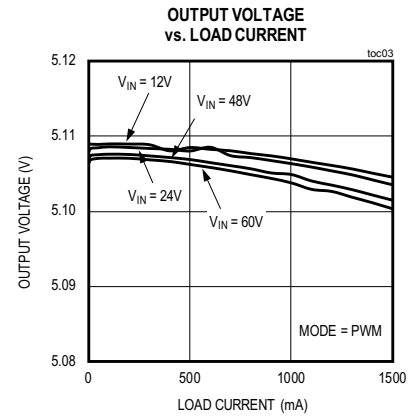
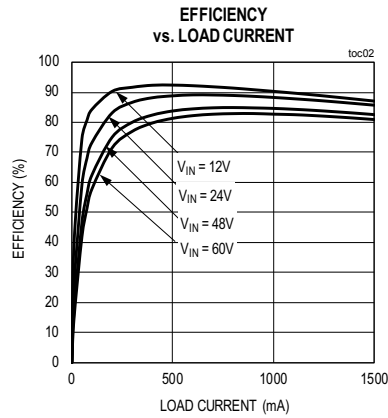
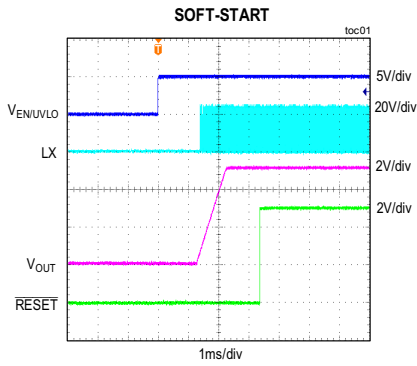

## MAXM17575 5V EV Kit Bill of Materials

S NO	DESIGNATION	QTY	DESCRIPTION	MANUFACTURER PARTNUMBER-1	MANUFACTURER PARTNUMBER-2
1	C1	1	100pF±10%, 50V, C0G Ceramic Capacitor (0402)	KEMET C0402C101K5GAC	TDK C1005C0G1H101K050BA
2	C2	1	10µF±20%, 100V, Aluminum Capacitor	PANASONIC EEE-TG2A100P	
3	C3	1	OPEN ,4.7µF±10%, 10V, X7R Ceramic Capacitor (0805)	TDK C2012X7R1A475K085AC	
4	C4	1	0.1µF±10%, 100V, X7R Ceramic Capacitor(0603)	MURATA GRM188R72A104KA35	YAGEO CC0603KRX7R0BB104
5	C5	1	2.2µF±10%, 100V, X7R Ceramic Capacitor (1210)	MURATA GRM32ER72A225KA35	TDK CGA6N3X7R2A225K230
6	C6	1	47pF±5%, 50V, C0G Ceramic Capacitor (0402)	VENKEL LTD C0402C0G500-470JNE	MURATA GRM1555C1H470JA01
7	C7	1	OPEN ,1µF±10%, 100V, X7R Ceramic Capacitor (1210)	MURATA GRM32CR72A105KA35	
8	C8	1	OPEN ,1µF±10%, 100V, X7R Ceramic Capacitor (1210)	MURATA GRM32CR72A105KA35	
9	C9	1	OPEN ,1µF±10%, 100V, X7R Ceramic Capacitor (1210)	MURATA GRM32CR72A105KA35	
10	C10	1	OPEN (0603)		
11	C11	1	OPEN (0603)		
12	C12	1	OPEN (0603)		
13	C13	1	22µF±10%, 10V, X7R Ceramic Capacitor (1210)	MURATA GRM32ER71A226K	
14	C14	1	OPEN(0603)		
15	R1	1	21.5kΩ ±1% Resistor (0402)	PANASONIC ERJ-2RKF2152	
16	R3	1	698kΩ ±1% Resistor (0402)	PANASONIC ERJ-2RKF6983	
17	R4	1	1kΩ ±1% Resistor (0402)	VISHAY DALE CRCW04021K00FK	YAGEO RC0402FR-071KL
18	R5	1	10kΩ ±1% Resistor (0402)	VISHAY DALE CRCW040210K0FK	YAGEO RC0402FR-0710K
19	R6	1	0 Ω Resistor (0402)	VISHAY DALE CRCW04020000Z0EDHP	VISHAY DALE RCS04020000Z0
20	R7	1	75kΩ ±1% Resistor (0402)	VISHAY DALE CRCW040275K0FK	
21	R8	1	16.2kΩ ±1% Resistor (0402)	PANASONIC ERJ2RKF1622	
22	FB1	1	OPEN	OPEN	
23	L1	1	OPEN (10µH ±20%, 2A Inductor)	PULSE PA4332.103NLT	
24	U1	1	MAXM17575, 28-pin SIP Power Module	MAXM17575ALI#	

## Ordering Information

PART	TYPE
MAXM17575EVKIT#	EV Kit

#Denotes RoHS compliant.

## Component Suppliers

SUPPLIER	WEBSITE
Murata Americas	<a href="http://www.murata.com">www.murata.com</a>
Panasonic Corp.	<a href="http://www.panasonic.com">www.panasonic.com</a>
Vishay	<a href="http://www.vishay.com">www.vishay.com</a>
TDK Corp.	<a href="http://www.component.tdk.com">www.component.tdk.com</a>

**Note:** Indicate that you are using MAXM17575 when contacting these component suppliers.

# MAXM17575 5V Output Evaluation Kit

# Evaluates: MAXM17575 5V Output Application

## MAXM17575 5V EV Kit Schematic

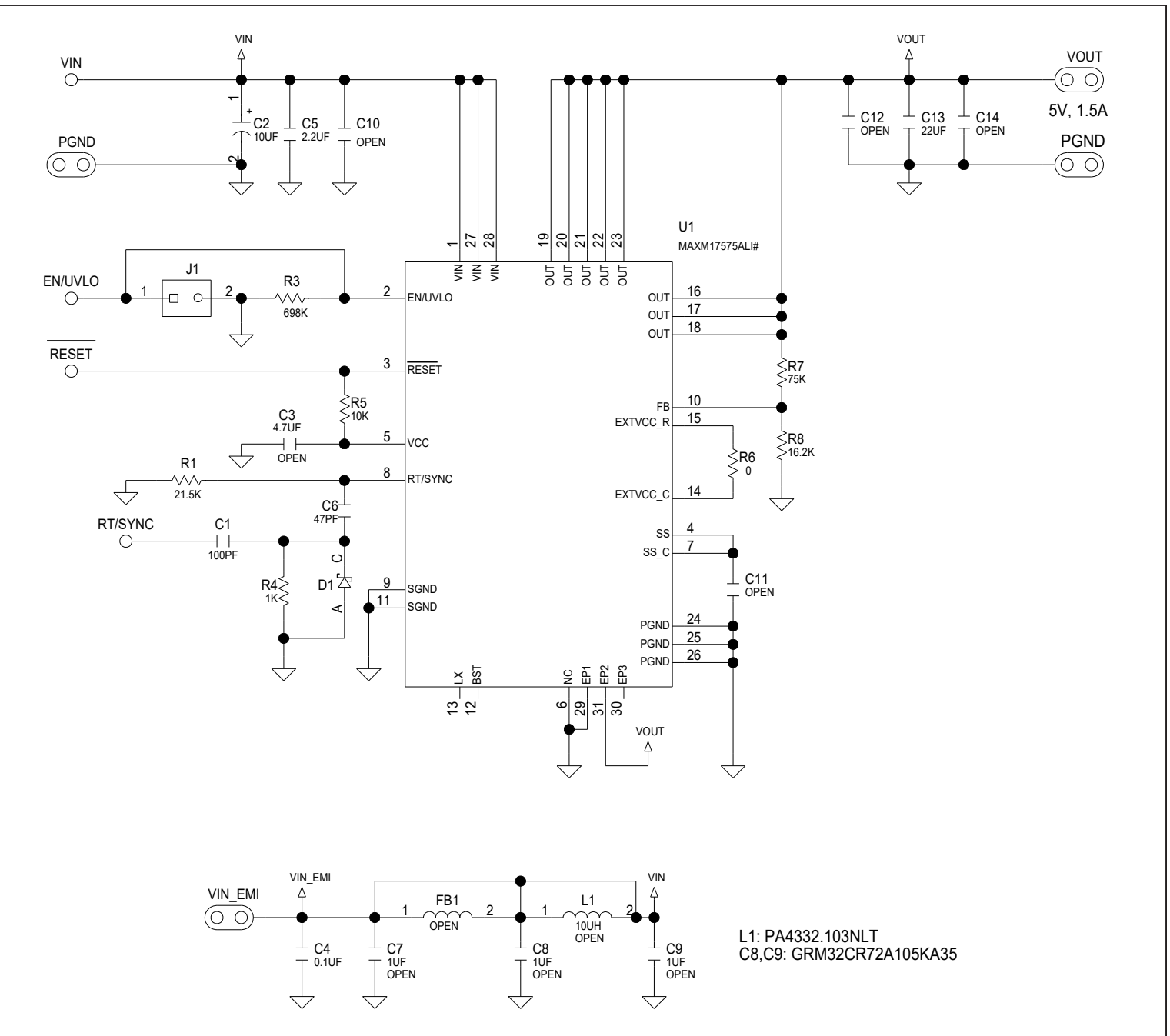

# MAXM17575 5V Output Evaluation Kit

Evaluates: MAXM17575  
5V Output Application

## MAXM17575 5V EV Kit PCB Layouts

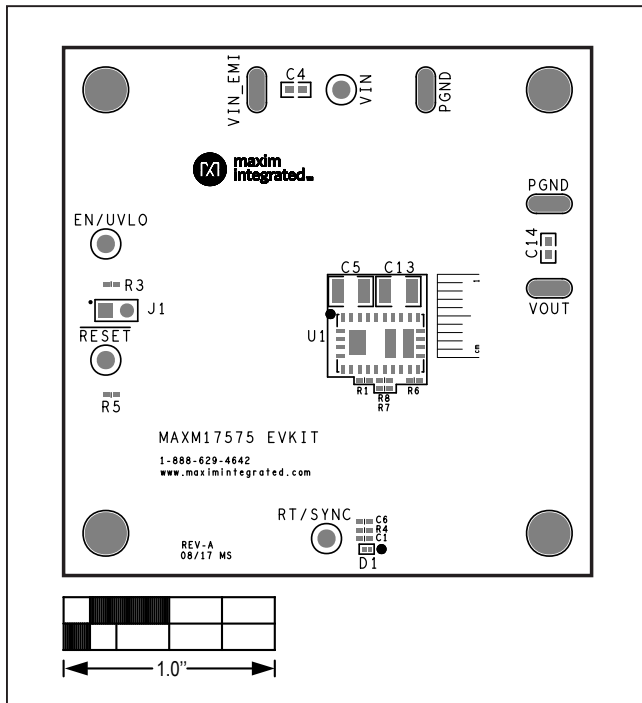

MAXM17575 5V EV Kit Component Placement Guide—  
Component Side

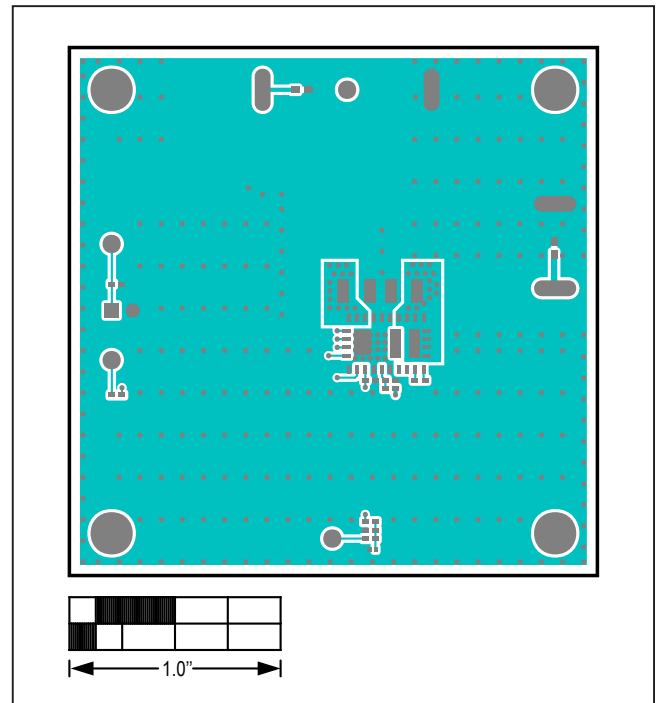

MAXM17575 5V EV Layout Top Layer

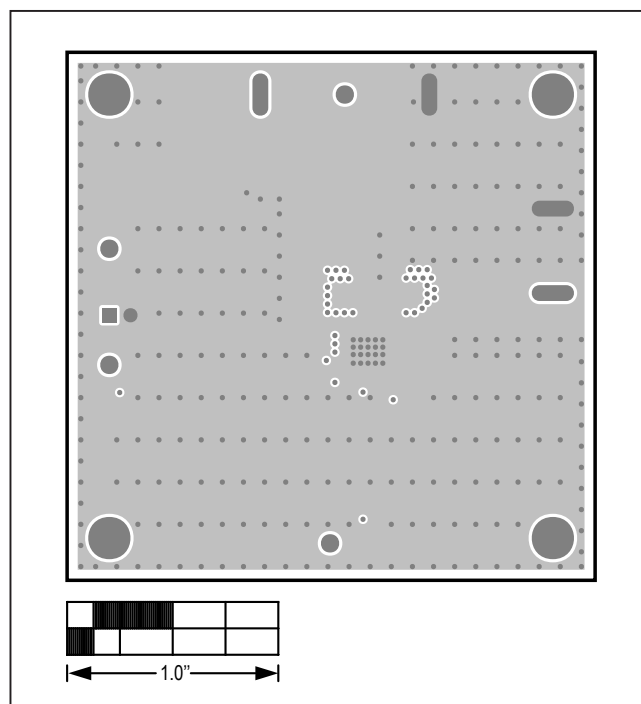

MAXM17575 5V EV Layout Layer 2



MAXM17575 EV Kit PCB Layouts (continued)

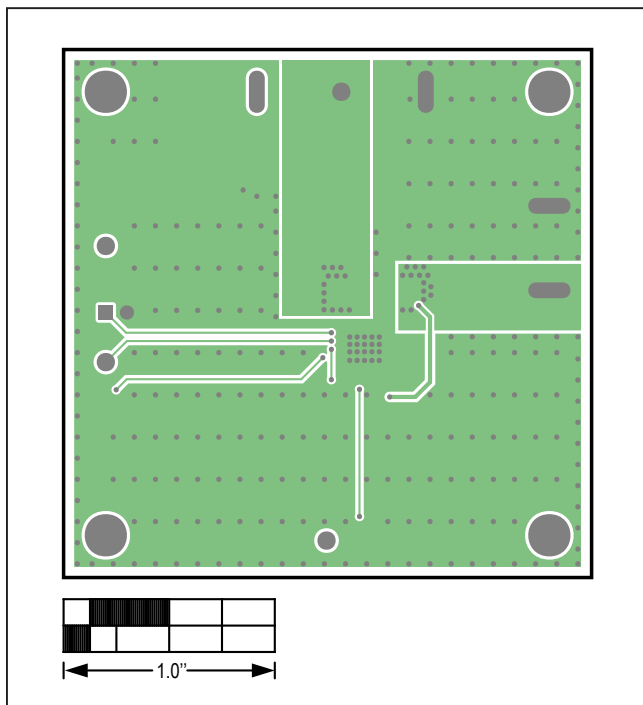

MAXM17575 5V EV Layout Layer 3

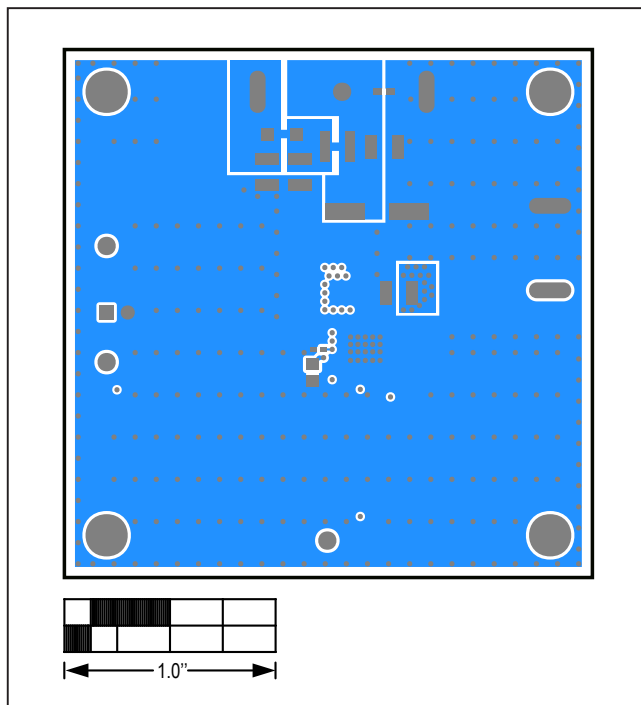

MAXM17575 5V EV Layout Bottom Layer

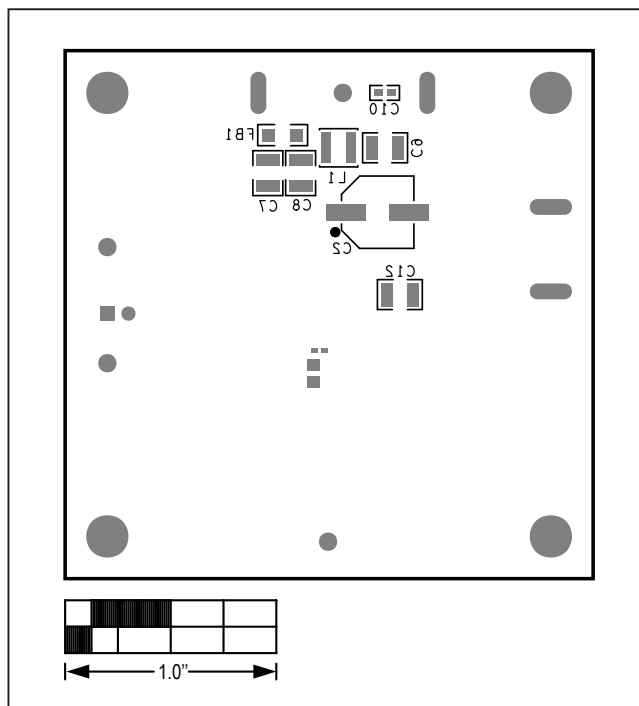

MAXM17575 5V EV Layout Bottom Silkscreen

MAXM17575 5V Output  
Evaluation Kit

Evaluates: MAXM17575  
5V Output Application

## Revision History

REVISION NUMBER	REVISION DATE	DESCRIPTION	PAGES CHANGED
0	9/17	Initial release	—

For pricing, delivery, and ordering information, please contact Maxim Direct at 1-888-629-4642, or visit Maxim Integrated's website at [www.maximintegrated.com](http://www.maximintegrated.com).

*Maxim Integrated cannot assume responsibility for use of any circuitry other than circuitry entirely embodied in a Maxim Integrated product. No circuit patent licenses are implied. Maxim Integrated reserves the right to change the circuitry and specifications without notice at any time.*