



Chipsmall Limited consists of a professional team with an average of over 10 year of expertise in the distribution of electronic components. Based in Hongkong, we have already established firm and mutual-benefit business relationships with customers from,Europe,America and south Asia,supplying obsolete and hard-to-find components to meet their specific needs.

With the principle of “Quality Parts,Customers Priority,Honest Operation,and Considerate Service”,our business mainly focus on the distribution of electronic components. Line cards we deal with include Microchip,ALPS,ROHM,Xilinx,Pulse,ON,Everlight and Freescale. Main products comprise IC,Modules,Potentiometer,IC Socket,Relay,Connector.Our parts cover such applications as commercial,industrial, and automotives areas.

We are looking forward to setting up business relationship with you and hope to provide you with the best service and solution. Let us make a better world for our industry!



## Contact us

Tel: +86-755-8981 8866 Fax: +86-755-8427 6832

Email & Skype: info@chipsmall.com Web: www.chipsmall.com

Address: A1208, Overseas Decoration Building, #122 Zhenhua RD., Futian, Shenzhen, China



# ASSP

## Dual Serial Input PLL Frequency Synthesizer

### MB15U36

#### ➤ DESCRIPTION

The Fujitsu MB15U36 is a serial input Phase Locked Loop (PLL) frequency synthesizer with 2.0GHz and 1.2GHz prescalers. A 64/65 or a 128/129 for the 2.0GHz prescaler, and a 64/65 or a 128/129 for the 1.2GHz prescaler can be selected that enables pulse swallow operation.

The latest BiCMOS process technology is used, resultantly a supply current is limited as low as 9.0mA typ. at a supply voltage of 5.0V. MB15U36 utilizes a refined charge pump design (Fujitsu's Super Charger) that provides fast tuning along with low noise performance.

MB15U36 is ideally suitable for digital mobile communications, such as CATV, PHS(Personal Handy Phone System), and PCS( Personal Communication Service).

#### ➤ FEATURE

- High frequency operation : RF synthesizer: 2.0GHz max.  
IF synthesizer: 1.2GHz max.
- Power supply voltage :  $V_{cc}=3.0V$  to 5.5V
- Very low power supply current :  $I_{cc}=9.0mA$  typ. ( $V_{cc}=5.0V$ )
- Power saving function :  $I_{ps1}=I_{ps2}=10\mu A$  max.
- Serial input 15 bit programmable reference divider :  $R=3$  to 32,767
- Serial input 18 bit programmable divider consisting of
  - Binary 7 bit swallow counter : 0 to 127
  - Binary 11 bit programmable counter : 3 to 2,047
- On-chip high performance charge pump circuit and phase comparator achieved high speed settling time and low phase noise.
- Wide operating temperature :  $T_a = -40$  to  $+85^{\circ}C$
- Plastic 20 pin TSSOP package

#### ➤ PACKAGE

20-pin Plastic SSOP

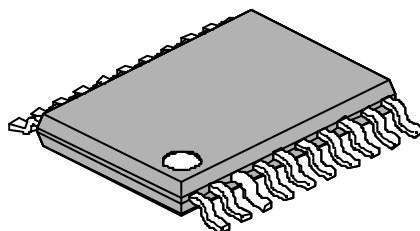

FPT-20P-M03

---

**MB15U36**

---

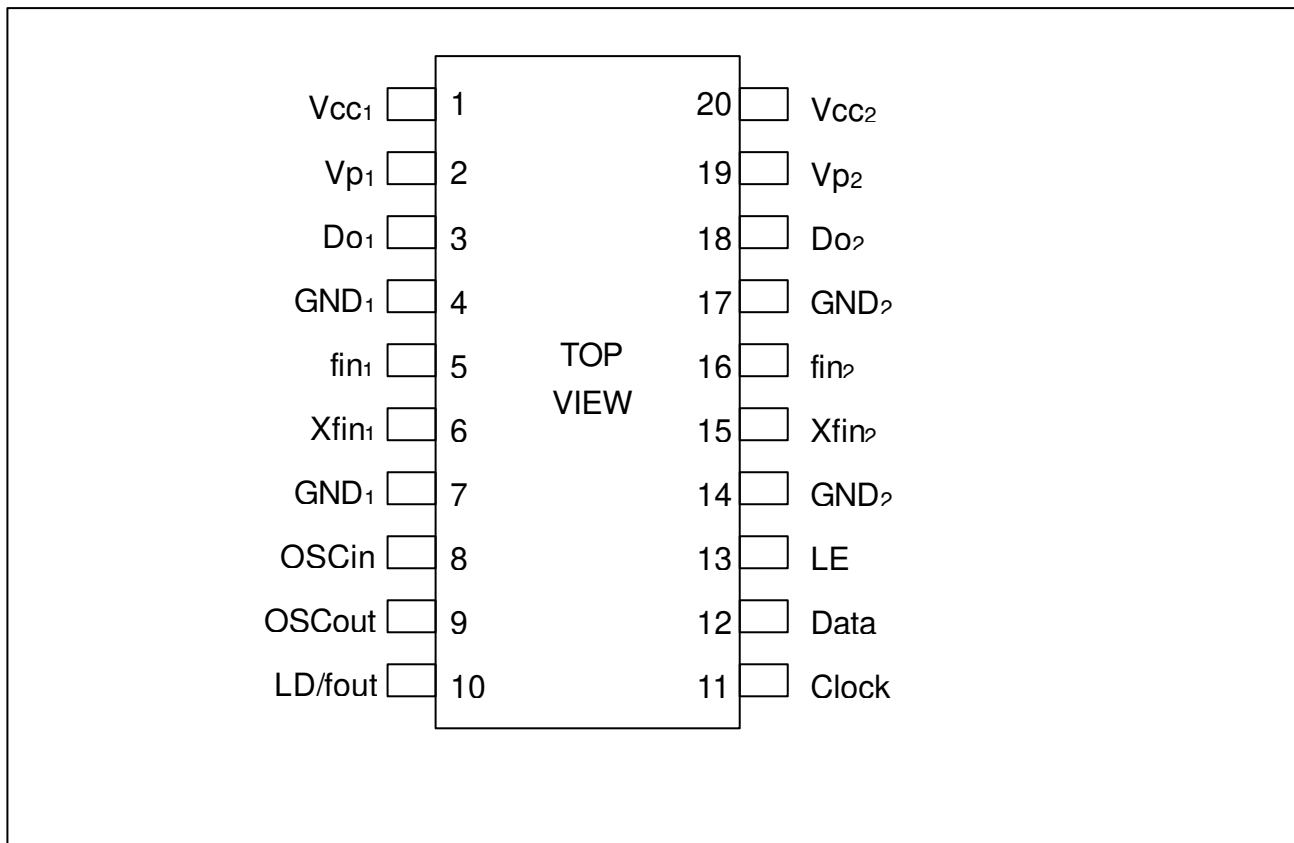
**➤ PIN ASSIGNMENT**

## MB15U36

### ➤ PIN DESCRIPTIONS

Pin No	Pin name	I/O	Descriptions
1	Vcc <sub>1</sub>	–	Power supply voltage input pin for the RF1-PLL section, the shift register and the oscillator input buffer. When power is OFF, latched data of RF1-PLL is cancelled.
2	Vp <sub>1</sub>	–	Power supply for RF1 charge pump.(Independent of 19 pin)
3	Do <sub>1</sub>	O	Charge pump output for the RF1-PLL section. Phase detector characteristics can be reversed using the FC bit.
4	GND <sub>1</sub>	–	Ground for the RF1-PLL section.
5	fin <sub>1</sub>	I	Prescaler input pin for the RF1-PLL section. Connection to an external VCO should be via AC coupling.
6	Xfin <sub>1</sub>	I	Prescaler complimentary input for the RF1-PLL. Section. This pin should be grounded via a capacitor.
7	GND <sub>1</sub>	–	Ground for the RF1-PLL section.
8	OSCin	I	The programmable reference divider input. External TCXO reference oscillator input or connection to crystal. TCXO should be connected with via AC coupling.
9	OS Cout	–	Oscillator output or connection to crystal.
10	LD/fout	O	Lock detect signal output (LD) / phase comparator monitoring output (fout). The output signal is selected by the LDS and FDS bits in the serial data.
11	Clock	I	Clock input for the 22 bit shift register. One bit data is shifted into the shift register on a rising edge of the clock.
12	Data	I	Serial data input. Data is transferred to the corresponding latch (RF1-ref counter, RF1-prog counter, RF2-ref counter, RF2-prog counter according to the control bits setting in the serial programming data.
13	LE	I	Load enable signal input. When LE is "H", data in the shift register is transferred to the corresponding latch according to the control bits in the serial programming data.
14	GND <sub>2</sub>	–	Ground for the RF2-PLL section.
15	Xfin <sub>2</sub>	I	Prescaler complimentary input for the RF2-PLL section. This pin should be grounded via a capacitor.
16	fin <sub>2</sub>	I	Prescaler input pin for the RF2-PLL section. Connection to an external VCO should be via AC coupling.
17	GND <sub>2</sub>	–	Ground for the RF2-PLL section.
18	Do <sub>2</sub>	O	Charge pump output for the RF2-PLL section. Phase detector characteristics can be reserved using FC bit.
19	Vp <sub>2</sub>	–	Power supply voltage for the RF2 charge pump.(Independent of 2 pin)
20	Vcc <sub>2</sub>	–	Power supply voltage input pin for the RF2-PLL section. When power is OFF, latched data of IF-PLL is cancelled.

# MB15U36

## ➤ BLOCK DIAGRAM

PKG:TSSOP-20(FPT-20-M03)

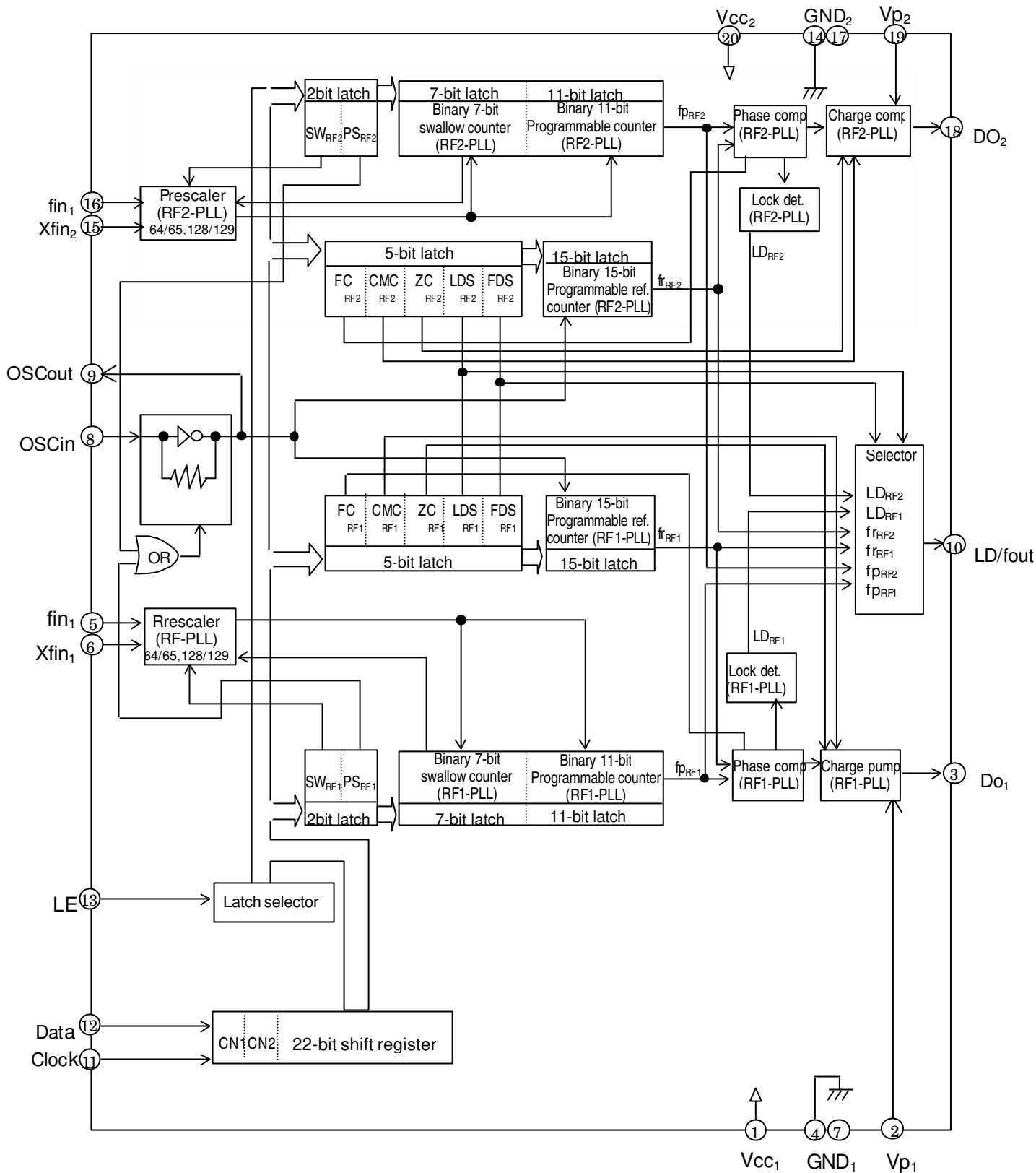

## MB15U36

### ➤ ABSOLUTE MAXIMUM

Parameter	Symbol	Rating	Unit	Remark
Power supply voltage	V <sub>cc</sub>	-0.5 to 6.5	V	
	V <sub>p</sub>	-0.5 to 6.5	V	
Input voltage	V <sub>i</sub>	-0.5 to 6.5	V	
Output voltage	V <sub>o</sub>	-0.5 to 6.5	V	
Storage temperature	T <sub>STG</sub>	-55 to +125	°C	

Note: Permanent device damage may occur if the above Absolute Maximum Ratings are exceeded. Functional operation should be restricted to the conditions as detailed in the operational sections of this data sheet. Exposure to absolute maximum rating conditions for extended periods may affect device reliability.

### ➤ RECOMMENDED OPERATING CONDITIONS

Parameter	Symbol	Value			Unit	Remark
		Min.	Typ.	Max.		
Power supply voltage	V <sub>cc</sub>	4.5	5.0	5.5	V	V <sub>cc1</sub> =V <sub>cc2</sub>
		3.0	5.5	5.5	V	V <sub>cc1</sub> =V <sub>cc2</sub> *1
	V <sub>p</sub>	V <sub>cc</sub>	-	5.5	V	
Input voltage	V <sub>i</sub>	GND	-	V <sub>cc</sub>	V	
Operating temperature	T <sub>a</sub>	-40	-	+85	°C	

\*1: Prescaler divide ratio is only 64/65 (SW="L") at RF1

#### Handling Precautions

- This device should be transported and stored in anti-static containers.
- This is a static-sensitive device ; take proper anti-ESD precautions. Ensure that personnel and equipment are properly grounded. Cover workbenches with grounded conductive mats.
- Always turn the power supply off before inserting or removing the device from its socket.
- Protect leads with a conductive sheet when handling or transporting PC boards with devices

## MB15U36

## ➤ ELECTRICAL CHARACTERISTICS

Parameter		Symbol	Condition	Value			Unit
Power supply current	I <sub>CC1</sub> * <sup>1</sup>	fin1=2000MHz fosc=12MHz	V <sub>CC</sub> =5.0V	–	6.0	–	mA
			V <sub>CC</sub> =3.0V	–	3.5	–	mA
	I <sub>CC2</sub> * <sup>2</sup>	fin2=1200MHz fosc=12MHz	V <sub>CC</sub> =5.0V	–	3.0	–	mA
			V <sub>CC</sub> =3.0V	–	2.5	–	mA
Power saving current	I <sub>PS1</sub>	V <sub>CC1</sub> current at PSbit <sub>RF1/RF2</sub> ="H"		–	0.1* <sup>3</sup>	10	μA
	I <sub>PS2</sub>	V <sub>CC2</sub> current at PSbit <sub>RF2</sub> ="H"		–	0.1* <sup>3</sup>	10	μA
Operating frequency	fin1* <sup>4</sup>	RF1-PLL		100	–	2000	MHz
	fin2* <sup>4</sup>	RF2-PLL		50	–	1200	MHz
	fosc	Min. 500mV <sub>pp</sub>		3	–	40	MHz
Input sensitivity	P <sub>fin1</sub>	RF1-PLL, 50Ω termination		-10	–	+2	dBm
		RF1-PLL, V <sub>CC</sub> =3.5V 300MHz ≤ fin ≤ 1000MHz 50Ω termination		-18	–	+2	dBm
	P <sub>fin2</sub>	RF2-PLL, 50Ω termination		-10	–	+2	dBm
	V <sub>osc</sub>			500	–	V <sub>CC</sub>	mV <sub>p-p</sub>
Input voltage	Data, Clock LE	V <sub>IH</sub>		V <sub>CC</sub> ×0.8	–	–	V
		V <sub>IL</sub>		–	–	V <sub>CC</sub> ×0.2	V
Input current	Data, Clock LE	I <sub>IH</sub> * <sup>5</sup>	V <sub>IH</sub> =V <sub>CC</sub>	-1.0	–	+1.0	μA
		I <sub>IL</sub> * <sup>5</sup>	V <sub>IH</sub> =0V <sub>CC</sub>	-1.0	–	+1.0	μA
	OSCin	I <sub>IH</sub>	V <sub>IH</sub> =V <sub>CC</sub>	0	–	+100	μA
		I <sub>IL</sub> * <sup>5</sup>	V <sub>IH</sub> =0V <sub>CC</sub>	-100	–	0	μA
Output voltage	LD/fout	V <sub>OH</sub>	I <sub>OH</sub> =-1mA	V <sub>CC</sub> -0.4	–	–	V
		V <sub>OL</sub>	I <sub>OL</sub> =1mA	–	–	0.4	V
	Do1 Do2	V <sub>DOH</sub>	I <sub>DOH</sub> =-0.5mA	V <sub>p</sub> -0.4	–	–	nA
		V <sub>DOL</sub>	I <sub>DOL</sub> =0.5mA	–	–	0.4	mA
High impedance cutoff current	Do1 Do2	I <sub>OFF</sub>	V <sub>CC</sub> =V <sub>p</sub> =5.0V 0.5V ≤ V <sub>DO</sub> ≤ V <sub>p</sub> -0.5V	–	–	3.0	nA
Output current	LD/fout	I <sub>OH</sub> * <sup>5</sup>	V <sub>CC</sub> =5.0V	–	–	-1.0	mA
		I <sub>OL</sub>	V <sub>CC</sub> =5.0V	+1.0	–	–	mA

## MB15U36

## ➤ ELECTRICAL CHARACTERISTICS (Continued)

Parameter		Symbol	Condition	Value			Unit
				MIN	TYP	MAX	
Output current	Do1 Do2	IDOH*5	Vcc=Vp=5.0V, VDOH=Vp/2 CMCbit="L", Ta=25°C	—	-1.25	—	mA
			Vcc=Vp=3.0V, VDOH=Vp/2 CMCbit="L", Ta=25°C	—	-1.00	—	mA
	IDOL	Vcc=Vp=5.0V, VDOL=Vp/2 CMCbit="L", Ta=25°C	—	1.25	—	mA	
		Vcc=Vp=3.0V, VDOL=Vp/2 CMCbit="L", Ta=25°C	—	1.00	—	mA	
	IDOH*5	Vcc=Vp=5.0V, VDOH=Vp/2 CMCbit="H", Ta=25°C	—	-5.00	—	mA	
		Vcc=Vp=3.0V, VDOH=Vp/2 CMCbit="H", Ta=25°C	—	-4.00	—	mA	
	IDOL	Vcc=Vp=5.0V, VDOL=Vp/2 CMCbit="H", Ta=25°C	—	5.00	—	mA	
		Vcc=Vp=3.0V, VDOL=Vp/2 CMCbit="H", Ta=25°C	—	4.00	—	mA	
Cp current change ratio	IDOL/IDOH	IDOMT*6	VDO=Vp/2, Ta=25°C	—	3	—	%
	IDO vs VDO	IDOVD*7	0.5V ≤ VDO ≤ Vp-0.5V Ta=25°C	—	15	—	%
	IDO vs Ta	IDOTA*8	VDO=Vp/2 -40°C ≤ Ta ≤ +85°C	—	10	—	%

\*1: Conditions: Vcc1=5.0V, Ta=25°C in locking state

\*2: Conditions: Vcc2=5.0V, Ta=25°C in locking state

\*3: Conditions: Vcc=5.0V, Ta=25°C, fosc=12.8MHz(-2dBm)

\*4: AC coupling. The minimum frequency is specified with a connecting coupling capacitor of 100pF. Please note the harmonics when using at the low frequency(<1/2 max.frequency)

\*5: The symbol "-" means direction of current flow.

\*6: Conditions: Vcc=Vp=5.0V, Ta=25°C

$$\frac{(|I_3| - |I_4|)}{(|I_3| + |I_4|)/2} \times 100\%$$

\*7: Conditions: Vcc=Vp=5.0V, Ta=25°C

$$\frac{(|I_2| - |I_1|)}{(|I_2| + |I_1|)/2} \times 100\% \text{ (Applied to each IDOL, IDOH)}$$

\*8: Conditions: Vcc=Vp=5.0V

$$\frac{(|I_{DO(85^\circ C)}| - |I_{DO(-40^\circ C)}|)}{(|I_{DO(85^\circ C)}| + |I_{DO(-40^\circ C)}|)/2} \times 100\% \text{ (Applied to each IDOL, IDOH)}$$

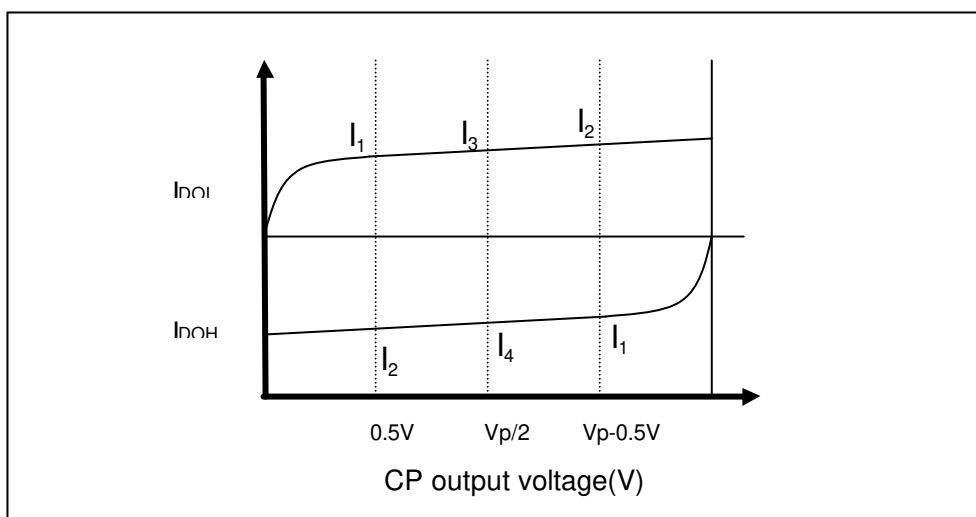



## MB15U36

### ➤ FUNCTIONAL DESCRIPTION

The divide ratio can be calculated using the following equation:

$$f_{vco} = [ ( P \times N ) + A ] \times f_{osc} / R \quad (A < N)$$

$f_{vco}$  : Output frequency of external voltage controlled oscillator (VCO)

$P$  : Preset divide ratio of dual modulus prescaler (64 or 128 for RF1-PLL or RF2-PLL)

$N$  : Preset divide ratio of binary 11-bit programmable counter (3 to 2,047)

$A$  : Preset divide ratio of binary 7-bit swallow counter ( $0 \leq A \leq 127$ )

$f_{osc}$ : Output frequency of the reference frequency oscillator

$R$  : Preset divide ratio of binary 15-bit programmable reference counter (3 to 32,767)

### Serial Data Input

Serial data is entered using three pins, Data pin, Clock pin, and LE pin. Programmable dividers of RF1/RF2-PLL sections, programmable reference dividers of IF/RF-PLL sections are controlled individually. Serial data of binary data is entered through Data pin.

On rising edge of clock, one bit of serial data is transferred into the shift register. When load enable signal is high, the data stored in the shift register is transferred to one of latch them depending upon the control bit data setting.

Table1. control Bit

Control bit		Destination of serial data
CN1	CN2	
L	L	The programmable reference counter for the RF2-PLL
L	H	The programmable reference counter for the RF1-PLL
H	L	The programmable counter and the swallow counter for the RF2-PLL
H	H	The programmable counter and the swallow counter for the RF 1-PLL

## MB15U36

### Shift Register Configuration

#### Programmable Reference Counter

LSB ↓		Data Flow →																		MSB ↓	
1	2	3	4	5	6	7	8	9	10	11	12	13	14	15	16	17	18	19	20	21	22
C	C	R	R	R	R	R	R	R	R	R	R	R	R	R	R	R	F	C	Z	L	F
N	N	1	2	3	4	5	6	7	8	9	10	11	12	13	14	15	C	M	C	D	D
1	2																C	C	S	S	S

CN1,2 :Control bit

R1 to R15 :Divide ratio setting bits for the programmable reference counter(3 to 32,767)

FC :Phase control bit for the phase detector

CMC :Charge pump output current control bit

ZC :Forced high-impedance control bit for the charge pump

LDS/FDS :LD/fout signal select bit

Note: Start data input with MSB first

#### Programmable Counter

LSB ↓		Data Flow →																		MSB ↓	
1	2	3	4	5	6	7	8	9	10	11	12	13	14	15	16	17	18	19	20	21	22
C	C	A	A	A	A	A	A	A	N	N	N	N	N	N	N	N	N	N	N	S	P
N	N	1	2	3	4	5	6	7	1	2	3	4	5	6	7	8	9	10	11	W	S
1	2																				

CN1 :Control bit

N1 to N11 :Divide ratio setting bits for the programmable counter(3 to 2,047)

A1 to A7 :Divide ratio setting bits for the swallow counter(0 to 127)

SW :Divide ratio setting bit for the prescaler  
(64/65 or 128/129 for the RF1/RF2-PLL)

PS :Power saving mode control bit

Note: Start data input with MSB first

## MB15U36

Table.2 Binary 15 bit programmable reference counter data setting

Divide ratio (R)	R 15	R 14	R 13	R 12	R 11	R 10	R 9	R 8	R 7	R 6	R 5	R 4	R 3	R 2	R 1
3	0	0	0	0	0	0	0	0	0	0	0	0	0	1	1
4	0	0	0	0	0	0	0	0	0	0	0	0	1	0	0
•	•	•	•	•	•	•	•	•	•	•	•	•	•	•	•
32767	1	1	1	1	1	1	1	1	1	1	1	1	1	1	1

Note: Divide ratio less than 3 is prohibited.

Table.3 Phase comparator phase switching data setting

	FC="H"	FC="L"
$f_r > f_p$	H	L
$f_r < f_p$	L	H
$f_r = f_p$	Z	Z
VCO polarity	(1)	(2)

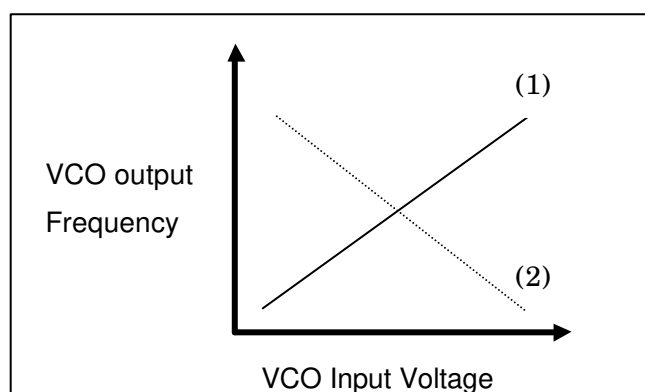

NOTE: Z= High impedance

When the LPF and VCO characteristics are similar to (1), set FC bit high

When the VCO characteristics are similar to (2), set FC bit low.

Table.4 Charge pump output current selection

CMC	Charge pump output current
0	1×IDO
1	4×IDO

Table.5 Forced high impedance control for the charge pump

ZC	Charge pump output
0	Normal output
1	High impedance

## MB15U36

Table.6 LD/fout output select data setting

LDSRF	LDSIF	RDSRF	RDSIF	LD/fout output signal
0	0	0	0	Disabled
0	1	0	0	LD signal (RF2 lock detect)
1	0	0	0	LD signal (RF1 lock detect)
1	1	0	0	LD signal (RF1/RF2 lock detect)
×	0	0	1	fout (output frRF2)
×	0	1	0	fout (output frRF1)
×	1	0	1	fout (output fpRF2)
×	1	1	0	fout (output fpRF1)
0	0	1	1	Fast lock
0	1	1	1	RF2 counter reset
1	0	1	1	RF1 counter reset
1	1	1	1	RF1/RF2 Counter reset

Note : ×=don't care

The Fast lock mode utilizes the LD/fout output pin. While Fast lock mode, whenever RF Charge pump output current select bit(CMCRF bit) is selected "H", LD/fout output pin (open drain output) is "L". When CMCRF bit is selected"L", LD/fout output pin(open drain output) is "Z".(See Fast lock circuit example)

Table.7 Binary 11 bit Programmable counter data setting

Divide ratio (N)	N 11	N 10	N 9	N 8	N 7	N 6	N 5	N 4	N 3	N 2	N 1
3	0	0	0	0	0	0	0	0	0	1	1
4	0	0	0	0	0	0	0	0	1	0	0
•	•	•	•	•	•	•	•	•	•	•	•
2047	1	1	1	1	1	1	1	1	1	1	1

Note: Divide ratio less than 3 is prohibited.

## MB15U36

Table.8 Binary 7 bit swallow counter data setting

Divide ratio (A)	A 7	A 6	A 5	A 4	A 3	A 2	A 1
0	0	0	0	0	0	0	0
1	0	0	0	0	0	0	1
•	•	•	•	•	•	•	•
127	1	1	1	1	1	1	1

Note: Divide ratio (A) range=0 to 127

Table.9 Prescaler data setting

		SW="L"	SW="H"
Prescaler divide ratio	RF2-PLL	64/65	128/129
	RF1-PLL	64/65	128/129

Table.10 Power saving mode setting(1)

PSRF2	PS RF2	RF2-PLL counters	RF1-PLL counters	OSC input buffer
H	H	OFF	OFF	OFF
L	H	ON	OFF	ON
H	L	OFF	ON	ON
L	L	ON	ON	ON

Setting a PSRF1/RF2 bit to high, RF1-PLL/RF2-PLL enters into power saving mode resultant current consumption can be limited to 10uA max.. Setting PS bit to low, power saving mode is released so that the device works normally. Allow 1us after frequency stabilization on power-up for exiting the power saving mode.(PS: "H" to "L")

Serial data can be entered during the power saving mode.

During the power saving mode, the corresponding section except for indispensable circuit for the power saving function stops working, then current consumption is reduced to 10uA per one PLL section.

At that time, the DO become the same state as when a loop is locking. That is, the DO becomes high impedance. A VCO control voltage is naturally kept at the locking voltage which defined by a time constant of LPF. As a result, VCO's frequency is kept at the locking frequency.

# MB15U36

## Serial data input timing

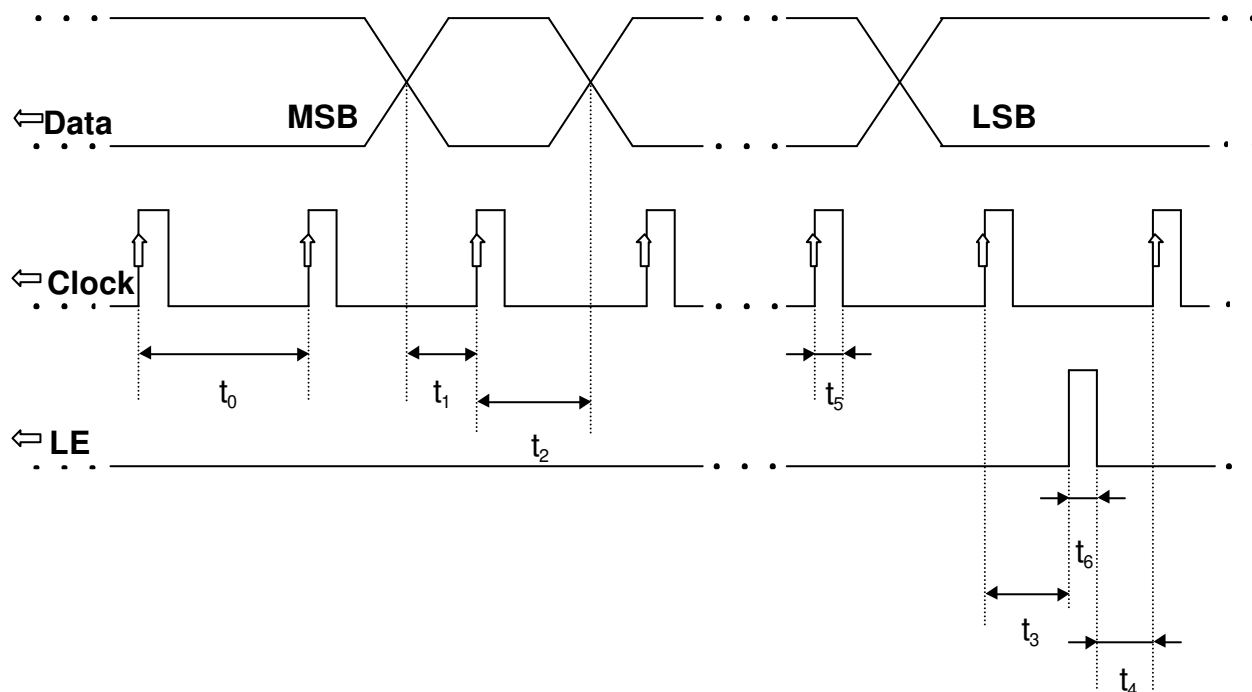

Table11. Timing parameters

Parameter	MIN.	TYP.	MAX.	Unit	Note
$t_0$	100	—	—	ns	CK Rate
$t_1$	20	—	—	ns	$t_{su} \text{ CK} \rightarrow \text{Data}$
$t_2$	20	—	—	ns	$t_{th} \text{ CK} \rightarrow \text{Data}$
$t_3$	30	—	—	ns	$t_{su} \text{ LE}$
$t_4$	20	—	—	ns	$t_{su} \text{ inactive}$
$t_5$	30	—	—	ns	$t_w \text{ CK}$
$t_6$	100	—	—	ns	$t_w \text{ LE}$

On rising edge of the clock, one bit of the data is transferred into the shift register.

# MB15U36

## ➤ Phase detector output waveform

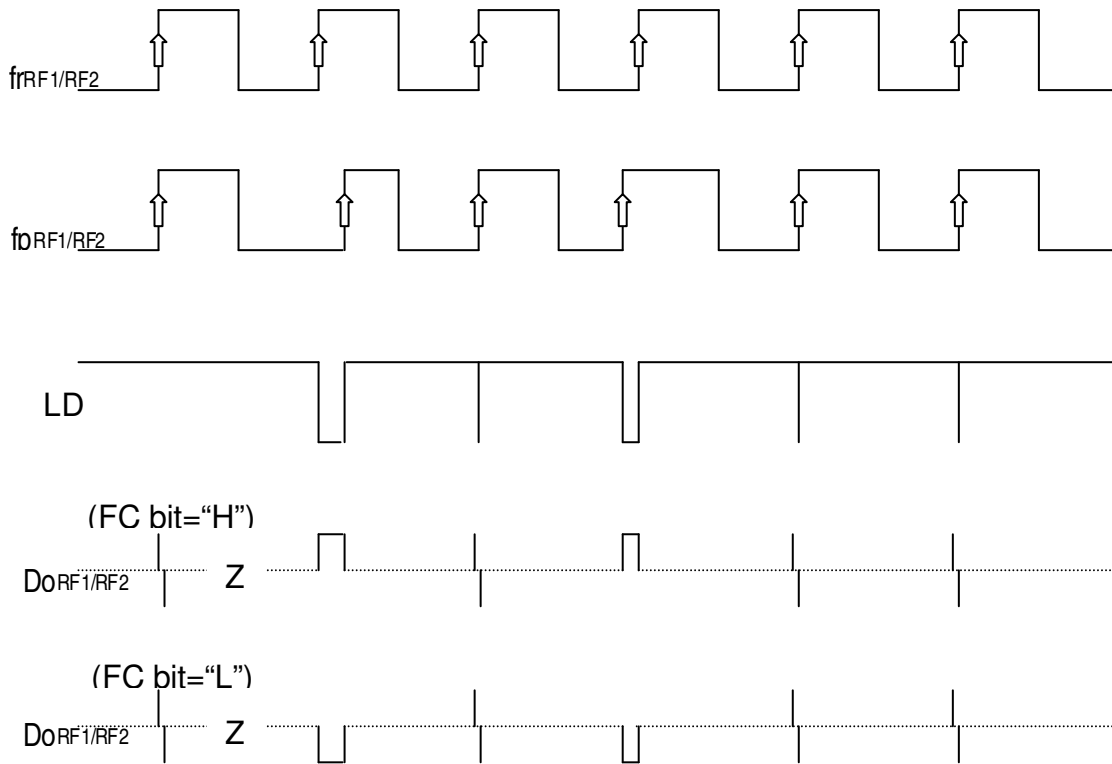

Note: Phase error detection range =  $-2\pi$  to  $+2\pi$   
 Pulse on DoRF1/RF2 signals are output to prevent dead zone.

# MB15U36

## ➤ TEST CIRCUIT (Prescaler Input/Programmable Reference Divider Input Sensitivity Test)

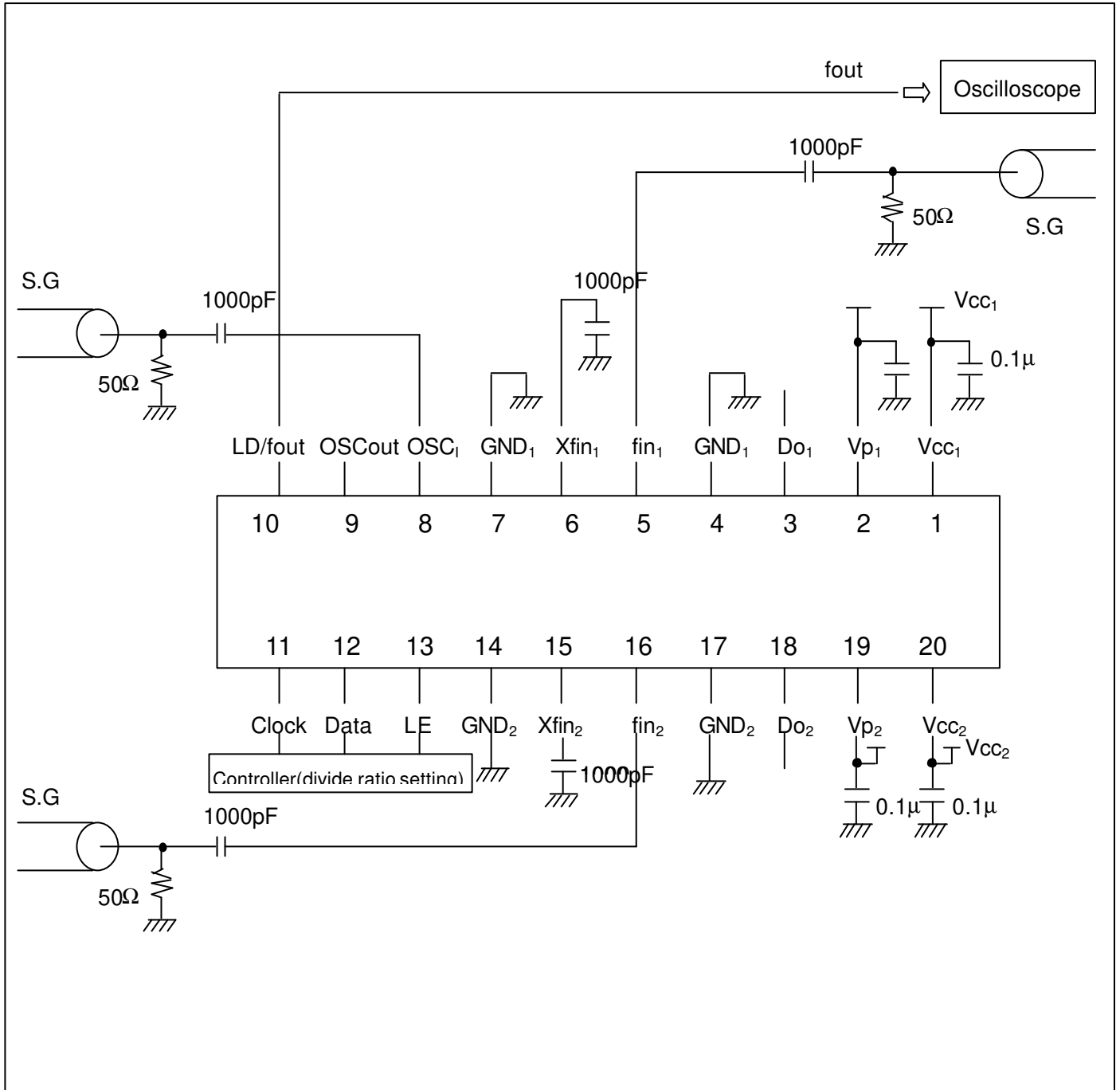



# MB15U36

## ➤ TYPICAL CHARACTERISTICS

### 1. fin input sensitivity

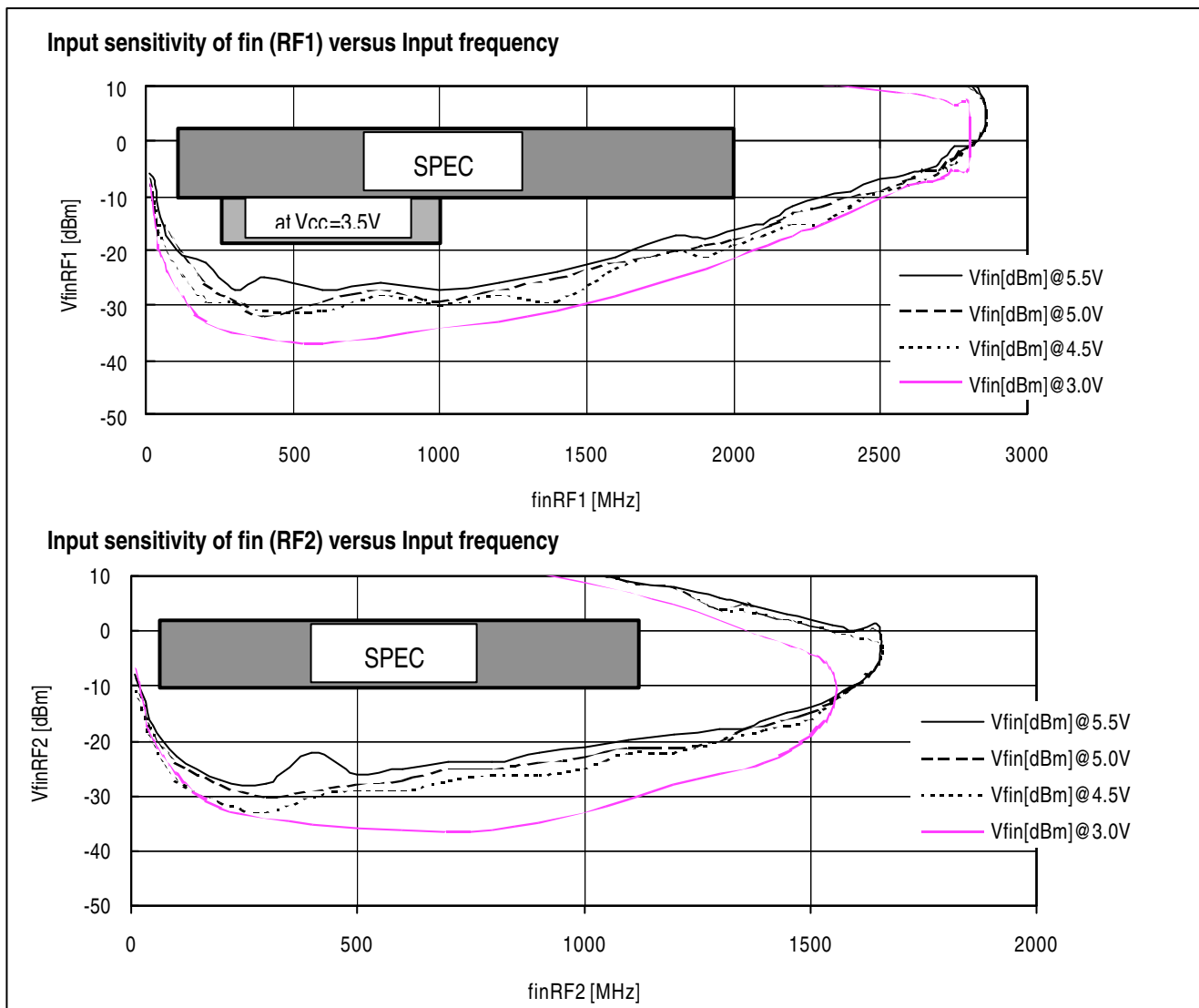

### 2. OSCin Input sensitivity

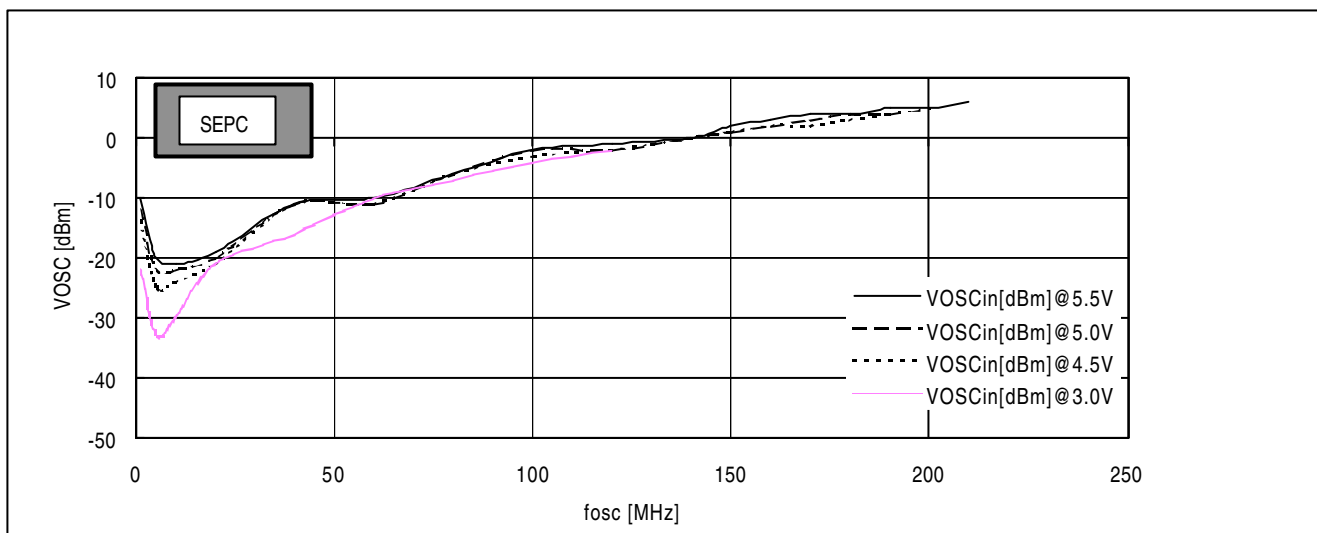

## MB15U36

## 3.Do output current (1×Do mode)

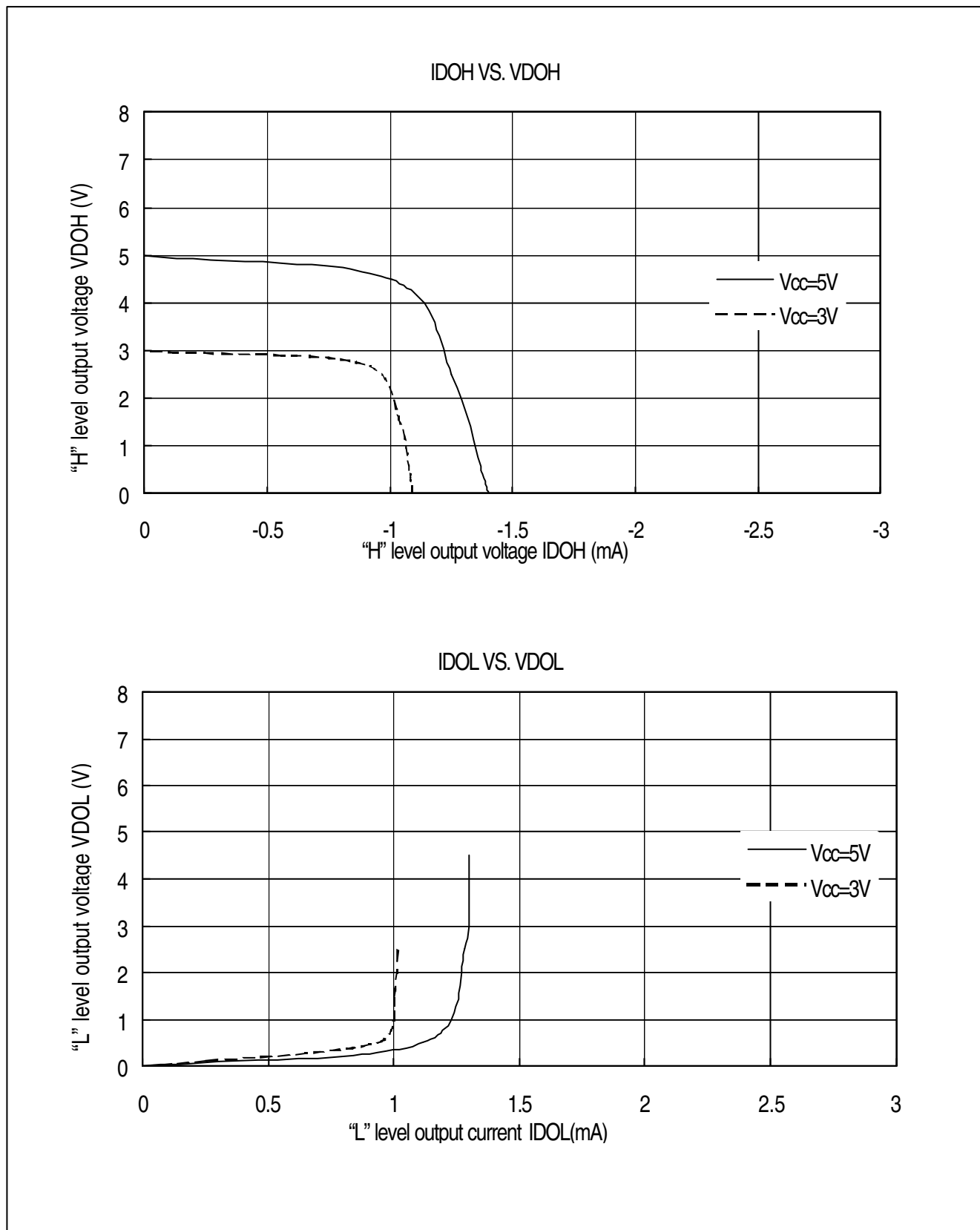

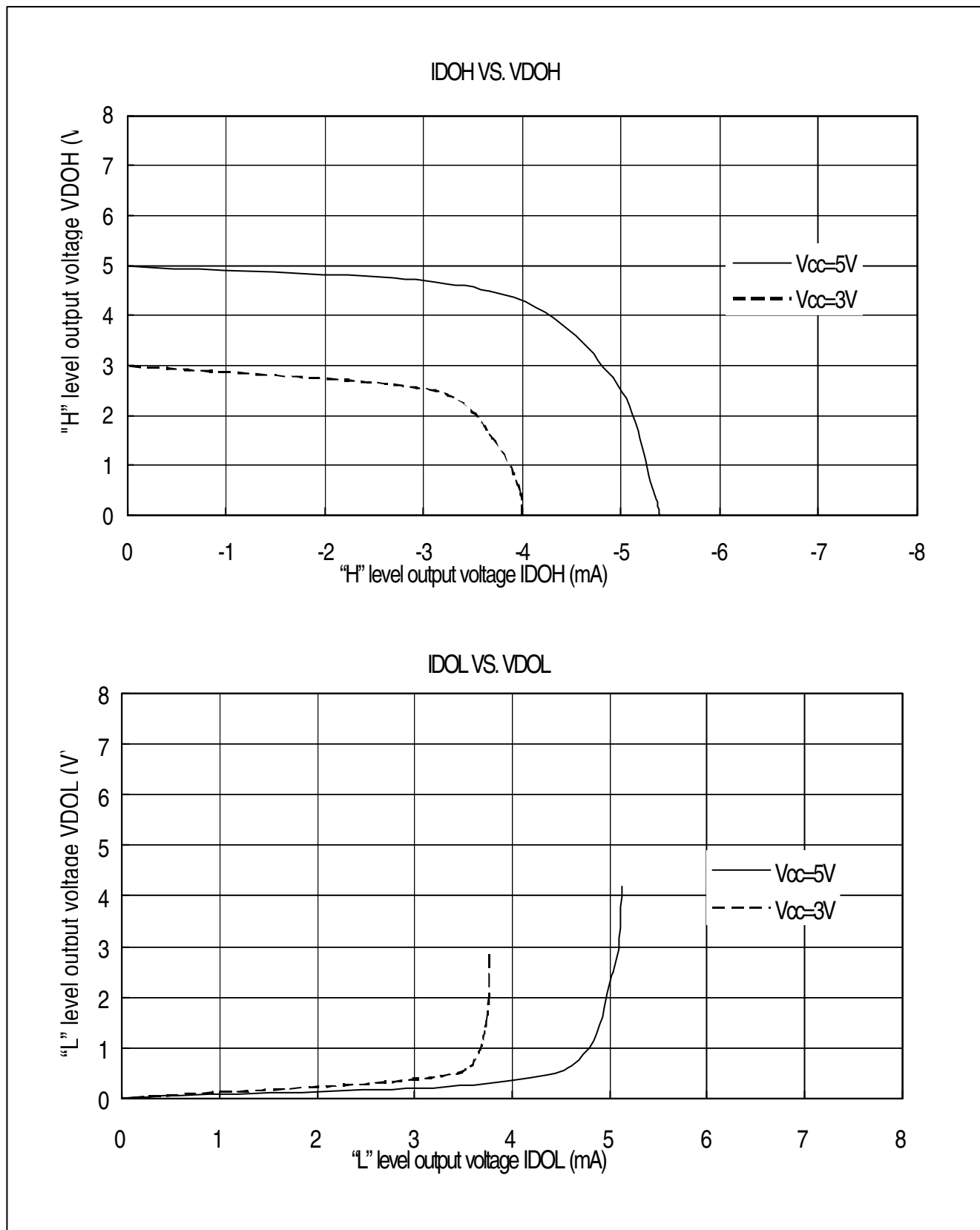
**MB15U36****4.Do output current (4×Do mode)**

# MB15U36

## 5. Input impedance

Input impedance of fin (RF1)

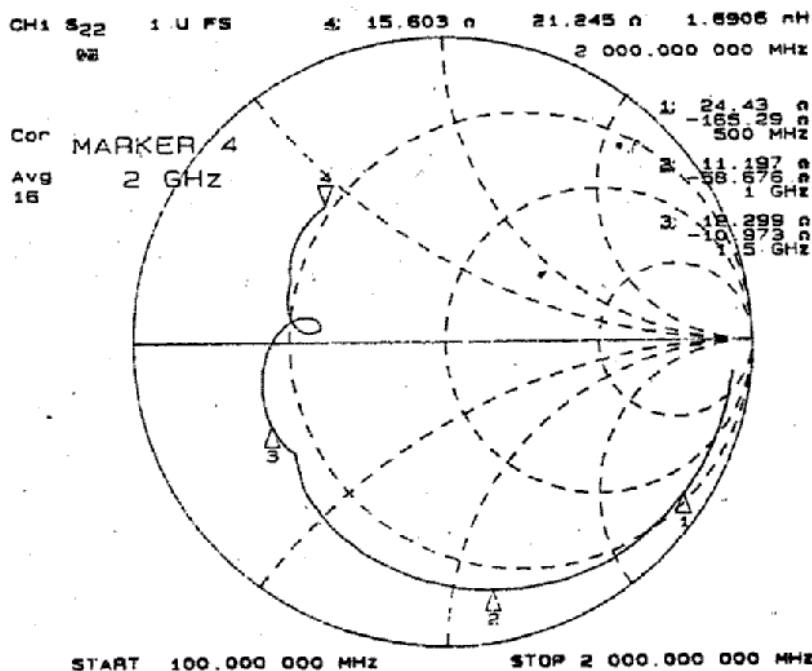

Input impedance of fin (RF2)

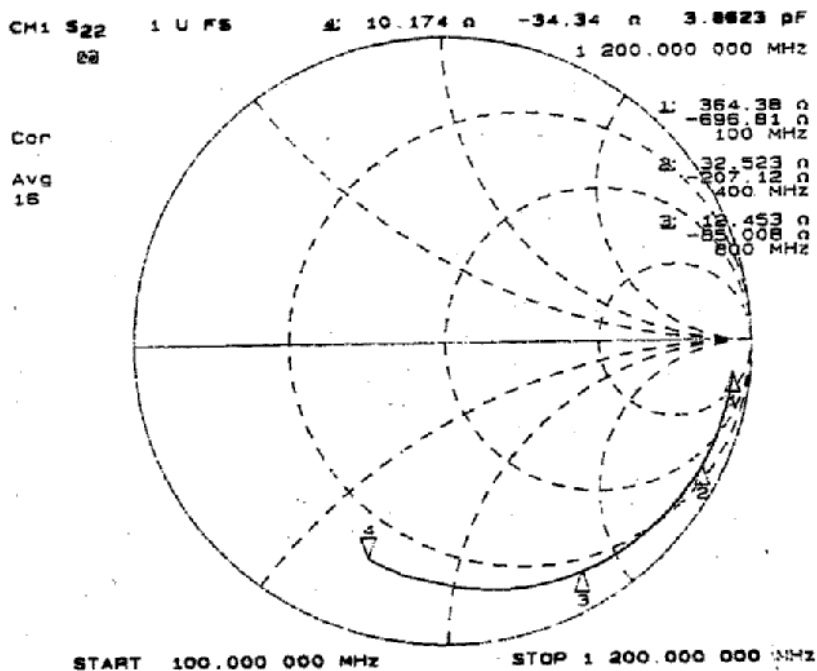

# MB15U36

## 5. Input impedance

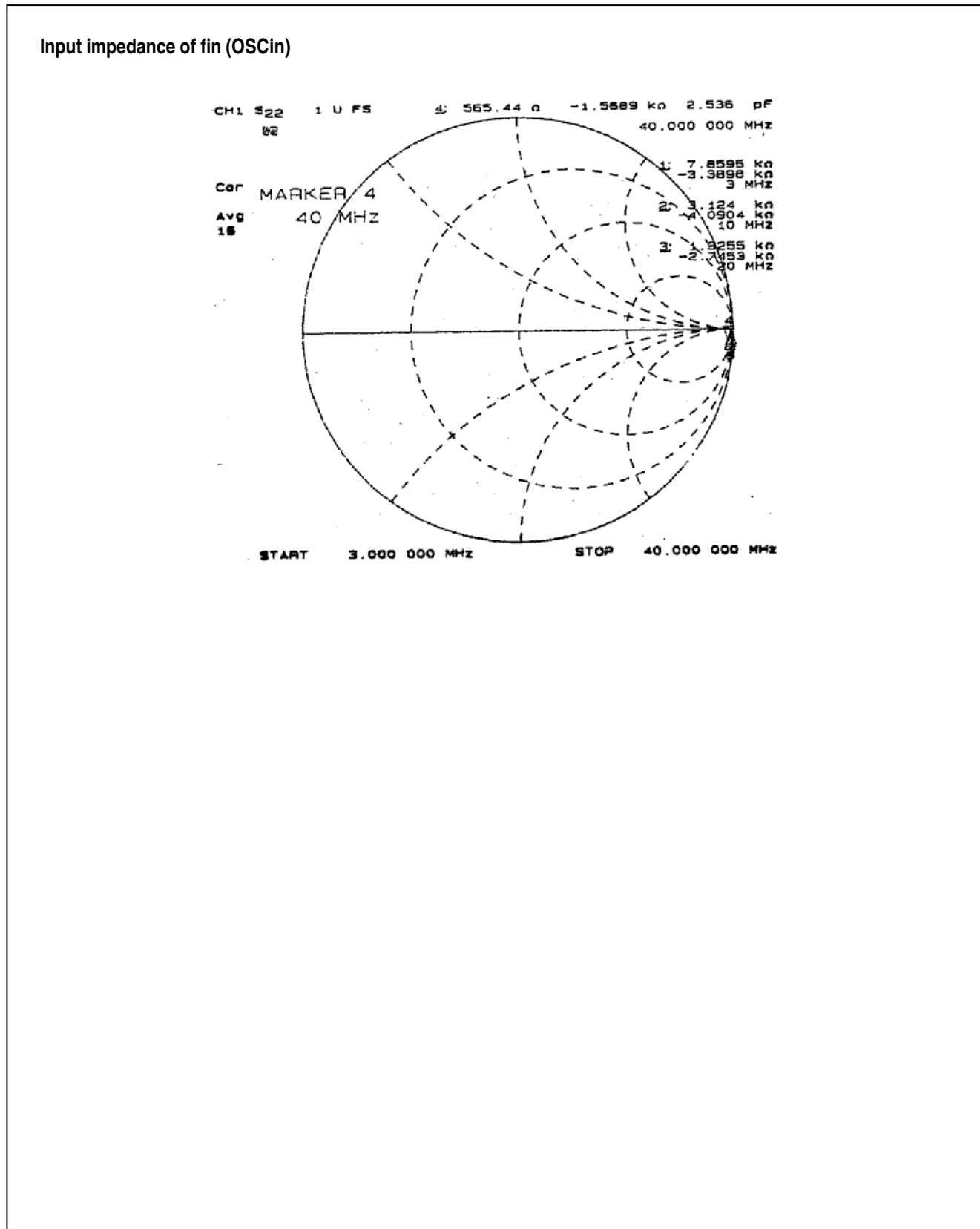

# MB15U36

## ➤ APPLICATION EXAMPLE

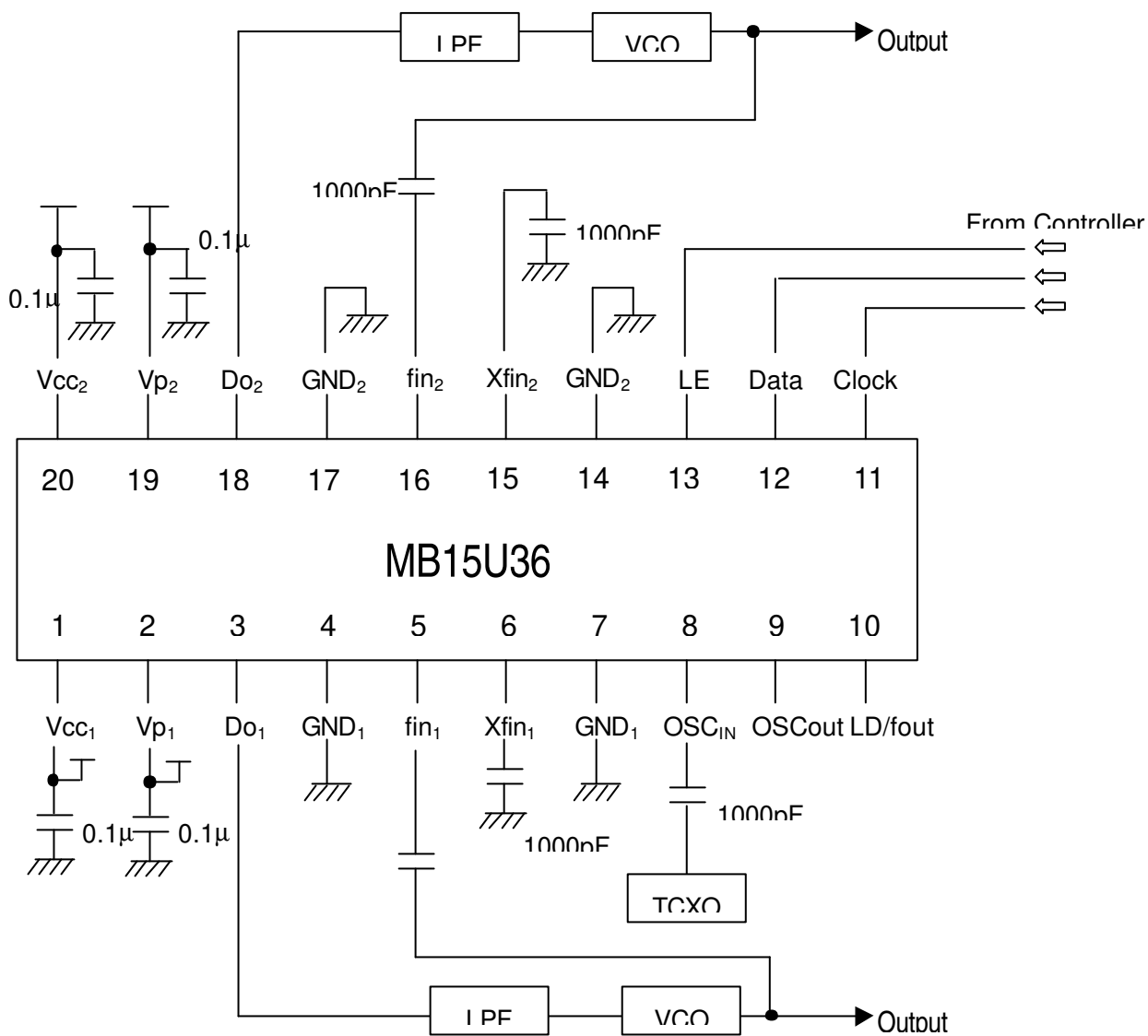

Clock, Data, LE : Insert a pull-down or pull-up resistor as needed to prevent oscillation when the terminals are left open.

## MB15U36

### ➤ APPLICATION EXAMPLE : Fast lock mode

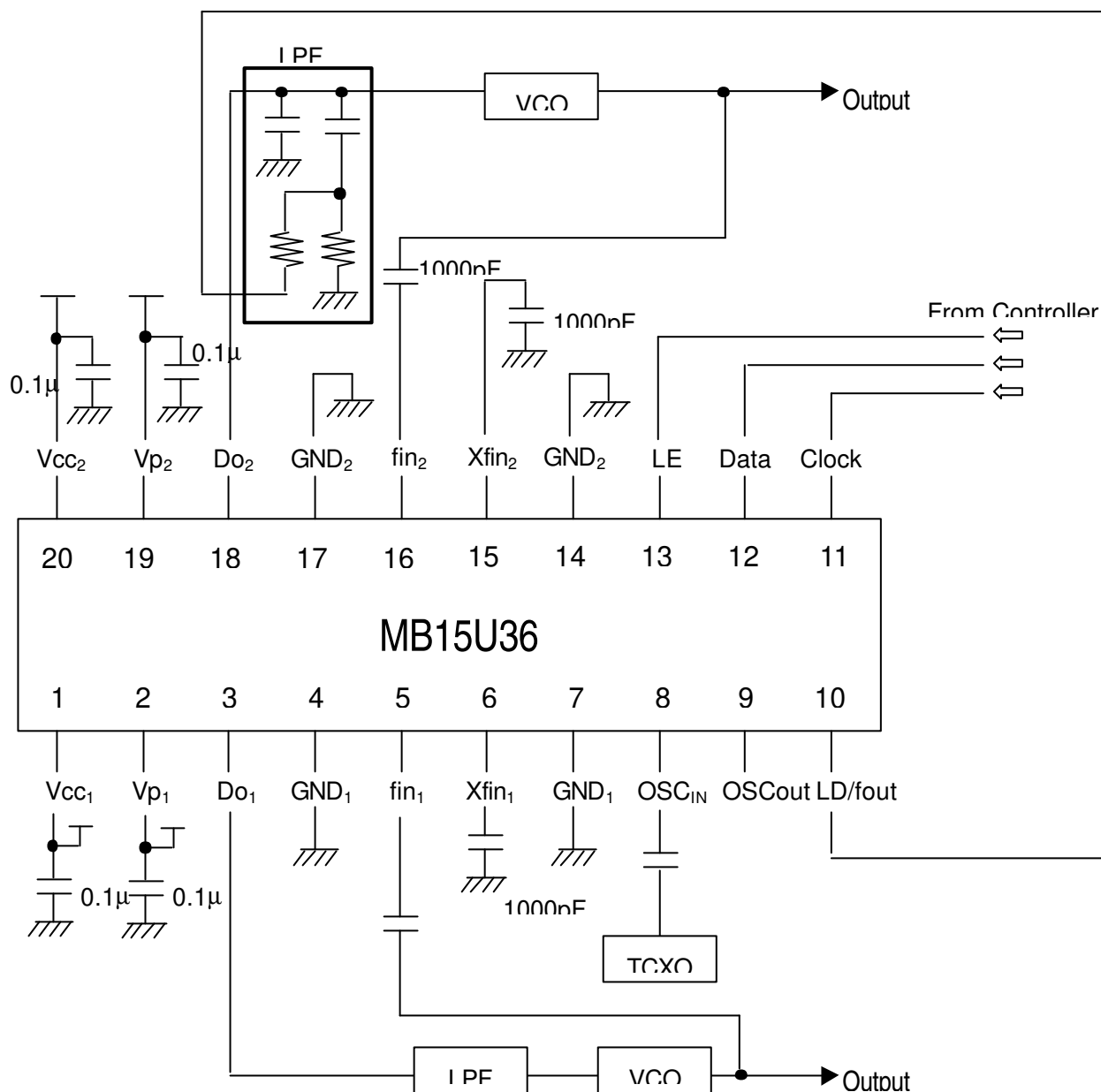

Clock, Data, LE : Insert a pull-down or pull-up resistor as needed to prevent oscillation when the terminals are left open.

The Fastlock mode is controlled by the LDS/FDS bits and the CMCRF1 bit. When the CMCRF1 bit is set to "H" (the RF1 charge pump current is increased 4x normal mode), the LD/fout pin (open drain output) is "L", enabling the parallel resistor in the loop filter. This effectively increases the LPF bandwidth, allowing the loop to lock faster. After the loop has locked onto a new frequency, the CMCRF1 bit is set to "L", forcing the LD/fout output pin into a high impedance state and returning the LPF bandwidth back to its original value.

# MB15U36

## ➤ PACKAGE DIMENSION

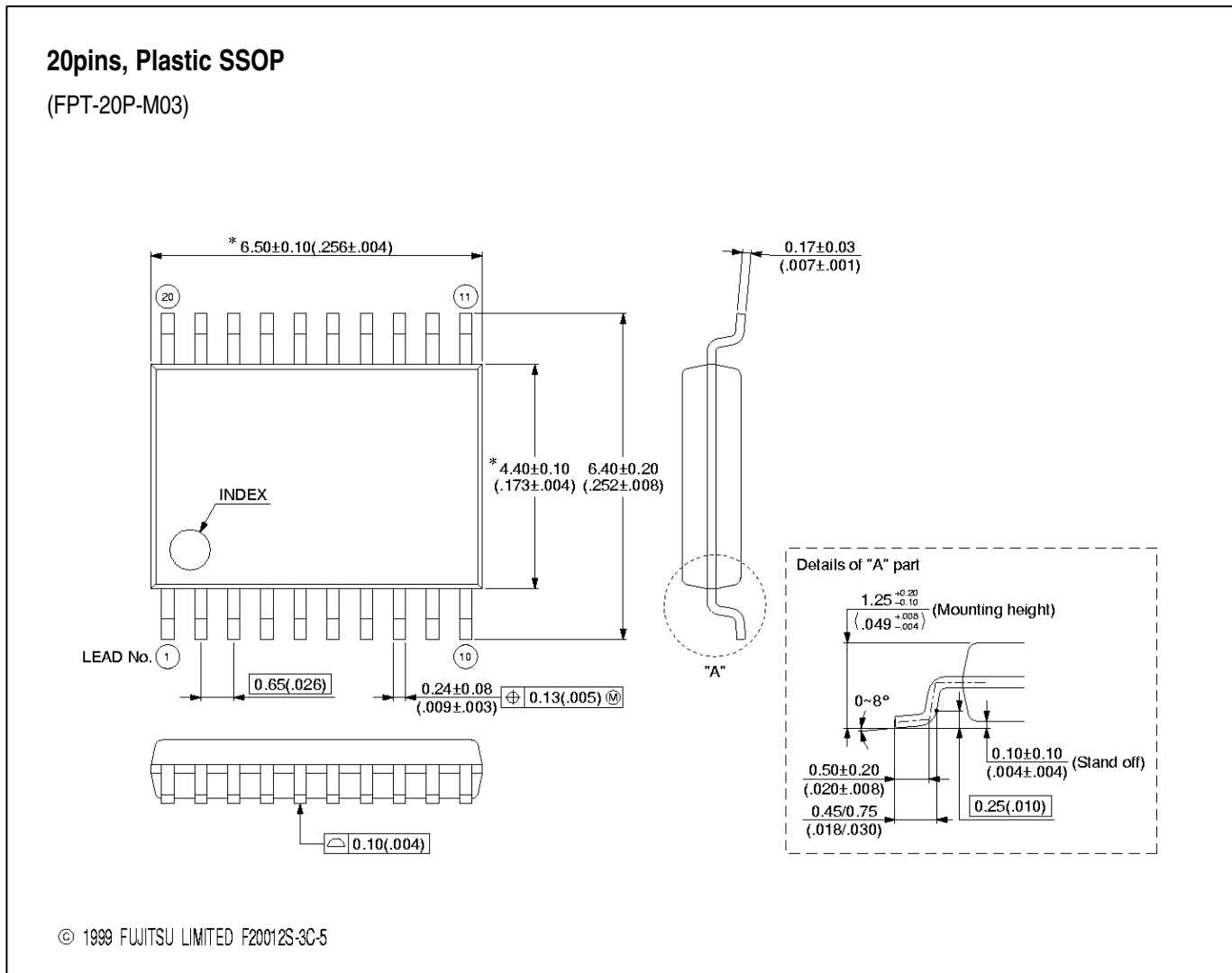

## ➤ ORDERING INFORMATION

Part number	Package	Remarks
MB15U36PFV	20pin Plastic SSOP (FPT-20P-M03)	-