

Chipsmall Limited consists of a professional team with an average of over 10 year of expertise in the distribution of electronic components. Based in Hongkong, we have already established firm and mutual-benefit business relationships with customers from,Europe,America and south Asia,supplying obsolete and hard-to-find components to meet their specific needs.

With the principle of “Quality Parts,Customers Priority,Honest Operation,and Considerate Service”,our business mainly focus on the distribution of electronic components. Line cards we deal with include Microchip,ALPS,ROHM,Xilinx,Pulse,ON,Everlight and Freescale. Main products comprise IC,Modules,Potentiometer,IC Socket,Relay,Connector.Our parts cover such applications as commercial,industrial, and automotives areas.

We are looking forward to setting up business relationship with you and hope to provide you with the best service and solution. Let us make a better world for our industry!



Contact us

Tel: +86-755-8981 8866 Fax: +86-755-8427 6832

Email & Skype: info@chipsmall.com Web: www.chipsmall.com

Address: A1208, Overseas Decoration Building, #122 Zhenhua RD., Futian, Shenzhen, China



MB3793-27D/28D/30D

Power-Voltage Monitoring IC with Watchdog Timer

Description

The MB3793 is an integrated circuit to monitor power voltage; it incorporates a watchdog timer. A reset signal is output when the power supply voltage is cut or falls instantaneously. When the power supply recovers normally after resetting, a power-on reset signal is output to monitor the power supply voltage. A built-in watchdog timer with two inputs for system operation diagnosis can provide a fail-safe function for various application systems.

Model No.	Marking Code	Detection Voltage
MB3793-27D	3793DY	2.7 V
MB3793-28D	3793DR	2.8 V
MB3793-30D	3793DC	3.0 V

Features

- Precise detection of power voltage fall: $\pm 2.5\%$
- Detection voltage with hysteresis
- Built-in dual-input watchdog timer
- Watchdog timer halt function
- Independently-set watchdog and reset times
- Open drain output
- Package : SOP

Applications

The MB3793 has various uses such as the amusement devices.

Online Design Simulation Easy DesignSim

This product supports the web-based design simulation tool. It can easily select external components and can display useful information. Please access from the following URL.

cypress.transim.com/login.aspx

Contents

Description	1
Features	1
Applications	1
1. Pin Assignment	3
2. Pin Description	3
3. Block Diagram	4
4. Block Functions	5
5. Absolute Maximum Ratings	6
6. Recommended Operating Conditions	6
7. Electrical Characteristics	7
7.1 DC Characteristics.....	7
7.2 AC Characteristics.....	8
8. Timing Diagram	9
9. Operation Sequence	14
10. Typical Characteristics	16
11. Application Example	19
12. Usage Precaution	21
13. Ordering Information	21
14. RoHS Compliance Information	21
15. Package Dimensions	22
Document History	23
Sales, Solutions, and Legal Information	24

1. Pin Assignment

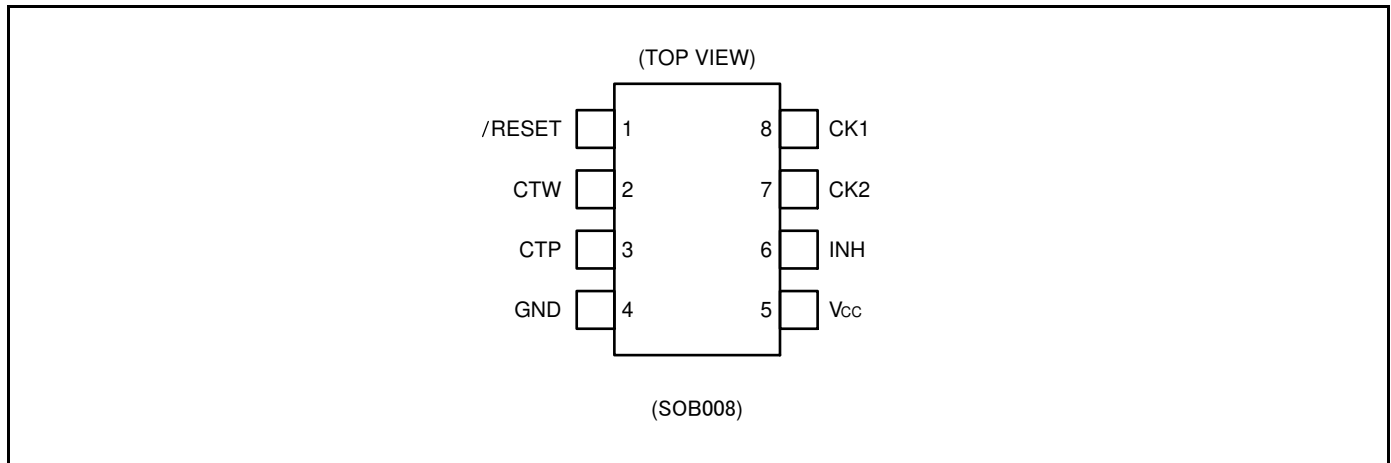

2. Pin Description

Pin No.	Symbol	Description
1	/RESET	Reset output pin (Open drain)
2	CTW	Watchdog timer monitoring time setting pin
3	CTP	Power-on reset hold time setting pin
4	GND	Ground pin
5	V _{CC}	Power supply pin
6	INH	This pin forces the watchdog timer on/off. When setting this pin to the High level, the watchdog timer is stopped.
7	CK2	Clock 2 input pin
8	CK1	Clock 1 input pin

3. Block Diagram

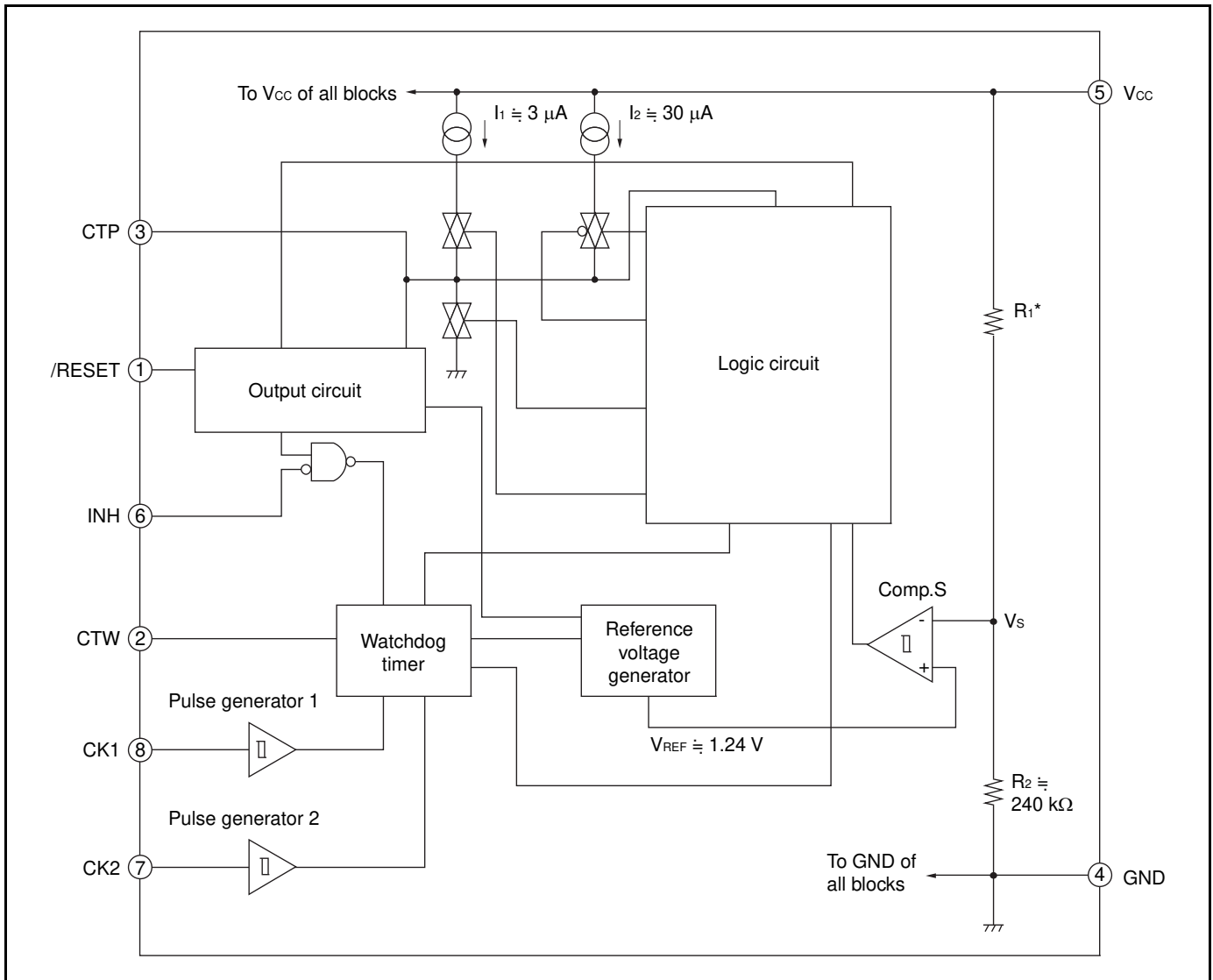

*: See the following table.

Model No.	Resistance Value (R ₁)
MB3793-27D	295 kΩ
MB3793-28D	315 kΩ
MB3793-30D	360 kΩ

4. Block Functions

Comp.S

Comp.S is a comparator with hysteresis to compare the reference voltage with a voltage (V_S) that is the result of dividing the power supply voltage (V_{CC}) by resistors R1 and R2. When V_S falls below 1.24 V, a reset signal is output. This function enables the MB3793 to detect an abnormality within 1 μ s when the power supply is cut or falls instantaneously.

Output Circuit

The output circuit has a comparator to control the reset signal (/RESET) output. When the voltage at the CTP pin for setting the power-on reset hold time exceeds the threshold voltage, resetting is canceled.

Pulse Generator

The pulse generator generates pulses when the voltage at the CK1 and CK2 input clock pins changes from Low level to High level (positive-edge trigger) and exceeds the threshold voltage; it sends the clock signal to the watchdog timer.

Watchdog Timer

The watchdog timer can monitor two clock pulses. Short-circuit the CK1 and CK2 clock pins to monitor a single clock pulse.

Logic Circuit

The logic circuit controls charging and discharging of the power-on reset hold time setting capacity (C_{TP}) on a signal of Comp.S and Watchdog timer.

5. Absolute Maximum Ratings

Parameter	Symbol	Conditions	Rating		Unit	
			Min	Max		
Power supply voltage(*1)	V_{CC}	—	-0.3	+7.0	V	
/RESET pin voltage	$V_{/RESET}$	—	-0.3	+7.0	V	
Input voltage(*1)	CK1	V_{CK1}	—	$V_{CC} + 0.3$ ($\leq +7$)	V	
	CK2	V_{CK2}	—			
	INH	V_{INH}	—			
/RESET output voltage(*1)	/RESET	V_{OL} , $V_{OH}(*2)$	—	-0.3	+7.0	V
/RESET output current		I_{OL}	—	0	+10	mA
Power dissipation	P_D	$T_a \leq +85\text{ }^\circ\text{C}$	—	200	mW	
Storage temperature	T_{stg}	—	-55	+125	$^\circ\text{C}$	

*1: The voltage is based on the ground voltage (0 V).

*2: The /RESET output voltage V_{OH} is the applied voltage to the pull-up resistor.

WARNING:

- Semiconductor devices may be permanently damaged by application of stress (including, without limitation, voltage, current or temperature) in excess of absolute maximum ratings. Do not exceed any of these ratings.

6. Recommended Operating Conditions

Parameter	Symbol	Conditions	Value			Unit
			Min	Typ	Max	
Power supply voltage	V_{CC}	—	1.2	3.3	4.0	V
/RESET pin voltage	$V_{/RESET}$	—	0	—	4.0	V
Reset (/RESET) output current	I_{OL}	—	0	—	+ 5	mA
Power-on reset hold time setting capacity	C_{TP}	—	0.001	0.1	10	μF
Watchdog timer monitoring time setting capacity (*1)	C_{TW}	—	0.001	0.01	1	μF
Operating ambient temperature	T_a	—	-40	+25	+85	$^\circ\text{C}$

*1: The watchdog timer monitor time range depends on the rating of the setting capacitor.

WARNING:

- The recommended operating conditions are required in order to ensure the normal operation of the semiconductor device. All of the device's electrical characteristics are warranted when the device is operated under these conditions.
- Any use of semiconductor devices will be under their recommended operating condition.
- Operation under any conditions other than these conditions may adversely affect reliability of device and could result in device failure.
- No warranty is made with respect to any use, operating conditions or combinations not represented on this data sheet. If you are considering application under any conditions other than listed herein, please contact sales representatives beforehand.

7. Electrical Characteristics

7.1 DC Characteristics

($V_{CC} = +3.3\text{ V}$, $T_a = +25^\circ\text{C}$)

Parameter		Symbol	Conditions		Value			Unit		
					Min	Typ	Max			
Power supply current	MB3793-27D	I_{CC1}	After exit from reset		—	38	50	μA		
	MB3793-28D				—	30	50	μA		
	MB3793-30D				—	33	48	μA		
Detection voltage	MB3793-27D	V_{SL}	V_{CC} falling	$T_a = +25^\circ\text{C}$	2.63	2.70	2.77	V		
				$T_a = -40^\circ\text{C}$ to $+85^\circ\text{C}$	2.59(*1)	2.70	2.81(*1)	V		
		V_{SH}	V_{CC} rising	$T_a = +25^\circ\text{C}$	2.69	2.76	2.83	V		
				$T_a = -40^\circ\text{C}$ to $+85^\circ\text{C}$	2.65(*1)	2.76	2.87(*1)	V		
	MB3793-28D	V_{SL}	V_{CC} falling	$T_a = +25^\circ\text{C}$	2.73	2.80	2.87	V		
				$T_a = -40^\circ\text{C}$ to $+85^\circ\text{C}$	2.69(*1)	2.80	2.81(*1)	V		
		V_{SH}	V_{CC} rising	$T_a = +25^\circ\text{C}$	2.80	2.87	2.94	V		
				$T_a = -40^\circ\text{C}$ to $+85^\circ\text{C}$	2.76(*1)	2.87	2.98	V		
	MB3793-30D	V_{SL}	V_{CC} falling	$T_a = +25^\circ\text{C}$	2.93	3.00	3.07	V		
				$T_a = -40^\circ\text{C}$ to $+85^\circ\text{C}$	2.89(*1)	3.00	3.11(*1)	V		
		V_{SH}	V_{CC} rising	$T_a = +25^\circ\text{C}$	3.00	3.07	3.14	V		
				$T_a = -40^\circ\text{C}$ to $+85^\circ\text{C}$	2.96(*1)	3.07	3.18(*1)	V		
Detection voltage hysteresis width	MB3793-27D	V_{SHYS}	$V_{SH} - V_{SL}$		35	80	120	mV		
	MB3793-28D				25	70	100	mV		
	MB3793-30D				30	70	110	mV		
CK input threshold voltage					V_{CIH}	—	1.4(*1)	1.9	2.5	V
					V_{CIL}	—	0.8	1.3	1.8(*1)	V
CK input hysteresis width					V_{CHYS}	—	0.4(*1)	0.6	0.8(*1)	V
INH input voltage					V_{IIH}	CK Rise	3.5	—	V_{CC}	V
					V_{IIL}	CK Fall	0	—	0.8	V
Logic input current (CK1,CK2,INH)					I_{IH}	$V_{IH} = V_{CC}$	—	0	1.0	μA
					I_{IL}	$V_{IL} = 0\text{ V}$	-1.0	0	—	μA
Reset output voltage	V_{OL}		$I_{/RESET} = +5\text{ mA}$		—	0.12	0.40	V		
Reset output minimum power supply voltage	V_{CCL}		$I_{/RESET} = +50\ \mu\text{A}$		—	0.8	1.2	V		
Cut off current	I_{off}		$V_{/RESET} = 6.0\text{ V}$		—	—	1	μA		

*1: This parameter is guaranteed by design, which is not supported by a final test.

7.2 AC Characteristics

($V_{CC} = +3.3\text{ V}$, $T_a = +25^\circ\text{C}$)

Parameter	Symbol	Conditions	Value			Unit
			Min	Typ	Max	
Power-on reset hold time	t_{PR}	$C_{TP} = 0.1\ \mu\text{F}$	30	75	120	ms
Watchdog timer monitoring time	t_{WD}	$C_{TW} = 0.01\ \mu\text{F}$, $C_{TP} = 0.1\ \mu\text{F}$	8	16	24	ms
Watchdog timer reset time	t_{WR}	$C_{TP} = 0.1\ \mu\text{F}$	2	5.5	9	ms
CK input pulse width	t_{CKW}	—	500	—	—	ns
CK input pulse cycle	t_{CKT}	—	20	—	—	μs
Reset falling time	T_f (*1)	$C_L = 50\ \text{pF}$, Pull-up $470\ \text{k}\Omega$	—	—	500	ns

*1: The voltage range is 10% to 90% at testing the reset output transition time.

8. Timing Diagram

Figure 8-1 Basic Operation (Positive Clock Pulse)

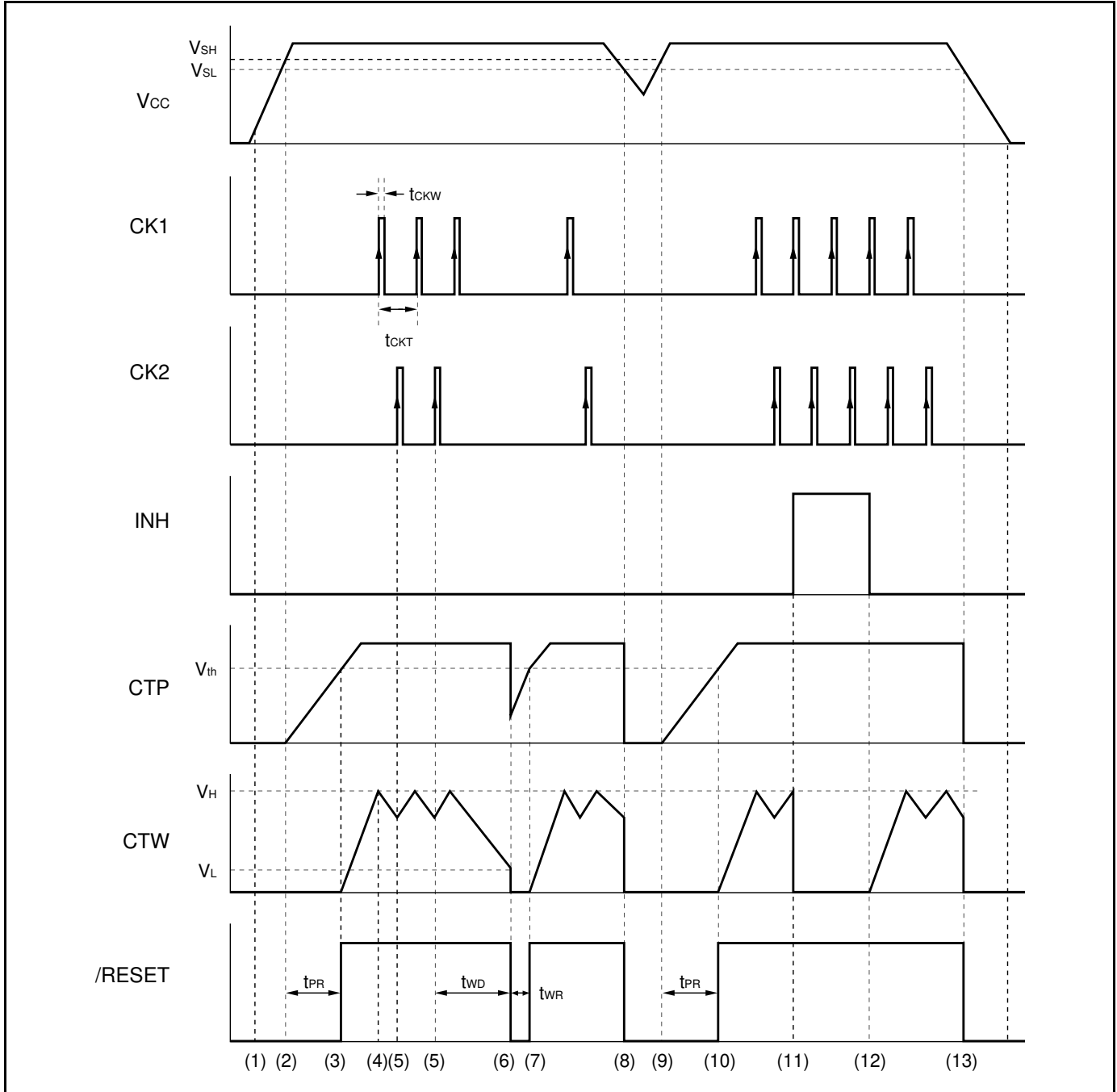

Figure 8-2 Basic Operation (Negative Clock Pulse)

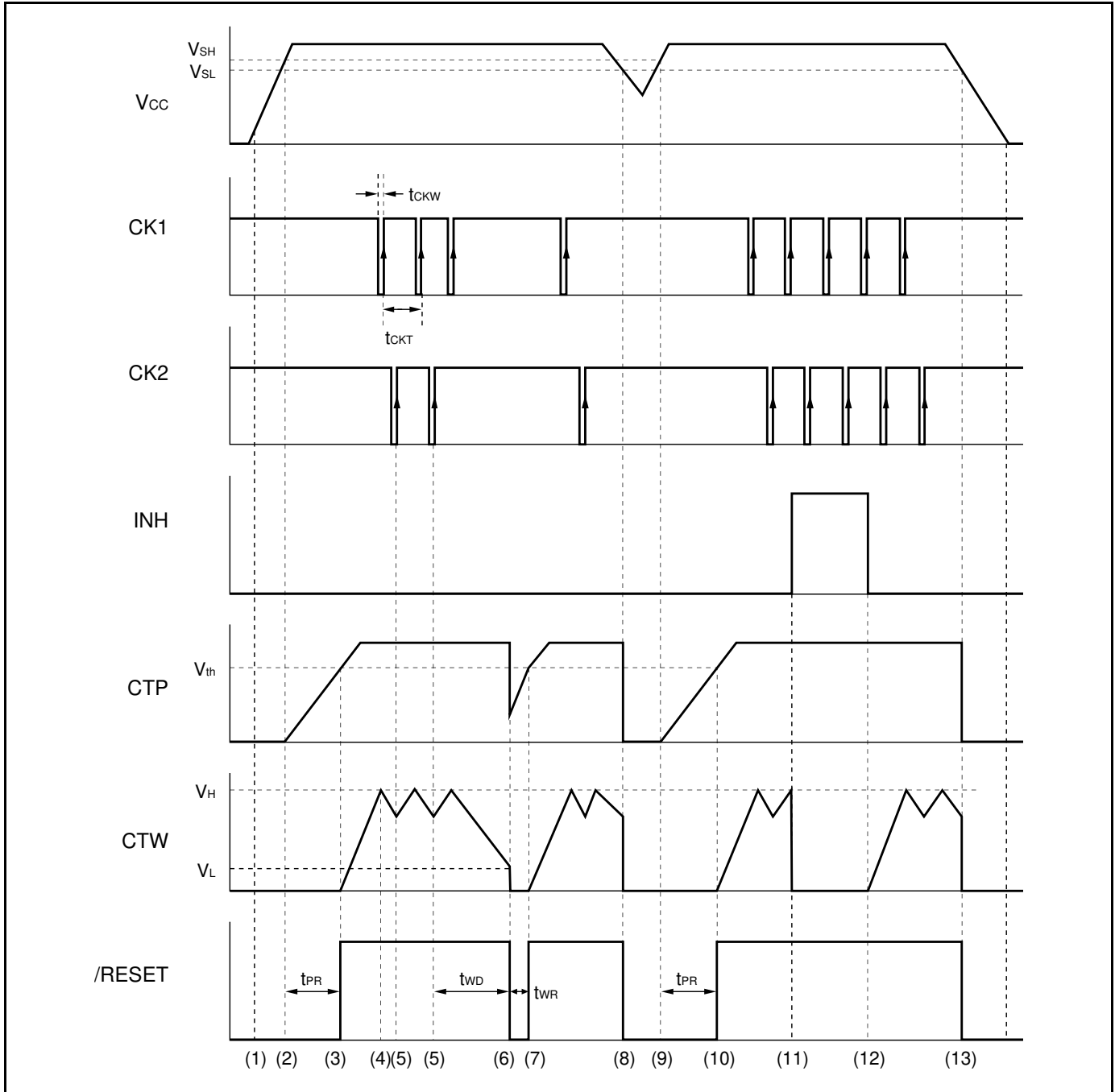

Figure 8-3 Single-clock Input Monitoring (Positive Clock Pulse)

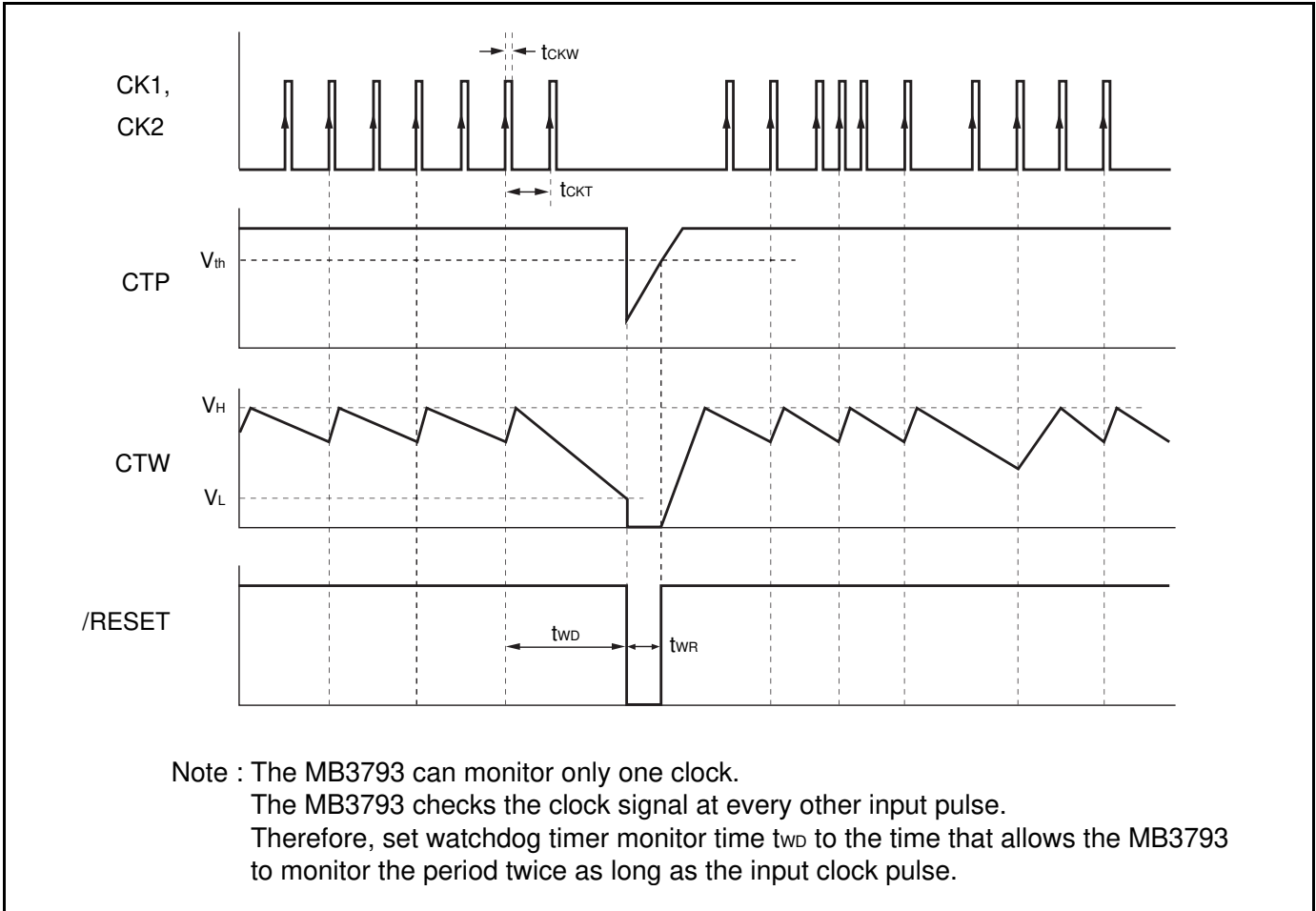

Figure 8-4 Inhibit Function Operation (Positive Clock Pulse)

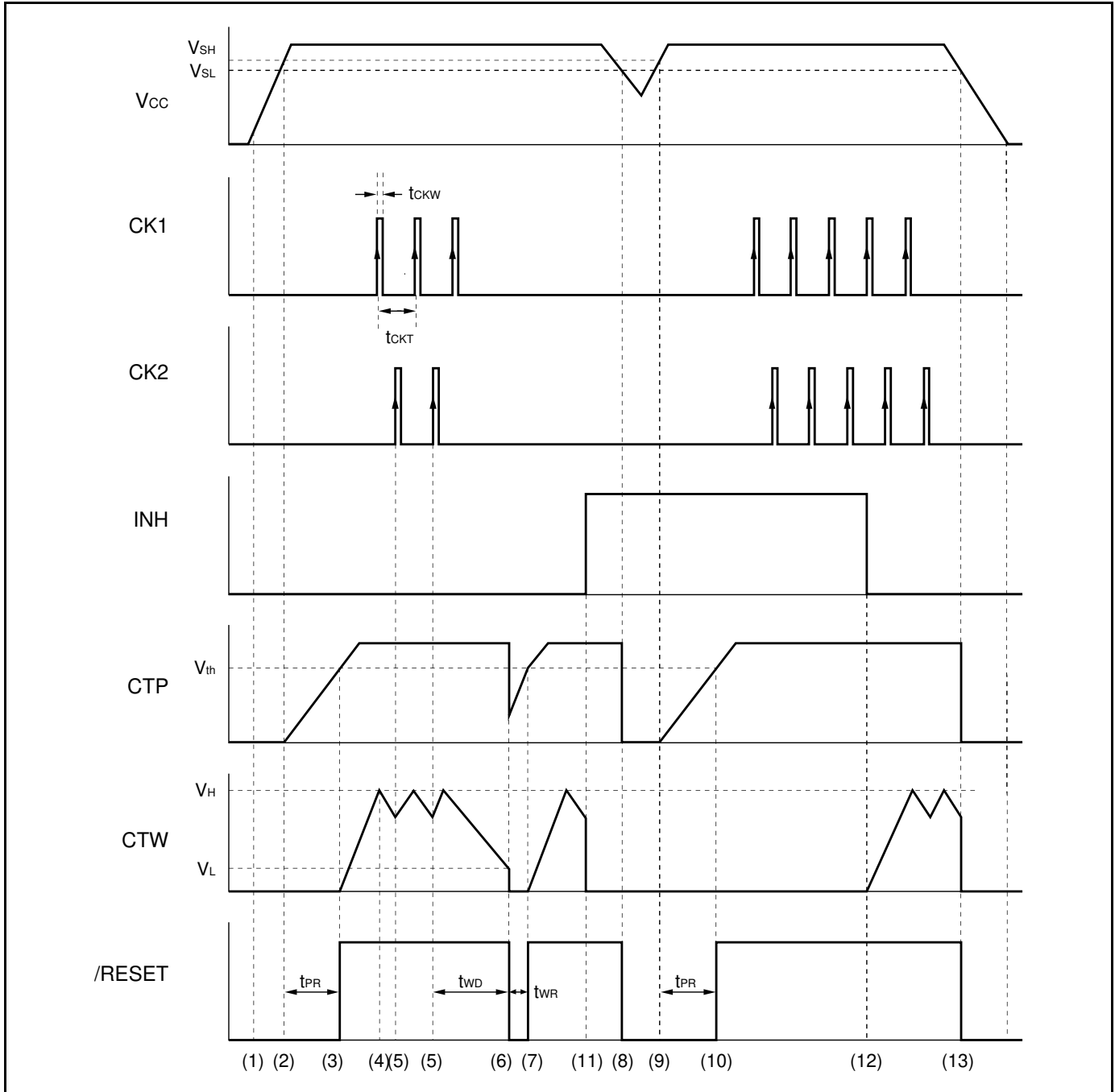
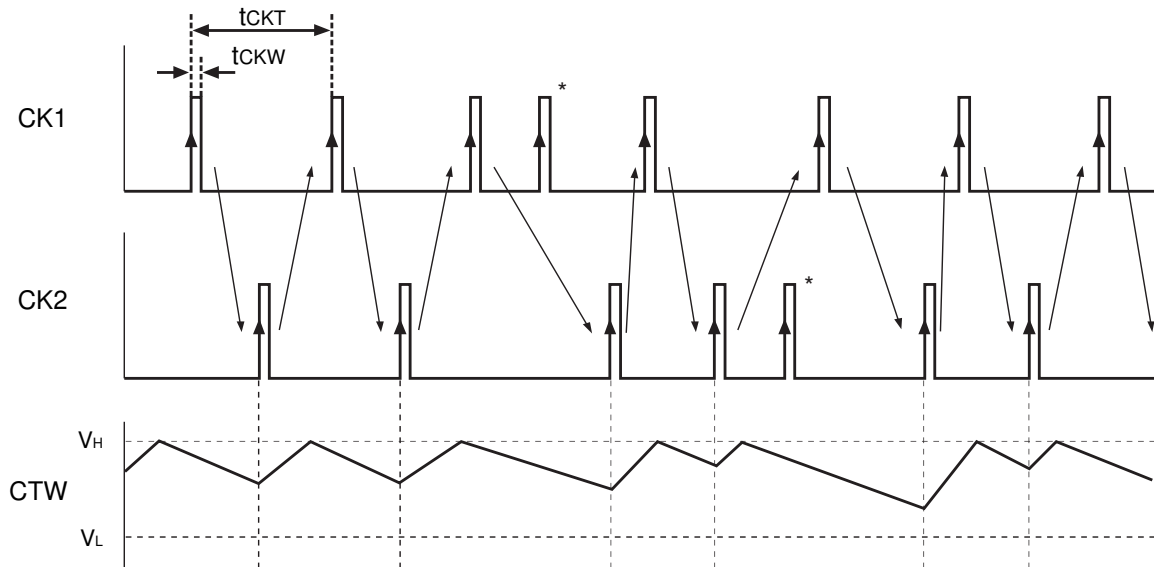

Figure 8-5 Clock Pulse Input Supplementation (Positive Clock Pulse)



Note : The MB3793 watchdog timer monitors Clock1 (CK1) and Clock2 (CK2) pulses alternately. When a CK2 pulse is detected after detecting a CK1 pulse, the monitoring time setting capacity (C_{TW}) switches to charging from discharging. Therefore, the second and later pulses will be ignored even if only CK1 or CK2 pulses are input continuously like * (the * pulse is ignored in the example above).

9. Operation Sequence

Positive Clock Pulse Input

See “Figure 8-1 Basic Operation (Positive Clock Pulse)” under “8. Timing Diagram”.

Negative Clock Pulse Input

See “Figure 8-2 Basic Operation (Negative Clock Pulse)” under “8. Timing Diagram”.

The MB3793 operates in the same way whether it inputs positive or negative pulses.

Single-clock Input Monitoring

To use the MB3793 while monitoring only one clock, connect clock pins CK1 and CK2.

Although the MB3793 operates basically in the same way as when monitoring two clocks, it monitors the clock signal at every other input pulse.

See “Figure 8-3 Single-clock Input Monitoring (Positive Clock Pulse)” under “8. Timing Diagram”.

Description of Operations

The numbers given to the following items correspond to numbers (1) to (13) used in “8. Timing Diagram”.

(1) The MB3793 outputs a reset signal when the power supply voltage (V_{CC}) reaches about 0.8 V (V_{CCL}).

(2) If V_{CC} reaches or exceeds the rise-time detected voltage V_{SH} , the MB3793 starts charging the power-on reset hold time setting capacitor C_{TP} . At this time, the output remains in a reset state.

(3) When C_{TP} has been charged for a certain period of time T_{PR} (until the CTP pin voltage exceeds the threshold voltage (V_{th}) after the start of charging), the MB3793 cancels the reset (setting the /RESET pin to “H” level from “L” level).
The V_{th} value is about 2.4 V with $V_{CC} = 3.3$ V

The power-on reset hold time t_{PR} is set with the following equation:

$$t_{PR} \text{ (ms)} \approx A \times C_{TP} \text{ (}\mu\text{F)}$$

The value of A is about 750 with $V_{CC} = 3.3$ V. The MB3793 also starts charging the watchdog timer monitor time setting capacitor (C_{TW}).

(4) When the voltage at the watchdog timer monitor time setting pin CTW reaches the “H” level threshold voltage V_H , the C_{TW} switches from the charge state to the discharge state.

The value of V_H is always about 1.24 V regardless of the detected voltage.

(5) If the CK2 pin inputs a clock pulse (positive edge trigger) when the C_{TW} is being discharged in the CK1-CK2 order or simultaneously, the C_{TW} switches from the discharge state to the charge state.

The MB3793 repeats operations (4) and (5) as long as the CK1/CK2 pin inputs clock pulses with the system logic circuit operating normally.

(6) If no clock pulse is fed to the CK1 or CK2 pin within the watchdog timer monitor time t_{WD} due to some problem with the system logic circuit, the CTW pin is set to the “L” level threshold voltage V_L or less and the MB3793 outputs a reset signal (setting the /RESET pin to “L” level from “H” level).

The value of V_L is always about 0.24 V regardless of the detected voltage.

The watchdog timer monitor time t_{WD} is set with the following equation:

$$t_{WD} \text{ (ms)} \approx B \times C_{TW} \text{ (}\mu\text{F)} + C \times C_{TP} \text{ (}\mu\text{F)}$$

The value of B is hardly affected by the power supply voltage; it is about 1600 with $V_{CC} = 5.0$ V.

The value of C is 0.

For this reason:

$$t_{WD} \text{ (ms)} \approx B \times C_{TW} \text{ (}\mu\text{F)}$$

(7) When a certain period of time t_{WR} has passed (until the CTP pin voltage reaches or exceeds V_{th} again after recharging the C_{TP}), the MB3793 cancels the reset signal and starts operating the watchdog timer.

The watchdog timer monitor reset time t_{WR} is set with the following equation:

$$t_{WR} \text{ (ms)} \approx D \times C_{TP} \text{ (}\mu\text{F)}$$

The value of D is 55 with $V_{CC} = 3.3 \text{ V}$ and 50 with $V_{CC} = 3.0 \text{ V}$.

The MB3793 repeats operations (4) and (5) as long as the CK1/CK2 pin inputs clock pulses. If no clock pulse is input, the MB3793 repeats operations (6) and (7).

(8) If V_{CC} is lowered to the fall-time detected voltage (V_{SL}) or less, the CTP pin voltage decreases and the MB3793 outputs a reset signal (setting the /RESET pin to "L" level from "H" level).

(9) When V_{CC} reaches or exceeds V_{SH} again, the MB3793 starts charging the C_{TP} .

(10) When the CTP pin voltage reaches or exceeds V_{th} , the MB3793 cancels the reset and restarts operating the watchdog timer. It repeats operations (4) and (5) as long as the CK1/CK2 pin inputs clock pulses.

(11) Making the Inhibit function active (setting the INH pin to "H" from "L") forces the watchdog timer to stop operation.

This stops only the watchdog timer, leaving the MB3793 monitoring V_{CC} (operations (8) to (10)).

The watchdog timer remains inactive unless the Inhibit function pin input is canceled.

The inhibit function (INH) pin must be connecting a voltage of lower as possible impedance, to evade noise.

Set the input pulse time width for Inhibit function (time of "L" level or "H" level) longer than the watchdog timer monitoring time (t_{WD}).

(12) Canceling the inhibit input (setting the INH pin to "L" from "H") restarts the watchdog timer.

(13) The reset signal is output when the power supply is turned off to set V_{CC} to V_{SL} or less.

1. Equation of time-setting capacitances (C_{TP} and C_{TW}) and set time

$$t_{PR} \text{ [ms]} \approx A \times C_{TP} \text{ [}\mu\text{F]}$$

$$t_{WD} \text{ [ms]} \approx B \times C_{TW} \text{ [}\mu\text{F]}$$

$$t_{WR} \text{ [ms]} \approx D \times C_{TP} \text{ [}\mu\text{F]}$$

Values of A, B, C and D

A	B	C	D	Remark
750	1600	0	55	$V_{CC} = 3.3 \text{ V}$
1300	1500	0	100	$V_{CC} = 5.0 \text{ V}$

Note: The width of value of t_{PR} , t_{WD} and t_{WR} becomes the same ratio as width (Min, Max) of each specification value.

2. Example (when $C_{TP} = 0.1 \mu\text{F}$ and $C_{TW} = 0.01 \mu\text{F}$)

	Symbol	$V_{CC} = 3.3 \text{ V}$	$V_{CC} = 5.0 \text{ V}$
time (ms)	t_{PR}	75	130
	t_{WD}	16	15
	t_{WR}	5.5	10

10. Typical Characteristics

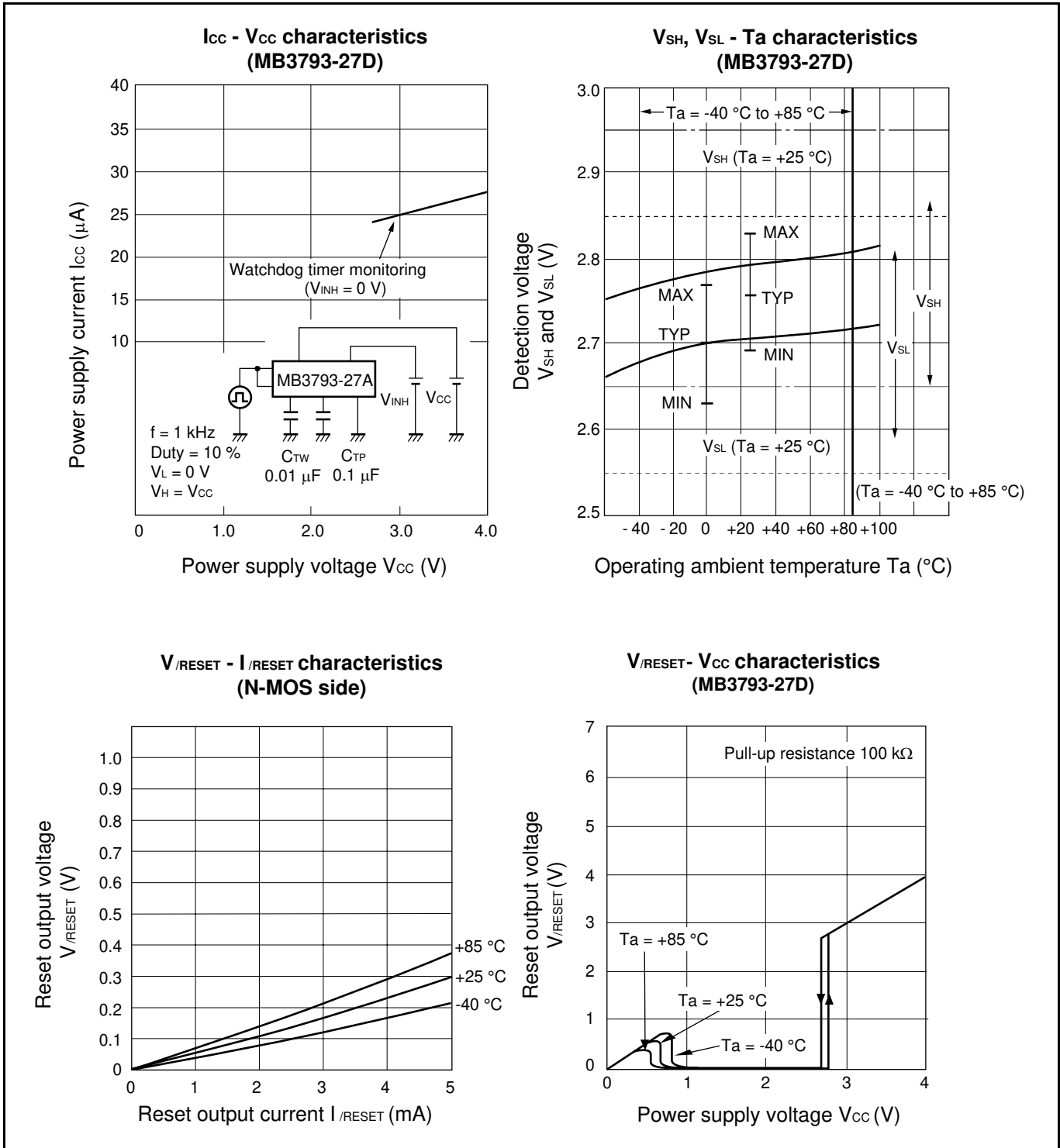

**$V_{\text{RESET}} - V_{\text{CC}}$ characteristics
(MB3793-27D)**

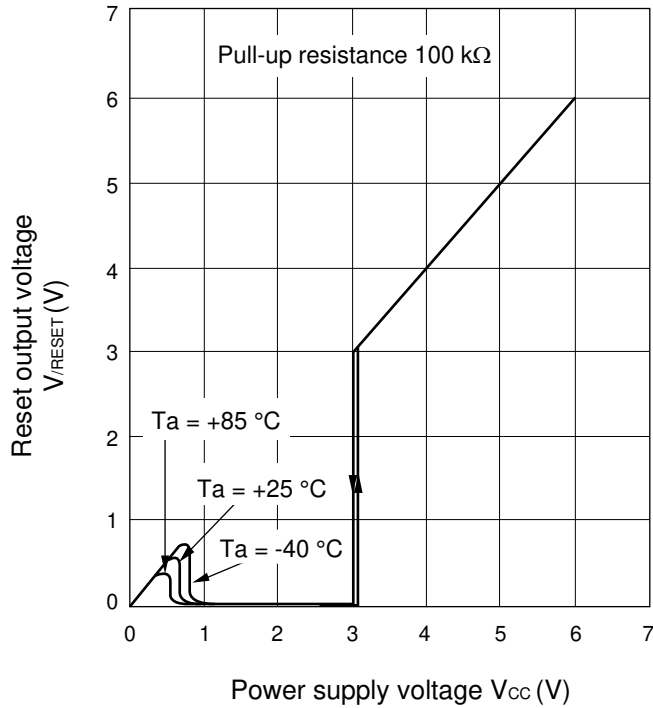

$t_{\text{PR}} - T_a$ characteristics

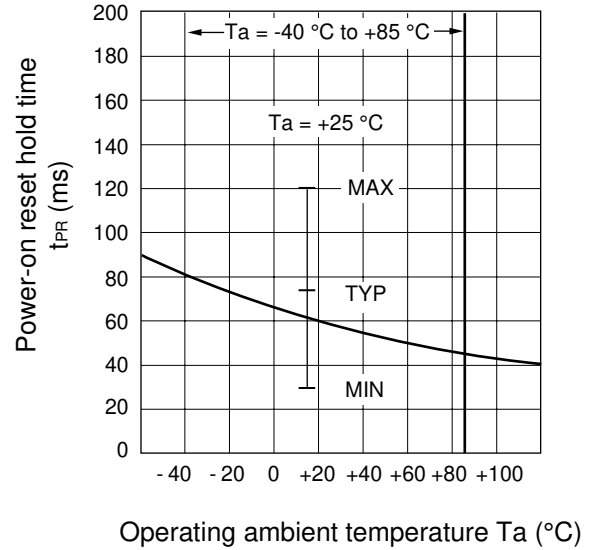

$t_{\text{WR}} - T_a$ characteristics

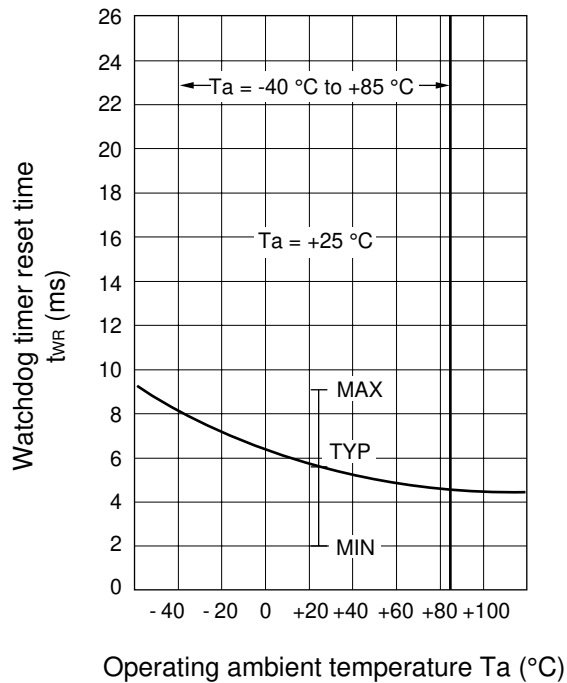

$t_{\text{WD}} - T_a$ characteristics

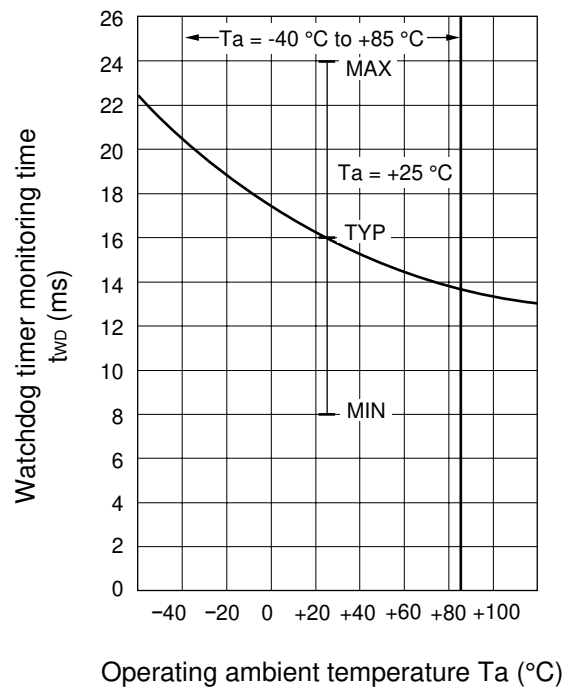

$t_{PR} - C_{TP}$ characteristics

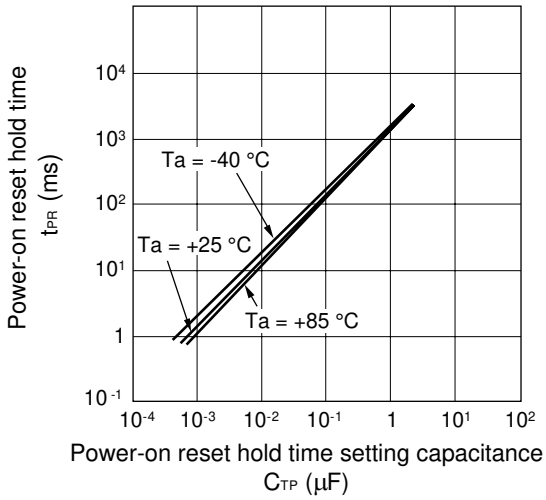

$t_{WR} - C_{TP}$ characteristics

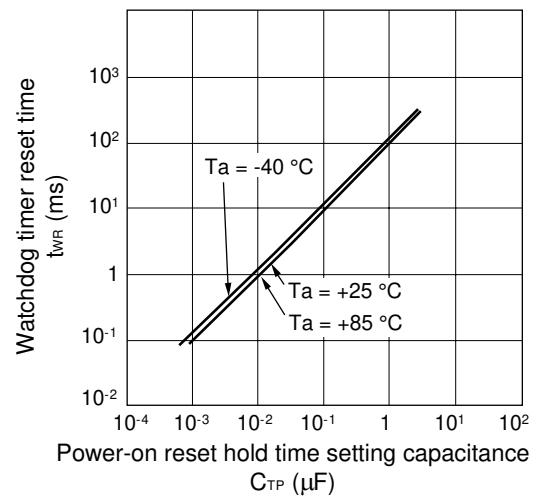

$t_{WD} - C_{TW}$ characteristics

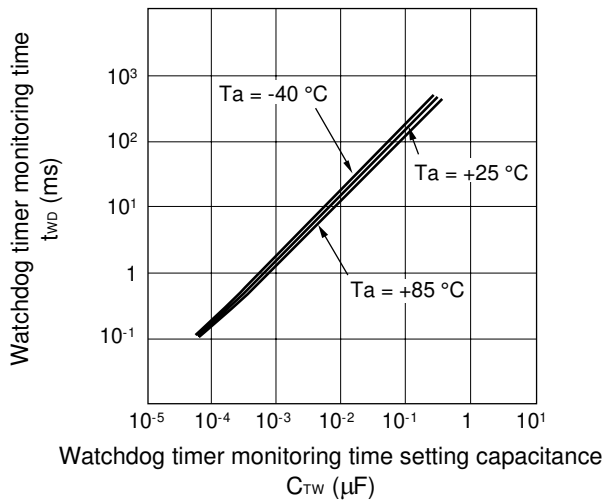

11. Application Example

Power Supply Voltage Monitor and Watchdog Timer

1. 1-clock monitor

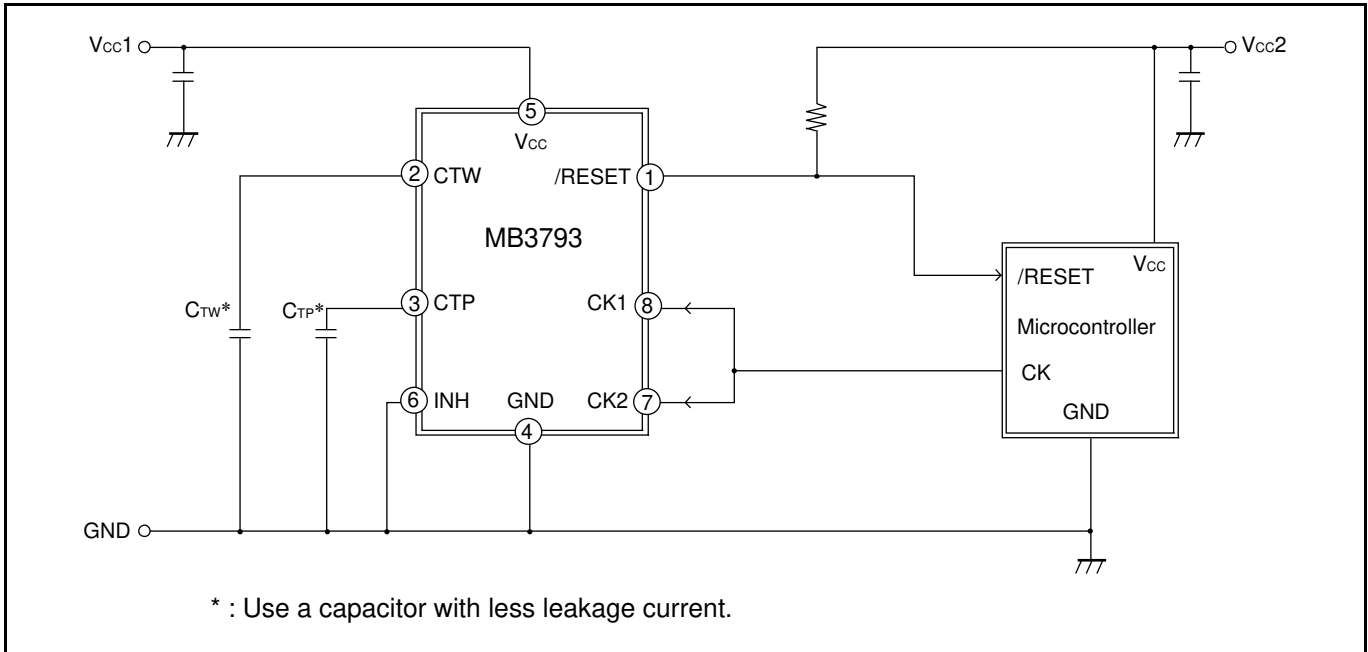

2. 2-clock monitor

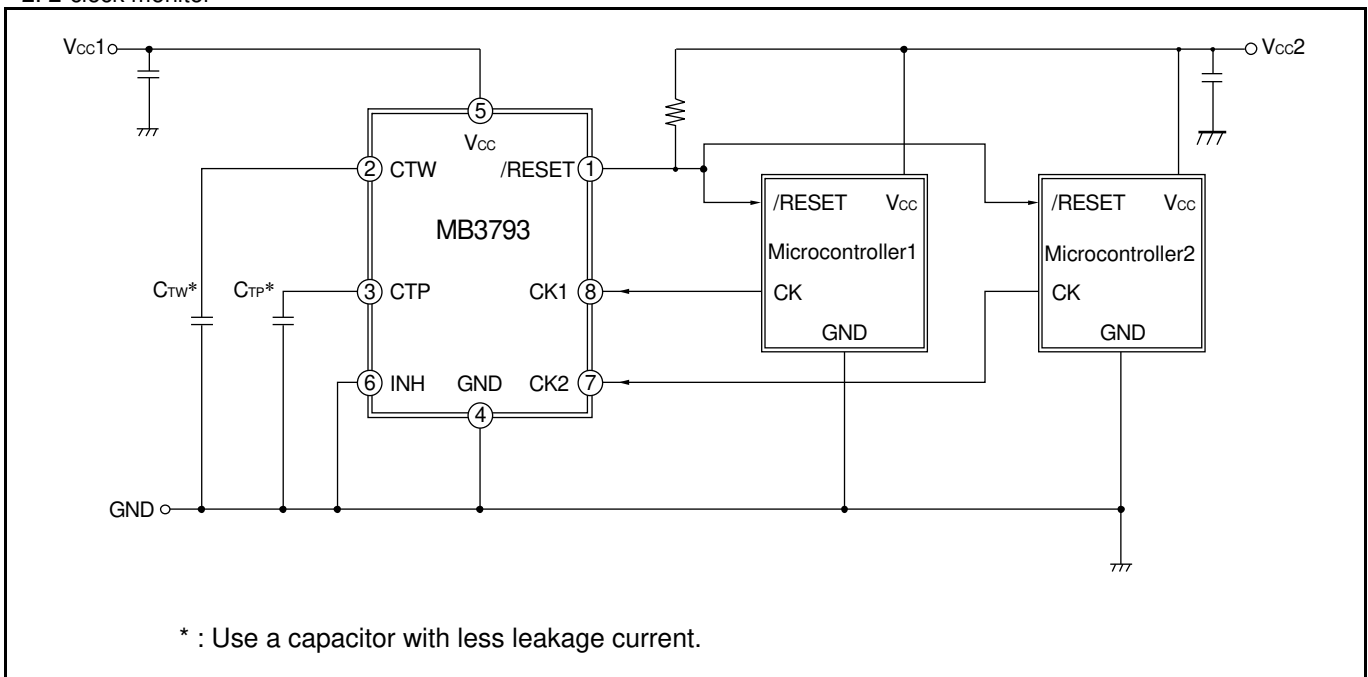

Power Supply Voltage Monitor and Watchdog Timer Stop

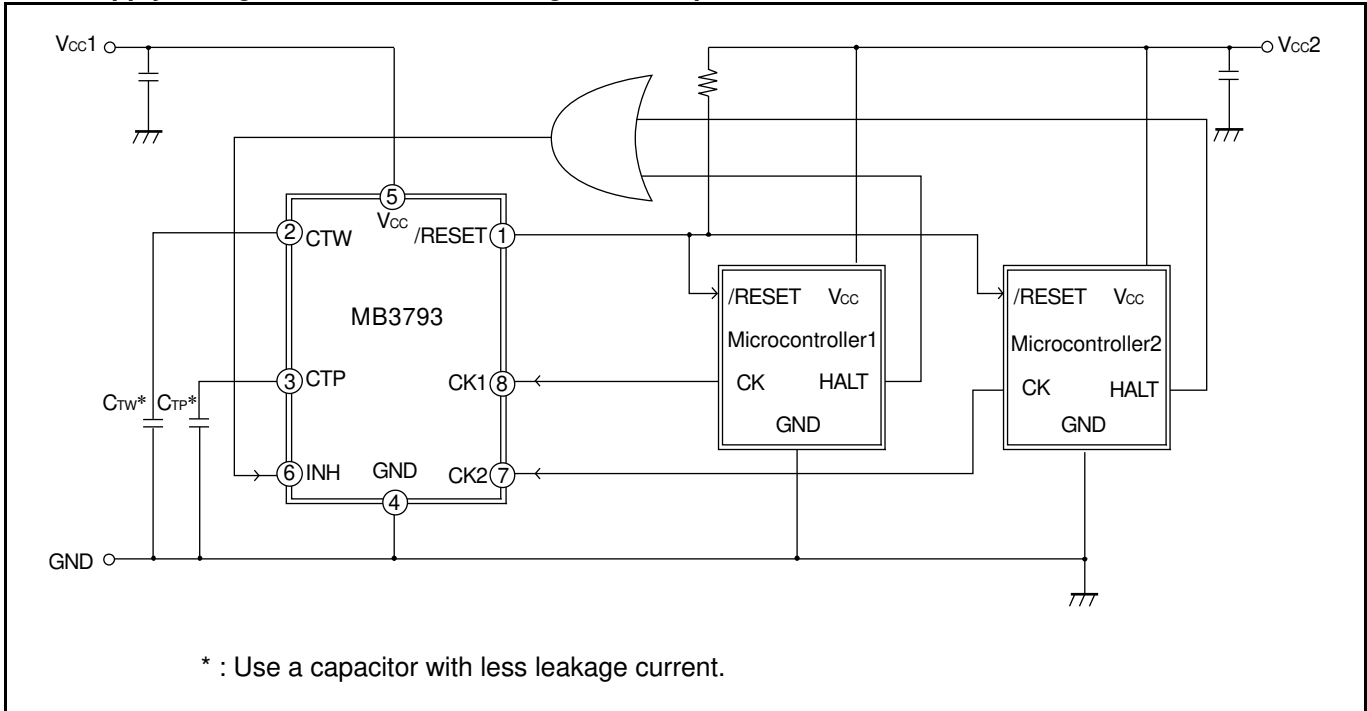

Setting of Compulsory Reset

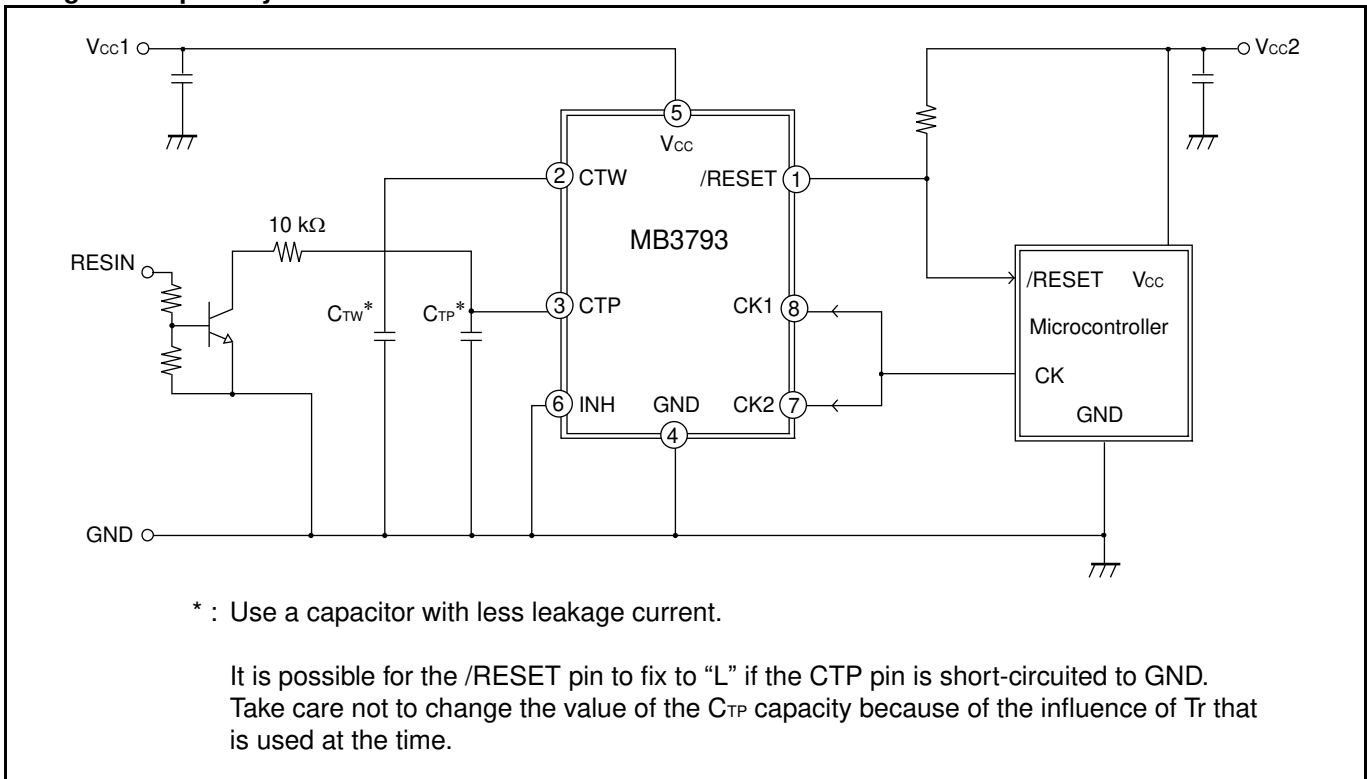

12. Usage Precaution

Do not Configure the IC Over the Maximum Ratings

If the IC is used over the maximum ratings, the LSI may be permanently damaged. It is preferable for the device to normally operate within the recommended usage conditions. Usage outside of these conditions can have a bad effect on the reliability of the LSI.

Use the Devices within Recommended Operating Conditions

The recommended operating conditions are the recommended values that guarantee the normal operations of LSI. The electrical ratings are guaranteed when the device is used within the recommended operating conditions and under the conditions stated for each item.

Printed Circuit Board Ground Lines Should be Set up with Consideration for Common Impedance

Take Appropriate Measures Against Static Electricity

- Containers for semiconductor materials should have anti-static protection or be made of conductive material.
- After mounting, printed circuit boards should be stored and shipped in conductive bags or containers.
- Work platforms, tools, and instruments should be properly grounded.
- Working personnel should be grounded with resistance of 250 kΩ to 1 MΩ in series between body and ground.

Do not Apply Negative Voltages

The use of negative voltages below -0.3 V may create parasitic transistors on LSI lines, which can cause malfunctions.

13. Ordering Information

Part Number	Package
MB3793-27DPNF	8-pin plastic SOP (SOB008)
MB3793-28DPNF	8-pin plastic SOP (SOB008)
MB3793-30DPNF	8-pin plastic SOP (SOB008)

14. RoHS Compliance Information

The LSI products of Cypress with "E1" are compliant with RoHS Directive, and have observed the standard of lead, cadmium, mercury, Hexavalent chromium, polybrominated biphenyls (PBB), and polybrominated diphenyl ethers (PBDE).

The product that conforms to this standard is added "E1" at the end of the part number.

15. Package Dimensions

Package Code: SOB008

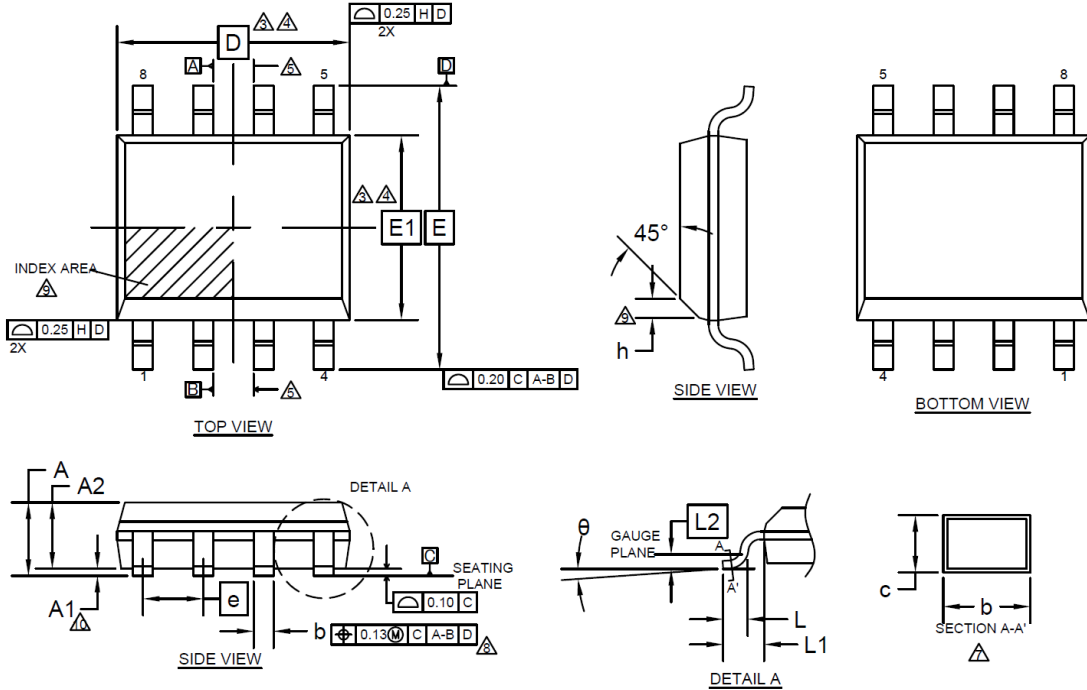

SYMBOL	DIMENSIONS		
	MIN.	NOM.	MAX.
A	—	—	1.75
A1	0.05	—	0.25
A2	1.30	1.40	1.50
D	5.05 BSC.		
E	6.00 BSC.		
E1	3.90 BSC		
θ	0°	—	8°
c	0.15	—	0.25
b	0.36	0.44	0.52
L	0.45	0.60	0.75
L 1	1.05 REF		
L 2	0.25 BSC		
e	1.27 BSC.		
h	0.40 BSC.		

NOTES

1. ALL DIMENSIONS ARE IN MILLIMETER.
2. DIMENSIONING AND TOLERANCING PER ASME Y14.5M-1994.
3. DIMENSIONING D INCLUDE MOLD FLASH, DIMENSIONING E1 DOES NOT INCLUDE INTERLEAD FLASH OR PROTRUSION. INTERLEAD FLASH OR PROTRUSIONS SHALL NOT EXCEED 0.025 mm PER SIDE. D and E1 DIMENSION ARE DETERMINED AT DATUM H.
4. THE PACKAGE TOP MAY BE SMALLER THAN THE PACKAGE BOTTOM. DIMENSIONING D and E1 ARE DETERMINED AT THE OUTERMOST EXTREMES OF THE PLASTIC BODY EXCLUSIVE OF MOLD FLASH, THE BAR BURRS, GATE BURRS AND INTERLEAD FLASH, BUT INCLUDING ANY MISMATCH BETWEEN THE TOP AND BOTTOM OF THE PLASTIC BODY.
5. DATUMS A & B TO BE DETERMINED AT DATUM H.
6. "N" IS THE MAXIMUM NUMBER OF TERMINAL POSITIONS FOR THE SPECIFIED PACKAGE LENGTH.
7. THE DIMENSION APPLY TO THE FLAT SECTION OF THE LEAD BETWEEN 0.10 mm TO 0.25mm FROM THE LEAD TIP.
8. DIMENSION "b" DOES NOT INCLUDE THE DAMBAR PROTRUSION. ALLOWABLE DAMBAR PROTRUSION SHALL BE 0.10mm TOTAL IN EXCESS OF THE "b" DIMENSION AT MAXIMUM MATERIAL CONDITION. THE DAMBAR MAY NOT BE LOCATED ON THE LOWER RADIUS OF THE FOOT.
9. THIS CHAMFER FEATURE IS OPTIONAL. IF IT IS NOT PRESENT, THEN A PIN 1 IDENTIFIER MUST BE LOCATED WITHIN THE INDEX AREA INDICATED
10. "A1" IS DEFINED AS THE VERTICAL DISTANCE FROM THE SEATING PLANE TO THE LOWEST POINT ON THE PACKAGE BODY EXCLUDING THE LID AND OR THERMAL ENHANCEMENT ON CAVITY DOWN PACKAGE CONFIGURATIONS.
11. JEDEC SPECIFICATION NO. REF : N/A

002-15856 Rev. **

16. Major Changes

Spansion Publication Number: DS405-00023

Page	Section	Change Results
Revision 1.0 (11/28/2014)		
-	-	Initial release

NOTE: Please see “Document History” about later revised information.

Document History

Document Title: MB3793-27D/28D/30D Power-Voltage Monitoring IC with Watchdog Timer

Document Number: 002-08488

Revision	ECN	Orig. of Change	Submission Date	Description of Change
**	-	TAOA	11/28/2014	Initial release
*A	5142374	TAOA	02/23/2016	Migrated Spansion Datasheet from DS405-00023-1v0-E to Cypress format
*B	5623711	HIXT	02/09/2017	Updated Pin Description : Change the package name from FPT-8P-M02 to SOB008 Updated description in the 4. Block Functions Output circuit Updated Ordering Information : Change the package name from FPT-8P-M02 to SOB008 Updated Package Dimensions : Updated to Cypress format Deleted “Marking Format” Deleted “Labeling Sample” Deleted “MB3793-27D/28D/30D Recommended Conditions of Moisture Sensitivity”

Sales, Solutions, and Legal Information

Worldwide Sales and Design Support

Cypress maintains a worldwide network of offices, solution centers, manufacturer's representatives, and distributors. To find the office closest to you, visit us at [Cypress Locations](#).

Products

ARM® Cortex® Microcontrollers	cypress.com/arm
Automotive	cypress.com/automotive
Clocks & Buffers	cypress.com/clocks
Interface	cypress.com/interface
Internet of Things	cypress.com/iot
Memory	cypress.com/memory
Microcontrollers	cypress.com/mcu
PSoC	cypress.com/psoc
Power Management ICs	cypress.com/pmic
Touch Sensing	cypress.com/touch
USB Controllers	cypress.com/usb
Wireless/RF	cypress.com/wireless

PSoC® Solutions

[PSoC 1](#) | [PSoC 3](#) | [PSoC 4](#) | [PSoC 5LP](#)

Cypress Developer Community

[Forums](#) | [WICED IOT Forums](#) | [Projects](#) | [Video](#) | [Blogs](#) | [Training](#) | [Components](#)

Technical Support

cypress.com/support

© Cypress Semiconductor Corporation, 2014-2017. This document is the property of Cypress Semiconductor Corporation and its subsidiaries, including Spansion LLC ("Cypress"). This document, including any software or firmware included or referenced in this document ("Software"), is owned by Cypress under the intellectual property laws and treaties of the United States and other countries worldwide. Cypress reserves all rights under such laws and treaties and does not, except as specifically stated in this paragraph, grant any license under its patents, copyrights, trademarks, or other intellectual property rights. If the Software is not accompanied by a license agreement and you do not otherwise have a written agreement with Cypress governing the use of the Software, then Cypress hereby grants you a personal, non-exclusive, nontransferable license (without the right to sublicense) (1) under its copyright rights in the Software (a) for Software provided in source code form, to modify and reproduce the Software solely for use with Cypress hardware products, only internally within your organization, and (b) to distribute the Software in binary code form externally to end users (either directly or indirectly through resellers and distributors), solely for use on Cypress hardware product units, and (2) under those claims of Cypress's patents that are infringed by the Software (as provided by Cypress, unmodified) to make, use, distribute, and import the Software solely for use with Cypress hardware products. Any other use, reproduction, modification, translation, or compilation of the Software is prohibited.

TO THE EXTENT PERMITTED BY APPLICABLE LAW, CYPRESS MAKES NO WARRANTY OF ANY KIND, EXPRESS OR IMPLIED, WITH REGARD TO THIS DOCUMENT OR ANY SOFTWARE OR ACCOMPANYING HARDWARE, INCLUDING, BUT NOT LIMITED TO, THE IMPLIED WARRANTIES OF MERCHANTABILITY AND FITNESS FOR A PARTICULAR PURPOSE. To the extent permitted by applicable law, Cypress reserves the right to make changes to this document without further notice. Cypress does not assume any liability arising out of the application or use of any product or circuit described in this document. Any information provided in this document, including any sample design information or programming code, is provided only for reference purposes. It is the responsibility of the user of this document to properly design, program, and test the functionality and safety of any application made of this information and any resulting product. Cypress products are not designed, intended, or authorized for use as critical components in systems designed or intended for the operation of weapons, weapons systems, nuclear installations, life-support devices or systems, other medical devices or systems (including resuscitation equipment and surgical implants), pollution control or hazardous substances management, or other uses where the failure of the device or system could cause personal injury, death, or property damage ("Unintended Uses"). A critical component is any component of a device or system whose failure to perform can be reasonably expected to cause the failure of the device or system, or to affect its safety or effectiveness. Cypress is not liable, in whole or in part, and you shall and hereby do release Cypress from any claim, damage, or other liability arising from or related to all Unintended Uses of Cypress products. You shall indemnify and hold Cypress harmless from and against all claims, costs, damages, and other liabilities, including claims for personal injury or death, arising from or related to any Unintended Uses of Cypress products.

Cypress, the Cypress logo, Spansion, the Spansion logo, and combinations thereof, WICED, PSoC, CapSense, EZ-USB, F-RAM, and Traveo are trademarks or registered trademarks of Cypress in the United States and other countries. For a more complete list of Cypress trademarks, visit cypress.com. Other names and brands may be claimed as property of their respective owners.