



Chipsmall Limited consists of a professional team with an average of over 10 year of expertise in the distribution of electronic components. Based in Hongkong, we have already established firm and mutual-benefit business relationships with customers from,Europe,America and south Asia,supplying obsolete and hard-to-find components to meet their specific needs.

With the principle of “Quality Parts,Customers Priority,Honest Operation,and Considerate Service”,our business mainly focus on the distribution of electronic components. Line cards we deal with include Microchip,ALPS,ROHM,Xilinx,Pulse,ON,Everlight and Freescale. Main products comprise IC,Modules,Potentiometer,IC Socket,Relay,Connector.Our parts cover such applications as commercial,industrial, and automotives areas.

We are looking forward to setting up business relationship with you and hope to provide you with the best service and solution. Let us make a better world for our industry!



Contact us

Tel: +86-755-8981 8866 Fax: +86-755-8427 6832

Email & Skype: info@chipsmall.com Web: www.chipsmall.com

Address: A1208, Overseas Decoration Building, #122 Zhenhua RD., Futian, Shenzhen, China



The MB39A112 is a 3-channel DC/DC converter IC using pulse width modulation (PWM), and the MB39A112 is suitable for down-conversion.

3-channel is built in TSSOP-20P package. Each channel can be controlled and soft-start.

The MB39A112 contains a constant voltage bias circuit for output block, capable of implementing an efficient high-frequency DC/DC converter. It is ideal for built-in power supply such as ADSL modems.

Features

- Supports for down-conversion (CH1 to CH3)
- Power supply voltage range : 7 V to 25 V
- Error amplifier threshold voltage : 1.00 V \pm 1% (CH1)
: 1.23 V \pm 1% (CH2, CH3)
- Oscillation frequency range : 250 kHz to 2.6 MHz
- Built-in soft-start circuit independent of loads
- Built-in timer-latch short-circuit protection circuit
- Built-in totem-pole type output for P-channel MOS FET devices
- Built-in constant voltage (VCCO - 5 V) bias circuit for output block

Package

20-pin plastic TSSOP

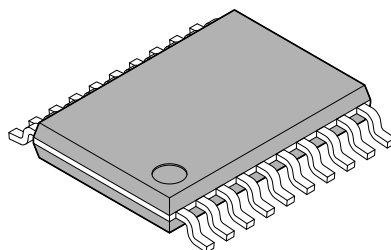

(FPT-20P-M06)

Contents

Pin Assignment	3	Setting Time Constant For Timer-latch	
Pin Description	4	Short-circuit Protection Circuit	17
Block Diagram	5	Treatment Without Using CSCP Terminal	18
Absolute Maximum Ratings	6	I/O Equivalent Circuit	19
Recommended Operating Conditions	6	Application Example	20
Electrical Characteristics	7	Parts List	21
Typical Characteristics	9	Selection Of Components	22
Function	12	Reference Data	32
DC/DC Converter Function	12	Usage Precaution	35
Protective Function	12	Ordering Information	35
Setting The Output Voltage	14	Package Dimension	36
Setting The Triangular Oscillation Frequency	14	Document History	37
Setting The Soft-start And Discharge Times	15	Sales, Solutions, and Legal Information	38
Treatment Without Using CS Terminal	16		

1. Pin Assignment

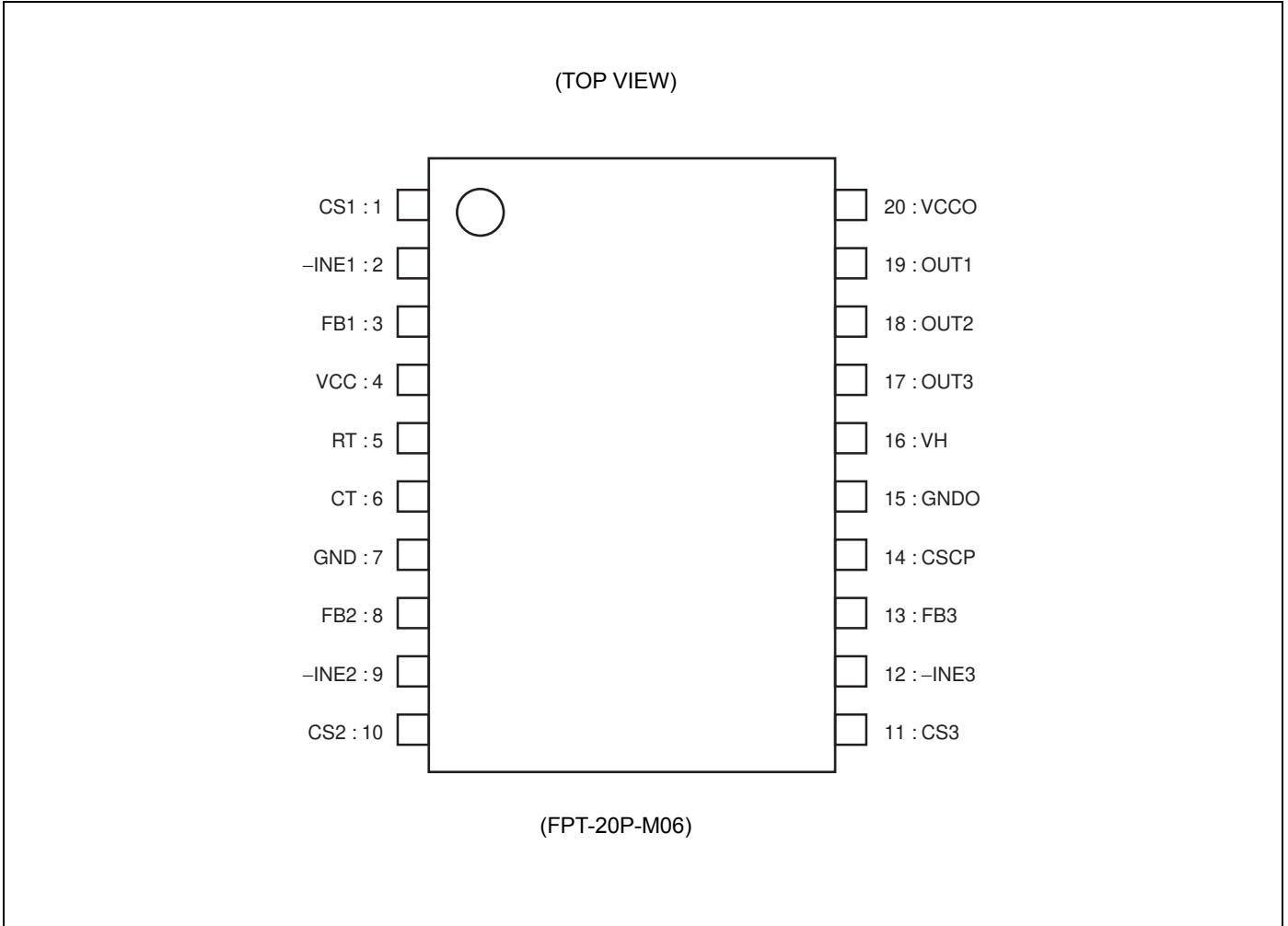

2. Pin Description

Pin No.	Symbol	I/O	Descriptions
1	CS1	—	CH1 soft-start setting capacitor connection terminal.
2	- INE1	I	CH1 error amplifier inverted input terminal.
3	FB1	O	CH1 error amplifier output terminal.
4	VCC	—	Control circuit power supply terminal.
5	RT	—	Triangular-wave oscillation frequency setting resistor connection terminal.
6	CT	—	Triangular-wave oscillation frequency setting capacitor connection terminal.
7	GND	—	Ground terminal.
8	FB2	O	CH2 error amplifier output terminal.
9	- INE2	I	CH2 error amplifier inverted input terminal.
10	CS2	—	CH2 soft-start setting capacitor connection terminal.
11	CS3	—	CH3 soft-start setting capacitor connection terminal.
12	- INE3	I	CH3 error amplifier inverted input terminal.
13	FB3	O	CH3 error amplifier output terminal.
14	CSCP	—	Timer-latch short-circuit protection capacitor connection terminal.
15	GNDO	—	Ground terminal.
16	VH	O	Power supply terminal for driving output circuit. (VH = VCCO - 5 V) .
17	OUT3	O	CH3 external Pch MOS FET gate driving terminal.
18	OUT2	O	CH2 external Pch MOS FET gate driving terminal.
19	OUT1	O	CH1 external Pch MOS FET gate driving terminal.
20	VCCO	—	Power supply terminal for driving output circuit. (Connect to same potential as VCC terminal).

3. Block Diagram

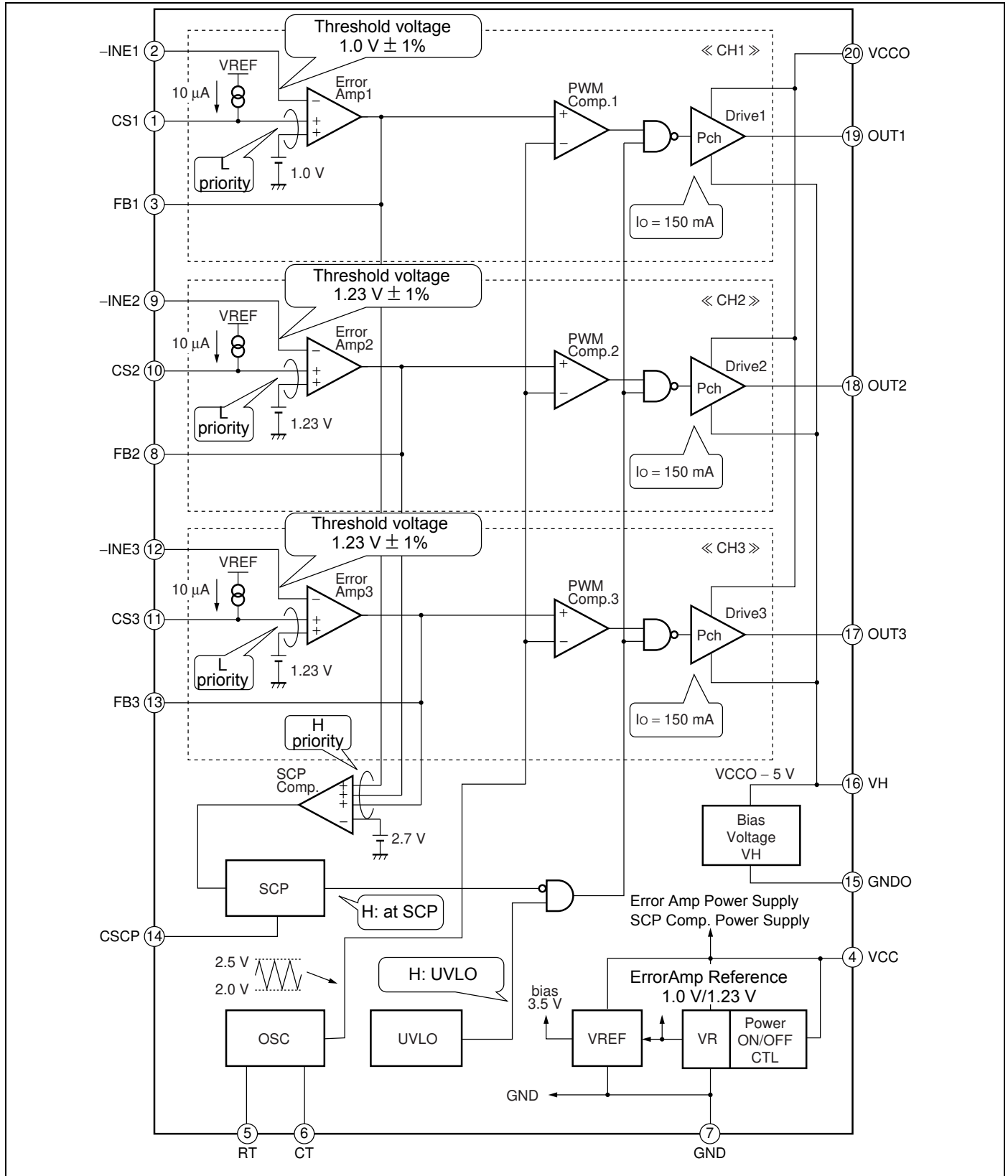

4. Absolute Maximum Ratings

Parameter	Symbol	Conditions	Rating		Unit
			Min	Max	
Power supply voltage	V _{CC}	VCC, VCCO terminal	—	28	V
Output current	I _O	OUT1, OUT2, OUT3 terminal	—	20	mA
Peak output current	I _{OP}	Duty ≤ 5 % (t = 1/fosc × Duty)	—	400	mA
Power dissipation	P _D	T _a ≤ + 25 °C	—	1280*	mW
Storage temperature	T _{STG}	—	- 55	+ 125	°C

* : The package is mounted on the dual-sided epoxy board (10 cm × 10 cm) .

WARNING: Semiconductor devices can be permanently damaged by application of stress (voltage, current, temperature, etc.) in excess of absolute maximum ratings. Do not exceed these ratings.

5. Recommended Operating Conditions

Parameter	Symbol	Conditions	Value			Unit
			Min	Typ	Max	
Power supply voltage	V _{CC}	VCC, VCCO terminal	7	12	25	V
Input voltage	V _{IN}	- INE terminal	0	—	V _{CC} - 1.8	V
Output current	I _O	OUT1, OUT2, OUT3 terminal	- 15	—	15	mA
	I _{VH}	VH terminal	0	—	30	mA
Oscillation frequency	fosc	—	250	1200	2600	kHz
Timing capacitor	C _T	—	22	100	1000	pF
Timing resistor	R _T	—	4.7	10	22	kΩ
VH terminal capacitor	C _{VH}	VH terminal	—	0.1	1.0	μF
Soft-start capacitor	C _S	CS1, CS2, CS3 terminal	—	0.1	1.0	μF
Short-circuit detection capacitor	C _{SCP}	CSCP terminal	—	0.01	1.0	μF
Operating ambient temperature	T _a	—	- 30	+ 25	+ 85	°C

WARNING: The recommended operating conditions are required in order to ensure the normal operation of the semiconductor device. All of the device's electrical characteristics are warranted when the device is operated within these ranges. Always use semiconductor devices within their recommended operating condition ranges. Operation outside these ranges may adversely affect reliability and could result in device failure. No warranty is made with respect to uses, operating conditions, or combinations not represented on the data sheet. Users considering application outside the listed conditions are advised to contact their Cypress representatives beforehand.

6. Electrical Characteristics

(VCC = VCCO = 12 V, Ta = + 25 °C)

Parameter		Symbol	Pin No.	Conditions	Value			Unit
					Min	Typ	Max	
Undervoltage Lockout Protection Circuit Block [UVLO]	Threshold voltage	V _{TH}	4	VCC = \bar{V}	6.35	6.55	6.75	V
	Hysteresis width	V _{HYS}	4	—	—	0.15	—	V
Short-circuit Protection Circuit Block [SCP]	Threshold voltage	V _{TH}	14	—	0.67	0.72	0.77	V
	Input source current	I _{CSCP}	14	—	- 1.4	- 1.0	- 0.6	μA
	Reset voltage	V _{RST}	4	VCC = \bar{V}	6.2	6.4	6.6	V
Triangular Wave Oscillator Block [OSC]	Oscillation frequency	f _{osc}	17 to 19	CT = 100 pF, RT = 10 kΩ	1080	1200	1320	kHz
Soft-start Block [CS1, CS2, CS3]	Charge current	I _{CS}	1, 10, 11	—	- 14	- 10	- 6	μA
Error Amp Block (CH1) [Error Amp1]	Threshold voltage	V _{TH}	2	FB1 = 2.25 V	0.99	1.00	1.01	V
	Input bias current	I _B	2	- INE1 = 0 V	- 250	- 63	—	nA
	Voltage gain	A _V	3	DC	60	100	—	dB
	Frequency band width	B _W	3	A _V = 0dB	—	1.5*	—	MHz
	Output voltage	V _{OH}	3	—	3.2	3.4	—	V
		V _{OL}	3	—	—	40	200	mV
	Output source current	I _{SOURCE}	3	FB1 = 2.25 V	—	- 2	- 1	mA
Output sink current	I _{SINK}	3	FB1 = 2.25 V	150	250	—	μA	
Error Amp Block (CH2, CH3) [Error Amp2, Error Amp3]	Threshold voltage	V _{TH}	9, 12	FB2 = FB3 = 2.25 V	1.218	1.230	1.242	V
	Input bias current	I _B	9, 12	- INE2 = - INE3 = 0 V	- 250	- 63	—	nA
	Voltage gain	A _V	8, 13	DC	60	100	—	dB
	Frequency band width	B _W	8, 13	A _V = 0 dB	—	1.5*	—	MHz
	Output voltage	V _{OH}	8, 13	—	3.2	3.4	—	V
		V _{OL}	8, 13	—	—	40	200	mV
	Output source current	I _{SOURCE}	8, 13	FB2 = FB3 = 2.25 V	—	- 2	- 1	mA
	Output sink current	I _{SINK}	8, 13	FB2 = FB3 = 2.25 V	150	250	—	μA

*: Standard design value

(Continued)

(Continued)

(VCC = VCCO = 12 V, Ta = + 25 °C)

Parameter		Symbol	Pin No.	Conditions	Value			Unit
					Min	Typ	Max	
PWM Comparator Block [PWM Comp.]	Threshold voltage	V _{TO}	17 to 19	Duty cycle = 0 %	1.9	2.0	—	V
		V _{T100}	17 to 19	Duty cycle = 100 %	—	2.5	2.6	V
Bias Voltage Block [VH]	Output voltage	V _H	16	—	V _{CCO} - 5.5	V _{CCO} - 5.0	V _{CCO} - 4.5	V
Output Block [Drive]	Output source current	I _{SOURCE}	17 to 19	Duty ≤ 5 % OUT1 = OUT2 = OUT3 = 7 V	—	- 150*	—	mA
	Output sink current	I _{SINK}	17 to 19	Duty ≤ 5 % OUT1 = OUT2 = OUT3 = 12 V	—	150*	—	mA
	Output ON resistor	R _{OH}	17 to 19	OUT1 = OUT2 = OUT3 = - 15 mA	—	13	19.5	Ω
		R _{OL}	17 to 19	OUT1 = OUT2 = OUT3 = 15 mA	—	10	15	Ω
General	Power supply current	I _{CC}	4	—	—	6	9	mA

*: Standard design value

7. Typical Characteristics

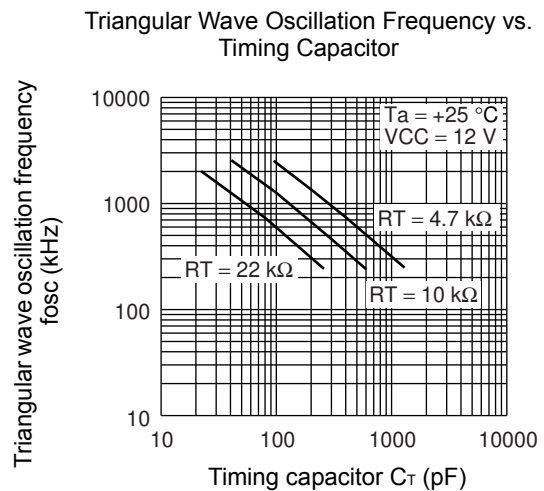
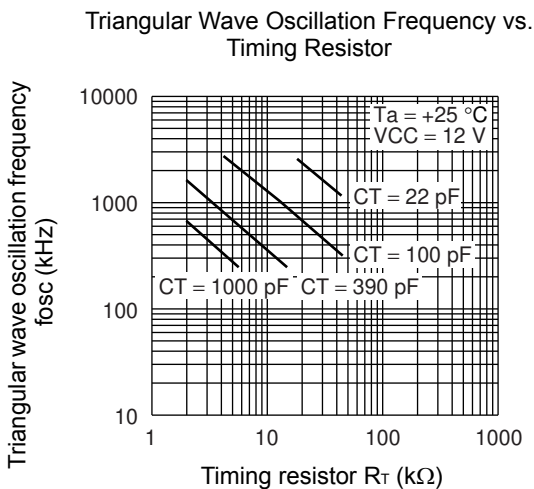
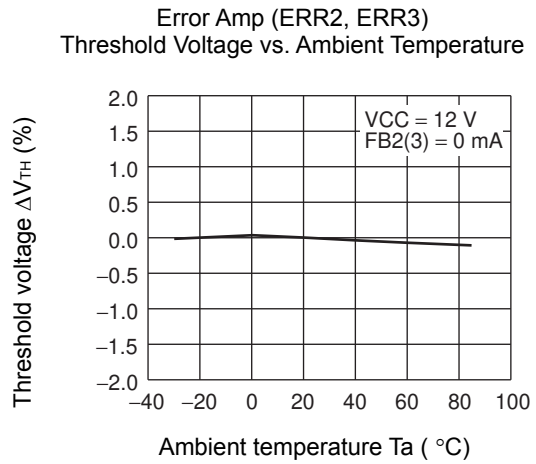
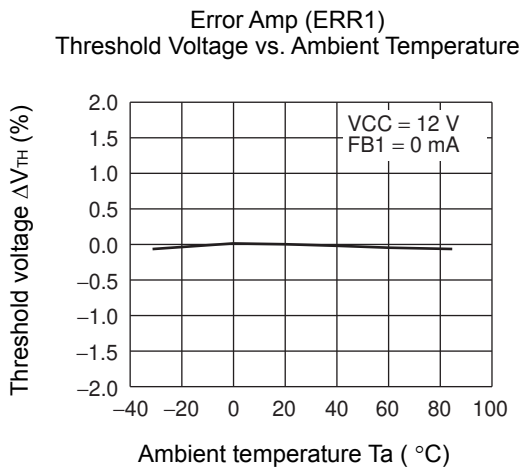
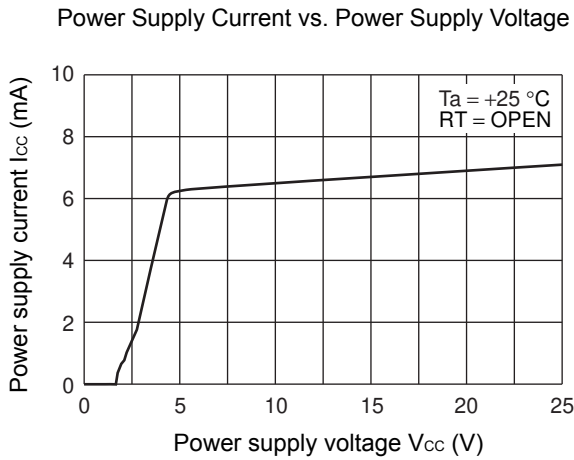

(Continued)

Triangular Wave Upper/Lower Limit Voltage vs. Triangular Wave Oscillation Frequency

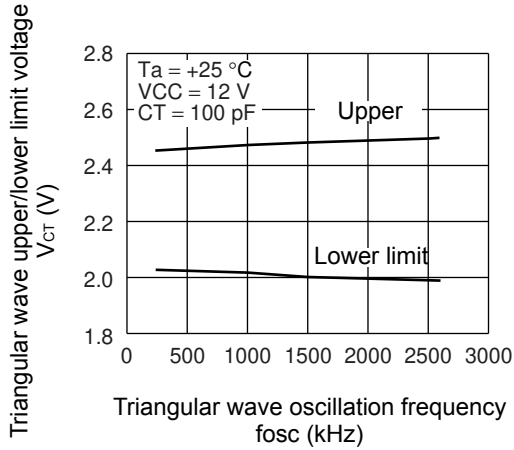

Triangular Wave Upper/Lower Limit Voltage vs. Ambient Temperature

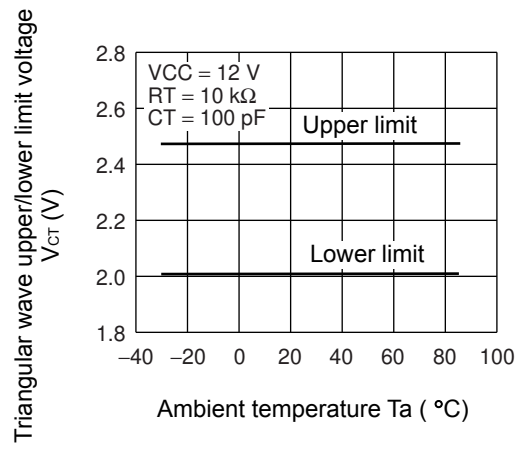

Triangular Wave Oscillation Frequency vs. Ambient Temperature

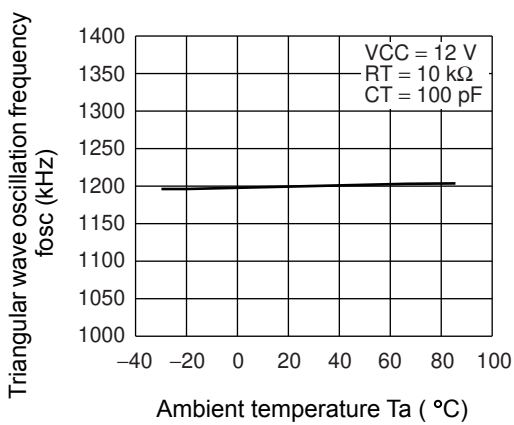

Triangular Wave Oscillation Frequency vs. Power Supply Voltage

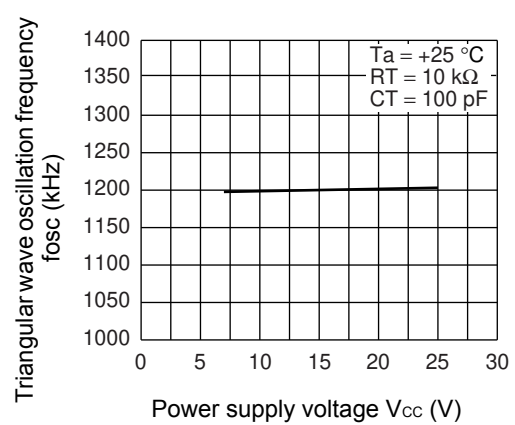

(Continued)

(Continued)

Error Amp (CH1)
Gain, Phase vs. Frequency

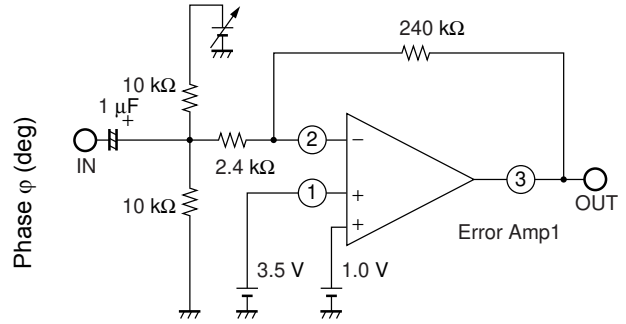
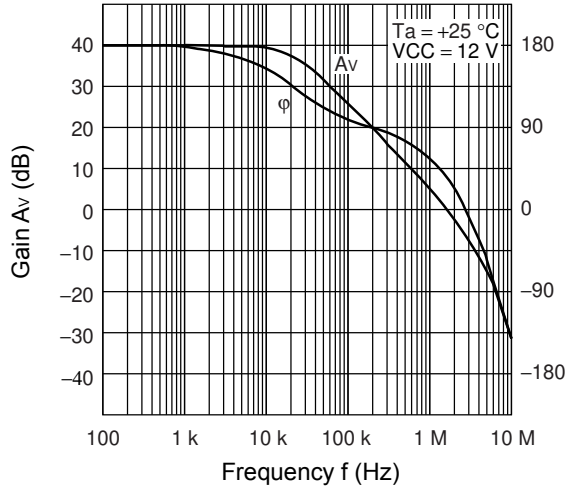

Error Amp (CH2, CH3)
Gain, Phase vs. Frequency

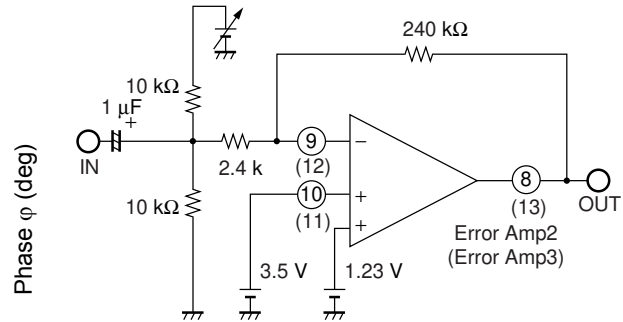
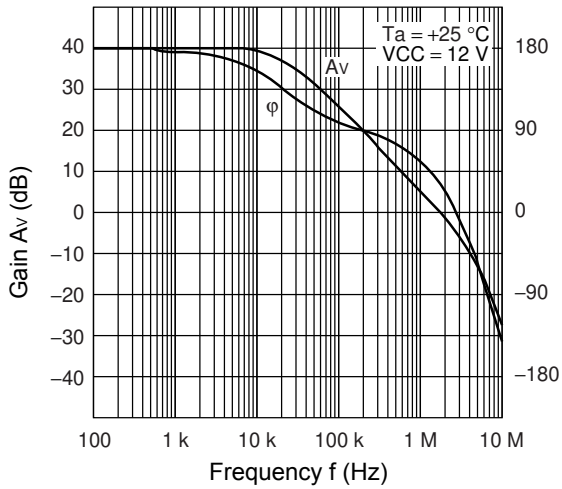

Maximum Power Dissipation vs. Ambient Temperature

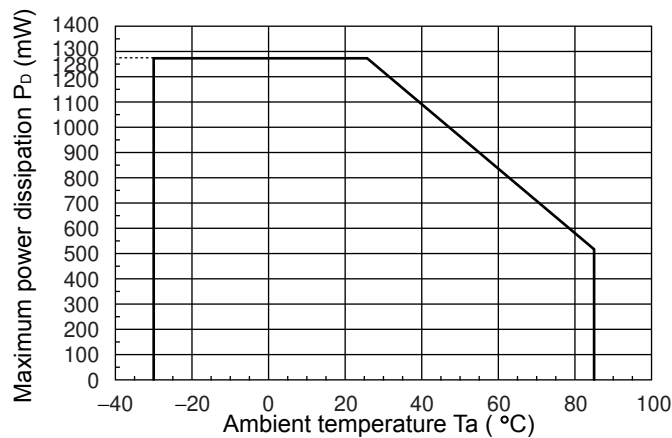

8. Function

8.1 DC/DC Converter Function

8.1.1 Triangular Wave Oscillator Block (OSC)

The triangular wave oscillator incorporates a timing capacitor and a timing resistor connected respectively to the CT terminal (pin 6) and RT terminal (pin 5) to generate triangular oscillation waveform amplitude of 2.0 V to 2.5 V. The triangular waveforms are input to the PWM comparator in the IC.

8.1.2 Error Amplifier Block (Error Amp1, Error Amp2, Error Amp3)

The error amplifier detects the DC/DC converter output voltage and outputs PWM control signals. In addition, an arbitrary loop gain can be set by connecting a feedback resistor and capacitor from the output terminal to inverted input terminal of the error amplifier, enabling stable phase compensation to the system.

Also, it is possible to prevent rush current at power supply start-up by connecting a soft-start capacitor with the CS1 terminal (pin 1), CS2 terminal (pin 10) and CS3 terminal (pin 11) which are the non-inverted input terminal for Error Amp. The use of error Amp for soft-start detection makes it possible for a system to operate on a fixed soft-start time that is independent of the output load on the DC/DC converter.

8.1.3 PWM Comparator Block (PWM Comp.)

The PWM comparator is a voltage-to-pulse width modulator that controls the output duty depending on the input/output voltage. The comparator keeps output transistor on while the error amplifier output voltage remain higher than the triangular wave voltage.

8.1.4 Output Block

The output block is in the totem pole configuration, capable of driving an external P-channel MOS FET.

8.1.5 Bias Voltage Block (VH)

This bias voltage circuit outputs $V_{CC} - 5\text{ V}$ (Typ) as minimum potential of the output circuit.

8.2 Protective Function

8.2.1 Timer Latch Short-circuit Protection Circuit (SCP)

Each channel has a short-circuit detection comparator (SCP Comp.) which constantly compares the error Amp. output level to the reference voltage.

While DC/DC converter load conditions are stable on all channels, the short-circuit detection comparator output remains at "L", and the CSCP terminal is held at "L" level.

If the load condition on a channel changes rapidly due to a short-circuit of the load, causing the output voltage to drop, the output of the short-circuit detection comparator on that channel goes to "H" level. This causes the external short-circuit protection capacitor C_{SCP} connected to the CSCP terminal (pin 14) to be charged.

When the capacitor C_{SCP} is charged to the threshold voltage ($V_{TH} \approx 0.72\text{ V}$), the latch is set and the external FET is turned off (dead time is set to 100 %). At this point, the latch input is closed and the CSCP terminal is held at "L" level.

The latch applied by the timer-latch short-circuit protection circuit can be reset by recycling the power supply (VCC) (See ["Setting Time Constant For Timer-latch Short-circuit Protection Circuit"](#)).

8.2.2 Undervoltage Lockout Protection Circuit Block (UVLO)

The transient state or a momentary decrease in supply voltage, which occurs when the power supply is turned on, may cause the IC to malfunction, resulting in breakdown or degradation of the system. To prevent such malfunctions, under voltage lockout protection circuit detects a decrease in internal reference voltage with respect to the power supply voltage, turns off the output transistor, and sets the dead time to 100% while holding the CSCP terminal (pin 14) at the “L” level.

The circuit restores the output transistor to normal when the supply voltage reaches the threshold voltage of the undervoltage lockout protection circuit.

8.2.3 Protection Circuit Operating Function Table

This table refers to output condition when each protection circuit is operating.

Operating circuit	CH1	CH2	CH3
	OUT1	OUT2	OUT3
Short-circuit protection circuit	H	H	H
Under-voltage lockout circuit	H	H	H

The latch can be reset as follows after the short-circuit protection circuit is actuated.

Recycling VCC resets the latch whenever the short-circuit protection circuit has been actuated.

9. Setting The Output Voltage

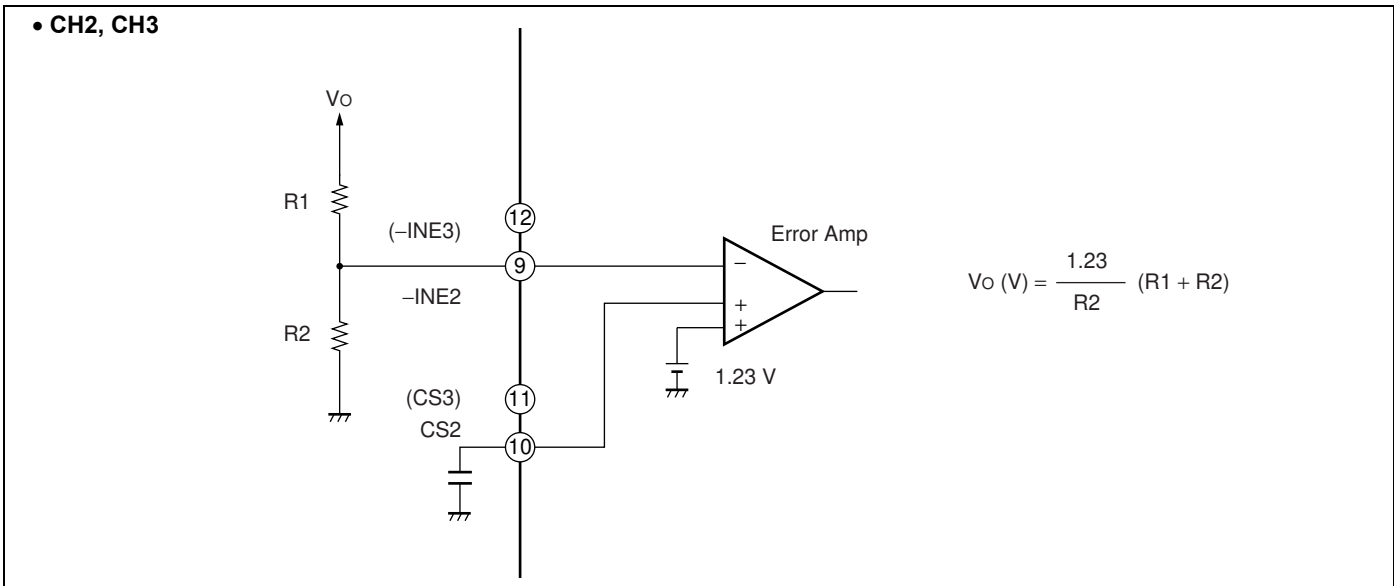
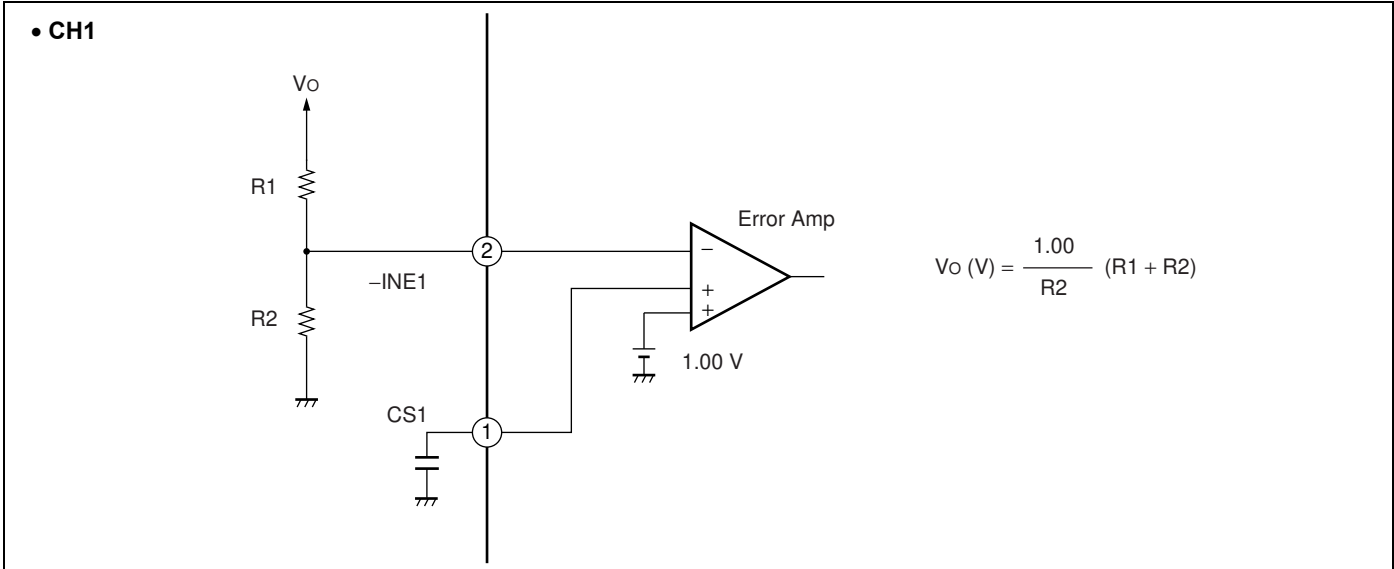

10. Setting The Triangular Oscillation Frequency

The triangular oscillation frequency is determined by the timing capacitor (C_T) connected to the C_T terminal (pin 6) and the timing resistor (R_T) connected to the R_T terminal (pin 5).

Triangular oscillation frequency : fosc

$$f_{osc} \text{ (kHz)} \approx \frac{1200000}{C_T \text{ (pF)} \cdot R_T \text{ (k}\Omega\text{)}}$$

11. Setting The Soft-start And Discharge Times

To prevent rush currents when the IC is turned on, you can set a soft-start by connecting soft-start capacitors (C_{S1} , C_{S2} and C_{S3}) to the CS1 terminal (pin 1) for channel 1, CS2 terminal (pin 10) for channel 2 and CS3 terminal (pin 11) for channel 3 respectively.

Setting each control terminal (\overline{CTLX}) from “H” to “L” starts charging the external soft-start capacitors (C_{S1} , C_{S2} and C_{S3}) connected to the CS1, CS2 and CS3 terminal at about 10 μA . The DC/DC converter output voltage rises in proportion to the CS terminal voltage. Also, soft-start time is obtained by the following formulas.

Soft-start time : t_s (time to output 100%)

CH1 : $t_{s1}[\text{s}] \approx 0.100 \times C_{S1}[\mu\text{F}]$

CH2 : $t_{s2}[\text{s}] \approx 0.123 \times C_{S2}[\mu\text{F}]$

CH3 : $t_{s3}[\text{s}] \approx 0.123 \times C_{S3}[\mu\text{F}]$

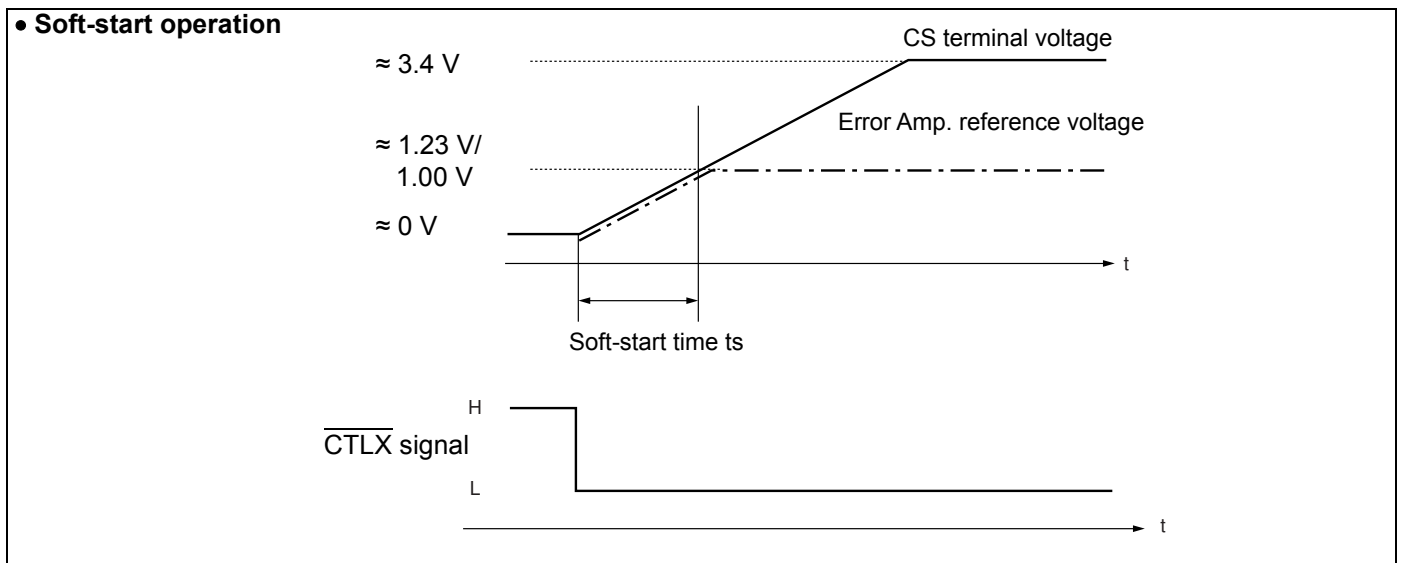
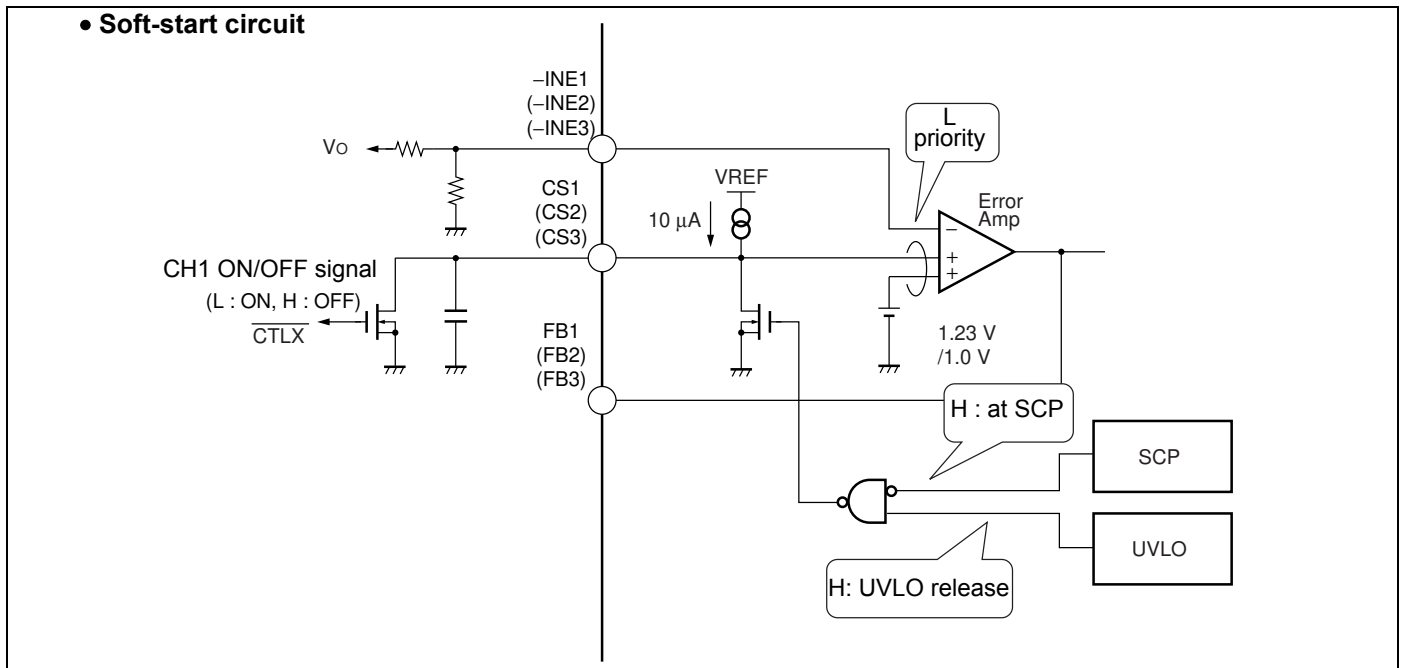

12. Treatment Without Using CS Terminal

When not using the soft-start function, open the CS1 terminal (pin 1) , CS2 terminal (pin 10) and CS3 terminal (pin 11) .

- **Without setting soft-start tme**

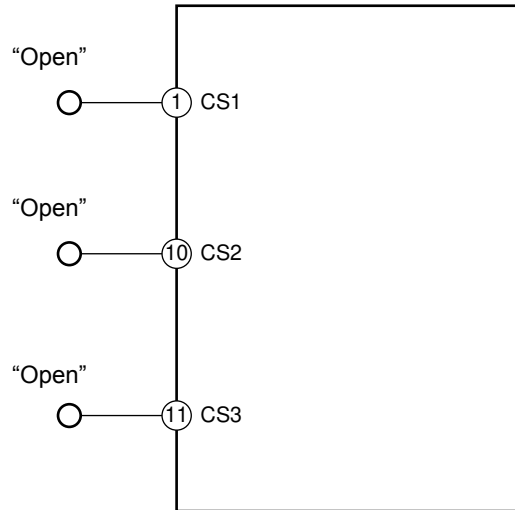

13. Setting Time Constant For Timer-latch Short-circuit Protection Circuit

Each channel uses the short-circuit detection comparator (SCP Comp.) to always compare the error amplifier's output level to the reference voltage.

While DC/DC converter load conditions are stable on all channels, the short-circuit detection comparator output remains at "L" level, and the CSCP terminal (pin 14) is held at "L" level.

If the load condition on a channel changes rapidly due to a short-circuit of the load, causing the output voltage to drop, the output of the short-circuit detection comparator goes to "H" level. This causes the external short-circuit protection capacitor C_{SCP} connected to the CSCP terminal to be charged at 1 μA .

Short-circuit detection time : t_{cscp}

$$t_{cscp}[s] \approx 0.72 \times C_{SCP} [\mu\text{F}]$$

When the capacitor C_{SCP} is charged to the threshold voltage ($V_{TH} \approx 0.72 \text{ V}$), the latch is set and the external FET is turned off (dead time is set to 100 %). At this time, the latch input is closed and the CSCP terminal (pin 14) is held at "L" level.

If any of CH1 to CH3 detects a short circuit, all the channels are stopped.

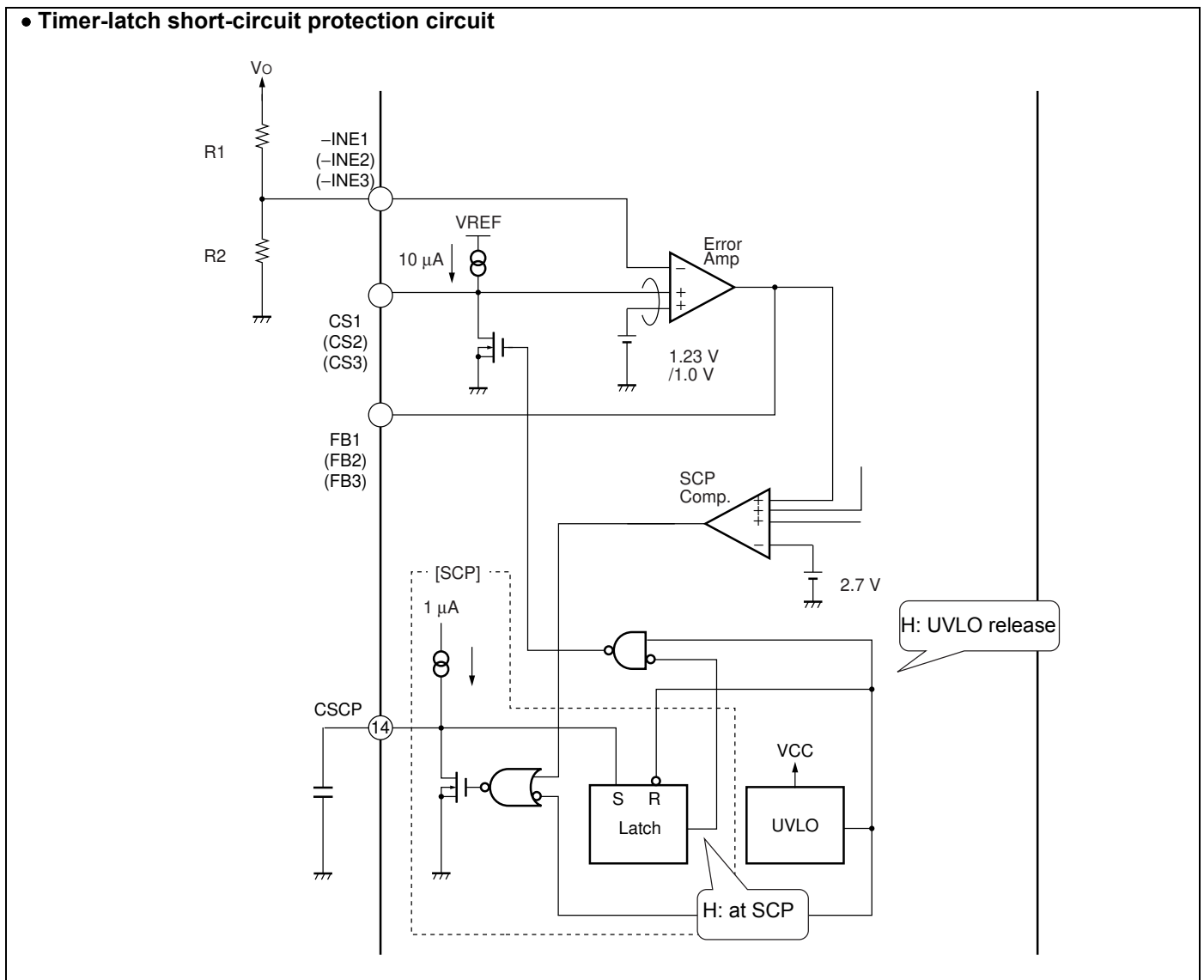

14. Treatment Without Using CSCP Terminal

When not using the timer-latch short-circuit protection circuit, connect the CSCP terminal (pin 14) to GND with the shortest distance.

- Treatment without using CSCP terminal

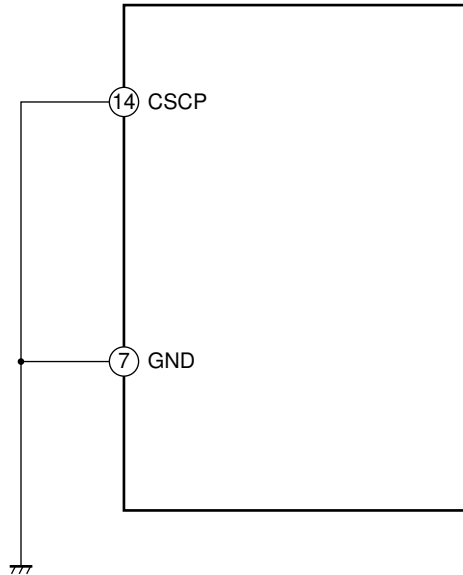

15. I/O Equivalent Circuit

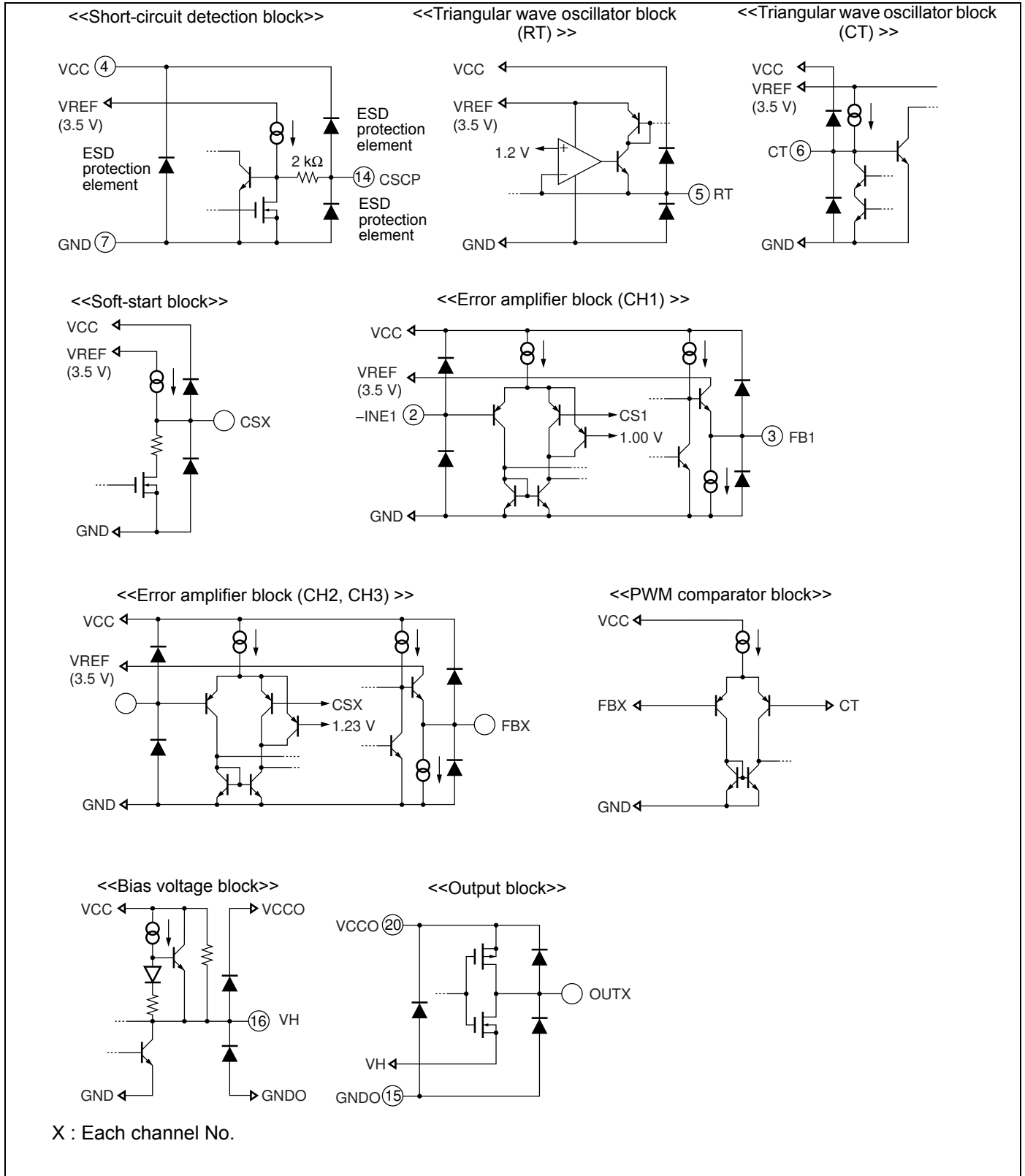

16. Application Example

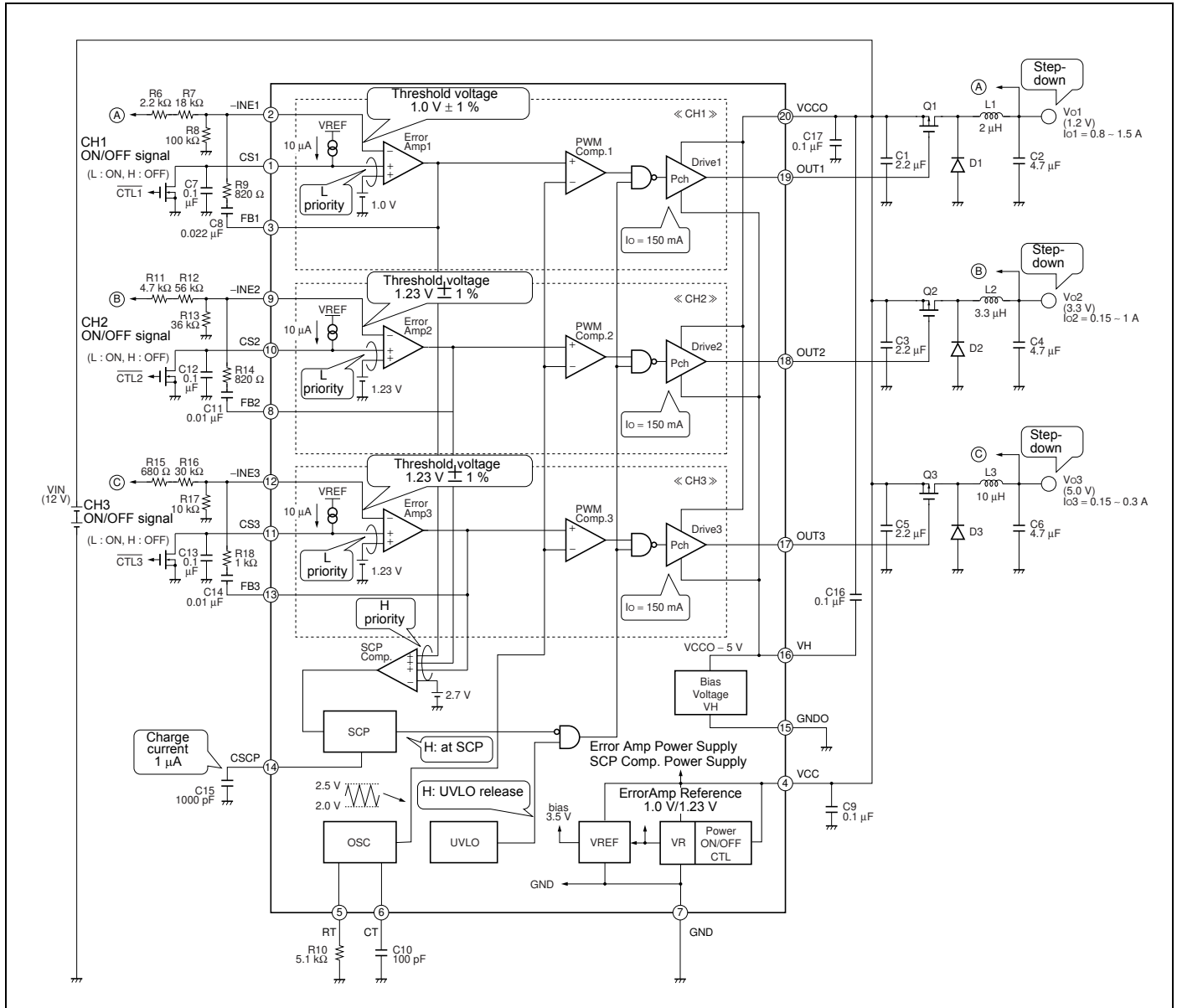

17. Parts List

COMPONENT	ITEM	SPECIFICATION		VENDOR	PARTS No.
Q1, Q2, Q3	Pch FET Pch FET	VDS = - 30 V, ID = - 2.0 A VDS = - 30 V, ID = - 1.0 A		SANYO SANYO	MCH3312 MCH3308
D1, D2 D3	Diode Diode	VF = 0.55 V (Max) , at IF = 2 A VF = 0.4 V (Max) , at IF = 0.5 A		SANYO SANYO	SBE001 SBE005
L1 L2 L3	Inductor Inductor Inductor	2 μ H 3.3 μ H 10 μ H	3 A, 16 m Ω 2.57 A, 21.4 m Ω 1.49 A, 41.2 m Ω	TOKO TOKO TOKO	A916CY-2R0M A916CY-3R3M A916CY-100M
C1, C3, C5 C2, C4, C6 C7, C9, C12 C8 C10 C11, C14 C13, C16, C17 C15	Ceramics Condenser Ceramics Condenser Ceramics Condenser Ceramics Condenser Ceramics Condenser Ceramics Condenser Ceramics Condenser Ceramics Condenser	2.2 μ F 4.7 μ F 0.1 μ F 0.022 μ F 100 pF 0.01 μ F 0.1 μ F 1000 pF	25 V 10 V 50 V 50 V 50 V 50 V 50 V 50 V	TDK TDK TDK TDK TDK TDK TDK TDK	C3216JB1E225K C3216JB1A475M C1608JB1H104K C1608JB1H223K C1608CH1H101J C1608JB1H103K C1608JB1H104K C1608JB1H102K
R6 R7 R8 R9 R10 R11 R12 R13 R14 R15 R16 R17 R18	Resistor Resistor Resistor Resistor Resistor Resistor Resistor Resistor Resistor Resistor Resistor Resistor Resistor	2.2 k Ω 18 k Ω 100 k Ω 820 Ω 5.1 k Ω 4.7 k Ω 56 k Ω 36 k Ω 820 Ω 680 Ω 30 k Ω 10 k Ω 1 k Ω	0.5 % 0.5 % 0.5 % 0.5 % 0.5 % 0.5 % 0.5 % 0.5 % 0.5 % 0.5 % 0.5 % 0.5 % 0.5 %	ssm ssm ssm ssm ssm ssm ssm ssm ssm ssm ssm ssm ssm	RR0816P-222-D RR0816P-183-D RR0816P-104-D RR0816P-821-D RR0816P-512-D RR0816P-472-D RR0816P-563-D RR0816P-363-D RR0816P-821-D RR0816P-681-D RR0816P-303-D RR0816P-103-D RR0816P-102-D

Note :

SANYO : SANYO Electric Co., Ltd.
 TOKO : TOKO Inc.
 TDK : TDK Corporation
 ssm : SUSUMU Co., Ltd.

18. Selection Of Components

■ Pch MOS FET

The Pch MOS FET for switching use should be rated for at least 20 % or more than the maximum input voltage. To minimize continuity loss, use a FET with low $R_{DS(ON)}$ between the drain and source. For high input voltage and high frequency operation, on-cycle switching loss will be higher so that power dissipation must be considered. In this application, the SANYO MCH3312 and MCH3308 are used. Continuity loss, on/off-cycle switching loss and total loss are determined by the following formulas. The selection must ensure that peak drain current does not exceed rated values.

Continuity loss : P_C

$$P_C = I_D^2 \times R_{DS(ON)} \times \text{Duty}$$

On-cycle switching loss : $P_{S(ON)}$

$$P_{S(ON)} = \frac{V_{D(Max)} \times I_D \times t_r \times f_{osc}}{6}$$

Off-cycle switching loss : $P_{S(OFF)}$

$$P_{S(OFF)} = \frac{V_{D(Max)} \times I_{D(Max)} \times t_f \times f_{osc}}{6}$$

Total loss : P_T

$$P_T = P_C + P_{S(ON)} + P_{S(OFF)}$$

Example : Using the MCH3312

■ CH1

Input voltage $V_{IN} = 12\text{ V}$, output voltage $V_o = 1.2\text{ V}$, drain current $I_D = 1.5\text{ A}$, oscillation frequency $f_{osc} = 2350\text{ kHz}$, $L = 2\text{ }\mu\text{H}$, drain-source on resistance $R_{DS(ON)} \approx 180\text{ m}\Omega$, $t_r \approx 2.9\text{ ns}$, $t_f \approx 8.7\text{ ns}$.

Drain current (Max) : $I_{D(Max)}$

$$\begin{aligned} I_{D(Max)} &= I_o + \frac{V_{IN} - V_o}{2L} t_{ON} \\ &= 1.5 + \frac{12 - 1.2}{2 \times 2.0 \times 10^{-6}} \times \frac{1}{2350 \times 10^3} \times 0.1 \\ &\approx \underline{1.61\text{ A}} \end{aligned}$$

Drain current (Min) : $I_{D(Min)}$

$$\begin{aligned} I_{D(Min)} &= I_o - \frac{V_{IN} - V_o}{2L} t_{ON} \\ &= 1.5 - \frac{12 - 1.2}{2 \times 2.0 \times 10^{-6}} \times \frac{1}{2350 \times 10^3} \times 0.1 \\ &\approx \underline{1.39\text{ A}} \end{aligned}$$

$$P_C = I_D^2 \times R_{DS(ON)} \times \text{Duty}$$

$$= 1.5^2 \times 0.18 \times 0.1$$

$$\approx \underline{0.04 \text{ W}}$$

$$P_{S(ON)} = \frac{V_D \times I_D \times t_r \times f_{osc}}{6}$$

$$= \frac{12 \times 1.5 \times 2.9 \times 10^{-9} \times 2350 \times 10^3}{6}$$

$$\approx \underline{0.02 \text{ W}}$$

$$P_{S(OFF)} = \frac{V_D \times I_{D(Max)} \times t_f \times f_{osc}}{6}$$

$$= \frac{12 \times 1.61 \times 8.7 \times 10^{-9} \times 2350 \times 10^3}{6}$$

$$\approx \underline{0.066 \text{ W}}$$

$$P_T = P_C + P_{S(ON)} + P_{S(OFF)}$$

$$\approx 0.04 + 0.02 + 0.066$$

$$\approx \underline{0.126 \text{ W}}$$

The above power dissipation figures for the MCH3312 are satisfied with ample margin at 1.0 W, $T_a = +25^\circ\text{C}$.

■ CH2

Input voltage $V_{IN} = 12 \text{ V}$, output voltage $V_O = 3.3 \text{ V}$, drain current $I_D = 1.0 \text{ A}$, oscillation frequency $f_{osc} = 2350 \text{ kHz}$, $L = 3.3 \mu\text{H}$, drain-source on resistance $R_{DS(ON)} \approx 180 \text{ m}\Omega$, $t_r \approx 2.9 \text{ ns}$, $t_f \approx 8.7 \text{ ns}$.

Drain current (Max) : $I_{D(Max)}$

$$I_{D(Max)} = I_o + \frac{V_{IN} - V_o}{2L} t_{ON}$$

$$= 1 + \frac{12 - 3.3}{2 \times 3.3 \times 10^{-6}} \times \frac{1}{2350 \times 10^3} \times 0.275$$

$$\approx \underline{1.15 \text{ A}}$$

Drain current (Min) : $I_{D(Min)}$

$$I_{D(Min)} = I_o - \frac{V_{IN} - V_o}{2L} t_{ON}$$

$$= 1 - \frac{12 - 3.3}{2 \times 3.3 \times 10^{-6}} \times \frac{1}{2350 \times 10^3} \times 0.275$$

$$\approx \underline{0.85 \text{ A}}$$

$$\begin{aligned}
 P_C &= I_D^2 \times R_{DS(ON)} \times \text{Duty} \\
 &= 1^2 \times 0.18 \times 0.275 \\
 &\approx \underline{0.0495 \text{ W}}
 \end{aligned}$$

$$\begin{aligned}
 P_{S(ON)} &= \frac{V_D \times I_D \times t_r \times f_{osc}}{6} \\
 &= \frac{12 \times 1 \times 2.9 \times 10^{-9} \times 2350 \times 10^3}{6} \\
 &\approx \underline{0.0136 \text{ W}}
 \end{aligned}$$

$$\begin{aligned}
 P_{S(OFF)} &= \frac{V_D \times I_{D(Max)} \times t_f \times f_{osc}}{6} \\
 &= \frac{12 \times 1.15 \times 8.7 \times 10^{-9} \times 2350 \times 10^3}{6} \\
 &\approx \underline{0.047 \text{ W}}
 \end{aligned}$$

$$\begin{aligned}
 P_T &= P_C + P_{S(ON)} + P_{S(OFF)} \\
 &\approx 0.0495 + 0.0136 + 0.047 \\
 &\approx \underline{0.11 \text{ W}}
 \end{aligned}$$

The above power dissipation figures for the MCH3312 are satisfied with ample margin at 1.0 W ($T_a = +25^\circ\text{C}$).

Example : Using the MCH3308

■ CH3

Input voltage $V_{IN} = 12 \text{ V}$, output voltage $V_o = 5.0 \text{ V}$, drain current $I_D = 0.3 \text{ A}$, oscillation frequency $f_{osc} = 2350 \text{ kHz}$, $L = 10 \mu\text{H}$, drain-source on resistance $R_{DS(ON)} \approx 600 \text{ m}\Omega$, $t_r \approx 4 \text{ ns}$, $t_f \approx 4 \text{ ns}$.

Drain current (Max) : $I_{D(Max)}$

$$\begin{aligned}
 I_{D(Max)} &= I_o + \frac{V_{IN} - V_o}{2L} t_{ON} \\
 &= 0.3 + \frac{12 - 5}{2 \times 10 \times 10^{-6}} \times \frac{1}{2350 \times 10^3} \times 0.417 \\
 &\approx \underline{0.36 \text{ (A)}}
 \end{aligned}$$

Drain current (Min) : $I_{D (Min)}$

$$\begin{aligned}
 I_{D (Min)} &= I_o - \frac{V_{IN} - V_o}{2L} t_{ON} \\
 &= 0.3 - \frac{12 - 5}{2 \times 10 \times 10^{-6}} \times \frac{1}{2350 \times 10^3} \times 0.417 \\
 &\approx \underline{0.24 \text{ (A)}}
 \end{aligned}$$

$P_C = I_D^2 \times R_{DS (ON)} \times \text{Duty}$

$$\begin{aligned}
 &= 0.3^2 \times 0.6 \times 0.417 \\
 &\approx \underline{0.023 \text{ W}}
 \end{aligned}$$

$$\begin{aligned}
 P_{S (ON)} &= \frac{V_D \times I_D \times tr \times f_{osc}}{6} \\
 &= \frac{12 \times 0.3 \times 4 \times 10^{-9} \times 2350 \times 10^3}{6} \\
 &\approx \underline{0.0056 \text{ W}}
 \end{aligned}$$

$$\begin{aligned}
 P_{S (OFF)} &= \frac{V_D \times I_{D (Max)} \times tf \times f_{osc}}{6} \\
 &= \frac{12 \times 0.36 \times 4 \times 10^{-9} \times 2350 \times 10^3}{6} \\
 &\approx \underline{0.0068 \text{ W}}
 \end{aligned}$$

$P_T = P_C + P_{S (ON)} + P_{S (OFF)}$

$$\begin{aligned}
 &\approx 0.023 + 0.0056 + 0.0068 \\
 &\approx \underline{0.0354 \text{ W}}
 \end{aligned}$$

The above power dissipation figures for the MCH3308 are satisfied with ample margin at 0.8 W ($T_a = +25^\circ\text{C}$).