



Chipsmall Limited consists of a professional team with an average of over 10 year of expertise in the distribution of electronic components. Based in Hongkong, we have already established firm and mutual-benefit business relationships with customers from,Europe,America and south Asia,supplying obsolete and hard-to-find components to meet their specific needs.

With the principle of “Quality Parts,Customers Priority,Honest Operation,and Considerate Service”,our business mainly focus on the distribution of electronic components. Line cards we deal with include Microchip,ALPS,ROHM,Xilinx,Pulse,ON,Everlight and Freescale. Main products comprise IC,Modules,Potentiometer,IC Socket,Relay,Connector.Our parts cover such applications as commercial,industrial, and automotives areas.

We are looking forward to setting up business relationship with you and hope to provide you with the best service and solution. Let us make a better world for our industry!



Contact us

Tel: +86-755-8981 8866 Fax: +86-755-8427 6832

Email & Skype: info@chipsmall.com Web: www.chipsmall.com

Address: A1208, Overseas Decoration Building, #122 Zhenhua RD., Futian, Shenzhen, China



This specification applies to the electret condenser microphone outlined within this document.

Model Number: **MB6022ASC-1L**

I. Electrical Characteristics Test Condition (Vs= 2.0 V, RL= 2.2 k ohm, Ta=20°C, RH=65%)

| ITEM | SYMBOL | TEST CONDITION | MINIMUM | STANDARD | MAXIMUM | UNITS |
|-----------------------|---------|----------------------------------|------------------|----------|---------|-----------------|
| Sensitivity | S | f=1kHz, Pin=1Pa | -45 | -42 | -39 | dB 0dB=1V/Pa |
| Impedance | Zout | f=1kHz, Pin=1Pa | | | 2.2 | k Ω |
| Directivity | | | OMNI-DIRECTIONAL | | | |
| Current Consumption | I | | | | 0.5 | mA |
| S/N Ratio | S/N (A) | f=1kHz, Pin=1Pa A Curve | 60 | | | dB |
| Sensitivity Reduction | Δ S | f=1kHz, Pin=1Pa Vs= 2.0 - 1.5 | | | -3 | dB |
| Frequency Range | | | 100-10,000 | | | Hz |

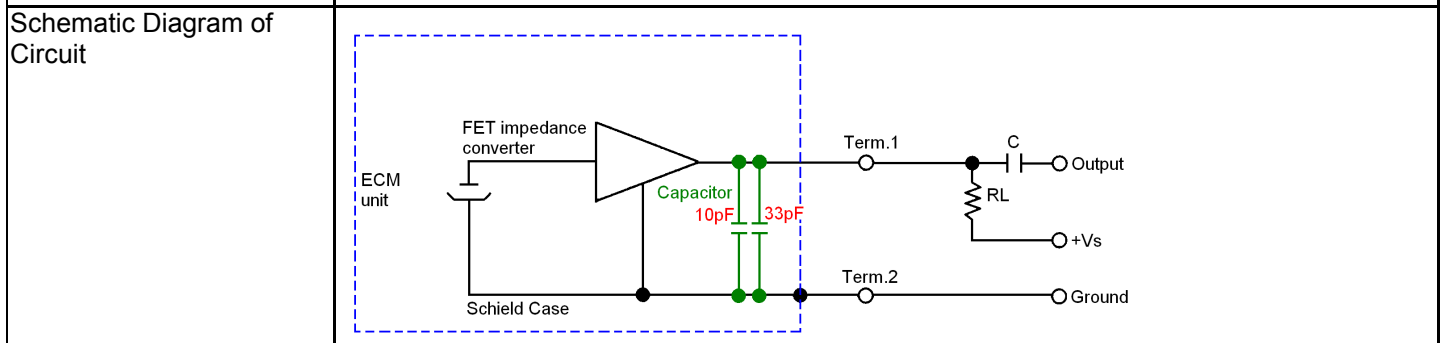
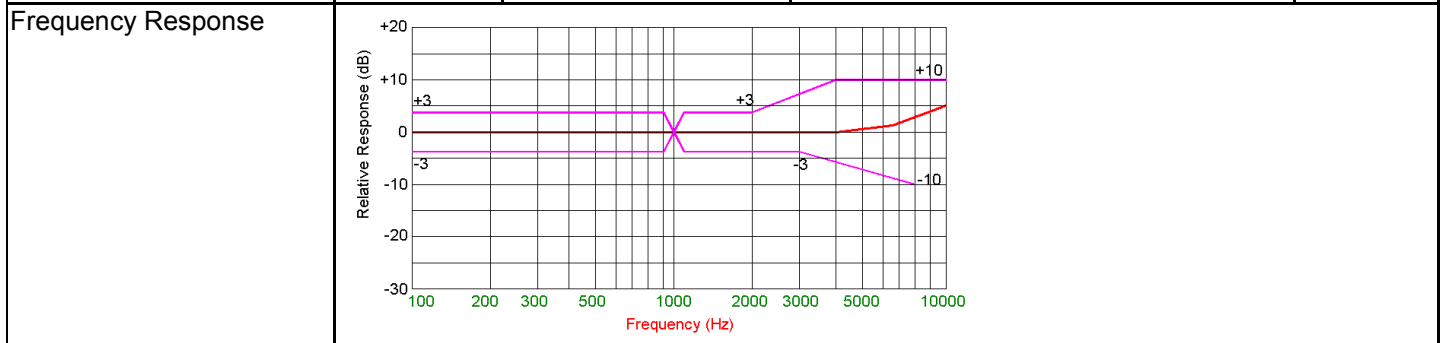

II. Mechanical Characteristics

| | | | |
|------------------------------|---|---------------------------|-----------------------------|
| Dimensions | ∅ 6 x 2.2 | See Drawing in Section IV | |
| Weight | Less than 0.2g | | |
| Soldering Heat Shock | To be no interference in operation after soldering temperature exposure at 330°C +/-10°C for 2 +/- 0.5 seconds. | | |
| Terminal Mechanical Strength | To be no interference in operation after pulling terminal 0.5kg force for 1 minute | | |
| Absolute Maximum Ratings | Operating Voltage | Storage Temperature Range | Operation Temperature Range |
| | Vs (V) | Tstg °C | Tope °C |
| | 10 | -40°C to +85°C | -30°C to +70°C |

III. Reliability Tests

Note: After any of the following tests performed, the sensitivity of the microphone unit shall not deviate more than $\pm 3\text{dB}$ from its initial value. The microphone shall maintain its initial operation and appearance. Measurements for tests with thermal requirements are to be done after 2hrs of conditioning at 20°C .

| | | |
|------------------------|---|---|
| Vibration Test | The microphone to have no interference in operation after vibrations, 10Hz to 55Hz for 1minute full amplitude 1.52mm, for 2 hours at three axes. | |
| Drop Test | The microphone unit must operate when dropped three times once on each axis from a height of 1m onto a metal plate. | |
| Temperature Test | High | The microphone unit must operate within its sensitivity specifications after subjected to the following conditions: $+85^\circ\text{C}$ for 240 hrs, and exposed to room temperature for 2 hrs. |
| | Low | The microphone unit must operate within its sensitivity specifications after subjected to the following conditions: -40°C for 240 hrs, and exposed to room temperature for 2 hrs. |
| Humidity Test | $+60^\circ\text{C}$ at 95%RH for 240 hrs | |
| Temperature Cycle Test | After exposure at -40°C for 45 minutes, at $+20^\circ\text{C}$ for 10 minutes, at $+85^\circ\text{C}$ for 45 minutes, at $+20^\circ\text{C}$ for 10 minutes, 27 cycles. (The measurement to be done after 2 hrs of conditioning at $+20^\circ\text{C}$.) | |

IV. Dimensional Drawing

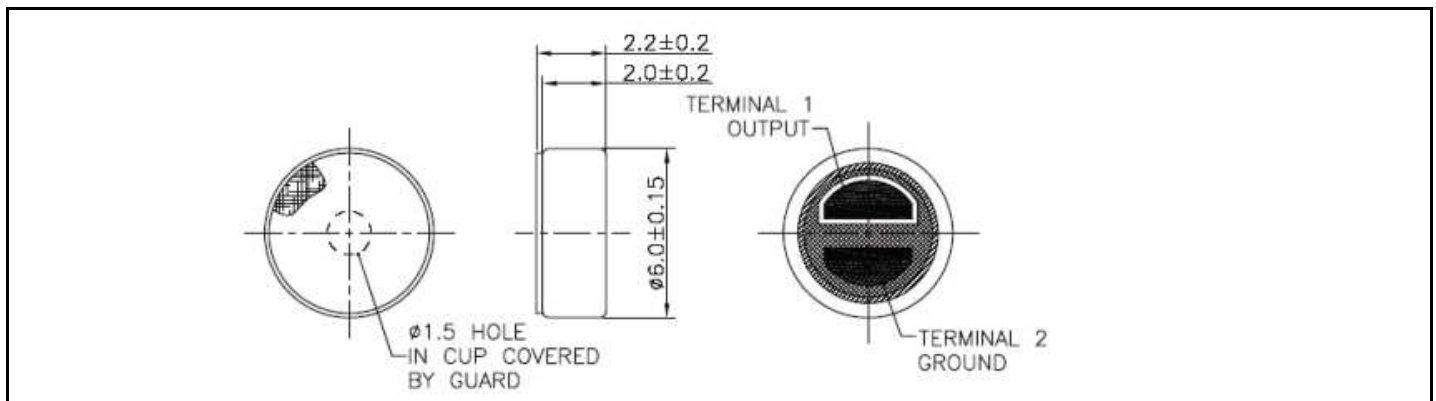

V. Other



The information contained in this literature is based on our experience to date and is believed to be reliable and it is subject to change without notice. It is intended as a guide for use by persons having technical skill at their own discretion and risk. We do not guarantee favorable results or assume any liability in connection with its use. Dimensions contained herein are for reference purposes only. For specific dimensional requirements consult factory. This publication is not to be taken as a license to operate under, or recommendation to infringe any existing patents. This supersedes and voids all previous literature.