



Chipsmall Limited consists of a professional team with an average of over 10 year of expertise in the distribution of electronic components. Based in Hongkong, we have already established firm and mutual-benefit business relationships with customers from,Europe,America and south Asia,supplying obsolete and hard-to-find components to meet their specific needs.

With the principle of “Quality Parts,Customers Priority,Honest Operation,and Considerate Service”,our business mainly focus on the distribution of electronic components. Line cards we deal with include Microchip,ALPS,ROHM,Xilinx,Pulse,ON,Everlight and Freescale. Main products comprise IC,Modules,Potentiometer,IC Socket,Relay,Connector.Our parts cover such applications as commercial,industrial, and automotives areas.

We are looking forward to setting up business relationship with you and hope to provide you with the best service and solution. Let us make a better world for our industry!



## Contact us

Tel: +86-755-8981 8866 Fax: +86-755-8427 6832

Email & Skype: info@chipsmall.com Web: www.chipsmall.com

Address: A1208, Overseas Decoration Building, #122 Zhenhua RD., Futian, Shenzhen, China



## “FLAT PACK” RECTANGULAR INDUCTIVE PROXIMITY SENSORS

- IDEAL FOR LIMITED SPACE APPLICATIONS
- SENSE FERROUS & NON-FERROUS METAL OBJECTS TO “ZERO SPEED”
- 3-WIRE NPN TRUE OPEN COLLECTOR OUTPUTS
- 2 SIZES & SENSING DISTANCES FOR APPLICATION VERSATILITY
- L.E.D. TARGET INDICATOR



### DESCRIPTION & OPERATION

Inductive Proximity Sensors detect the presence of metal objects that come within range of their oscillating field and provide target detection to “zero speed”. Internally, an oscillator creates a high frequency electromagnetic field (RF) that is radiated from the coil and out from the sensor face (See Figure 1). When a metal object enters this field, eddy currents are induced into the object.

As the metal moves closer to the sensor, these eddy currents increase and result in an absorption of energy from the coil that dampens the oscillator amplitude until it finally stops.

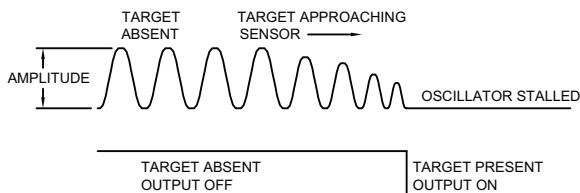
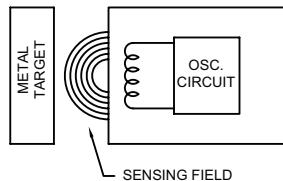

Figure 1

### MODELS PSAFP1 & PSAFP2

In addition to the coil and oscillator circuit, the 3-wire Models PSAFP1 and PSAFP2 each contain a Detector Circuit and NPN Transistor Output (See Figure 2). In these units, the Detector Circuit senses when the oscillator stops, and turns on the Output Transistor that controls the load. The Detector Circuit also turns on an integrally case mounted L.E.D., visually indicating when a metal object is sensed.

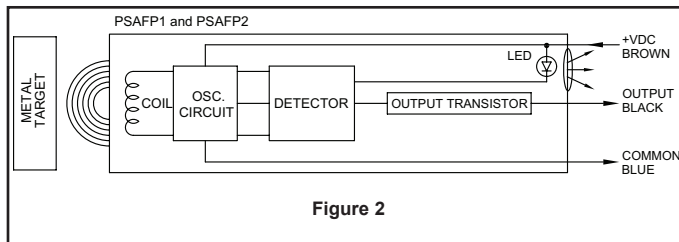

Figure 2

#### LED STATES

- LED ON (GREEN) POWER ON
- LED ON (YELLOW) OUTPUT ENERGIZED
- LED ON (FLASHING GREEN) SHORT CIRCUIT WARNING

These Inductive Proximity Sensors have a maximum sensing distance of 0.078" (2 mm) and 0.393" (10 mm) respectively, and operate over a wide power supply range (See Specifications Below). They are each housed in plastic with a top active face. The NPN transistor outputs are true open collector and are compatible with most Red Lion counter and rate meter input circuits. Maximum sensing frequencies are 2 KHz and 500 Hz respectively. In addition, the outputs are overload and short circuit protected. These sensors are shielded for flush mounting in metal applications.

### PSAFP1 AND PSAFP2 SPECIFICATIONS

	PSAFP100	PSAFP200
1. Power Supply:	+10 to +30 VDC @ 15 mA max.	
	REVERSE POLARITY PROTECTION	
2. Maximum Switching Frequency:	2 KHz	500 Hz
3. Output:	NPN Open Collector Output, Overload and Short Circuit protected.	
	V <sub>SAT</sub> = 1.8 V @ 150 mA max. load	V <sub>SAT</sub> = 1.8 V @ 200 mA max. load
4. Maximum Sensing Distance:	0.078" (2 mm)	0.393" (10 mm)
5. Wire Color Code:	Brown = +VDC; Blue = Common; Black = Output	
6. Operating Temperature:	-25° to +85°C (-14° to +185°F)	-25° to +70°C (-14° to +158°F)
7. Construction:	NEMA 1, 3, 4, 6, 13 and IEC IP 67	
8. Trigger Current for Overload Protection:	170 mA	220 mA

### TYPICAL HOOKUP

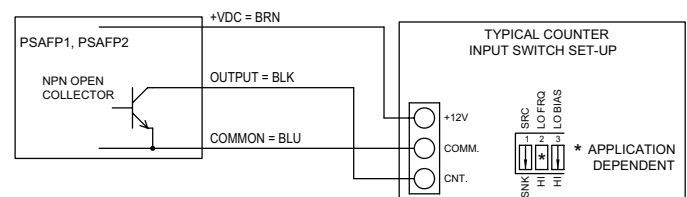

## DIMENSIONS In inches (mm)

### PSAFP100

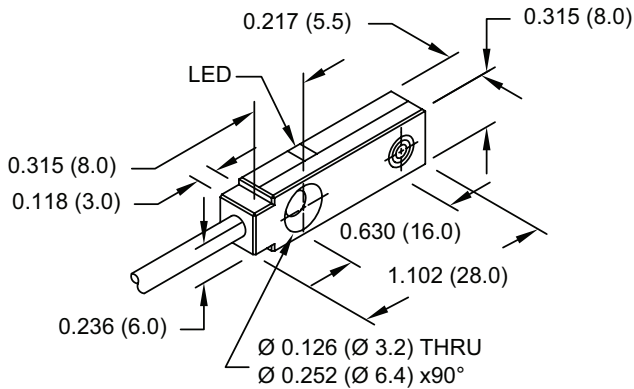

### PSAFP200

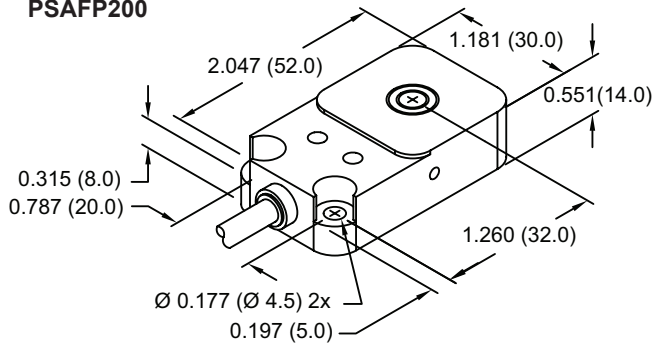

#### Notes:

1. PSAFP100 Housing: Plastic, PA12-GF30  
Cable: 2 meter standard length
2. PSAFP200 Housing: Plastic, PBT-GF30-VO  
Cable: 2 meter standard length

## SELECTION & APPLICATION OF PROXIMITY SENSORS

Selection of the proper proximity sensor depends on the size, material, and spacing of the target being sensed and the sensing distance that can be maintained. The maximum sensing distance is defined as the distance when the sensor is just close enough to detect a ferrous target whose diameter is equal to or greater than the sensor diameter. In actual application, the sensing distance should be between 50 to 80% of the maximum sensing range to assure reliable detection. For target sizes smaller than the sensor diameter, the maximum sensing distance can be estimated from the curve (See Figure 3). A further reduction factor must also be applied if the target material is non-ferrous metal (See Figure 4). Ideally, spacing between adjacent targets should be at least one sensor diameter so that the first target completely leaves the sensors field before the next target appears. Individual targets can still be resolved as separate objects if this spacing is reduced to 70 or 75% of the sensor diameter, however, this can introduce a minimum limit on sensing distance that makes adjustment more critical. All proximity sensors are internally shielded which allows the sensor face to be flush mounted in metal applications without reducing sensing distance. In applications where proximity sensors must be placed next to each other, a distance of at least 1 sensor diameter should separate sensors to eliminate any frequency interference (See Mounting below).

### MAXIMUM SENSING DISTANCE REDUCTION FACTORS

Reduction in the maximum sensing distance due to decrease in diameter of ferrous targets.

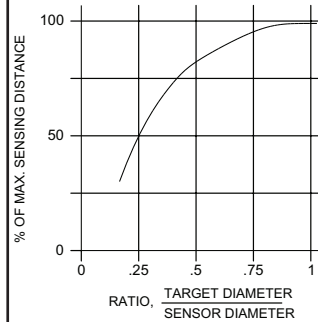
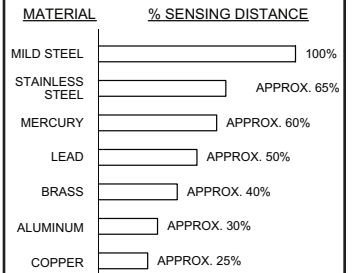

Figure 3

Typical reduction factors for various non-ferrous targets with diameters equal to or greater than sensor diameter.



Nominal sensing range x % sensing distance = actual sensing range

Figure 4

### PSAFP200 MOUNTING

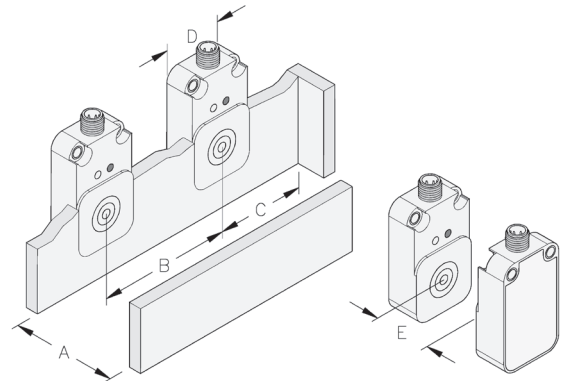

A	B	C	D	E
30.00 mm	45.00 mm	30.00 mm	30.00 mm	60.00 mm

PSAFP100 and PSAFP200 outputs are NPN open collector outputs. A PSAFP100 and PSAFP200 may be used as an input to more than 1 indicator or control only if the respective power supplies of each unit are "unregulated" and can load share. It is recommended to use only one power supply for sensor power. An indicator or control with a regulated power supply may not be paralleled.

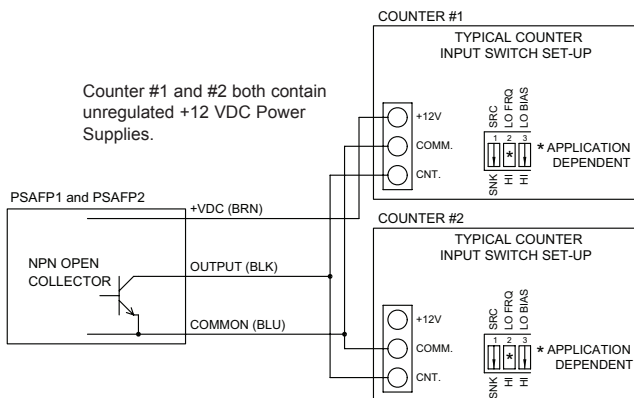

# MODELS MB7 & MB8 MOUNTING ACCESSORIES FOR PSAFP200

## MB700000

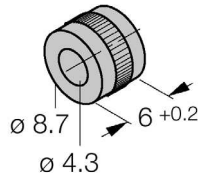

- MOUNTING SPACER
- FOR MOUNTING WITH ACTIVE FACE DOWNWARDS
- METAL, Cu2n

## MB800000

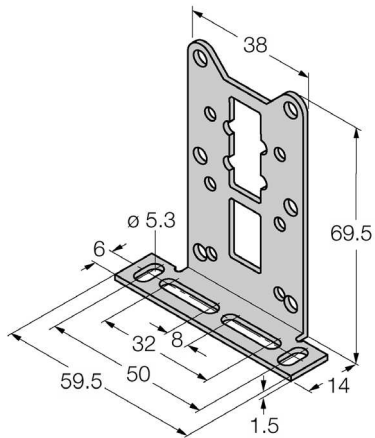

- MOUNTING BRACKET
- STAINLESS STEEL: VA 1.4301

The Model MB7 and MB8 mounting accessories are designed to provide easy mounting and adjustment of the PSAFP200.

## ORDERING INFORMATION

MODEL NO.	DESCRIPTION	PART NUMBER
PSAFP1	2 mm Flat Pack Rectangular Proximity Sensor	PSAFP100
PSAFP2	10 mm Flat Pack Rectangular Proximity Sensor	PSAFP200
MB7	Spacer for PSAFP200	MB700000
MB8	Mounting Bracket for PSAFP200	MB800000



Do not dispose of unit in trash - Recycle

### **LIMITED WARRANTY**

The Company warrants the products it manufactures against defects in materials and workmanship for a period limited to two years from the date of shipment, provided the products have been stored, handled, installed, and used under proper conditions. The Company's liability under this limited warranty shall extend only to the repair or replacement of a defective product, at The Company's option. The Company disclaims all liability for any affirmation, promise or representation with respect to the products.

The customer agrees to hold Red Lion Controls harmless from, defend, and indemnify RLC against damages, claims, and expenses arising out of subsequent sales of RLC products or products containing components manufactured by RLC and based upon personal injuries, deaths, property damage, lost profits, and other matters which Buyer, its employees, or sub-contractors are or may be to any extent liable, including without limitation penalties imposed by the Consumer Product Safety Act (P.L. 92-573) and liability imposed upon any person pursuant to the Magnuson-Moss Warranty Act (P.L. 93-637), as now in effect or as amended hereafter.

No warranties expressed or implied are created with respect to The Company's products except those expressly contained herein. The Customer acknowledges the disclaimers and limitations contained herein and relies on no other warranties or affirmations.

Red Lion Controls  
Headquarters  
20 Willow Springs Circle  
York PA 17406  
Tel +1 (717) 767-6511  
Fax +1 (717) 764-0839

Red Lion Controls  
Europe  
Softwareweg 9  
NL - 3821 BN Amersfoort  
Tel +31 (0) 334 723 225  
Fax +31 (0) 334 893 793

Red Lion Controls  
India  
201-B, 2nd Floor, Park Centra  
Opp 32 Mile Stone, Sector-30  
Gurgaon-122002 Haryana, India  
Tel +91 984 487 0503

Red Lion Controls  
China  
Unit 302, XinAn Plaza  
Building 13, No.99 Tianzhou Road  
ShangHai, P.R. China 200223  
Tel +86 21 6113 3688  
Fax +86 21 6113 3683