



Chipsmall Limited consists of a professional team with an average of over 10 year of expertise in the distribution of electronic components. Based in Hongkong, we have already established firm and mutual-benefit business relationships with customers from,Europe,America and south Asia,supplying obsolete and hard-to-find components to meet their specific needs.

With the principle of “Quality Parts,Customers Priority,Honest Operation,and Considerate Service”,our business mainly focus on the distribution of electronic components. Line cards we deal with include Microchip,ALPS,ROHM,Xilinx,Pulse,ON,Everlight and Freescale. Main products comprise IC,Modules,Potentiometer,IC Socket,Relay,Connector.Our parts cover such applications as commercial,industrial, and automotives areas.

We are looking forward to setting up business relationship with you and hope to provide you with the best service and solution. Let us make a better world for our industry!



Contact us

Tel: +86-755-8981 8866 Fax: +86-755-8427 6832

Email & Skype: info@chipsmall.com Web: www.chipsmall.com

Address: A1208, Overseas Decoration Building, #122 Zhenhua RD., Futian, Shenzhen, China



Spread Spectrum Clock Generator

MB88151A is a clock generator for EMI (Electro Magnetic Interference) reduction. The peak of unnecessary radiation noise (EMI) can be attenuated by making the oscillation frequency slightly modulate periodically with the internal modulator. It corresponds to both of the center spread which modulates frequency in modulation off as Middle Centered and down spread which modulates so as not to exceed frequency in modulation off.

Features

	MB88151A-100/101 (multiply-by-1)	MB88151A-200/201 (multiply-by-2)	MB88151A-400/401 (multiply-by-4)	MB88151A-500/501 (multiply-by-1/2)	MB88151A-800/801 (multiply-by-8)
Input frequency/ Output frequency	16.6 MHz to 33.4 MHz/ 16.6 MHz to 33.4 MHz	16.6 MHz to 33.4 MHz/ 33.2 MHz to 66.8 MHz	16.6 MHz to 33.4 MHz/ 66.4 MHz to 133.6 MHz	16.6 MHz to 33.4 MHz/ 8.3 MHz to 16.7 MHz	8.3 MHz to 16.7 MHz 66.4 MHz to 133.6 MHz
Modulation clock cycle-cycle jitter	Less than 100 ps	Less than 100 ps	Less than 150 ps	Less than 200 ps	Less than 150 ps

- Modulation rate : $\pm 0.5\%$, $\pm 1.5\%$ (Center spread), $- 1.0\%$, $- 3.0\%$ (Down spread)
- Equipped with oscillation circuit : Range of oscillation 8.3 MHz to 33.4 MHz
- Modulation clock output Duty : 40% to 60%
- Low current consumption by CMOS process : 5 mA (24 MHz : Typ-sample, no load)
- Power supply voltage : $3.3\text{ V} \pm 0.3\text{ V}$
- Operating temperature : $- 40\text{ }^{\circ}\text{C}$ to $+ 85\text{ }^{\circ}\text{C}$
- Package : SOP 8-pin

Contents

Product Lineup	3	Electrical Characteristics	12
Pin Assignment	3	Output Clock Duty Cycle (tdcc = tb/ta)	15
Pin Description	3	Input Frequency (fin = 1/tin)	15
I/O Circuit Type	4	Output Slew Rate (SR)	15
Handling Devices	6	Cycle-cycle Jitter (tjc = tn - tn+1)	16
Preventing Latch-up	6	Modulation Waveform	17
Handling unused pins	6	Lock-up Time	18
The attention when the external clock is used	6	Oscillation Circuit	20
Power supply pins	6	Interconnection Circuit Example	21
Oscillation circuit	6	Spectrum Example Characteristics	22
Block Diagram	7	Ordering Information	23
Pin Setting	8	Package Dimension	24
Absolute Maximum Ratings	10	Document History	25
Recommended Operating Conditions	11	Sales, Solutions, and Legal Information	26

1. Product Lineup

MB88151A has five kinds of multiplication type.

Product	Input frequency range	Multiplier ratio	Output frequency range
MB88151A-100/101	16.6 MHz to 33.4 MHz	Multiply-by-1	16.6 MHz to 33.4 MHz
MB88151A-200/201		Multiply-by-2	33.2 MHz to 66.8 MHz
MB88151A-400/401		Multiply-by-4	66.4 MHz to 133.6 MHz
MB88151A-500/501		Multiply-by-1/2	8.3 MHz to 16.7 MHz
MB88151A-800/801	8.3 MHz to 16.7 MHz	Multiply-by-8	66.4 MHz to 133.6 MHz

2. Pin Assignment

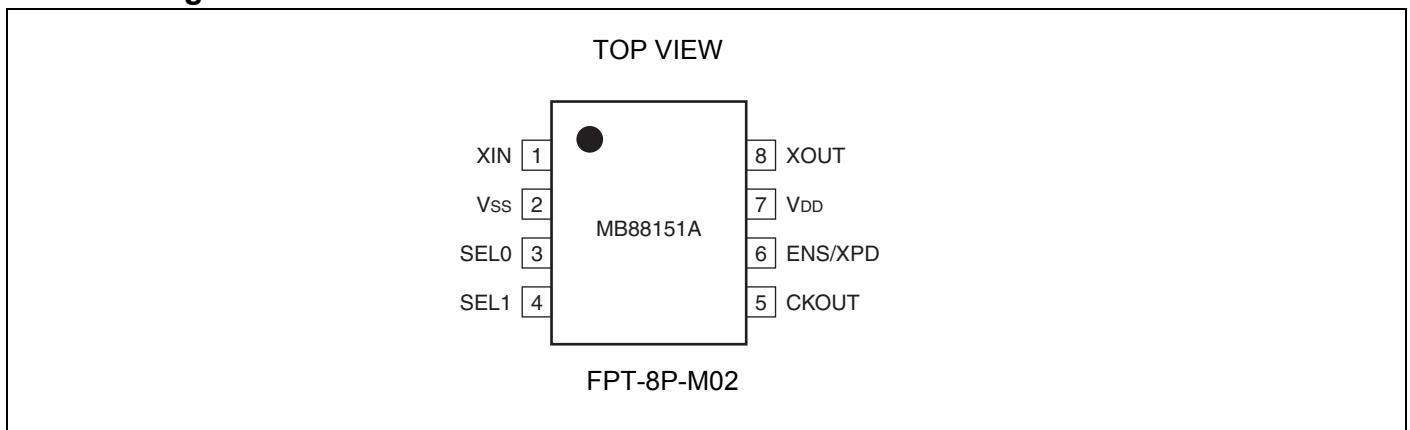

3. Pin Description

Pin name	I/O	Pin no.	Description
XIN	I	1	Resonator connection pin/clock input pin
V _{SS}	—	2	GND pin
SEL0	I	3	Modulation rate setting pin
SEL1	I	4	Modulation rate setting pin
CKOUT	O	5	Modulated clock output pin
ENS/XPD	I	6	Modulation enable setting pin (with pull-up resistance)/ Power down pin (with pull-up resistor)*
V _{DD}	—	7	Power supply voltage pin
XOUT	O	8	Resonator connection pin

* : XPD = 800 kΩ pull-up resistor at “L”

4. I/O Circuit Type

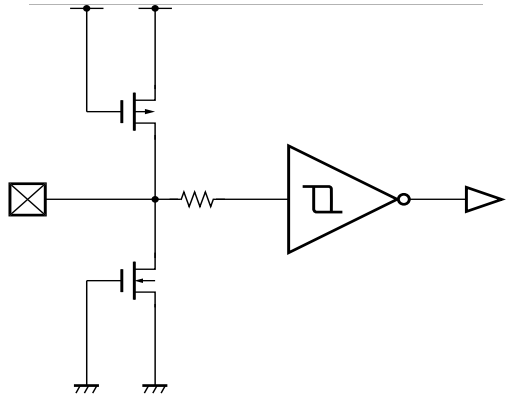
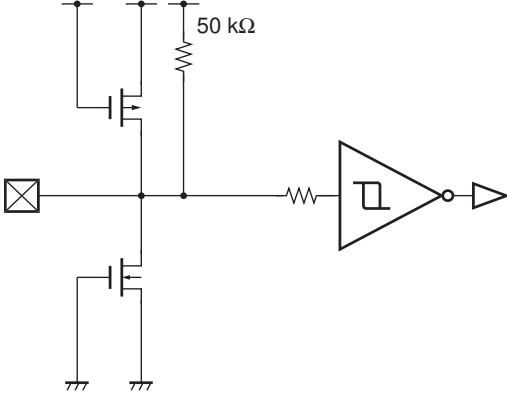
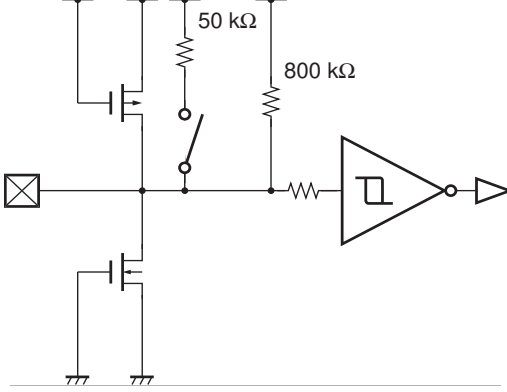
Pin	Circuit type	Remarks
SEL0, SEL1		CMOS hysteresis input
ENS		<ul style="list-style-type: none"> ■ With 50 kΩ pull-up resistors ■ CMOS hysteresis input
XPD		<ul style="list-style-type: none"> ■ With 50 kΩ + 800 kΩ pull-up resistors <p>Note : If “L” is input to XPD, 50 kΩ pull-up resistor is disconnected.</p> <ul style="list-style-type: none"> ■ CMOS hysteresis input

(Continued)

(Continued)

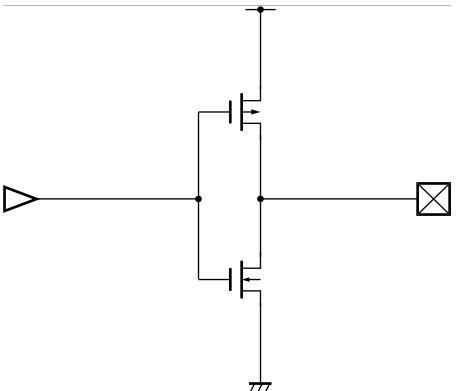
Pin	Circuit type	Remarks
CKOUT		<ul style="list-style-type: none"> ■ CMOS output ■ $I_{OL} = 4 \text{ mA}$

Note : For XIN and XOUT pins, refer to "Oscillation Circuit".

5. Handling Devices

5.1 Preventing Latch-up

A latch-up can occur if, on this device, (a) a voltage higher than V_{DD} or a voltage lower than V_{SS} is applied to an input or output pin or (b) a voltage higher than the rating is applied between V_{DD} pin and V_{SS} pin. The latch-up, if it occurs, significantly increases the power supply current and may cause thermal destruction of an element. When you use this device, be very careful not to exceed the maximum rating.

5.2 Handling unused pins

Do not leave an unused input pin open, since it may cause a malfunction. Handle by, using a pull-up or pull-down resistor.

Unused output pin should be opened.

5.3 The attention when the external clock is used

Input the clock to XIN pin, and XOUT pin should be opened when you use the external clock.

Please pay attention so that an overshoot and an undershoot do not occur to an input clock of XIN pin.

5.4 Power supply pins

Please design connecting the power supply pin of this device by as low impedance as possible from the current supply source.

We recommend connecting electrolytic capacitor (about 10 μF) and the ceramic capacitor (about 0.01 μF) in parallel between V_{SS} pin and V_{DD} pin near the device, as a bypass capacitor.

5.5 Oscillation circuit

Noise near the XIN and XOUT pins may cause the device to malfunction. Design printed circuit boards so that electric wiring of XIN or XOUT pin and the resonator do not intersect other wiring.

Design the printed circuit board that surrounds the XIN and XOUT pins with ground.

6. Block Diagram

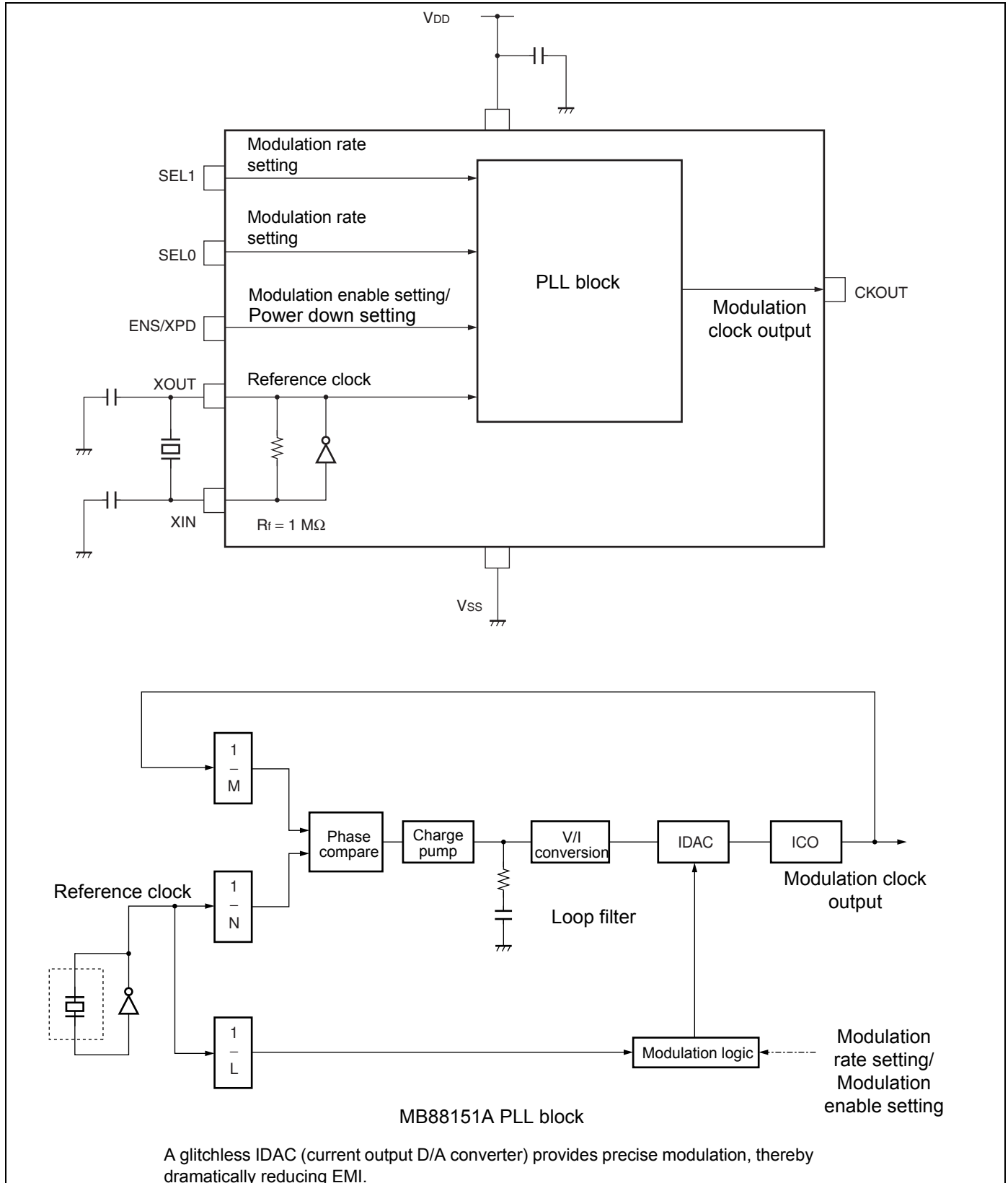

7. Pin Setting

When changing the pin setting, the stabilization wait time for the modulation clock is required. The stabilization wait time for the modulation clock take the maximum value of “[Electrical Characteristics AC Characteristics Lock-up time](#)”.

ENS modulation enable setting (MB88151A-100/200/400/500/800)

ENS	Modulation
L	No modulation
H	Modulation

Note : Spectrum does not spread when “L” is set to ENS. The clock with low jitter can be obtained. Because of ENS has Pull-up resistance, spectrum spread when “H” is set to it or open the terminal.

XPD Power down setting (MB88151A-101/201/401/501/801)

XPD	Status
L	Power down Status
H	Operating status

Note : CKOUT of output pins are fixed to “L” output during power down.

SEL0, SEL1 Modulation rate setting

SEL1	SEL0	Modulation rate	Modulation type
L	L	± 1.5%	Center spread
L	H	± 0.5%	Center spread
H	L	– 1.0%	Down spread
H	H	– 3.0%	Down spread

Note : The modulation rate can be changed at the level of the terminal.

■ Center spread

Spectrum is spread (modulated) by centering on the frequency in modulation off.

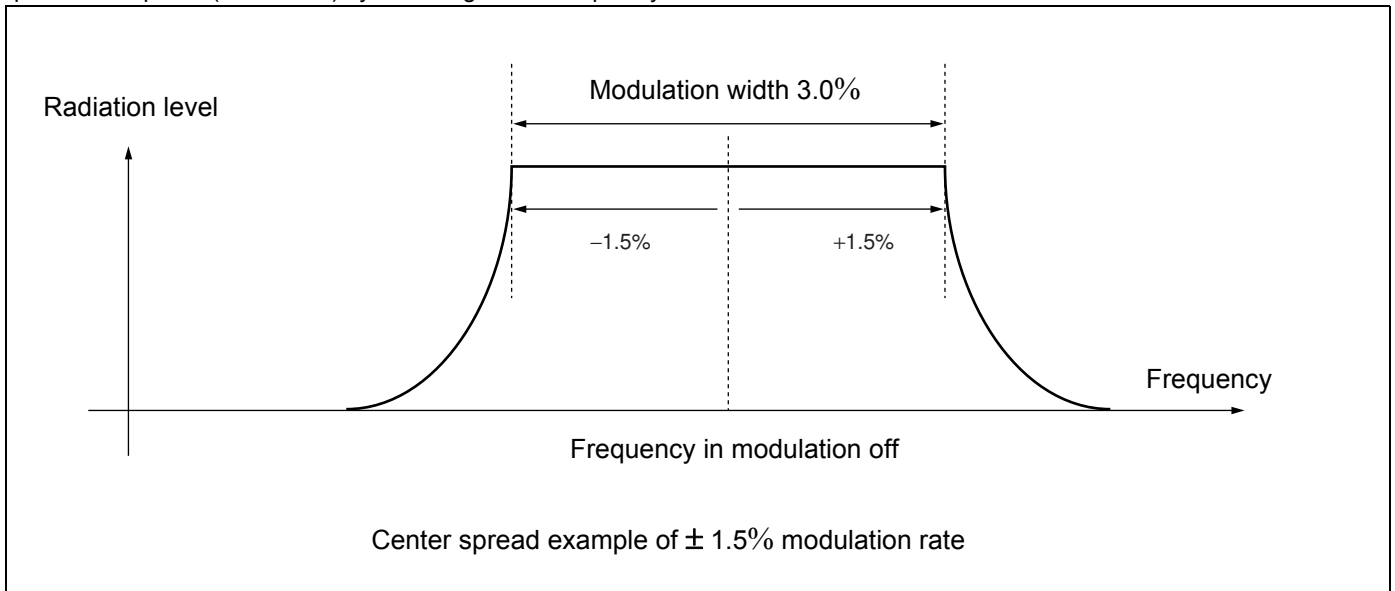

■ Down spread

Spectrum is spread (modulated) below the frequency in modulation off.

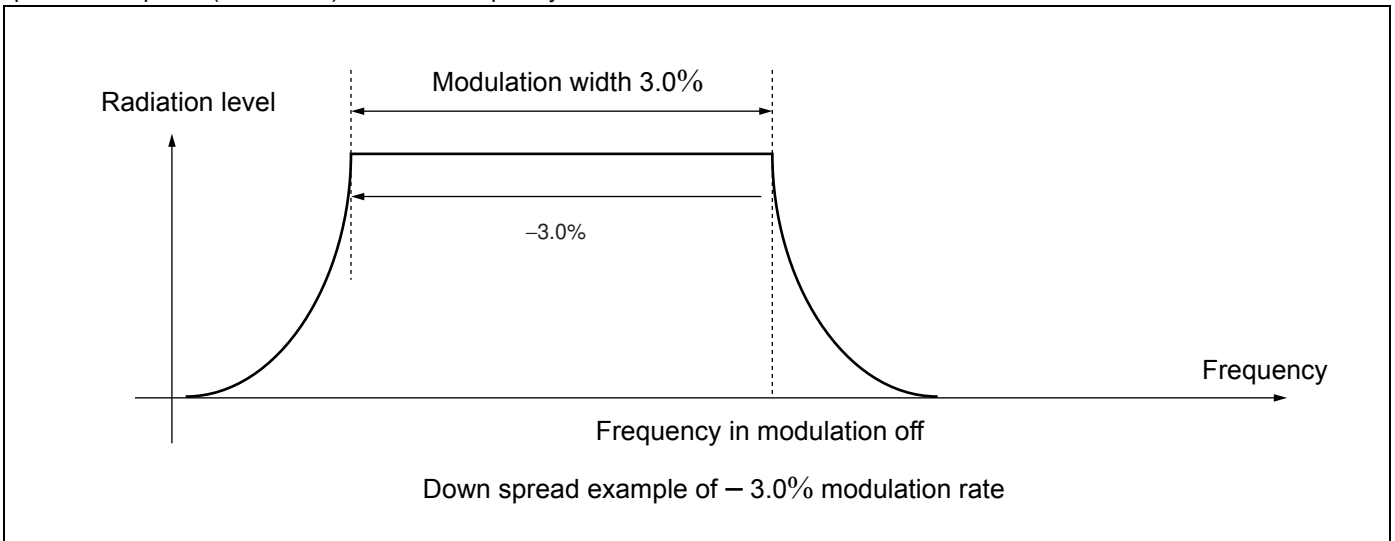

8. Absolute Maximum Ratings

Parameter	Symbol	Rating		Unit
		Min	Max	
Power supply voltage*	V_{DD}	- 0.5	+ 4.0	V
Input voltage*	V_I	$V_{SS} - 0.5$	$V_{DD} + 0.5$	V
Output voltage*	V_O	$V_{SS} - 0.5$	$V_{DD} + 0.5$	V
Storage temperature	T_{ST}	- 55	+ 125	°C
Operation junction temperature	T_J	- 40	+ 125	°C
Output current	I_O	- 14	+ 14	mA
Overshoot	V_{IOVER}	—	$V_{DD} + 1.0$ ($t_{OVER} \leq 50$ ns)	V
Undershoot	V_{IUNDER}	$V_{SS} - 1.0$ ($t_{UNDER} \leq 50$ ns)	—	V

* : The parameter is based on $V_{SS} = 0.0$ V.

WARNING: Semiconductor devices can be permanently damaged by application of stress (voltage, current, temperature, etc.) in excess of absolute maximum ratings. Do not exceed these ratings.

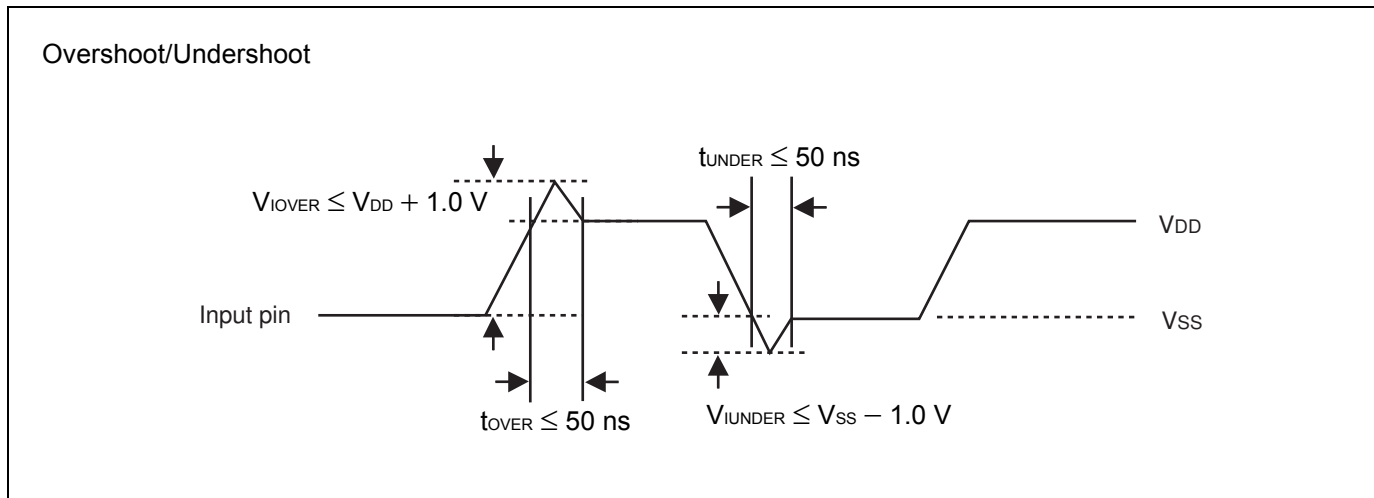

9. Recommended Operating Conditions

(V_{SS} = 0.0 V)

Parameter	Symbol	Pin	Conditions	Value			Unit
				Min	Typ	Max	
Power supply voltage	V _{DD}	V _{DD}	—	3.0	3.3	3.6	V
“H” level input voltage	V _{IH}	XIN, SEL0, SEL1, ENS	—	V _{DD} × 0.8	—	V _{DD} + 0.3	V
“L” level input voltage	V _{IL}		—	V _{SS}	—	V _{DD} × 0.2	V
Input clock duty cycle	t _{DCI}	XIN	8.3 MHz to 33.4 MHz	40	50	60	%
Operating temperature	T _a	—	—	- 40	—	+ 85	°C

WARNING: The recommended operating conditions are required in order to ensure the normal operation of the semiconductor device. All of the device's electrical characteristics are warranted when the device is operated within these ranges.

Always use semiconductor devices within their recommended operating condition ranges. Operation outside these ranges may adversely affect reliability and could result in device failure. No warranty is made with respect to uses, operating conditions, or combinations not represented on the data sheet. Users considering application outside the listed conditions are advised to contact their representatives beforehand.

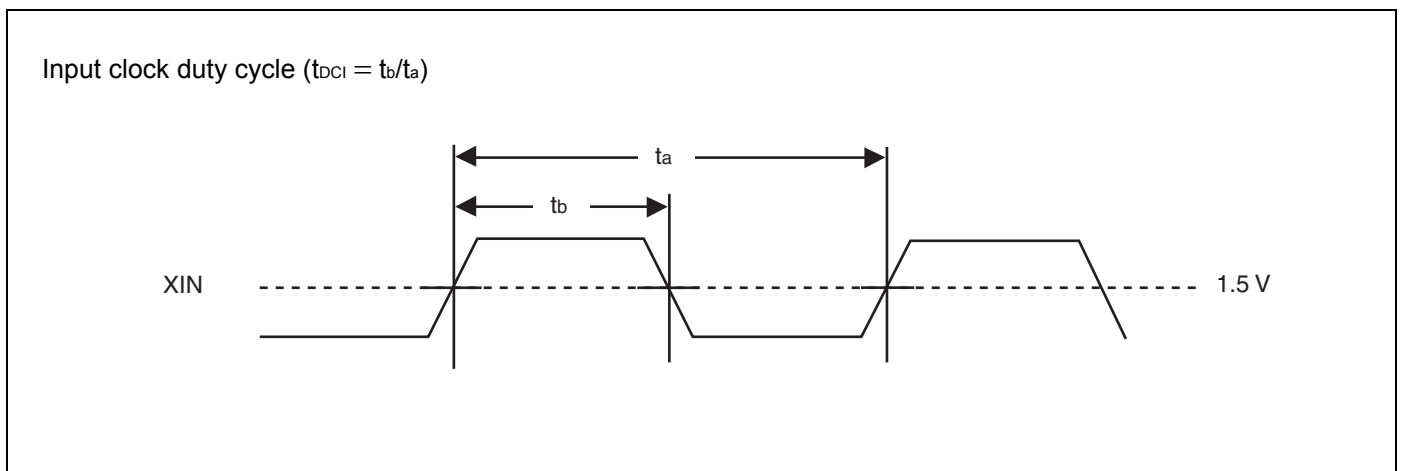

10. Electrical Characteristics

■ DC Characteristics

($T_a = -40\text{ }^{\circ}\text{C}$ to $+85\text{ }^{\circ}\text{C}$, $V_{DD} = 3.3\text{ V} \pm 0.3\text{ V}$, $V_{SS} = 0.0\text{ V}$)

Parameter	Symbol	Pin	Conditions	Value			Unit
				Min	Typ	Max	
Power supply current	I_{CC}	V_{DD}	No load capacitance at output 24 MHz MB88151A-100	—	5.0	7.0	mA
			At power down MB88151A-101	—	10	—	μA
Output voltage	V_{OH}	CKOUT	“H” level output, $I_{OH} = -4\text{ mA}$	$V_{DD} - 0.5$	—	V_{DD}	V
	V_{OL}		“L” level output, $I_{OL} = 4\text{ mA}$	V_{SS}	—	0.4	V
Output impedance	Z_o	CKOUT	8.3 MHz to 133.6 MHz	—	45	—	Ω
Input capacitance	C_{IN}	XIN, SELO, SEL1, ENS	$T_a = +25\text{ }^{\circ}\text{C}$, $V_{DD} = V_i = 0.0\text{ V}$, $f = 1\text{ MHz}$	—	—	16	pF
Load capacitance	C_L	CKOUT	8.3 MHz to 66.8 MHz	—	—	15	pF
			66.8 MHz to 100 MHz	—	—	10	
			100 MHz to 133.6 MHz	—	—	7	
Input pull-up resistance	R_{PUE}	ENS	$V_{IL} = 0.0\text{ V}$	25	50	200	$\text{k}\Omega$
	R_{PUP}	XPD	$V_{IL} = 0.0\text{ V}$	500	800	1200	

■ AC Characteristics

 (Ta = -40 °C to +85 °C, V_{DD} = 3.3 V ± 0.3 V, V_{SS} = 0.0 V)

Parameter	Symbol	Pin	Conditions	Value			Unit
				Min	Typ	Max	
Oscillation frequency	f _x	XIN, XOUT	Fundamental oscillation	8.3	—	33.4	MHz
Input frequency	f _{in}	XIN	External clock input (multiply-by-1, 2, 4, divided by 2)	16.6	—	33.4	MHz
			External clock input (multiply-by-8)	8.3	—	16.7	
Output frequency	f _{OUT}	CKOUT	MB88151A-100/101 (Multiply by 1)	16.6	—	33.4	MHz
			MB88151A-200/201 (Multiply by 2)	33.2	—	66.8	
			MB88151A-400/401 (Multiply by 4)	66.4	—	133.6	
			MB88151A-500/501 (2-frequency division)	8.3	—	16.7	
			MB88151A-800/801 (multiply-by-8)	66.4	—	133.6	
Output slew rate	SR	CKOUT	0.4 V to 2.4 V Load capacitance 15 pF	0.4	—	4.0	V/ns
Output clock duty cycle	t _{DCC}	CKOUT	1.5 V	40	—	60	%
Modulation period (Number of input clocks per modulation)	f _{MOD} (n _{MOD})	CKOUT	MB88151A-100/101, MB88151A-200/201, MB88151A-400/401, MB88151A-500/501	f _{in} /2200 (2200)	f _{in} /1900 (1900)	f _{in} /1600 (1600)	kHz (clks)
			MB88151A-800/801	f _{in} /880 (880)	f _{in} /760 (760)	f _{in} /640 (640)	kHz (clks)
Lock-up time	t _{LK}	CKOUT	8.3 MHz to 80 MHz	—	2	5	ms
			80 MHz to 133.6 MHz	—	3	8	
Cycle-cycle jitter	t _{JC}	CKOUT	MB88151A-100/101, MB88151A-200/201 No load capacitance, Ta = +25 °C, V _{DD} = 3.3 V	—	—	100	ps-rms
			MB88151A-400/401, MB88151A-800/801 No load capacitance, Ta = +25 °C, V _{DD} = 3.3 V	—	—	150	
			MB88151A-500/501 No load capacitance, Ta = +25 °C, V _{DD} = 3.3 V	—	—	200	

Note : The modulation clock stabilization wait time is required after the power is turned on, the IC recovers from power saving, or after FREQ (frequency range) or ENS (modulation ON/OFF) setting is changed. For the modulation clock stabilization wait time, assign the maximum value for lock-up time.

<Definition of modulation frequency and number of input clocks per modulation>

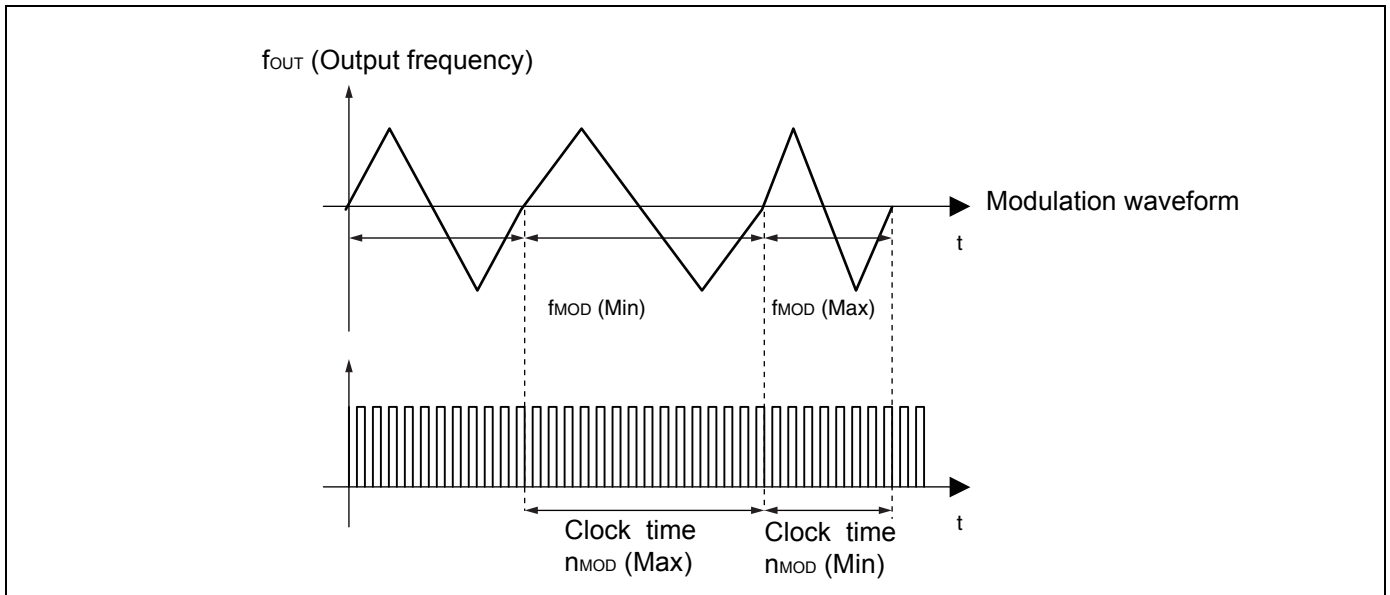

MB88151A contains the modulation period to realize the efficient EMI reduction.

The modulation period f_{MOD} depends on the input frequency and changes between $f_{MOD} (Min)$ and $f_{MOD} (Max)$.

Furthermore, the average value of f_{MOD} equals the typical value of the electrical characteristics.

11. Output Clock Duty Cycle ($t_{DCC} = t_b/t_a$)

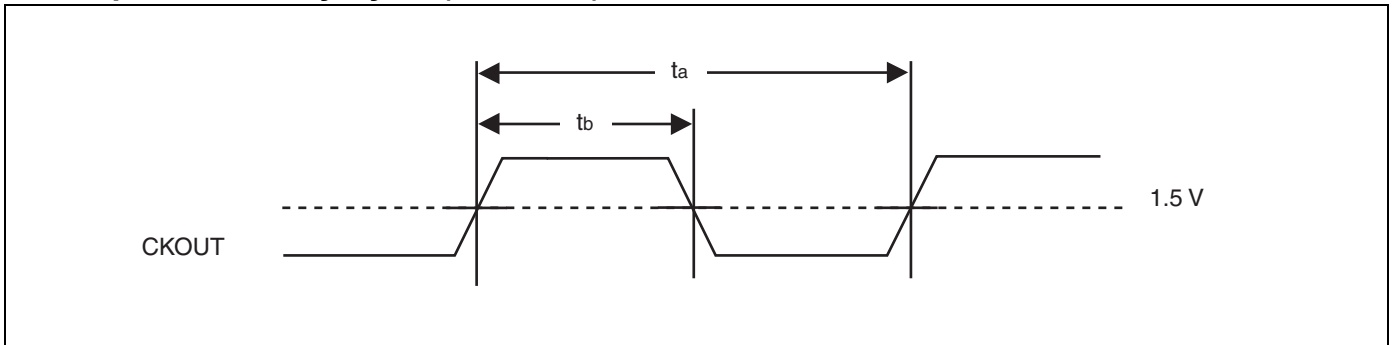

12. Input Frequency ($f_{in} = 1/t_{in}$)

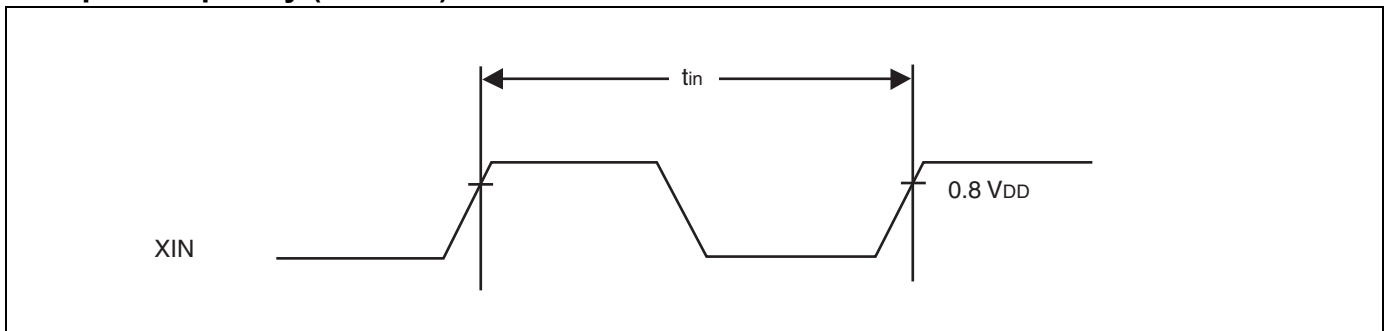

13. Output Slew Rate (SR)

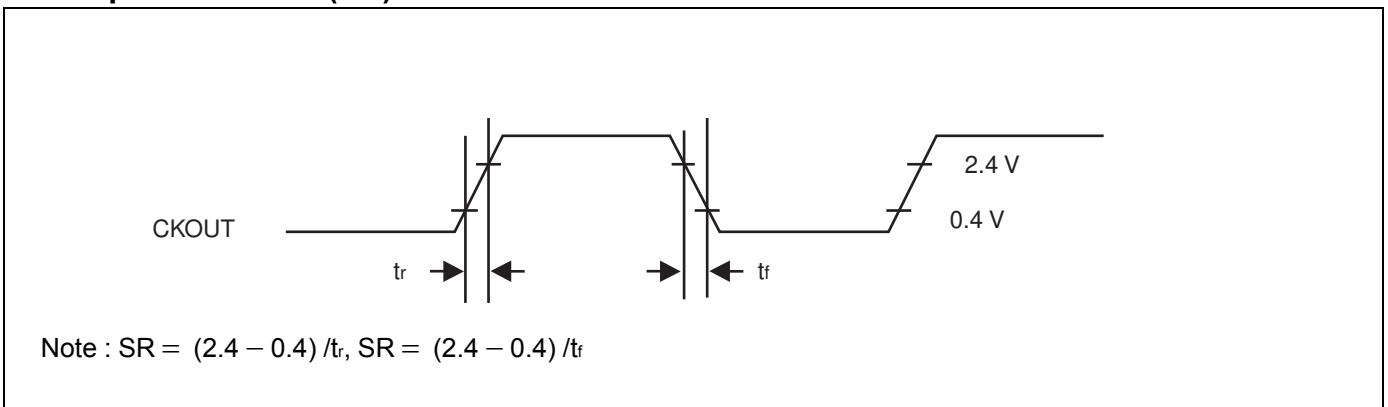

14. Cycle-cycle Jitter ($t_{JC} = | t_n - t_{n+1} |$)



Note : Cycle-cycle jitter is defined the difference between a certain cycle and immediately after (or, immediately before) .

15. Modulation Waveform

- $\pm 1.5\%$ modulation rate, Example of center spread

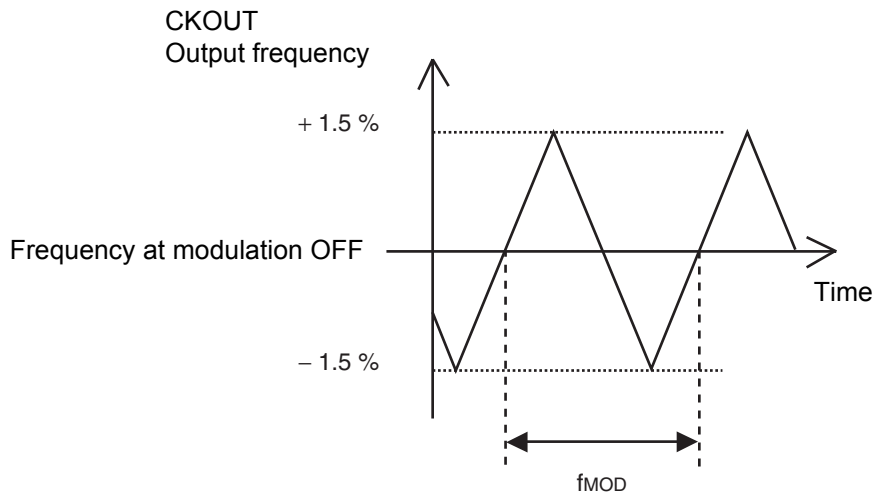

- -1.0% modulation rate, Example of down spread

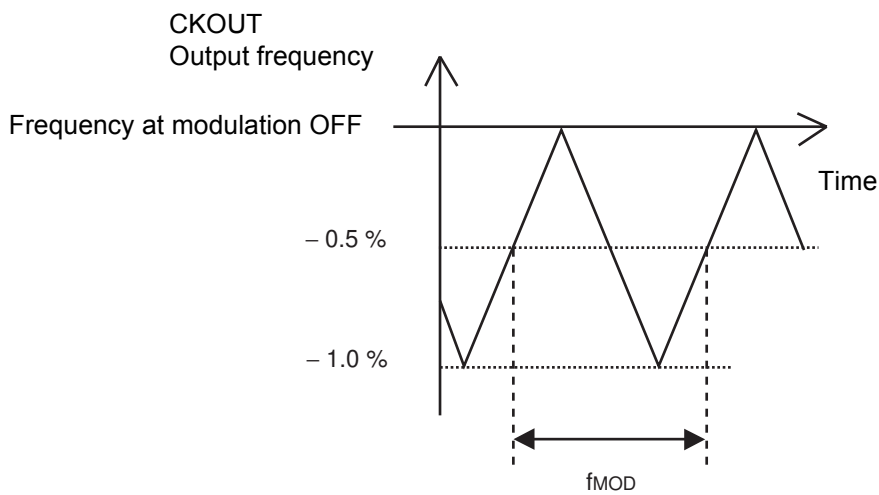

16. Lock-up Time

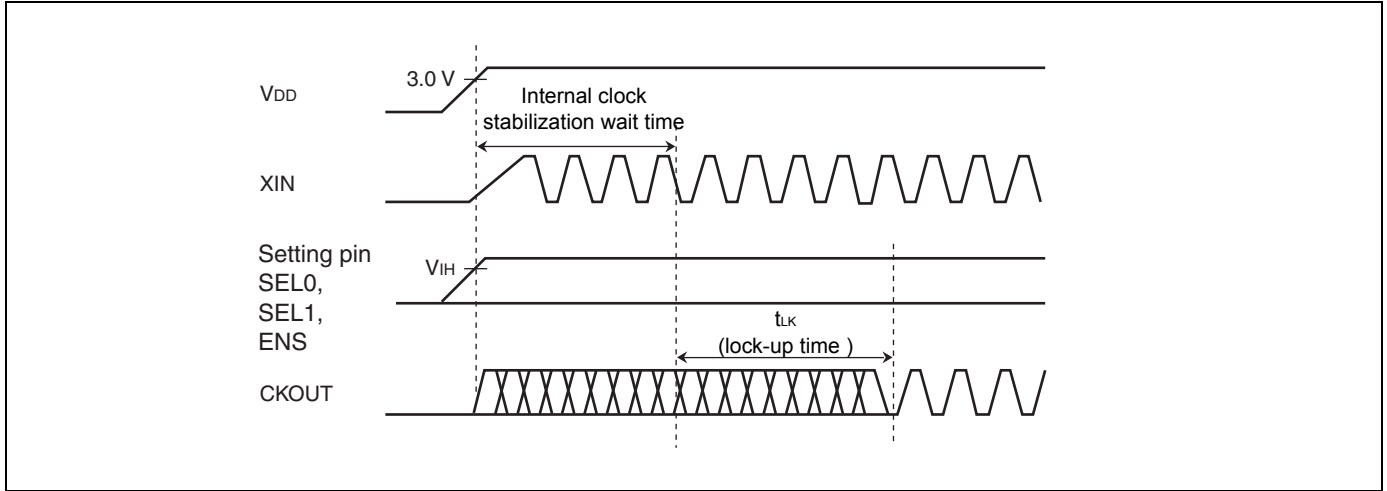

If the setting pin is fixed at the “H” or “L” level, the maximum time after the power is turned on until the set clock signal is output from CKOUT pin is (the stabilization wait time of input clock to XIN pin) + (the lock-up time “t_{LK}”). For the input clock stabilization time, check the characteristics of the resonator or oscillator used.

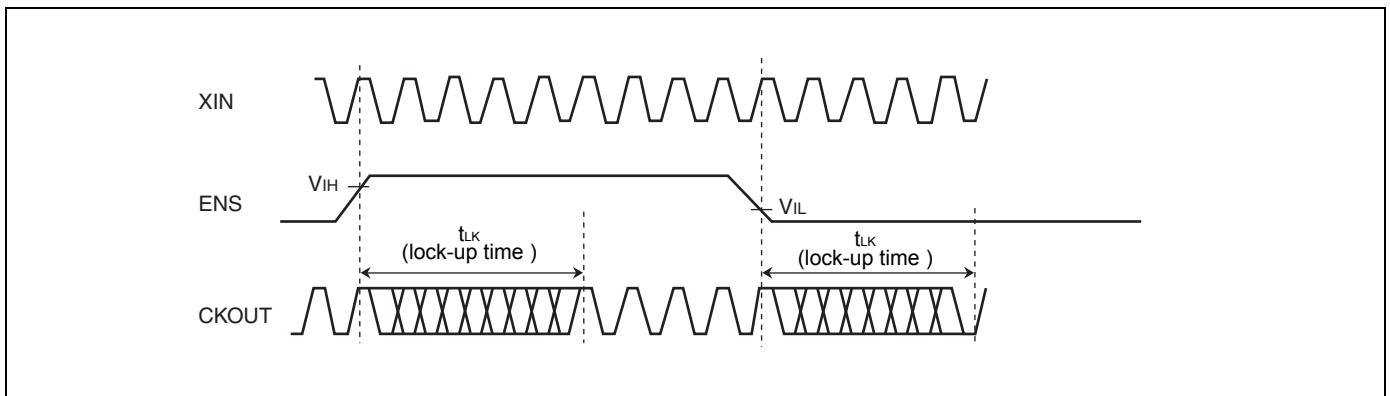

For modulation enable control using the ENS pin during normal operation, the set clock signal is output from CKOUT pin at most the lock-up time (t_{LK}) after the level at the ENS pin is determined.

Note : When the pin setting is changed, the CKOUT pin output clock stabilization time is required. Until the output clock signal becomes stable, the output frequency, output clock duty cycle, modulation period, and cycle-cycle jitter cannot be guaranteed. It is therefore advisable to perform processing such as cancelling a reset of the device at the succeeding stage after the lock-up time.

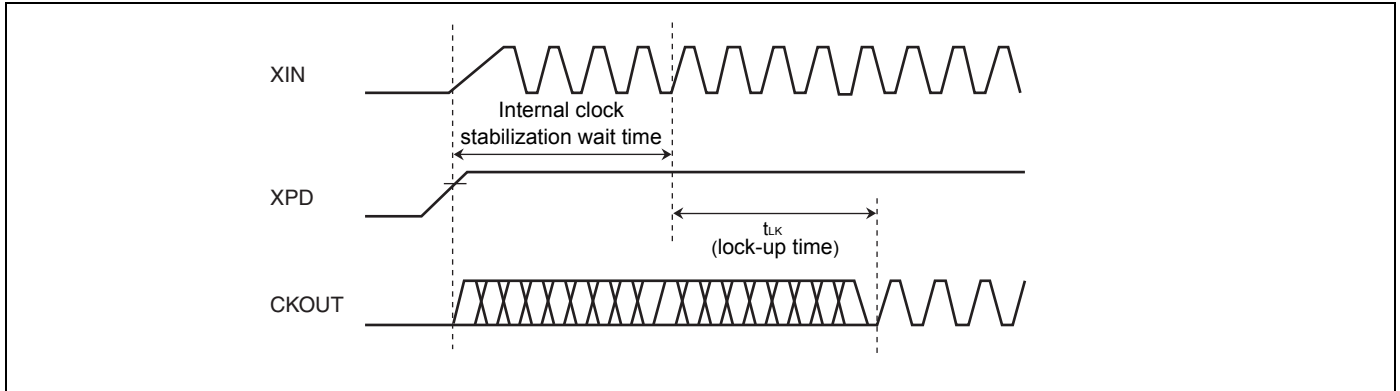

When the power down is controlled by XPD pin, the desired clock is obtained after the pin is set to H level until the maximum lock-up time t_{LK} is elapsed.

17. Oscillation Circuit

The figure below shows the connection example about general resonator. The oscillation circuit has the built-in resistance (R_f). The value of capacity (C_1 and C_2) is required adjusting to the most suitable value of individual resonator. The most suitable value is different by individual resonator. Please refer to the resonator manufacturer which you use for the most suitable value.

Input the clock to XIN pin, and do not connect anything with XOUT pin if you use the external clock (you do not use the resonator).

■ When using the resonator

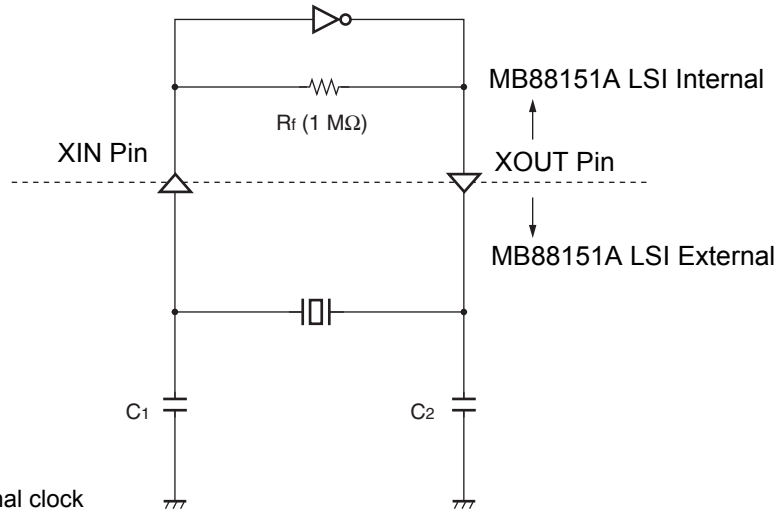

■ When using an external clock

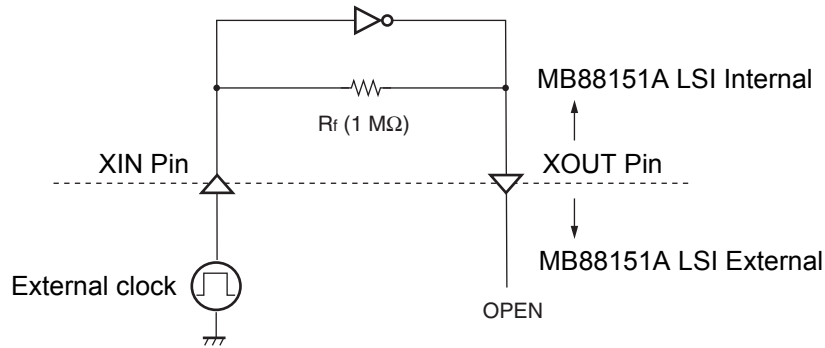

Note : Note that a jitter characteristic of an input clock may cause an affect a cycle-cycle jitter characteristic.

18. Interconnection Circuit Example

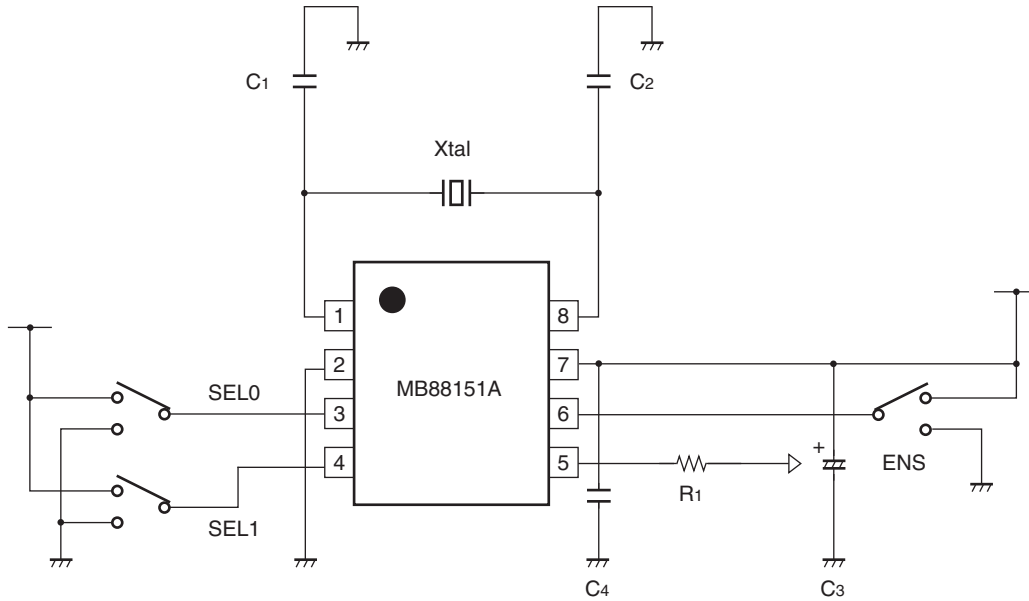

- C₁, C₂ : Oscillation stabilization capacitance (refer to "Oscillation Circuit".)
- C₃ : Capacitor of 10 μF or higher
- C₄ : Capacitor about 0.01 μF (connect a capacitor of good high frequency property (ex. laminated ceramic capacitor) to close to this device.)
- R₁ : Impedance matching resistor for board pattern

19. Spectrum Example Characteristics

The condition of the examples of the characteristic is shown as follows : Input frequency = 20 MHz (Output frequency = 20 MHz : Using MB88151A-100 (Multiply-by-1)), Power - supply voltage = 3.3 V, None load capacity, Modulation rate = $\pm 1.5\%$ (center spread). Spectrum analyzer HP4396B is connected with CKOUT. The result of the measurement with RBW = 1 kHz (ATT use for - 6dB).

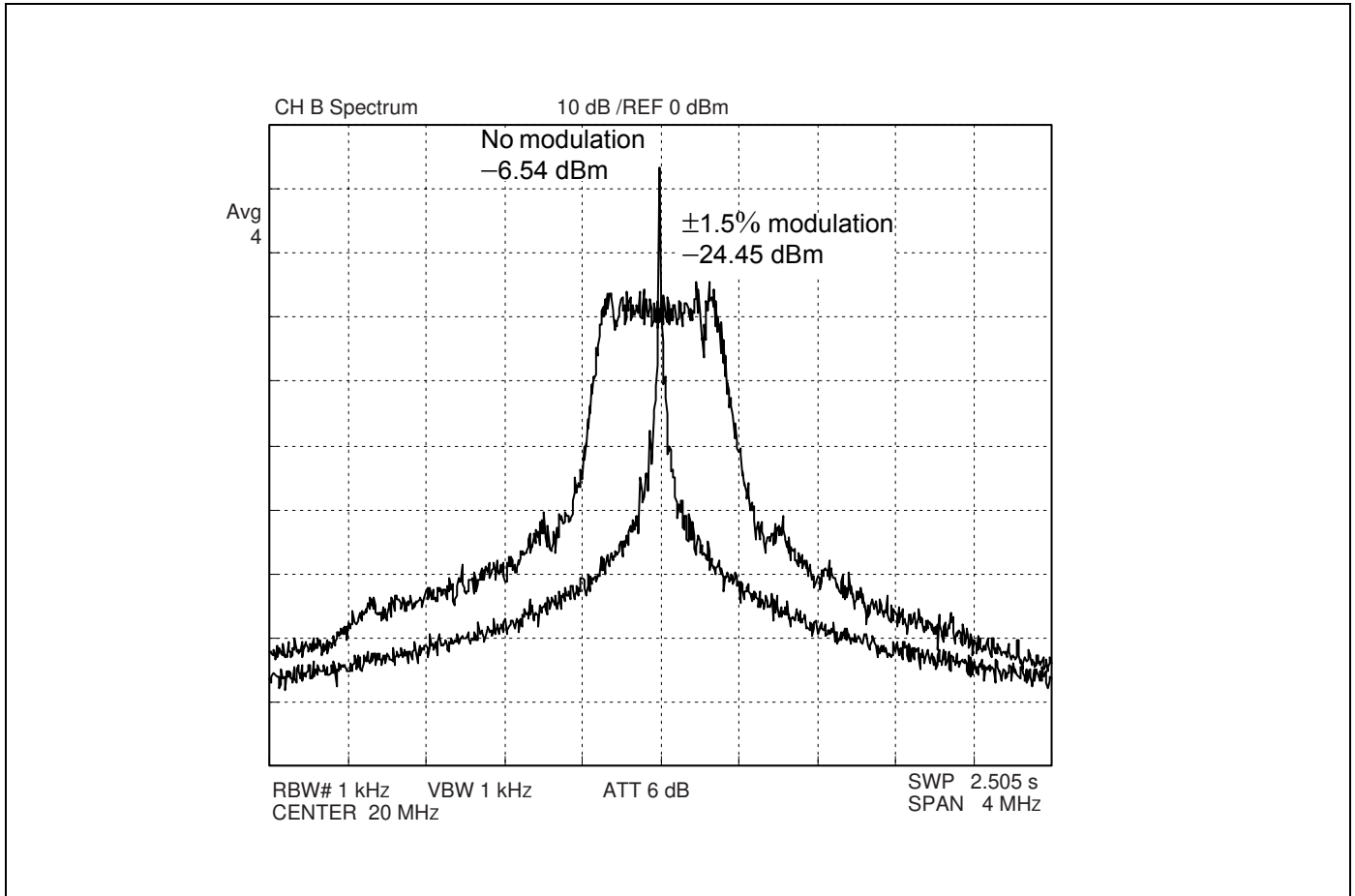

20. Ordering Information

Part number	Input frequency range	Multiplier ratio	Output frequency range	Package	Remarks		
MB88151APNF-G-100-JNE1 MB88151APNF-G-101-JNE1	16.6 MHz to 33.4 MHz	Multiply-by-1	16.6 MHz to 33.4 MHz	8-pin plastic SOP (FPT-8P-M02)			
MB88151APNF-G-200-JNE1 MB88151APNF-G-201-JNE1		Multiply-by-2	33.2 MHz to 66.8 MHz				
MB88151APNF-G-400-JNE1 MB88151APNF-G-401-JNE1		Multiply-by-4	66.4 MHz to 133.6 MHz				
MB88151APNF-G-500-JNE1 MB88151APNF-G-501-JNE1		Multiply-by-1/2	8.3 MHz to 16.7 MHz				
MB88151APNF-G-800-JNE1 MB88151APNF-G-801-JNE1	8.3 MHz to 16.7 MHz	Multiply-by-8	66.4 MHz to 133.6 MHz				
MB88151APNF-G-100-JNEFE1 MB88151APNF-G-101-JNEFE1	16.6 MHz to 33.4 MHz	Multiply-by-1	16.6 MHz to 33.4 MHz		8-pin plastic SOP (FPT-8P-M02)	Emboss taping (EF type)	
MB88151APNF-G-200-JNEFE1 MB88151APNF-G-201-JNEFE1		Multiply-by-2	33.2 MHz to 66.8 MHz				
MB88151APNF-G-400-JNEFE1 MB88151APNF-G-401-JNEFE1		Multiply-by-4	66.4 MHz to 133.6 MHz				
MB88151APNF-G-500-JNEFE1 MB88151APNF-G-501-JNEFE1		Multiply-by-1/2	8.3 MHz to 16.7 MHz				
MB88151APNF-G-800-JNEFE1 MB88151APNF-G-801-JNEFE1	8.3 MHz to 16.7 MHz	Multiply-by-8	66.4 MHz to 133.6 MHz				
MB88151APNF-G-100-JNERE1 MB88151APNF-G-101-JNERE1	16.6 MHz to 33.4 MHz	Multiply-by-1	16.6 MHz to 33.4 MHz			8-pin plastic SOP (FPT-8P-M02)	
MB88151APNF-G-200-JNERE1 MB88151APNF-G-201-JNERE1		Multiply-by-2	33.2 MHz to 66.8 MHz				
MB88151APNF-G-400-JNERE1 MB88151APNF-G-401-JNERE1		Multiply-by-4	66.4 MHz to 133.6 MHz				
MB88151APNF-G-500-JNERE1 MB88151APNF-G-501-JNERE1		Multiply-by-1/2	8.3 MHz to 16.7 MHz				
MB88151APNF-G-800-JNERE1 MB88151APNF-G-801-JNERE1	8.3 MHz to 16.7 MHz	Multiply-by-8	66.4 MHz to 133.6 MHz	Emboss taping (ER type)			

21. Package Dimension

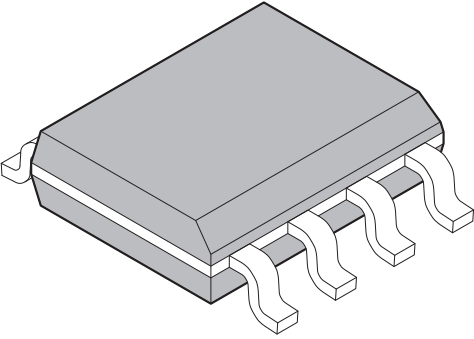
<p>8-pin plastic SOP</p>  <p>(FPT-8P-M02)</p>	Lead pitch	1.27 mm
	Package width package length	3.9 5.05 mm
	Lead shape	Gullwing
	Sealing method	Plastic mold
	Mounting height	1.75 mm MAX
	Weight	0.06 g

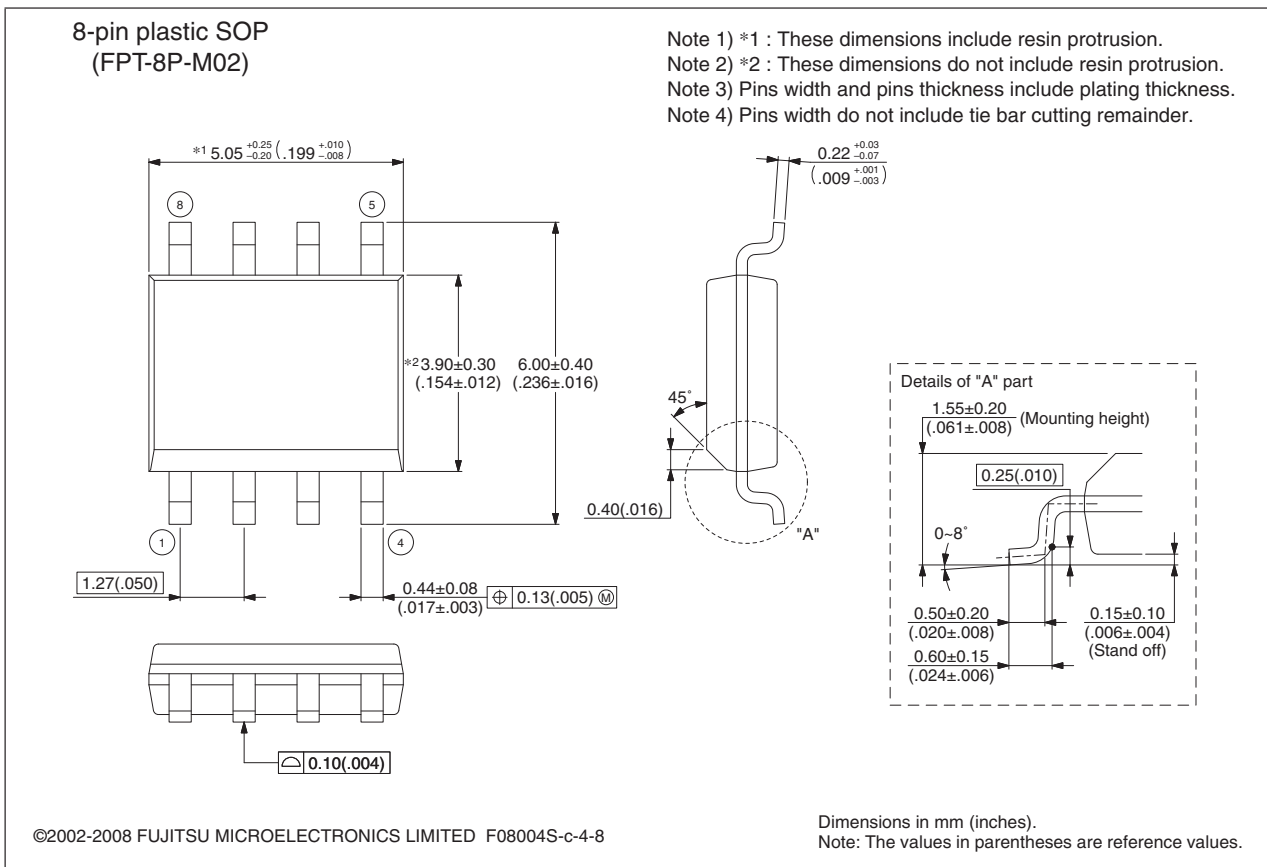

Document History

Spansion Publication Number: DS04-29127-3E

Document Title: MB88151A Spread Spectrum Clock Generator Document Number: 002-08311				
Revision	ECN	Orig. of Change	Submission Date	Description of Change
**	-	TAOA	06/29/2009	Initial Release
*A	5569547	TAOA	12/30/2016	Updated to Cypress Template