



Chipsmall Limited consists of a professional team with an average of over 10 year of expertise in the distribution of electronic components. Based in Hongkong, we have already established firm and mutual-benefit business relationships with customers from,Europe,America and south Asia,supplying obsolete and hard-to-find components to meet their specific needs.

With the principle of “Quality Parts,Customers Priority,Honest Operation,and Considerate Service”,our business mainly focus on the distribution of electronic components. Line cards we deal with include Microchip,ALPS,ROHM,Xilinx,Pulse,ON,Everlight and Freescale. Main products comprise IC,Modules,Potentiometer,IC Socket,Relay,Connector.Our parts cover such applications as commercial,industrial, and automotives areas.

We are looking forward to setting up business relationship with you and hope to provide you with the best service and solution. Let us make a better world for our industry!



## Contact us

Tel: +86-755-8981 8866 Fax: +86-755-8427 6832

Email & Skype: info@chipsmall.com Web: www.chipsmall.com

Address: A1208, Overseas Decoration Building, #122 Zhenhua RD., Futian, Shenzhen, China



# F<sup>2</sup>MC-16FX 16-bit Proprietary Microcontroller

MB96310 series is based on Cypress advanced 16FX architecture (16-bit with instruction pipeline for RISC-like performance). The CPU uses the same instruction set as the established 16LX series - thus allowing for easy migration of 16LX Software to the new 16FX products. 16FX improvements compared to the previous generation include significantly improved performance - even at the same operation frequency, reduced power consumption and faster start-up time.

For highest processing speed at optimized power consumption an internal PLL can be selected to supply the CPU with up to 56MHz operation frequency from an external 4MHz resonator. The result is a minimum instruction cycle time of 17.8ns going together with excellent EMI behavior. An on-chip clock modulation circuit significantly reduces emission peaks in the frequency spectrum. The emitted power is minimized by the on-chip voltage regulator that reduces the internal CPU voltage. A flexible clock tree allows to select suitable operation frequencies for peripheral resources independent of the CPU speed.

## Features

### Technology

- 0.18 $\mu$ m CMOS

### CPU

- F<sup>2</sup>MC-16FX CPU
- Up to 56 MHz internal, 17.8 ns instruction cycle time
- Optimized instruction set for controller applications (bit, byte, word and long-word data types; 23 different addressing modes; barrel shift; variety of pointers)
- 8-byte instruction execution queue
- Signed multiply (16-bit  $\times$  16-bit) and divide (32-bit/16-bit) instructions available

### System clock

- On-chip PLL clock multiplier (x1 - x25, x1 when PLL stop)
- 3 MHz - 16 MHz external crystal oscillator clock (maximum frequency when using ceramic resonator depends on Q-factor).
- Up to 56 MHz external clock
- 32-100 kHz subsystem quartz clock
- 100kHz/2MHz internal RC clock for quick and safe startup, oscillator stop detection, watchdog
- Clock source selectable from main- and subclock oscillator (part number suffix "W") and on-chip RC oscillator, independently for CPU and 2 clock domains of peripherals.
- Low Power Consumption - 13 operating modes: (different Run, Sleep, Timer modes, Stop mode)
- Clock modulator

### On-chip voltage regulator

- Internal voltage regulator supports reduced internal MCU voltage, offering low EMI and low power consumption figures

### Low voltage reset

- Reset is generated when supply voltage is below minimum.

### Code Security

- Protects ROM content from unintended read-out

### Memory Patch Function

- Replaces ROM content
- Can also be used to implement embedded debug support

### DMA

- Automatic transfer function independent of CPU, can be assigned freely to resources

### Interrupts

- Fast Interrupt processing
- 8 programmable priority levels
- Non-Maskable Interrupt (NMI)

### Timers

- Three independent clock timers (23-bit RC clock timer, 23-bit Main clock timer, 17-bit Sub clock timer)
- Watchdog Timer

### CAN

- Supports CAN protocol version 2.0 part A and B
- ISO16845 certified
- Bit rates up to 1 Mbit/s
- 32 message objects
- Each message object has its own identifier mask
- Programmable FIFO mode (concatenation of message objects)
- Maskable interrupt
- Disabled Automatic Retransmission mode for Time Triggered CAN applications
- Programmable loop-back mode for self-test operation



## USART

- Full duplex USARTs (SCI/LIN)
- Wide range of baud rate settings using a dedicated reload timer
- Special synchronous options for adapting to different synchronous serial protocols
- LIN functionality working either as master or slave LIN device

## A/D converter

- SAR-type
- 10-bit resolution
- Signals interrupt on conversion end, single conversion mode, continuous conversion mode, stop conversion mode, activation by software, external trigger or reload timer

## Reload Timers

- 16-bit wide
- Prescaler with  $1/2^1$ ,  $1/2^2$ ,  $1/2^3$ ,  $1/2^4$ ,  $1/2^5$ ,  $1/2^6$  of peripheral clock frequency
- Event count function

## Free Running Timers

- Signals an interrupt on overflow, supports timer clear upon match with Output Compare (0, 4), Prescaler with 1,  $1/2^1$ ,  $1/2^2$ ,  $1/2^3$ ,  $1/2^4$ ,  $1/2^5$ ,  $1/2^6$ ,  $1/2^7$ ,  $1/2^8$  of peripheral clock frequency

## Input Capture Units

- 16-bit wide
- Signals an interrupt upon external event
- Rising edge, falling edge or rising & falling edge sensitive

## Output Compare Units

- 16-bit wide
- Signals an interrupt when a match with 16-bit I/O Timer occurs
- A pair of compare registers can be used to generate an output signal.

## Programmable Pulse Generator

- 16-bit down counter, cycle and duty setting registers
- Interrupt at trigger, counter borrow and/or duty match
- PWM operation and one-shot operation
- Internal prescaler allows 1, 1/4, 1/16, 1/64 of peripheral clock as counter clock and Reload timer underflow as clock input
- Can be triggered by software or reload timer

## Real Time Clock

- Can be clocked either from sub oscillator (devices with part number suffix "W"), main oscillator or from the RC oscillator
- Facility to correct oscillation deviation of Sub clock or RC oscillator clock (clock calibration)
- Read/write accessible second/minute/hour registers
- Can signal interrupts every half second/second/minute/hour/day
- Internal clock divider and prescaler provide exact 1s clock

## External Interrupts

- Edge sensitive or level sensitive
- Interrupt mask and pending bit per channel
- Each available CAN channel RX has an external interrupt for wake-up
- Selected USART channels SIN have an external interrupt for wake-up

## Non Maskable Interrupt

- Disabled after reset
- Once enabled, can not be disabled other than by reset.
- Level high or level low sensitive
- Pin shared with external interrupt 0.

## I/O Ports

- Virtually all external pins can be used as general purpose I/O
- All push-pull outputs
- Bit-wise programmable as input/output or peripheral signal
- Bit-wise programmable input enable
- Bit-wise programmable input levels: Automotive / CMOS-Schmitt trigger / TTL
- Bit-wise programmable pull-up resistor
- Bit-wise programmable output driving strength for EMI optimization

## Packages

- 48-pin plastic LQFP M26

## **Flash Memory**

- Supports automatic programming, Embedded Algorithm
- Write/Erase/Erase-Suspend/Resume commands
- A flag indicating completion of the algorithm
- Number of erase cycles: 10,000 times
- Data retention time: 20 years
- Erase can be performed on each sector individually
- Sector protection
- Flash Security feature to protect the content of the Flash
- Low voltage detection during Flash erase

**Contents**

<b>Product Lineup</b> .....	<b>5</b>	Pin handling when not using the A/D converter .....	43
<b>Block Diagram</b> .....	<b>6</b>	Notes on Power-on .....	43
<b>Pin Assignments</b> .....	<b>7</b>	Stabilization of power supply voltage .....	44
<b>Pin Function Description</b> .....	<b>8</b>	Serial communication .....	44
<b>Pin Circuit Type</b> .....	<b>10</b>	<b>Electrical Characteristics</b> .....	<b>45</b>
<b>I/O Circuit Type</b> .....	<b>11</b>	Absolute Maximum Ratings .....	45
<b>Memory Map</b> .....	<b>13</b>	Recommended Operating Conditions .....	47
<b>RAMSTART Addresses</b> .....	<b>14</b>	DC characteristics .....	48
<b>User ROM Memory Map for Flash Devices</b> .....	<b>15</b>	AC Characteristics .....	55
<b>Serial Programming Communication Interface</b> .....	<b>16</b>	Analog Digital Converter .....	63
<b>I/O Map</b> .....	<b>17</b>	Low Voltage Detector characteristics .....	67
<b>Interrupt Vector Table</b> .....	<b>39</b>	FLASH memory program/erase characteristics .....	69
<b>Handling Devices</b> .....	<b>42</b>	<b>Example Characteristics</b> .....	<b>70</b>
Latch-up prevention .....	42	Temperature dependency of	
Unused pins handling .....	42	power supply currents .....	70
External clock usage .....	42	Frequency dependency of	
Unused sub clock signal .....	43	power supply currents in PLL Run mode .....	75
Notes on PLL clock mode operation .....	43	<b>Package Dimension MB96(F)31x LQFP48</b> .....	<b>76</b>
Power supply pins (VCC/VSS) .....	43	<b>Ordering Information</b> .....	<b>77</b>
Crystal oscillator and ceramic resonator circuit .....	43	<b>Revision History</b> .....	<b>78</b>
Turn on sequence of power supply to		<b>Major Changes</b> .....	<b>79</b>
A/D converter and analog inputs .....	43	<b>Document History</b> .....	<b>80</b>

## 1. Product Lineup

Features		MB96V300C	MB96(F)31x
Product type		Evaluation sample	Flash product: MB96F31x Mask ROM product: MB9631x
Product options			
YS		NA	Low voltage reset persistently on / Single clock devices
RS			Low voltage reset can be disabled / Single clock devices
YW			Low voltage reset persistently on / Dual clock devices
RW			Low voltage reset can be disabled / Dual clock devices
AS			No CAN / Low voltage reset can be disabled / Single clock devices
AW			No CAN / Low voltage reset can be disabled / Dual clock devices
Flash/ROM	RAM		
96KB	8KB	ROM/Flash memory emulation by external RAM, 92KB internal RAM	MB96F313Y, MB96F313R, MB96F313A
160KB	8KB		MB96F315Y, MB96F315R, MB96F315A
Package		BGA416	FPT-48P-M26
DMA		16 channels	4 channels
USART		10 channels	3 channels
A/D Converter		40 channels	12 channels
A/D Converter Reference Voltage switch		yes	No
16-bit Reload Timer		6 channels + 1 channel (for PPG)	4 channels + 1 channel (for PPG)
16-bit Free-Running Timer		4 channels	4 channels (without external clock input pin)
16-bit Output Compare		12 channels	2 channels
16-bit Input Capture		12 channels	4 channels (plus 3 channels for LIN USART)
16-bit Programmable Pulse Generator		20 channels	14 channels
CAN Interface		5 channels	1 channel
External Interrupts		16 channels	11 channels
Non-Maskable Interrupt			1 channel
Real Time Clock			1
I/O Ports		136	34 for part number with suffix "W", 36 for part number with suffix "S"
Clock output function			2 channels
Low voltage reset			Yes
On-chip RC-oscillator			Yes

## 2. Block Diagram

Block diagram of MB96(F)31x

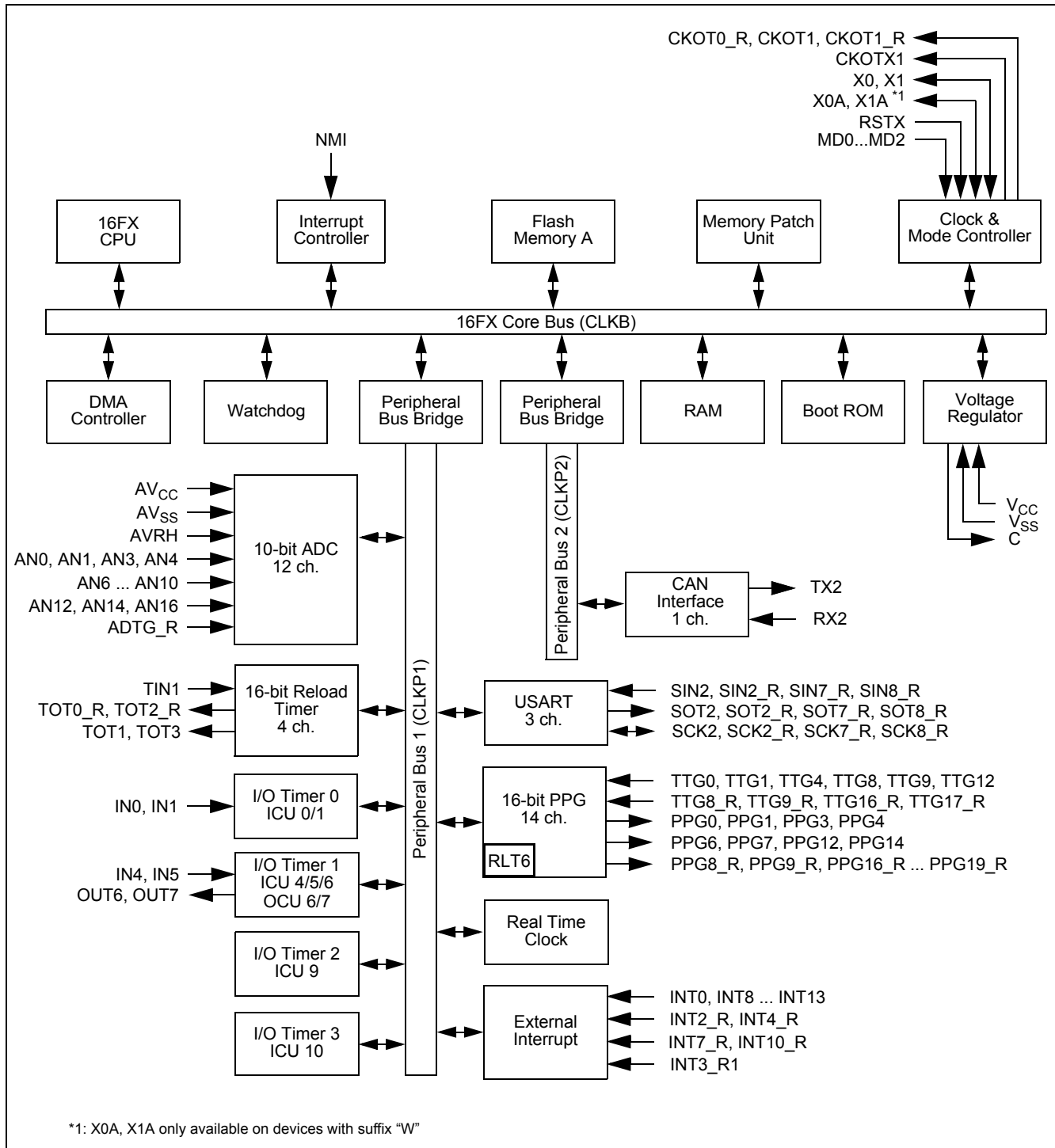

### 3. Pin Assignments

Pin assignment of MB96(F)31x

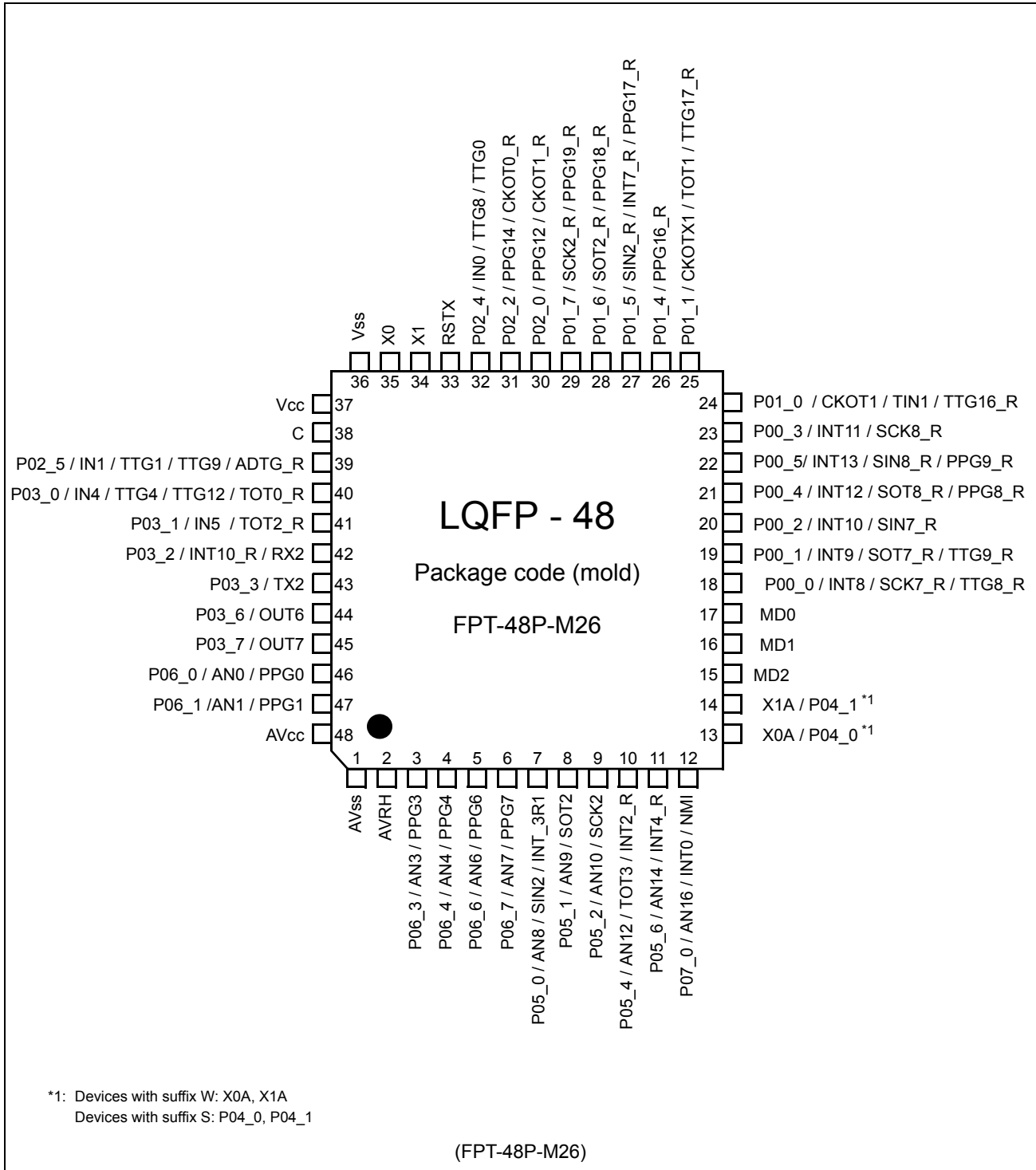



## 4. Pin Function Description

### Pin Function description (1 of 2)

Pin name	Feature	Description
ADTG_R	ADC	Relocated A/D converter trigger input
ANn	ADC	A/D converter channel n input
AV <sub>CC</sub>	Supply	Analog circuits power supply
AVRH	ADC	A/D converter high reference voltage input
AV <sub>SS</sub>	Supply	Analog circuits power supply
C	Voltage regulator	Internally regulated power supply stabilization capacitor pin
CKOTn	Clock output function	Clock Output function n output
CKOTn_R	Clock output function	Relocated Clock Output function n output
CKOTXn	Clock output function	Clock Output function n inverted output
INn	ICU	Input Capture Unit n input
INTn	External Interrupt	External Interrupt n input
INTn_R	External Interrupt	Relocated External Interrupt n input
MDn	Core	Input pins for specifying the operating mode.
NMI	External Interrupt	Non-Maskable Interrupt input
OUTn	OCU	Output Compare Unit n waveform output
Pxx_n	GPIO	General purpose IO
PPGn	PPG	Programmable Pulse Generator n output
PPGn_R	PPG	Relocated Programmable Pulse Generator n output
RSTX	Core	Reset input
RXn	CAN	CAN interface n RX input
SCKn	USART	USART n serial clock input/output
SCKn_R	USART	Relocated USART n serial clock input/output
SINn	USART	USART n serial data input
SINn_R	USART	Relocated USART n serial data input
SOTn	USART	USART n serial data output
SOTn_R	USART	Relocated USART n serial data output
TINn	Reload Timer	Reload Timer n event input
TINn_R	Reload Timer	Relocated Reload Timer n event input
TOTn	Reload Timer	Reload Timer n output
TOTn_R	Reload Timer	Relocated Reload Timer n output

**Pin Function description (2 of 2)**

Pin name	Feature	Description
TTGn	PPG	Programmable Pulse Generator n trigger input
TTGn_R	PPG	Relocated Programmable Pulse Generator n trigger input
TXn	CAN	CAN interface n TX output
V <sub>CC</sub>	Supply	Power supply
V <sub>SS</sub>	Supply	Power supply
X0	Clock	Oscillator input
X0A	Clock	Subclock Oscillator input (only for devices with suffix "W")
X1	Clock	Oscillator output
X1A	Clock	Subclock Oscillator output (only for devices with suffix "W")

## 5. Pin Circuit Type

### Pin circuit types

FPT-48P-M26	
Pin no.	Circuit type <sup>*1</sup>
1	Supply
2	G
3 to 12	I
13, 14	B <sup>*2</sup>
13, 14	H <sup>*3</sup>
15 to 17	C
18 to 32	H
33	E
34, 35	A
36, 37	Supply
38	F
39 to 45	H
46, 47	I
48	Supply

\*1: Please refer to "6. I/O Circuit Type" for details on the I/O circuit types

\*2: Devices with suffix "W"

\*3: Devices without suffix "W"

**6. I/O Circuit Type**

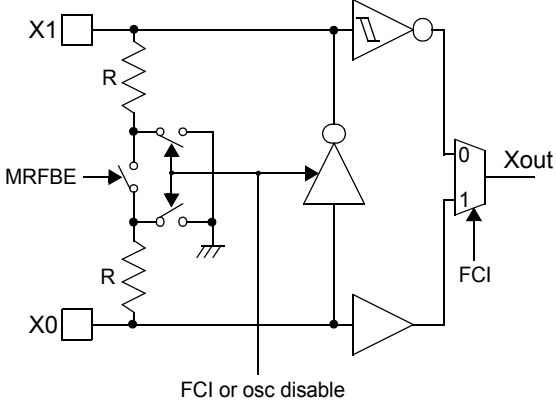
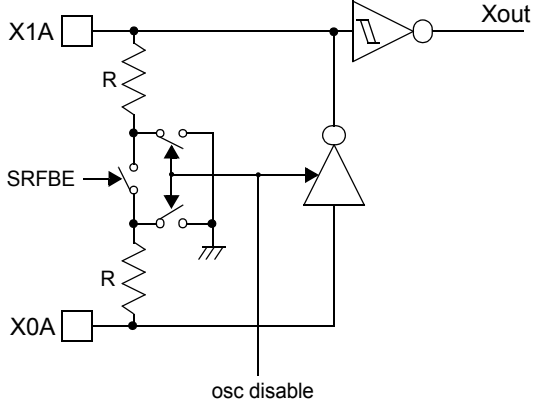
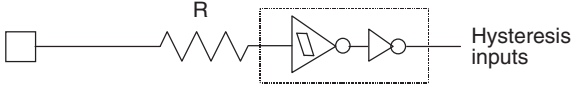
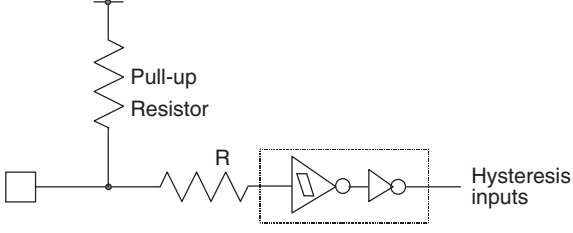
Type	Circuit	Remarks
A		<p>High-speed oscillation circuit:</p> <ul style="list-style-type: none"> <li>• Programmable between oscillation mode (external crystal or resonator connected to X0/X1 pins) and Fast external Clock Input (FCI) mode (external clock connected to X0 pin)</li> <li>• Programmable feedback resistor = approx. <math>2 * 0.5 \text{ M}\Omega</math>. Feedback resistor is grounded in the center when the oscillator is disabled or in FCI mode</li> </ul>
B		<p>Low-speed oscillation circuit:</p> <ul style="list-style-type: none"> <li>• Programmable feedback resistor = approx. <math>2 * 5 \text{ M}\Omega</math>. Feedback resistor is grounded in the center when the oscillator is disabled</li> </ul>
C		<ul style="list-style-type: none"> <li>• Mask ROM and EVA device: CMOS Hysteresis input pin</li> <li>• Flash device: CMOS input pin</li> </ul>
E		<ul style="list-style-type: none"> <li>• CMOS Hysteresis input pin</li> <li>• Pull-up resistor value: approx. <math>50 \text{ k}\Omega</math></li> </ul>

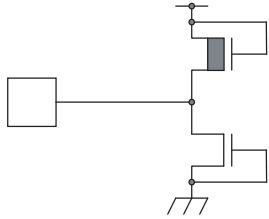
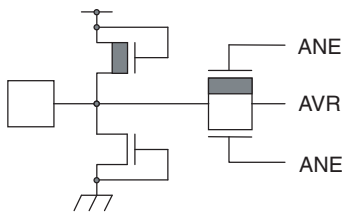
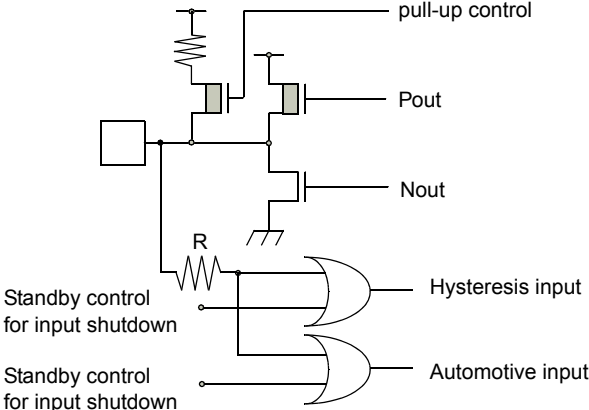
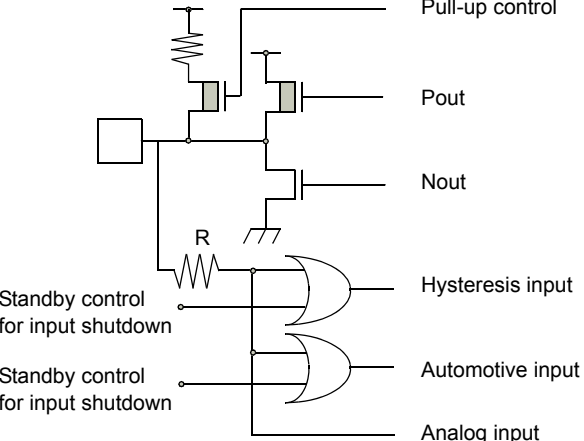
Type	Circuit	Remarks
F		<ul style="list-style-type: none"> <li>• Power supply input protection circuit</li> </ul>
G		<ul style="list-style-type: none"> <li>• A/D converter ref+ (AVRH) power supply input pin with protection circuit</li> <li>• Flash devices do not have a protection circuit against VCC for pin AVRH</li> </ul>
H		<ul style="list-style-type: none"> <li>• CMOS level output (programmable <math>I_{OL} = 5\text{mA}</math>, <math>I_{OH} = -5\text{mA}</math> and <math>I_{OL} = 2\text{mA}</math>, <math>I_{OH} = -2\text{mA}</math>)</li> <li>• CMOS hysteresis input with input shutdown function</li> <li>• Automotive input with input shutdown function</li> <li>• Programmable pull-up resistor: 50kΩ approx.</li> </ul>
I		<ul style="list-style-type: none"> <li>• CMOS level output (programmable <math>I_{OL} = 5\text{mA}</math>, <math>I_{OH} = -5\text{mA}</math> and <math>I_{OL} = 2\text{mA}</math>, <math>I_{OH} = -2\text{mA}</math>)</li> <li>• CMOS hysteresis input with input shutdown function</li> <li>• Automotive input with input shutdown function</li> <li>• Programmable pull-up resistor: 50kΩ approx.</li> <li>• Analog input</li> </ul>



**7. Memory Map**

	<b>MB96V300C</b>		<b>MB96(F)31x</b>
FF:FFF <sub>H</sub>	Emulation ROM		USER ROM / Reserved <sup>*4</sup>
DE:000 <sub>H</sub>			
	External Bus		Reserved
10:000 <sub>H</sub>			
0F:E00 <sub>H</sub>	Boot-ROM		Boot-ROM
	Reserved		
0E:000 <sub>H</sub>			
	External RAM		Reserved
02:000 <sub>H</sub>			
	Internal RAM bank 1		
01:000 <sub>H</sub>			
	ROM/RAM MIRROR		ROM/RAM MIRROR
00:800 <sub>H</sub>			
	Internal RAM bank 0	RAMSTART0 <sup>*2</sup>	Internal RAM bank 0
RAMSTART0 <sup>*</sup>			Reserved
	External Bus		
00:0C00 <sub>H</sub>			
	Peripherals		Peripherals
00:0380 <sub>H</sub>			
	GPR <sup>*1</sup>		GPR <sup>*1</sup>
00:0180 <sub>H</sub>			
	DMA		DMA
00:0100 <sub>H</sub>			
	External Bus		Reserved
00:00F0 <sub>H</sub>			
	Peripheral		Peripheral
00:0000 <sub>H</sub>			

\*1: Unused GPR banks can be used as RAM area  
 \*2: For RAMSTART0 addresses, please refer to the table on the next page.  
 \*3: For EVA device, RAMSTART0 depends on the configuration of the emulated device.  
 \*4: For details about USER ROM area, see the ■ User ROM Memory Map for Flash Devices on the following pages.  
 The DMA area is only available if the device contains the corresponding resource.  
 The available RAM and ROM area depends on the device.

## 8. RAMSTART Addresses

Devices	RAM size	RAMSTART0
MB96F313/F315	8KByte	00:6240 <sub>H</sub>

**9. User ROM Memory Map for Flash Devices**

		<b>MB96F313</b>	<b>MB96F315</b>			
Alternative mode CPU address	Flash memory mode address	Flash size 96kByte	Flash size 160kByte			
FF:FFF <sub>H</sub> FF:0000 <sub>H</sub>	3F:FFF <sub>H</sub> 3F:0000 <sub>H</sub>	S39 - 64K	S39 - 64K	Flash A		
FE:FFF <sub>H</sub> FE:0000 <sub>H</sub>	3E:FFF <sub>H</sub> 3E:0000 <sub>H</sub>	Reserved	S38 - 64K			
FD:FFF <sub>H</sub> FD:0000 <sub>H</sub>	3D:FFF <sub>H</sub> 3D:0000 <sub>H</sub>		Reserved	Reserved		
FC:FFF <sub>H</sub> FC:0000 <sub>H</sub>	3C:FFF <sub>H</sub> 3C:0000 <sub>H</sub>					
FB:FFF <sub>H</sub> FB:0000 <sub>H</sub>	3B:FFF <sub>H</sub> 3B:0000 <sub>H</sub>					
FA:FFF <sub>H</sub> FA:0000 <sub>H</sub>	3A:FFF <sub>H</sub> 3A:0000 <sub>H</sub>					
F9:FFF <sub>H</sub> F9:0000 <sub>H</sub>	39:FFF <sub>H</sub> 39:0000 <sub>H</sub>					
F8:FFF <sub>H</sub> F8:0000 <sub>H</sub>	38:FFF <sub>H</sub> 38:0000 <sub>H</sub>					
F7:FFF <sub>H</sub> F7:0000 <sub>H</sub>	37:FFF <sub>H</sub> 37:0000 <sub>H</sub>					
F6:FFF <sub>H</sub> F6:0000 <sub>H</sub>	36:FFF <sub>H</sub> 36:0000 <sub>H</sub>					
F5:FFF <sub>H</sub> F5:0000 <sub>H</sub>	35:FFF <sub>H</sub> 35:0000 <sub>H</sub>					
F4:FFF <sub>H</sub> F4:0000 <sub>H</sub>	34:FFF <sub>H</sub> 34:0000 <sub>H</sub>					
F3:FFF <sub>H</sub> F3:0000 <sub>H</sub>	33:FFF <sub>H</sub> 33:0000 <sub>H</sub>					
F2:FFF <sub>H</sub> F2:0000 <sub>H</sub>	32:FFF <sub>H</sub> 32:0000 <sub>H</sub>					
F1:FFF <sub>H</sub> F1:0000 <sub>H</sub>	31:FFF <sub>H</sub> 31:0000 <sub>H</sub>					
F0:FFF <sub>H</sub> F0:0000 <sub>H</sub>	30:FFF <sub>H</sub> 30:0000 <sub>H</sub>					
E0:FFF <sub>H</sub>					Reserved	Reserved
DF:FFF <sub>H</sub> DF:8000 <sub>H</sub>						
DF:7FF <sub>H</sub> DF:6000 <sub>H</sub>	1F:7FF <sub>H</sub> 1F:6000 <sub>H</sub>	SA3 - 8K	SA3 - 8K			
DF:5FF <sub>H</sub> DF:4000 <sub>H</sub>	1F:5FF <sub>H</sub> 1F:4000 <sub>H</sub>	SA2 - 8K	SA2 - 8K			
DF:3FF <sub>H</sub> DF:2000 <sub>H</sub>	1F:3FF <sub>H</sub> 1F:2000 <sub>H</sub>	SA1 - 8K	SA1 - 8K			
DF:1FF <sub>H</sub> DF:0000 <sub>H</sub>	1F:1FF <sub>H</sub> 1F:0000 <sub>H</sub>	SA0 - 8K *1	SA0 - 8K *1			
DE:FFF <sub>H</sub> DE:0000 <sub>H</sub>		Reserved	Reserved			

\*1: Sector SA0 contains the ROM Configuration Block RCBA at CPU address DF:0000<sub>H</sub> - DF:007F<sub>H</sub>

## 10. Serial Programming Communication Interface

USART pins for Flash serial programming (MD[2:0] = 010)

MB96F31x		
Pin number	USART Number	Normal function
LQFP-48		
7	USART2	SIN2
8		SOT2
9		SCK2
20	USART7	SIN7_R
19		SOT7_R
18		SCK7_R
22	USART8	SIN8_R
21		SOT8_R
23		SCK8_R

Note: If a Flash programmer and its software needs to use a handshaking pin, Cypress suggests to the tool vendor to support at least port P00\_1 on pin 19.

If handshaking is used by the tool but P00\_1 is not available in customer's application, Cypress suggests to the customer to check the tool manual or to contact the tool vendor for alternative handshaking pins.

## 11. I/O Map

### I/O map MB96(F)315x (Sheet 1 of 22)

Address	Register	Abbreviation 8-bit access	Abbreviation 16-bit access	Access
000000 <sub>H</sub>	I/O Port P00 - Port Data Register	PDR00		R/W
000001 <sub>H</sub>	I/O Port P01 - Port Data Register	PDR01		R/W
000002 <sub>H</sub>	I/O Port P02 - Port Data Register	PDR02		R/W
000003 <sub>H</sub>	I/O Port P03 - Port Data Register	PDR03		R/W
000004 <sub>H</sub>	Reserved			-
000005 <sub>H</sub>	I/O Port P05 - Port Data Register	PDR05		R/W
000006 <sub>H</sub>	I/O Port P06 - Port Data Register	PDR06		R/W
000007 <sub>H</sub>	I/O Port P07 - Port Data Register	PDR07		R/W
000008 <sub>H</sub> - 000017 <sub>H</sub>	Reserved			-
000018 <sub>H</sub>	ADC0 - Control Status register Low	ADCSL	ADCS	R/W
000019 <sub>H</sub>	ADC0 - Control Status register High	ADCSH		R/W
00001A <sub>H</sub>	ADC0 - Data Register Low	ADCRL	ADCR	R
00001B <sub>H</sub>	ADC0 - Data Register High	ADCRH		R
00001C <sub>H</sub>	ADC0 - Setting Register		ADSR	R/W
00001D <sub>H</sub>	ADC0 - Setting Register			R/W
00001E <sub>H</sub>	ADC0 - Extended Configuration Register	ADECR		R/W
00001F <sub>H</sub>	Reserved			-
000020 <sub>H</sub>	FRT0 - Data register of free-running timer		TCDT0	R/W
000021 <sub>H</sub>	FRT0 - Data register of free-running timer			R/W
000022 <sub>H</sub>	FRT0 - Control status register of free-running timer Low	TCCSL0	TCCS0	R/W
000023 <sub>H</sub>	FRT0 - Control status register of free-running timer High	TCCSH0		R/W
000024 <sub>H</sub>	FRT1 - Data register of free-running timer		TCDT1	R/W
000025 <sub>H</sub>	FRT1 - Data register of free-running timer			R/W
000026 <sub>H</sub>	FRT1 - Control status register of free-running timer Low	TCCSL1	TCCS1	R/W
000027 <sub>H</sub>	FRT1 - Control status register of free-running timer High	TCCSH1		R/W
000028 <sub>H</sub> - 000039 <sub>H</sub>	Reserved			-
00003A <sub>H</sub>	OCU6 - Output Compare Control Status	OCS6		R/W
00003B <sub>H</sub>	OCU7 - Output Compare Control Status	OCS7		R/W



**I/O map MB96(F)315x (Sheet 2 of 22)**

Address	Register	Abbreviation 8-bit access	Abbreviation 16-bit access	Access
00003C <sub>H</sub>	OCU6 - Compare Register		OCCP6	R/W
00003D <sub>H</sub>	OCU6 - Compare Register			R/W
00003E <sub>H</sub>	OCU7 - Compare Register		OCCP7	R/W
00003F <sub>H</sub>	OCU7 - Compare Register			R/W
000040 <sub>H</sub>	ICU0/ICU1 - Control Status Register	ICS01		R/W
000041 <sub>H</sub>	ICU0/ICU1 - Edge register	ICE01		R/W
000042 <sub>H</sub>	ICU0 - Capture Register Low	IPCPL0	IPCP0	R
000043 <sub>H</sub>	ICU0 - Capture Register High	IPCPL0		R
000044 <sub>H</sub>	ICU1 - Capture Register Low	IPCPL1	IPCP1	R
000045 <sub>H</sub>	ICU1 - Capture Register High	IPCPL1		R
000046 <sub>H</sub> - 00004B <sub>H</sub>	Reserved			-
00004C <sub>H</sub>	ICU4/ICU5 - Control Status Register	ICS45		R/W
00004D <sub>H</sub>	ICU4/ICU5 - Edge register	ICE45		R/W
00004E <sub>H</sub>	ICU4 - Capture Register Low	IPCPL4	IPCP4	R
00004F <sub>H</sub>	ICU4 - Capture Register High	IPCPL4		R
000050 <sub>H</sub>	ICU5 - Capture Register Low	IPCPL5	IPCP5	R
000051 <sub>H</sub>	ICU5 - Capture Register High	IPCPL5		R
000052 <sub>H</sub>	ICU6/ICU7 - Control Status Register	ICS67		R/W
000053 <sub>H</sub>	ICU6/ICU7 - Edge register	ICE67		R/W
000054 <sub>H</sub>	ICU6 - Capture Register Low	IPCPL6	IPCP6	R
000055 <sub>H</sub>	ICU6 - Capture Register High	IPCPL6		R
000056 <sub>H</sub>	ICU7 - Capture Register Low	IPCPL7	IPCP7	R
000057 <sub>H</sub>	ICU7 - Capture Register High	IPCPL7		R
000058 <sub>H</sub>	EXTINT0 - External Interrupt Enable Register	ENIR0		R/W
000059 <sub>H</sub>	EXTINT0 - External Interrupt Interrupt request Register	EIRR0		R/W
00005A <sub>H</sub>	EXTINT0 - External Interrupt Level Select Low	ELVRL0	ELVR0	R/W
00005B <sub>H</sub>	EXTINT0 - External Interrupt Level Select High	ELVRH0		R/W
00005C <sub>H</sub>	EXTINT1 - External Interrupt Enable Register	ENIR1		R/W
00005D <sub>H</sub>	EXTINT1 - External Interrupt Interrupt request Register	EIRR1		R/W
00005E <sub>H</sub>	EXTINT1 - External Interrupt Level Select Low	ELVRL1	ELVR1	R/W

**I/O map MB96(F)315x (Sheet 3 of 22)**

Address	Register	Abbreviation 8-bit access	Abbreviation 16-bit access	Access
00005F <sub>H</sub>	EXTINT1 - External Interrupt Level Select High	ELVRH1		R/W
000060 <sub>H</sub>	RLT0 - Timer Control Status Register Low	TMCSRL0	TMCSR0	R/W
000061 <sub>H</sub>	RLT0 - Timer Control Status Register High	TMCSRH0		R/W
000062 <sub>H</sub>	RLT0 - Reload Register - for writing		TMRLR0	W
000062 <sub>H</sub>	RLT0 - Reload Register - for reading		TMR0	R
000063 <sub>H</sub>	RLT0 - Reload Register - for writing			W
000063 <sub>H</sub>	RLT0 - Reload Register - for reading			R
000064 <sub>H</sub>	RLT1 - Timer Control Status Register Low	TMCSRL1	TMCSR1	R/W
000065 <sub>H</sub>	RLT1 - Timer Control Status Register High	TMCSRH1		R/W
000066 <sub>H</sub>	RLT1 - Reload Register - for writing		TMRLR1	W
000066 <sub>H</sub>	RLT1 - Reload Register - for reading		TMR1	R
000067 <sub>H</sub>	RLT1 - Reload Register - for writing			W
000067 <sub>H</sub>	RLT1 - Reload Register - for reading			R
000068 <sub>H</sub>	RLT2 - Timer Control Status Register Low	TMCSRL2	TMCSR2	R/W
000069 <sub>H</sub>	RLT2 - Timer Control Status Register High	TMCSRH2		R/W
00006A <sub>H</sub>	RLT2 - Reload Register - for writing		TMRLR2	W
00006A <sub>H</sub>	RLT2 - Reload Register - for reading		TMR2	R
00006B <sub>H</sub>	RLT2 - Reload Register - for writing			W
00006B <sub>H</sub>	RLT2 - Reload Register - for reading			R
00006C <sub>H</sub>	RLT3 - Timer Control Status Register Low	TMCSRL3	TMCSR3	R/W
00006D <sub>H</sub>	RLT3 - Timer Control Status Register High	TMCSRH3		R/W
00006E <sub>H</sub>	RLT3 - Reload Register - for writing		TMRLR3	W
00006E <sub>H</sub>	RLT3 - Reload Register - for reading		TMR3	R
00006F <sub>H</sub>	RLT3 - Reload Register - for writing			W
00006F <sub>H</sub>	RLT3 - Reload Register - for reading			R
000070 <sub>H</sub>	RLT6 - Timer Control Status Register Low (dedic. RLT for PPG)	TMCSRL6	TMCSR6	R/W
000071 <sub>H</sub>	RLT6 - Timer Control Status Register High (dedic. RLT for PPG)	TMCSRH6		R/W
000072 <sub>H</sub>	RLT6 - Reload Register (dedic. RLT for PPG) - for writing		TMRLR6	W
000072 <sub>H</sub>	RLT6 - Reload Register (dedic. RLT for PPG) - for reading		TMR6	R

**I/O map MB96(F)315x (Sheet 4 of 22)**

Address	Register	Abbreviation 8-bit access	Abbreviation 16-bit access	Access
000073 <sub>H</sub>	RLT6 - Reload Register (dedic. RLT for PPG) - for writing			W
000073 <sub>H</sub>	RLT6 - Reload Register (dedic. RLT for PPG) - for reading			R
000074 <sub>H</sub>	PPG3-PPG0 - General Control register 1 Low	GCN1L0	GCN10	R/W
000075 <sub>H</sub>	PPG3-PPG0 - General Control register 1 High	GCN1H0		R/W
000076 <sub>H</sub>	PPG3-PPG0 - General Control register 2 Low	GCN2L0	GCN20	R/W
000077 <sub>H</sub>	PPG3-PPG0 - General Control register 2 High	GCN2H0		R/W
000078 <sub>H</sub>	PPG0 - Timer register		PTMR0	R
000079 <sub>H</sub>	PPG0 - Timer register			R
00007A <sub>H</sub>	PPG0 - Period setting register		PCSR0	W
00007B <sub>H</sub>	PPG0 - Period setting register			W
00007C <sub>H</sub>	PPG0 - Duty cycle register		PDUT0	W
00007D <sub>H</sub>	PPG0 - Duty cycle register			W
00007E <sub>H</sub>	PPG0 - Control status register Low	PCNL0	PCN0	R/W
00007F <sub>H</sub>	PPG0 - Control status register High	PCNH0		R/W
000080 <sub>H</sub>	PPG1 - Timer register		PTMR1	R
000081 <sub>H</sub>	PPG1 - Timer register			R
000082 <sub>H</sub>	PPG1 - Period setting register		PCSR1	W
000083 <sub>H</sub>	PPG1 - Period setting register			W
000084 <sub>H</sub>	PPG1 - Duty cycle register		PDUT1	W
000085 <sub>H</sub>	PPG1 - Duty cycle register			W
000086 <sub>H</sub>	PPG1 - Control status register Low	PCNL1	PCN1	R/W
000087 <sub>H</sub>	PPG1 - Control status register High	PCNH1		R/W
000088 <sub>H</sub> 00008F <sub>H</sub>	Reserved			-
000090 <sub>H</sub>	PPG3 - Timer register		PTMR3	R
000091 <sub>H</sub>	PPG3 - Timer register			R
000092 <sub>H</sub>	PPG3 - Period setting register		PCSR3	W
000093 <sub>H</sub>	PPG3 - Period setting register			W
000094 <sub>H</sub>	PPG3 - Duty cycle register		PDUT3	W
000095 <sub>H</sub>	PPG3 - Duty cycle register			W
000096 <sub>H</sub>	PPG3 - Control status register Low	PCNL3	PCN3	R/W

**I/O map MB96(F)315x (Sheet 5 of 22)**

Address	Register	Abbreviation 8-bit access	Abbreviation 16-bit access	Access
000097 <sub>H</sub>	PPG3 - Control status register High	PCNH3		R/W
000098 <sub>H</sub>	PPG7-PPG4 - General Control register 1 Low	GCN1L1	GCN11	R/W
000099 <sub>H</sub>	PPG7-PPG4 - General Control register 1 High	GCN1H1		R/W
00009A <sub>H</sub>	PPG7-PPG4 - General Control register 2 Low	GCN2L1	GCN21	R/W
00009B <sub>H</sub>	PPG7-PPG4 - General Control register 2 High	GCN2H1		R/W
00009C <sub>H</sub>	PPG4 - Timer register		PTMR4	R
00009D <sub>H</sub>	PPG4 - Timer register			R
00009E <sub>H</sub>	PPG4 - Period setting register		PCSR4	W
00009F <sub>H</sub>	PPG4 - Period setting register			W
0000A0 <sub>H</sub>	PPG4 - Duty cycle register		PDUT4	W
0000A1 <sub>H</sub>	PPG4 - Duty cycle register			W
0000A2 <sub>H</sub>	PPG4 - Control status register Low	PCNL4	PCN4	R/W
0000A3 <sub>H</sub>	PPG4 - Control status register High	PCNH4		R/W
0000A4 <sub>H</sub> - 0000D3 <sub>H</sub>	Reserved			-
0000D4 <sub>H</sub>	USART2 - Serial Mode Register	SMR2		R/W
0000D5 <sub>H</sub>	USART2 - Serial Control Register	SCR2		R/W
0000D6 <sub>H</sub>	USART2 - TX Register	TDR2		W
0000D6 <sub>H</sub>	USART2 - RX Register	RDR2		R
0000D7 <sub>H</sub>	USART2 - Serial Status	SSR2		R/W
0000D8 <sub>H</sub>	USART2 - Control/Com. Register	ECCR2		R/W
0000D9 <sub>H</sub>	USART2 - Ext. Status Register	ESCR2		R/W
0000DA <sub>H</sub>	USART2 - Baud Rate Generator Register Low	BGRL2	BGR2	R/W
0000DB <sub>H</sub>	USART2 - Baud Rate Generator Register High	BGRH2		R/W
0000DC <sub>H</sub>	USART2 - Extended Serial Interrupt Register	ESIR2		R/W
0000DD <sub>H</sub> - 0000FF <sub>H</sub>	Reserved			-
000100 <sub>H</sub>	DMA0 - Buffer address pointer low byte	BAPL0		R/W
000101 <sub>H</sub>	DMA0 - Buffer address pointer middle byte	BAPM0		R/W
000102 <sub>H</sub>	DMA0 - Buffer address pointer high byte	BAPH0		R/W
000103 <sub>H</sub>	DMA0 - DMA control register	DMACS0		R/W

**I/O map MB96(F)315x (Sheet 6 of 22)**

Address	Register	Abbreviation 8-bit access	Abbreviation 16-bit access	Access
000104 <sub>H</sub>	DMA0 - I/O register address pointer low byte	IOAL0	IOA0	R/W
000105 <sub>H</sub>	DMA0 - I/O register address pointer high byte	IOAH0		R/W
000106 <sub>H</sub>	DMA0 - Data counter low byte	DCTL0	DCT0	R/W
000107 <sub>H</sub>	DMA0 - Data counter high byte	DCTH0		R/W
000108 <sub>H</sub>	DMA1 - Buffer address pointer low byte	BAPL1		R/W
000109 <sub>H</sub>	DMA1 - Buffer address pointer middle byte	BAPM1		R/W
00010A <sub>H</sub>	DMA1 - Buffer address pointer high byte	BAPH1		R/W
00010B <sub>H</sub>	DMA1 - DMA control register	DMACS1		R/W
00010C <sub>H</sub>	DMA1 - I/O register address pointer low byte	IOAL1	IOA1	R/W
00010D <sub>H</sub>	DMA1 - I/O register address pointer high byte	IOAH1		R/W
00010E <sub>H</sub>	DMA1 - Data counter low byte	DCTL1	DCT1	R/W
00010F <sub>H</sub>	DMA1 - Data counter high byte	DCTH1		R/W
000110 <sub>H</sub>	DMA2 - Buffer address pointer low byte	BAPL2		R/W
000111 <sub>H</sub>	DMA2 - Buffer address pointer middle byte	BAPM2		R/W
000112 <sub>H</sub>	DMA2 - Buffer address pointer high byte	BAPH2		R/W
000113 <sub>H</sub>	DMA2 - DMA control register	DMACS2		R/W
000114 <sub>H</sub>	DMA2 - I/O register address pointer low byte	IOAL2	IOA2	R/W
000115 <sub>H</sub>	DMA2 - I/O register address pointer high byte	IOAH2		R/W
000116 <sub>H</sub>	DMA2 - Data counter low byte	DCTL2	DCT2	R/W
000117 <sub>H</sub>	DMA2 - Data counter high byte	DCTH2		R/W
000118 <sub>H</sub>	DMA3 - Buffer address pointer low byte	BAPL3		R/W
000119 <sub>H</sub>	DMA3 - Buffer address pointer middle byte	BAPM3		R/W
00011A <sub>H</sub>	DMA3 - Buffer address pointer high byte	BAPH3		R/W
00011B <sub>H</sub>	DMA3 - DMA control register	DMACS3		R/W
00011C <sub>H</sub>	DMA3 - I/O register address pointer low byte	IOAL3	IOA3	R/W
00011D <sub>H</sub>	DMA3 - I/O register address pointer high byte	IOAH3		R/W
00011E <sub>H</sub>	DMA3 - Data counter low byte	DCTL3	DCT3	R/W
00011F <sub>H</sub>	DMA3 - Data counter high byte	DCTH3		R/W
000120 <sub>H</sub> 00017F <sub>H</sub>	Reserved			-



**I/O map MB96(F)315x (Sheet 7 of 22)**

Address	Register	Abbreviation 8-bit access	Abbreviation 16-bit access	Access
000180 <sub>H</sub> - 00037F <sub>H</sub>	CPU - General Purpose registers (RAM access)	GPR_RAM		R/W
000380 <sub>H</sub>	DMA0 - Interrupt select	DISEL0		R/W
000381 <sub>H</sub>	DMA1 - Interrupt select	DISEL1		R/W
000382 <sub>H</sub>	DMA2 - Interrupt select	DISEL2		R/W
000383 <sub>H</sub>	DMA3 - Interrupt select	DISEL3		R/W
000384 <sub>H</sub> - 00038F <sub>H</sub>	Reserved			-
000390 <sub>H</sub>	DMA - Status register low byte	DSRL	DSR	R/W
000391 <sub>H</sub>	DMA - Status register high byte	DSRH		R/W
000392 <sub>H</sub>	DMA - Stop status register low byte	DSSRL	DSSR	R/W
000393 <sub>H</sub>	DMA - Stop status register high byte	DSSRH		R/W
000394 <sub>H</sub>	DMA - Enable register low byte	DERL	DER	R/W
000395 <sub>H</sub>	DMA - Enable register high byte	DERH		R/W
000396 <sub>H</sub> - 00039F <sub>H</sub>	Reserved			-
0003A0 <sub>H</sub>	Interrupt level register	ILR	ICR	R/W
0003A1 <sub>H</sub>	Interrupt index register	IDX		R/W
0003A2 <sub>H</sub>	Interrupt vector table base register Low	TBRL	TBR	R/W
0003A3 <sub>H</sub>	Interrupt vector table base register High	TBRH		R/W
0003A4 <sub>H</sub>	Delayed Interrupt register	DIRR		R/W
0003A5 <sub>H</sub>	Non Maskable Interrupt register	NMI		R/W
0003A6 <sub>H</sub> - 0003AB <sub>H</sub>	Reserved			-
0003AC <sub>H</sub>	EDSU communication interrupt selection Low	EDSU2L	EDSU2	R/W
0003AD <sub>H</sub>	EDSU communication interrupt selection High	EDSU2H		R/W
0003AE <sub>H</sub>	ROM mirror control register	ROMM		R/W
0003AF <sub>H</sub>	EDSU configuration register	EDSU		R/W
0003B0 <sub>H</sub>	Memory patch control/status register ch 0/1		PFCS0	R/W
0003B1 <sub>H</sub>	Memory patch control/status register ch 0/1			R/W
0003B2 <sub>H</sub>	Memory patch control/status register ch 2/3		PFCS1	R/W
0003B3 <sub>H</sub>	Memory patch control/status register ch 2/3			R/W

**I/O map MB96(F)315x (Sheet 8 of 22)**

Address	Register	Abbreviation 8-bit access	Abbreviation 16-bit access	Access
0003B4 <sub>H</sub>	Memory patch control/status register ch 4/5		PFCS2	R/W
0003B5 <sub>H</sub>	Memory patch control/status register ch 4/5			R/W
0003B6 <sub>H</sub>	Memory patch control/status register ch 6/7		PFCS3	R/W
0003B7 <sub>H</sub>	Memory patch control/status register ch 6/7			R/W
0003B8 <sub>H</sub>	Memory Patch function - Patch address 0 low	PFAL0		R/W
0003B9 <sub>H</sub>	Memory Patch function - Patch address 0 middle	PFAM0		R/W
0003BA <sub>H</sub>	Memory Patch function - Patch address 0 high	PFAH0		R/W
0003BB <sub>H</sub>	Memory Patch function - Patch address 1 low	PFAL1		R/W
0003BC <sub>H</sub>	Memory Patch function - Patch address 1 middle	PFAM1		R/W
0003BD <sub>H</sub>	Memory Patch function - Patch address 1 high	PFAH1		R/W
0003BE <sub>H</sub>	Memory Patch function - Patch address 2 low	PFAL2		R/W
0003BF <sub>H</sub>	Memory Patch function - Patch address 2 middle	PFAM2		R/W
0003C0 <sub>H</sub>	Memory Patch function - Patch address 2 high	PFAH2		R/W
0003C1 <sub>H</sub>	Memory Patch function - Patch address 3 low	PFAL3		R/W
0003C2 <sub>H</sub>	Memory Patch function - Patch address 3 middle	PFAM3		R/W
0003C3 <sub>H</sub>	Memory Patch function - Patch address 3 high	PFAH3		R/W
0003C4 <sub>H</sub>	Memory Patch function - Patch address 4 low	PFAL4		R/W
0003C5 <sub>H</sub>	Memory Patch function - Patch address 4 middle	PFAM4		R/W
0003C6 <sub>H</sub>	Memory Patch function - Patch address 4 high	PFAH4		R/W
0003C7 <sub>H</sub>	Memory Patch function - Patch address 5 low	PFAL5		R/W
0003C8 <sub>H</sub>	Memory Patch function - Patch address 5 middle	PFAM5		R/W
0003C9 <sub>H</sub>	Memory Patch function - Patch address 5 high	PFAH5		R/W
0003CA <sub>H</sub>	Memory Patch function - Patch address 6 low	PFAL6		R/W
0003CB <sub>H</sub>	Memory Patch function - Patch address 6 middle	PFAM6		R/W
0003CC <sub>H</sub>	Memory Patch function - Patch address 6 high	PFAH6		R/W
0003CD <sub>H</sub>	Memory Patch function - Patch address 7 low	PFAL7		R/W
0003CE <sub>H</sub>	Memory Patch function - Patch address 7 middle	PFAM7		R/W
0003CF <sub>H</sub>	Memory Patch function - Patch address 7 high	PFAH7		R/W
0003D0 <sub>H</sub>	Memory Patch function - Patch data 0 Low	PFDL0	PFD0	R/W
0003D1 <sub>H</sub>	Memory Patch function - Patch data 0 High	PFDH0		R/W

**I/O map MB96(F)315x (Sheet 9 of 22)**

Address	Register	Abbreviation 8-bit access	Abbreviation 16-bit access	Access
0003D2 <sub>H</sub>	Memory Patch function - Patch data 1 Low	PFDL1	PFD1	R/W
0003D3 <sub>H</sub>	Memory Patch function - Patch data 1 High	PFDH1		R/W
0003D4 <sub>H</sub>	Memory Patch function - Patch data 2 Low	PFDL2	PFD2	R/W
0003D5 <sub>H</sub>	Memory Patch function - Patch data 2 High	PFDH2		R/W
0003D6 <sub>H</sub>	Memory Patch function - Patch data 3 Low	PFDL3	PFD3	R/W
0003D7 <sub>H</sub>	Memory Patch function - Patch data 3 High	PFDH3		R/W
0003D8 <sub>H</sub>	Memory Patch function - Patch data 4 Low	PFDL4	PFD4	R/W
0003D9 <sub>H</sub>	Memory Patch function - Patch data 4 High	PFDH4		R/W
0003DA <sub>H</sub>	Memory Patch function - Patch data 5 Low	PFDL5	PFD5	R/W
0003DB <sub>H</sub>	Memory Patch function - Patch data 5 High	PFDH5		R/W
0003DC <sub>H</sub>	Memory Patch function - Patch data 6 Low	PFDL6	PFD6	R/W
0003DD <sub>H</sub>	Memory Patch function - Patch data 6 High	PFDH6		R/W
0003DE <sub>H</sub>	Memory Patch function - Patch data 7 Low	PFDL7	PFD7	R/W
0003DF <sub>H</sub>	Memory Patch function - Patch data 7 High	PFDH7		R/W
0003E0 <sub>H</sub> - 0003F0 <sub>H</sub>	Reserved			-
0003F1 <sub>H</sub>	Memory Control Status Register A	MCSRA		R/W
0003F2 <sub>H</sub>	Memory Timing Configuration Register A Low	MTCRAL	MTCRA	R/W
0003F3 <sub>H</sub>	Memory Timing Configuration Register A High	MTCRAH		R/W
0003F4 <sub>H</sub> - 0003F8 <sub>H</sub>	Reserved			-
0003F9 <sub>H</sub>	Flash Memory Write Control register 1	FMWC1		R/W
0003FA <sub>H</sub>	Flash Memory Write Control register 2	FMWC2		R/W
0003FB <sub>H</sub>	Flash Memory Write Control register 3	FMWC3		R/W
0003FC <sub>H</sub>	Flash Memory Write Control register 4	FMWC4		R/W
0003FD <sub>H</sub>	Flash Memory Write Control register 5	FMWC5		R/W
0003FE <sub>H</sub> - 0003FF <sub>H</sub>	Reserved			-
000400 <sub>H</sub>	Standby Mode control register	SMCR		R/W
000401 <sub>H</sub>	Clock select register	CKSR		R/W
000402 <sub>H</sub>	Clock Stabilization select register	CKSSR		R/W
000403 <sub>H</sub>	Clock monitor register	CKMR		R