



Chipsmall Limited consists of a professional team with an average of over 10 year of expertise in the distribution of electronic components. Based in Hongkong, we have already established firm and mutual-benefit business relationships with customers from,Europe,America and south Asia,supplying obsolete and hard-to-find components to meet their specific needs.

With the principle of “Quality Parts,Customers Priority,Honest Operation,and Considerate Service”,our business mainly focus on the distribution of electronic components. Line cards we deal with include Microchip,ALPS,ROHM,Xilinx,Pulse,ON,Everlight and Freescale. Main products comprise IC,Modules,Potentiometer,IC Socket,Relay,Connector.Our parts cover such applications as commercial,industrial, and automotives areas.

We are looking forward to setting up business relationship with you and hope to provide you with the best service and solution. Let us make a better world for our industry!



Contact us

Tel: +86-755-8981 8866 Fax: +86-755-8427 6832

Email & Skype: info@chipsmall.com Web: www.chipsmall.com

Address: A1208, Overseas Decoration Building, #122 Zhenhua RD., Futian, Shenzhen, China



The Freescale MC100ES6254 is a bipolar monolithic differential 2x2 clock switch and fanout buffer. Designed for most demanding clock distribution systems, the MC100ES6254 supports various applications that require a large number of outputs to drive precisely aligned clock signals. The device is capable of driving and switching differential LVPECL signals. Using SiGe technology and a fully differential architecture, the device offers superior digital signal characteristics and very low clock skew error. Target applications for this clock driver are high performance clock/data switching, clock distribution or data loopback in computing, networking and telecommunication systems.

Features

- Fully differential architecture from input to all outputs
- SiGe technology supports near-zero output skew
- Supports DC to 3GHz operation⁽¹⁾ of clock or data signals
- LVPECL compatible differential clock inputs and outputs
- LVCMOS compatible control inputs
- Single 3.3 V or 2.5 V supply
- 50 ps maximum device skew⁽¹⁾
- Synchronous output enable eliminating output runt pulse generation and metastability
- Standard 32 lead LQFP package
- Industrial temperature range
- 32-lead Pb-free package

Functional Description

MC100ES6254 is designed for very skew critical differential clock distribution systems and supports clock frequencies from DC up to 3.0GHz. Typical applications for the MC100ES6254 are primary clock distribution, switching and loopback systems of high-performance computer, networking and telecommunication systems, as well as on-board clocking of OC-3, OC-12 and OC-48 speed communication systems. Primary purpose of the MC100ES6254 is high-speed clock switching applications. In addition, the MC100ES6254 can be configured as single 1:6 or dual 1:3 LVPECL fanout buffer for clock signals, or as loopback device in high-speed data applications.

The MC100ES6254 can be operated from a 3.3 V or 2.5 V positive supply without the requirement of a negative supply line.

**2.5/3.3 V DIFFERENTIAL
LVPECL 2x2
CLOCK SWITCH
AND FANOUT BUFFER**



**AC SUFFIX
32-LEAD LQFP PACKAGE
Pb-FREE PACKAGE
CASE 873A-04**

ORDERING INFORMATION

Device	Package
MC100ES6254AC	LQFP-32 (Pb-Free)
MC100ES6254ACR2	LQFP-32 (Pb-Free)

1. The device is functional up to 3GHz and characterized up to 2.7GHz.

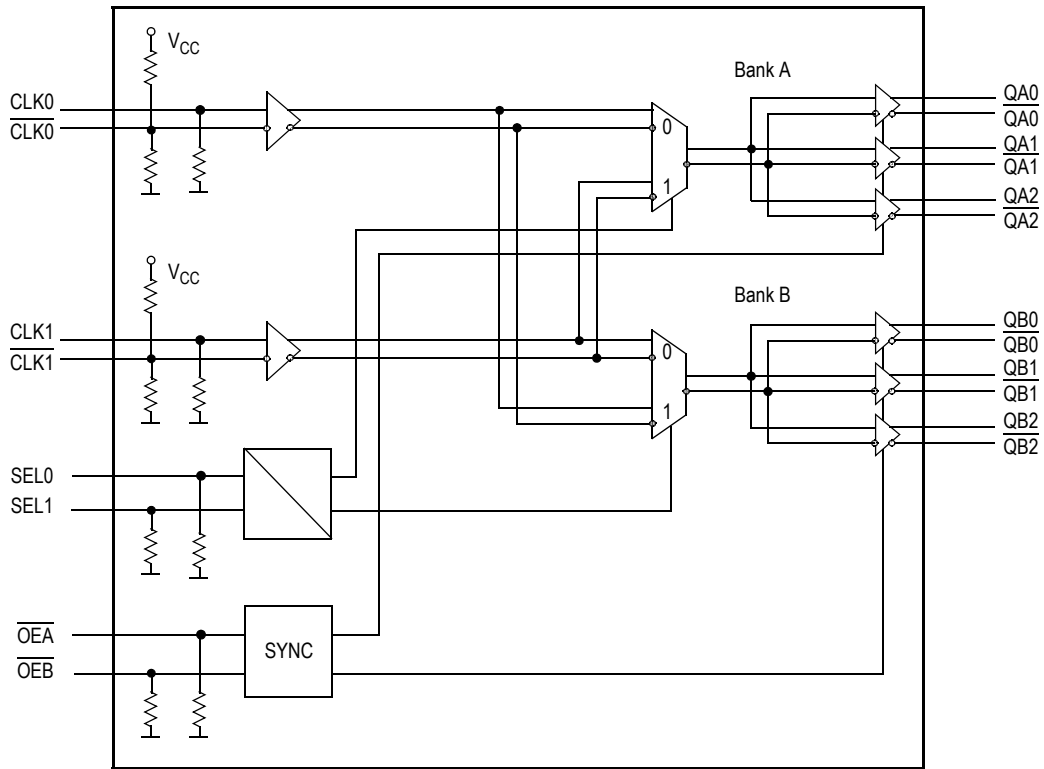

Figure 1. MC100ES6254 Logic Diagram

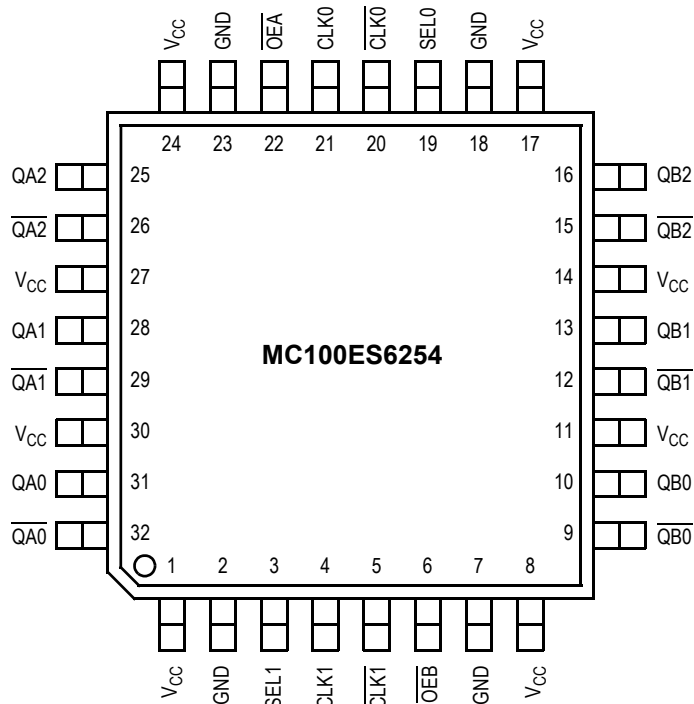

Figure 2. 32-Lead Package Pinout (Top View)

Table 1. Pin Configuration

Pin	I/O	Type	Function
CLK0, $\overline{\text{CLK0}}$	Input	LVPECL	Differential reference clock signal input 0
CLK1, $\overline{\text{CLK1}}$	Input	LVPECL	Differential reference clock signal input 1
$\overline{\text{OEA}}$, $\overline{\text{OEB}}$	Input	LVC MOS	Output enable
SEL0, SEL1	Input	LVC MOS	Clock switch select
QA[0:2], $\overline{\text{QA[0:2]}}$ QB[0:2], $\overline{\text{QB[0:2]}}$	Output	LVPECL	Differential clock outputs (banks A and B)
GND	Supply	GND	Negative power supply
V _{CC}	Supply	VCC	Positive power supply. All V _{CC} pins must be connected to the positive power supply for correct DC and AC operation

Table 2. Function Table

Control	Default	0	1
$\overline{\text{OEA}}$	0	QA[0:2], $\overline{\text{Qx[0:2]}}$ are active. Deassertion of $\overline{\text{OE}}$ can be asynchronous to the reference clock without generation of output runt pulses	QA[0:2] = L, $\overline{\text{QA[0:2]}}$ = H (outputs disabled). Assertion of $\overline{\text{OE}}$ can be asynchronous to the reference clock without generation of output runt pulses
$\overline{\text{OEB}}$	0	QA[0:2], $\overline{\text{Qx[0:2]}}$ are active. Deassertion of $\overline{\text{OE}}$ can be asynchronous to the reference clock without generation of output runt pulses	QA[0:2] = L, $\overline{\text{QA[0:2]}}$ = H (outputs disabled). Assertion of $\overline{\text{OE}}$ can be asynchronous to the reference clock without generation of output runt pulses
SEL0, SEL1	00	Refer to Table 4	

Table 3. Clock Select Control

SEL0	SEL1	CLK0 Routed to	CLK1 Routed to	Application Mode
0	0	QA[0:2] and QB[0:2]	—	1:6 fanout of CLK0
0	1	—	QA[0:2] and QB[0:2]	1:6 fanout of CLK1
1	0	QA[0:2]	QB[0:2]	Dual 1:3 buffer
1	1	QB[0:2]	QA[0:2]	Dual 1:3 buffer (crossed)

Table 4. Absolute Maximum Ratings⁽¹⁾

Symbol	Characteristics	Min	Max	Unit	Condition
V _{CC}	Supply Voltage	-0.3	3.6	V	
V _{IN}	DC Input Voltage	-0.3	V _{CC} +0.3	V	
V _{OUT}	DC Output Voltage	-0.3	V _{CC} +0.3	V	
I _{IN}	DC Input Current		±20	mA	
I _{OUT}	DC Output Current		±50	mA	
T _S	Storage Temperature	-65	125	°C	

1. Absolute maximum continuous ratings are those maximum values beyond which damage to the device may occur. Exposure to these conditions or conditions beyond those indicated may adversely affect device reliability. Functional operation at absolute-maximum-rated conditions is not implied.

Table 5. General Specifications

Symbol	Characteristics	Min	Typ	Max	Unit	Condition
V_{TT}	Output termination voltage		$V_{CC}-2^{(1)}$		V	
MM	ESD Protection (Machine model)	200			V	
HBM	ESD Protection (Human body model)	2000			V	
CDM	ESD Protection (Charged device model)	1500			V	
LU	Latch-up immunity	200			mA	
C_{IN}			4.0		pF	Inputs
θ_{JA}	Thermal resistance junction to ambient JESD 51-3, single layer test board		83.1 73.3 68.9 63.8 57.4	86.0 75.4 70.9 65.3 59.6	$^{\circ}\text{C}/\text{W}$ $^{\circ}\text{C}/\text{W}$ $^{\circ}\text{C}/\text{W}$ $^{\circ}\text{C}/\text{W}$ $^{\circ}\text{C}/\text{W}$	Natural convection 100 ft/min 200 ft/min 400 ft/min 800 ft/min
	JESD 51-6, 2S2P multilayer test board		59.0 54.4 52.5 50.4 47.8	60.6 55.7 53.8 51.5 48.8	$^{\circ}\text{C}/\text{W}$ $^{\circ}\text{C}/\text{W}$ $^{\circ}\text{C}/\text{W}$ $^{\circ}\text{C}/\text{W}$ $^{\circ}\text{C}/\text{W}$	Natural convection 100 ft/min 200 ft/min 400 ft/min 800 ft/min
θ_{JC}	Thermal resistance junction to case		23.0	26.3	$^{\circ}\text{C}/\text{W}$	MIL-SPEC 883E Method 1012.1
	Operating junction temperature ⁽²⁾ (continuous operation) MTBF = 9.1 years			110	$^{\circ}\text{C}$	
T_{Func}	Functional temperature range	$T_A = -40$		$T_J = +110$	$^{\circ}\text{C}$	

1. Output termination voltage $V_{TT} = 0\text{ V}$ for $V_{CC} = 2.5\text{ V}$ operation is supported but the power consumption of the device will increase.
2. Operating junction temperature impacts device life time. Maximum continuous operating junction temperature should be selected according to the application life time requirements (See application note AN1545 and the application section in this data sheet for more information). The device AC and DC parameters are specified up to 110°C junction temperature allowing the MC100ES6254 to be used in applications requiring industrial temperature range. It is recommended that users of the MC100ES6254 employ thermal modeling analysis to assist in applying the junction temperature specifications to their particular application.

Table 6. DC Characteristics ($V_{CC} = 3.3\text{ V} \pm 5\%$ or $2.5\text{ V} \pm 5\%$, $T_J = 0^\circ$ to $+110^\circ\text{C}$)

Symbol	Characteristics	Min	Typ	Max	Unit	Condition
LVCMOS Control Inputs ($\overline{\text{OEA}}$, $\overline{\text{OEB}}$, $\overline{\text{SEL0}}$, $\overline{\text{SEL1}}$)						
V_{IL}	Input Voltage Low			0.8	V	
V_{IH}	Input Voltage High	2.0			V	
I_{IN}	Input Current ⁽¹⁾			± 100	μA	$V_{IN} = V_{CC}$ or $V_{IN} = \text{GND}$
+ Clock Inputs ($\overline{\text{CLK0}}$, $\overline{\text{CLK1}}$)						
V_{PP}	AC differential input voltage ⁽²⁾	0.1		1.3	V	Differential operation
V_{CMR}	Differential cross point voltage ⁽³⁾	1.0		$V_{CC}-0.3$	V	Differential operation
LVPECL Clock Outputs ($\overline{\text{QA0-2}}$, $\overline{\text{QA0-2}}$, $\overline{\text{QB0-2}}$, $\overline{\text{QB0-2}}$)						
V_{OH}	Output High Voltage	$V_{CC}-1.2$	$V_{CC}-1.005$	$V_{CC}-0.7$	V	$I_{OH} = -30\text{ mA}$ ⁽⁴⁾
V_{OL}	Output Low Voltage	$V_{CC}-1.9$ $V_{CC}-1.9$	$V_{CC}-1.705$ $V_{CC}-1.705$	$V_{CC}-1.5$ $V_{CC}-1.3$	V	$I_{OL} = -5\text{ mA}$ ⁽⁵⁾
Supply Current						
I_{GND}	Maximum Quiescent Supply Current without output termination current		52	85	mA	GND pin

- Inputs have internal pullup/pulldown resistors that affect the input current.
- V_{PP} is the minimum differential input voltage swing required to maintain AC characteristic.
- V_{CMR} (DC) is the crosspoint of the differential input signal. Functional operation is obtained when the crosspoint is within the V_{CMR} (DC) range and the input swing lies within the V_{PP} (DC) specification.
- Equivalent to a termination $50\ \Omega$ to V_{TT} .
- I_{CC} calculation: $I_{CC} = (\text{number of differential output pairs used}) * (I_{OH} + I_{OL}) + I_{GND}$
 $I_{CC} = (\text{number of differential output pairs used}) * (V_{OH}-V_{TT})\div R_{load} + (V_{OL}-V_{TT})\div R_{load} + I_{GND}$

Table 7. AC Characteristics ($V_{CC} = 3.3\text{ V} \pm 5\%$ or $2.5\text{ V} \pm 5\%$, $T_J = 0^\circ$ to $+110^\circ\text{C}$)⁽¹⁾

Symbol	Characteristics	Min	Typ	Max	Unit	Condition
V_{PP}	Differential Input Voltage ⁽²⁾ (peak-to-peak)	0.3		1.3	V	
V_{CMR}	Differential Input Crosspoint Voltage ⁽³⁾	1.2		$V_{CC}-0.3$	V	
$V_{O(P-P)}$	Differential Output Voltage (peak-to-peak)					
	$f_O < 1.1\text{GHz}$	0.45	0.7		V	
	$f_O < 2.5\text{GHz}$	0.35	0.55		V	
	$f_O < 3.0\text{GHz}$	0.20	0.35		V	
f_{CLK}	Input Frequency	0		$3000^{(4)}$	MHz	
t_{PD}	Propagation Delay CLK, 1 to QA[] or QB[]	360	485	610	ps	Differential
$t_{sk(O)}$	Output-to-Output Skew			50	ps	Differential
$t_{sk(PP)}$	Output-to-Output Skew (part-to-part)			250	ps	Differential
$t_{sk(P)}$	Output Pulse Skew ⁽⁵⁾			60	ps	
DC_O	Output Duty Cycle				%	$DC_{fref} = 50\%$
	$t_{REF} < 100\text{MHz}$	49.4		50.6	%	$DC_{fref} = 50\%$
	$t_{REF} < 800\text{MHz}$	45.2		54.8	%	$DC_{fref} = 50\%$
$t_{JIT(CC)}$	Output Cycle-to-Cycle Jitter (SEL0 \neq SEL1)			TBD		
t_r, t_f	Output Rise/Fall Time	0.05		300	ps	20% to 80%
$t_{PDL}^{(6)}$	Output Disable Time	$2.5 \cdot T + t_{PD}$		$3.5 \cdot T + t_{PD}$	ns	$T = \text{CLK period}$
$t_{PLD}^{(7)}$	Output Enable Time	$3 \cdot T + t_{PD}$		$4 \cdot T + t_{PD}$	ns	$T = \text{CLK period}$

- AC characteristics apply for parallel output termination of $50\ \Omega$ to V_{TT} .
- V_{PP} is the minimum differential input voltage swing required to maintain AC characteristics including t_{PD} and device-to-device skew.
- V_{CMR} (AC) is the crosspoint of the differential input signal. Normal AC operation is obtained when the crosspoint is within the V_{CMR} (AC) range and the input swing lies within the V_{PP} (AC) specification. Violation of V_{CMR} (AC) or V_{PP} (AC) impacts the device propagation delay, device and part-to-part skew.
- The MC100ES6254 is fully operational up to 3.0 GHz and is characterized up to 2.7GHz.
- Output pulse skew is the absolute difference of the propagation delay times: $|t_{PLH} - t_{PHL}|$.
- Propagation delay \overline{OE} deassertion to differential output disabled (differential low: true output low, complementary output high).
- Propagation delay \overline{OE} assertion to output enabled (active).

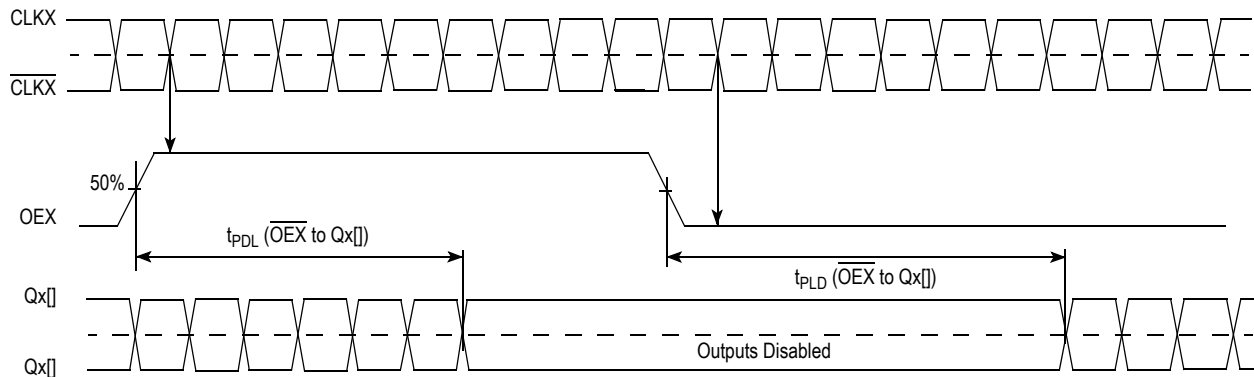
**Figure 3. MC100ES6254 Output Disable/Enable Timing**

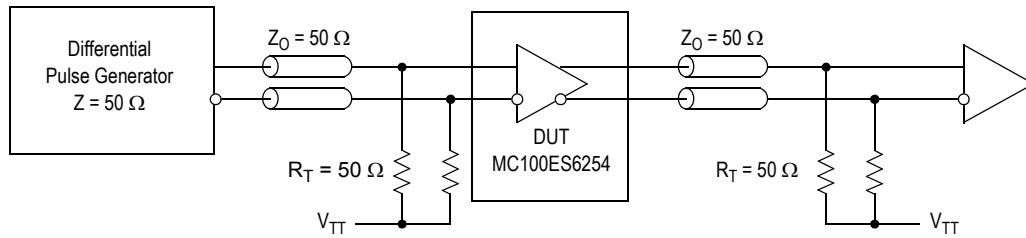
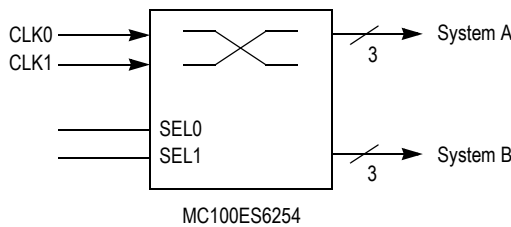

Figure 4. MC100ES6254 AC Test Reference

APPLICATIONS INFORMATION

Example Configurations

2 x 2 CLOCK SWITCH



SEL0	SEL1	Switch Configuration
0	0	CLK0 clocks systems A and system B
0	1	CLK1 clocks system A and system B
1	0	CLK0 clocks system A and CLK1 clocks system B
1	1	CLK1 clocks system B and CLK1 clocks system A

1:6 CLOCK FANOUT BUFFER

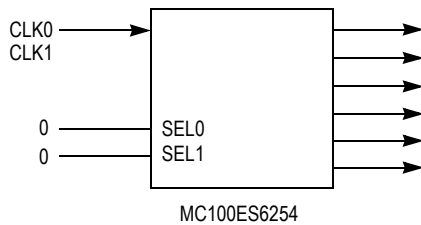

LOOPBACK DEVICE

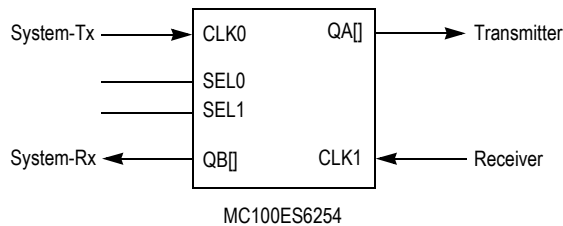

SEL0	SEL1	Switch Configuration
0	0	System loopback
0	1	Line loopback
1	0	Transmit/Receive operation
1	1	System and line loopback

Understanding the Junction Temperature Range of the MC100ES6254

To make the optimum use of high clock frequency and low skew capabilities of the MC100ES6254, the MC100ES6254 is specified, characterized and tested for the junction temperature range of $T_J = 0^\circ\text{C}$ to $+110^\circ\text{C}$. Because the exact thermal performance depends on the PCB type, design, thermal management and natural or forced air convection, the junction temperature provides an exact way to correlate the application specific conditions to the published performance data of this data sheet. The correlation of the junction temperature range to the application ambient temperature range and vice versa can be done by calculation:

$$T_J = T_A + R_{thja} \cdot P_{tot}$$

Assuming a thermal resistance (junction to ambient) of $54.4^\circ\text{C}/\text{W}$ (2s2p board, 200 ft/min airflow, refer to Table 8) and a typical power consumption of 467mW (all outputs terminated $50\ \Omega$ to V_{TT} , $V_{CC} = 3.3\ \text{V}$, frequency independent), the junction temperature of the MC100ES6254 is approximately $T_A + 24.5^\circ\text{C}$, and the minimum ambient temperature in this example case calculates to -24.5°C (the maximum ambient temperature is 85.5°C , refer to Table 8). Exceeding the minimum junction temperature specification of the MC100ES6254 does not have a significant impact on the device functionality. However, the continuous use the MC100ES6254 at high ambient temperatures requires thermal management to not exceed the specified maximum junction temperature. Refer to the Freescale application note AN1545 for a power consumption calculation guideline.

Table 8. Ambient Temperature Range ($P_{tot} = 467\ \text{mW}$)

R_{thja} (2s2p board)		$T_{A, \text{min}}^{(1)}$	$T_{A, \text{max}}$
Natural Convection	$59.0^\circ\text{C}/\text{W}$	-28°C	82°C
100 ft/min	$54.4^\circ\text{C}/\text{W}$	-25°C	85°C
200 ft/min	$52.5^\circ\text{C}/\text{W}$	-24.5°C	85.5°C
400 ft/min	$50.4^\circ\text{C}/\text{W}$	-23.5°C	86.5°C
800 ft/min	$47.8^\circ\text{C}/\text{W}$	-22°C	88°C

1. The MC100ES6254 device function is guaranteed from $T_A = -40^\circ\text{C}$ to $T_J = 110^\circ\text{C}$.

Maintaining Lowest Device Skew

The MC100ES6254 guarantees low output-to-output bank skew of 50 ps and a part-to-part skew of maximum 250 ps. To ensure low skew clock signals in the application, both outputs of any differential output pair need to be terminated identically, even if only one output is used. When fewer than all nine output pairs are used, identical termination of all output pairs within the output bank is recommended. If an entire output bank is not used, it is recommended to leave all of these outputs open and unterminated. This will reduce the device power consumption while maintaining minimum output skew.

Power Supply Bypassing

The MC100ES6254 is a mixed analog/digital product. The differential architecture of the MC100ES6254 supports low noise signal operation at high frequencies. In order to maintain its superior signal quality, all V_{CC} pins should be bypassed by high-frequency ceramic capacitors connected to GND. If the spectral frequencies of the internally generated switching noise on the supply pins cross the series resonant point of an individual bypass capacitor, its overall impedance begins to look inductive and thus increases with increasing frequency. The parallel capacitor combination shown ensures that a low impedance path to ground exists for frequencies well above the noise bandwidth.

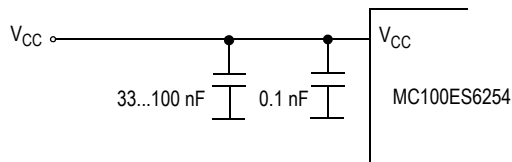
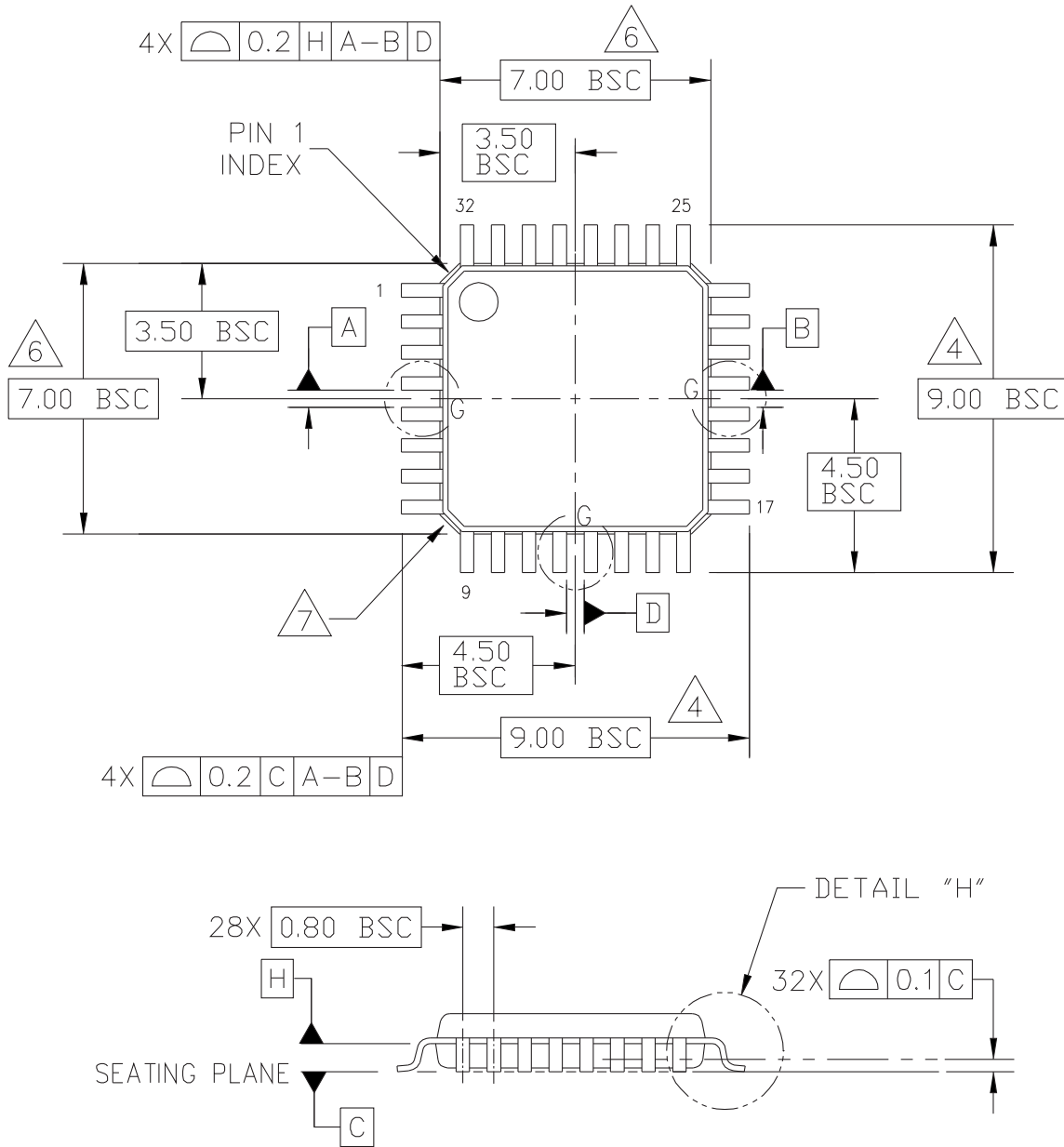

Figure 5. V_{CC} Power Supply Bypass

PACKAGE DIMENSIONS



© FREESCALE SEMICONDUCTOR, INC. ALL RIGHTS RESERVED.	MECHANICAL OUTLINE	PRINT VERSION NOT TO SCALE	
TITLE: LOW PROFILE QUAD FLAT PACK (LQFP) 32 LEAD, 0.8 PITCH (7 X 7 X 1.4)	DOCUMENT NO: 98ASH70029A	REV: C	
	CASE NUMBER: 873A-04	01 APR 2005	
	STANDARD: JEDEC MS-026 BBA		

**CASE 873A-04
ISSUE C
32-LEAD LQFP PACKAGE**

PACKAGE DIMENSIONS

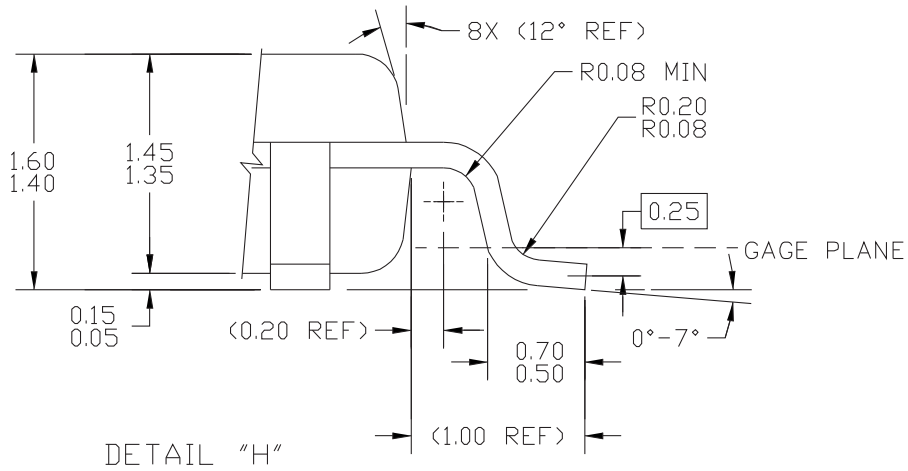
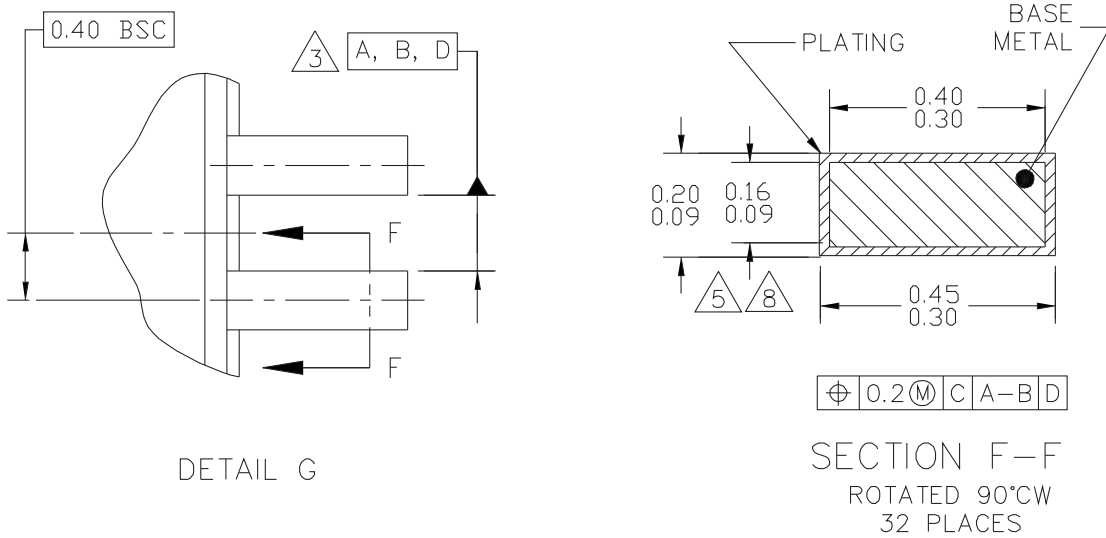

© FREESCALE SEMICONDUCTOR, INC. ALL RIGHTS RESERVED.	MECHANICAL OUTLINE	PRINT VERSION NOT TO SCALE	
TITLE: LOW PROFILE QUAD FLAT PACK (LQFP) 32 LEAD, 0.8 PITCH (7 X 7 X 1.4)	DOCUMENT NO: 98ASH70029A	REV: C	
	CASE NUMBER: 873A-04	01 APR 2005	
	STANDARD: JEDEC MS-026 BBA		

**CASE 873A-04
ISSUE C
32-LEAD LQFP PACKAGE**

PACKAGE DIMENSIONS

NOTES:

1. DIMENSIONS ARE IN MILLIMETERS.
2. INTERPRET DIMENSIONS AND TOLERANCES PER ASME Y14.5-1994.
3. DATUMS A, B, AND D TO BE DETERMINED AT DATUM PLANE H.
4. DIMENSIONS TO BE DETERMINED AT SEATING PLANE DATUM C.
5. DIMENSION DOES NOT INCLUDE DAMBAR PROTRUSION. ALLOWABLE DAMBAR PROTRUSION SHALL NOT CAUSE THE LEAD WIDTH TO EXCEED THE MAXIMUM DIMENSION BY MORE THAN 0.08 MM. DAMBAR CANNOT BE LOCATED ON THE LOWER RADIUS OR THE FOOT. MINIMUM SPACE BETWEEN PROTRUSION AND ADJACENT LEAD OR PROTRUSION: 0.07 MM.
6. DIMENSIONS DO NOT INCLUDE MOLD PROTRUSION. ALLOWABLE PROTRUSION IS 0.25 MM PER SIDE. DIMENSIONS ARE MAXIMUM PLASTIC BODY SIZE DIMENSIONS INCLUDING MOLD MISMATCH.
7. EXACT SHAPE OF EACH CORNER IS OPTIONAL.
8. THESE DIMENSIONS APPLY TO THE FLAT SECTION OF THE LEAD BETWEEN 0.1 MM AND 0.25 MM FROM THE LEAD TIP.

© FREESCALE SEMICONDUCTOR, INC. ALL RIGHTS RESERVED.	MECHANICAL OUTLINE	PRINT VERSION NOT TO SCALE	
TITLE: LOW PROFILE QUAD FLAT PACK (LQFP) 32 LEAD, 0.8 PITCH (7 X 7 X 1.4)	DOCUMENT NO: 98ASH70029A	REV: C	
	CASE NUMBER: 873A-04	01 APR 2005	
	STANDARD: JEDEC MS-026 BBA		

PAGE 3 OF 3

**CASE 873A-04
ISSUE C
32-LEAD LQFP PACKAGE**

We've Got Your Timing Solution



6024 Silver Creek Valley Road
San Jose, California 95138

Sales
800-345-7015 (inside USA)
+408-284-8200 (outside USA)
Fax: 408-284-2775
www.IDT.com/go/contactIDT

Technical Support
netcom@idt.com
+480-763-2056

DISCLAIMER Integrated Device Technology, Inc. (IDT) and its subsidiaries reserve the right to modify the products and/or specifications described herein at any time and at IDT's sole discretion. All information in this document, including descriptions of product features and performance, is subject to change without notice. Performance specifications and the operating parameters of the described products are determined in the independent state and are not guaranteed to perform the same way when installed in customer products. The information contained herein is provided without representation or warranty of any kind, whether express or implied, including, but not limited to, the suitability of IDT's products for any particular purpose, an implied warranty of merchantability, or non-infringement of the intellectual property rights of others. This document is presented only as a guide and does not convey any license under intellectual property rights of IDT or any third parties.

IDT's products are not intended for use in applications involving extreme environmental conditions or in life support systems or similar devices where the failure or malfunction of an IDT product can be reasonably expected to significantly affect the health or safety of users. Anyone using an IDT product in such a manner does so at their own risk, absent an express, written agreement by IDT.

Integrated Device Technology, IDT and the IDT logo are registered trademarks of IDT. Other trademarks and service marks used herein, including protected names, logos and designs, are the property of IDT or their respective third party owners.

Copyright 2013. All rights reserved.