



Chipsmall Limited consists of a professional team with an average of over 10 year of expertise in the distribution of electronic components. Based in Hongkong, we have already established firm and mutual-benefit business relationships with customers from,Europe,America and south Asia,supplying obsolete and hard-to-find components to meet their specific needs.

With the principle of “Quality Parts,Customers Priority,Honest Operation,and Considerate Service”,our business mainly focus on the distribution of electronic components. Line cards we deal with include Microchip,ALPS,ROHM,Xilinx,Pulse,ON,Everlight and Freescale. Main products comprise IC,Modules,Potentiometer,IC Socket,Relay,Connector.Our parts cover such applications as commercial,industrial, and automotives areas.

We are looking forward to setting up business relationship with you and hope to provide you with the best service and solution. Let us make a better world for our industry!



## Contact us

Tel: +86-755-8981 8866 Fax: +86-755-8427 6832

Email & Skype: info@chipsmall.com Web: www.chipsmall.com

Address: A1208, Overseas Decoration Building, #122 Zhenhua RD., Futian, Shenzhen, China



# MC100LVEL11

## 3.3V ECL 1:2 Differential Fanout Buffer

### Description

The MC100LVEL11 is a differential 1:2 fanout buffer. The device is functionally similar to the E111 device but with higher performance capabilities. Having within-device skews and output transition times significantly improved over the E111, the LVEL11 is ideally suited for those applications which require the ultimate in AC performance.

The differential inputs of the LVEL11 employ clamping circuitry to maintain stability under open input conditions. If the inputs are left open (pulled to  $V_{EE}$ ) the Q outputs will go LOW.

### Features

- 330 ps Propagation Delay
- 5 ps Skew Between Outputs
- High Bandwidth Output Transitions
- The 100 Series Contains Temperature Compensation
- PECL Mode Operating Range:  $V_{CC} = 3.0\text{ V}$  to  $3.8\text{ V}$  with  $V_{EE} = 0\text{ V}$
- NECL Mode Operating Range:  $V_{CC} = 0\text{ V}$  with  $V_{EE} = -3.0\text{ V}$  to  $-3.8\text{ V}$
- Internal Input Pulldown Resistors on D, Pullup and Pulldown Resistors on  $\bar{D}$
- Q Output will Default LOW with Inputs Open or at  $V_{EE}$
- These Devices are Pb-Free and are RoHS Compliant

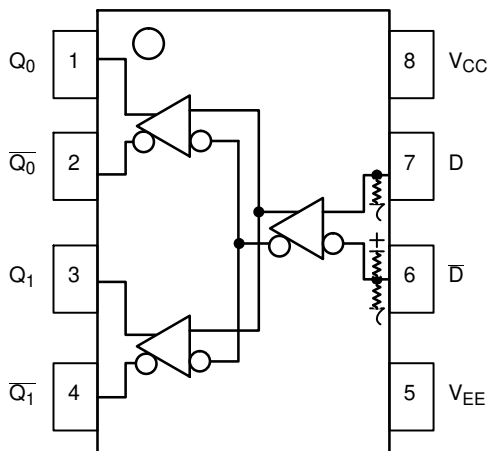

Figure 1. Logic Diagram and Pinout Assignment



ON Semiconductor®

[www.onsemi.com](http://www.onsemi.com)

### MARKING DIAGRAMS\*



SOIC-8  
D SUFFIX  
CASE 751

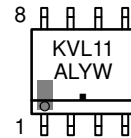

TSSOP-8  
DT SUFFIX  
CASE 948R

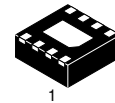
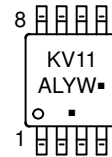

DFN8  
MN SUFFIX  
CASE 506AA

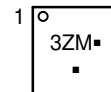

- A = Assembly Location
- L = Wafer Lot
- Y = Year
- W = Work Week
- M = Date Code
- = Pb-Free Package

(Note: Microdot may be in either location)

\*For additional marking information, refer to Application Note AND8002/D.

### ORDERING INFORMATION

See detailed ordering and shipping information in the package dimensions section on page 5 of this data sheet.

# MC100LVEL11

**Table 1. PIN DESCRIPTION**

Pin	Function
Q0, $\overline{Q0}$ ; Q1, $\overline{Q1}$	ECL Data Outputs
D, $\overline{D}$	ECL Data Inputs
V <sub>CC</sub>	Positive Supply
V <sub>EE</sub>	Negative Supply
EP	(DFN8 only) Thermal exposed pad must be connected to a sufficient thermal conduit. Electrically connect to the most negative supply (GND) or leave unconnected, floating open.

**Table 2. ATTRIBUTES**

Characteristics	Value
Internal Input Pulldown Resistor	75 k $\Omega$
Internal Input Pullup Resistor	75 k $\Omega$
ESD Protection	Human Body Model Machine Model Charge Device Model
	> 4 kV > 400 V > 2 kV
Moisture Sensitivity, Indefinite Time Out of Drypack (Note 1)	
	SOIC-8 TSSOP-8 DFN8
	Level 1 Level 3 Level 1
Flammability Rating	Oxygen Index: 28 to 34
	UL 94 V-0 @ 0.125 in
Transistor Count	63
Meets or exceeds JEDEC Spec EIA/JESD78 IC Latchup Test	

1. For additional information, see Application Note AND8003/D.

**Table 3. MAXIMUM RATINGS**

Symbol	Parameter	Condition 1	Condition 2	Rating	Units
V <sub>CC</sub>	PECL Mode Power Supply	V <sub>EE</sub> = 0 V		8 to 0	V
V <sub>EE</sub>	NECL Mode Power Supply	V <sub>CC</sub> = 0 V		-8 to 0	V
V <sub>I</sub>	PECL Mode Input Voltage NECL Mode Input Voltage	V <sub>EE</sub> = 0 V V <sub>CC</sub> = 0 V	V <sub>I</sub> ≤ V <sub>CC</sub> V <sub>I</sub> ≥ V <sub>EE</sub>	6 to 0 -6 to 0	V
I <sub>out</sub>	Output Current	Continuous Surge		50 100	mA mA
T <sub>A</sub>	Operating Temperature Range			-40 to +95	°C
T <sub>stg</sub>	Storage Temperature Range			-65 to +150	°C
$\theta_{JA}$	Thermal Resistance (Junction-to-Ambient)	0 lpfm 500 lpfm	SOIC-8 SOIC-8	190 130	°C/W °C/W
$\theta_{JC}$	Thermal Resistance (Junction-to-Case)	Standard Board	SOIC-8	41 to 44 ± 5%	°C/W
$\theta_{JA}$	Thermal Resistance (Junction-to-Ambient)	0 lpfm 500 lpfm	TSSOP-8 TSSOP-8	185 140	°C/W °C/W
$\theta_{JC}$	Thermal Resistance (Junction-to-Case)	Standard Board	TSSOP-8	41 to 44 ± 5%	°C/W
$\theta_{JA}$	Thermal Resistance (Junction-to-Ambient)	0 lpfm 500 lpfm	DFN8 DFN8	129 84	°C/W °C/W
T <sub>sol</sub>	Wave Solder	Pb-Free	<2 to 3 sec @ 260°C	265	°C
$\theta_{JC}$	Thermal Resistance (Junction-to-Case)	(Note 2)	DFN8	35 to 40	°C/W

Stresses exceeding those listed in the Maximum Ratings table may damage the device. If any of these limits are exceeded, device functionality should not be assumed, damage may occur and reliability may be affected.

2. JEDEC standard multilayer board – 2S2P (2 signal, 2 power)

# MC100LEVEL11

**Table 4. LVPECL DC CHARACTERISTICS**  $V_{CC} = 3.3\text{ V}$ ;  $V_{EE} = 0.0\text{ V}$  (Note 3)

Symbol	Characteristic	-40°C			25°C			95°C			Unit
		Min	Typ	Max	Min	Typ	Max	Min	Typ	Max	
$I_{EE}$	Power Supply Current		24	28		24	28		25	30	mA
$V_{OH}$	Output HIGH Voltage (Note 4)	2215	2295	2420	2275	2345	2420	2275	2345	2420	mV
$V_{OL}$	Output LOW Voltage (Note 4)	1470	1605	1745	1490	1595	1680	1490	1595	1680	mV
$V_{IH}$	Input HIGH Voltage (Single-Ended)	2135		2420	2135		2420	2135		2420	mV
$V_{IL}$	Input LOW Voltage (Single-Ended)	1490		1825	1490		1825	1490		1825	mV
$V_{IHCMR}$	Input HIGH Voltage Common Mode Range (Differential) (Note 8) $V_{pp} < 500\text{ mV}$ $V_{pp} \geq 500\text{ mV}$	1.2		3.1	1.1		3.1	1.1		3.1	V
		1.4		3.1	1.3		3.1	1.3		3.1	V
$I_{IH}$	Input HIGH Current			150			150			150	$\mu\text{A}$
$I_{IL}$	Input LOW Current	D	0.5		0.5			0.5			$\mu\text{A}$
		$\bar{D}$	-600		-600			-600			$\mu\text{A}$

NOTE: Device will meet the specifications after thermal equilibrium has been established when mounted in a test socket or printed circuit board with maintained transverse airflow greater than 500 lpm.

- Input and output parameters vary 1:1 with  $V_{CC}$ .  $V_{EE}$  can vary  $\pm 0.3\text{ V}$ .
- Outputs are terminated through a  $50\ \Omega$  resistor to  $V_{CC} - 2.0\text{ V}$ .
- $V_{IHCMR}$  min varies 1:1 with  $V_{EE}$ , max varies 1:1 with  $V_{CC}$ . The  $V_{IHCMR}$  range is referenced to the most positive side of the differential input signal. Normal operation is obtained if the HIGH level falls within the specified range and the peak-to-peak voltage lies between  $V_{ppmin}$  and  $1.0\text{ V}$ .

**Table 5. LVNECL DC CHARACTERISTICS**  $V_{CC} = 0.0\text{ V}$ ;  $V_{EE} = -3.3\text{ V}$  (Note 6)

Symbol	Characteristic	-40°C			25°C			95°C			Unit
		Min	Typ	Max	Min	Typ	Max	Min	Typ	Max	
$I_{EE}$	Power Supply Current		24	28		24	28		25	30	mA
$V_{OH}$	Output HIGH Voltage (Note 7)	-1085	-1005	-880	-1025	-955	-880	-1025	-955	-880	mV
$V_{OL}$	Output LOW Voltage (Note 7)	-1830	-1695	-1555	-1810	-1705	-1620	-1810	-1705	-1620	mV
$V_{IH}$	Input HIGH Voltage (Single-Ended)	-1165		-880	-1165		-880	-1165		-880	mV
$V_{IL}$	Input LOW Voltage (Single-Ended)	-1810		-1475	-1810		-1475	-1810		-1475	mV
$V_{IHCMR}$	Input HIGH Voltage Common Mode Range (Differential) (Note 8) $V_{pp} < 500\text{ mV}$ $V_{pp} \geq 500\text{ mV}$	-2.1		-0.2	-2.2		-0.2	-2.2		-0.2	V
		-1.9		-0.2	-2.0		-0.2	-2.0		-0.2	V
$I_{IH}$	Input HIGH Current			150			150			150	$\mu\text{A}$
$I_{IL}$	Input LOW Current	D	0.5		0.5			0.5			$\mu\text{A}$
		$\bar{D}$	-600		-600			-600			$\mu\text{A}$

NOTE: Device will meet the specifications after thermal equilibrium has been established when mounted in a test socket or printed circuit board with maintained transverse airflow greater than 500 lpm.

- Input and output parameters vary 1:1 with  $V_{CC}$ .  $V_{EE}$  can vary  $\pm 0.3\text{ V}$ .
- Outputs are terminated through a  $50\ \Omega$  resistor to  $V_{CC} - 2.0\text{ V}$ .
- $V_{IHCMR}$  min varies 1:1 with  $V_{EE}$ , max varies 1:1 with  $V_{CC}$ . The  $V_{IHCMR}$  range is referenced to the most positive side of the differential input signal. Normal operation is obtained if the HIGH level falls within the specified range and the peak-to-peak voltage lies between  $V_{ppmin}$  and  $1.0\text{ V}$ .

# MC100LVEL11

**Table 6. AC CHARACTERISTICS**  $V_{CC} = 3.3\text{ V}$ ;  $V_{EE} = 0.0\text{ V}$  or  $V_{CC} = 0.0\text{ V}$ ;  $V_{EE} = -3.3\text{ V}$  (Note 9)

Symbol	Characteristic	-40°C			25°C			95°C			Unit
		Min	Typ	Max	Min	Typ	Max	Min	Typ	Max	
$f_{\max}$	Maximum Toggle Frequency					1.0					GHz
$t_{PLH}$ $t_{PHL}$	Propagation Delay to Output	235		385	255	330	405	285		435	ps
$t_{SKEW}$	Within-Device Skew (Note 10) Device-to-Device (Note 11) Duty Cycle Skew (Note 12)		5 10	20 150 20		5 10	20 150 20		5 10	20 150 20	ps
$t_{JITTER}$	Random Clock Jitter (RMS)					0.6					ps
$V_{PP}$	Input Swing (Note 13)	200		1000	200		1000	200		1000	mV
$t_r$ $t_f$	Output Rise/Fall Times Q (20% – 80%)	120		320	120	220	320	120		320	ps

NOTE: Device will meet the specifications after thermal equilibrium has been established when mounted in a test socket or printed circuit board with maintained transverse airflow greater than 500 lfm.

9.  $V_{EE}$  can vary  $\pm 0.3\text{ V}$ .

10. Within-device skew defined as identical transitions on similar paths through a device.

11. Device-to-device skew for identical transitions at identical  $V_{CC}$  levels.

12. Duty cycle skew is the difference between a  $t_{PLH}$  and  $t_{PHL}$  propagation delay through a device.

13.  $V_{PP}(\min)$  is the minimum input swing for which AC parameters guaranteed. The device will function properly with input swings below 200 mV, however, AC delays may move outside of the specified range. The device has a DC gain of  $\approx 40$ .

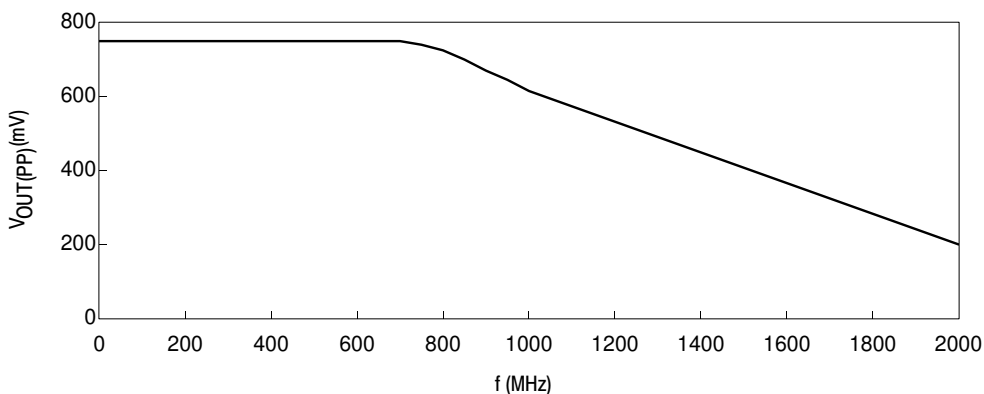

**Figure 2. Output Swing versus Frequency**

# MC100LEVEL11

## ORDERING INFORMATION

Device	Package	Shipping†
MC100LEVEL11DG	SOIC-8 (Pb-Free)	98 Units / Rail
MC100LEVEL11DR2G	SOIC-8 (Pb-Free)	2500 / Tape & Reel
MC100LEVEL11DTG	TSSOP-8 (Pb-Free)	100 Units / Rail
MC100LEVEL11DTR2G	TSSOP-8 (Pb-Free)	2500 / Tape & Reel
MC100LEVEL11MNR4G	DFN8 (Pb-Free)	1000 / Tape & Reel

†For information on tape and reel specifications, including part orientation and tape sizes, please refer to our Tape and Reel Packaging Specifications Brochure, BRD8011/D.

### Resource Reference of Application Notes

- AN1405/D** – ECL Clock Distribution Techniques
- AN1406/D** – Designing with PECL (ECL at +5.0 V)
- AN1503/D** – ECLinPS™ I/O SPiCE Modeling Kit
- AN1504/D** – Metastability and the ECLinPS Family
- AN1568/D** – Interfacing Between LVDS and ECL
- AN1672/D** – The ECL Translator Guide
- AND8001/D** – Odd Number Counters Design
- AND8002/D** – Marking and Date Codes
- AND8020/D** – Termination of ECL Logic Devices
- AND8066/D** – Interfacing with ECLinPS
- AND8090/D** – AC Characteristics of ECL Devices

# MC100LEVEL11

## PACKAGE DIMENSIONS

SOIC-8 NB  
CASE 751-07  
ISSUE AK

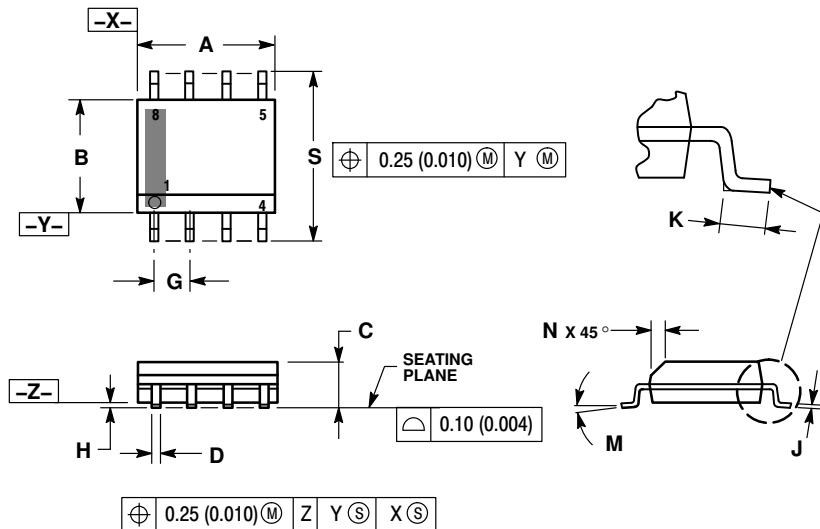

NOTES:

1. DIMENSIONING AND TOLERANCING PER ANSI Y14.5M, 1982.
2. CONTROLLING DIMENSION: MILLIMETER.
3. DIMENSION A AND B DO NOT INCLUDE MOLD PROTRUSION.
4. MAXIMUM MOLD PROTRUSION 0.15 (0.006) PER SIDE.
5. DIMENSION D DOES NOT INCLUDE DAMBAR PROTRUSION. ALLOWABLE DAMBAR PROTRUSION SHALL BE 0.127 (0.005) TOTAL IN EXCESS OF THE D DIMENSION AT MAXIMUM MATERIAL CONDITION.
6. 751-01 THRU 751-06 ARE OBSOLETE. NEW STANDARD IS 751-07.

DIM	MILLIMETERS		INCHES	
	MIN	MAX	MIN	MAX
A	4.80	5.00	0.189	0.197
B	3.80	4.00	0.150	0.157
C	1.35	1.75	0.053	0.069
D	0.33	0.51	0.013	0.020
G	1.27 BSC		0.050 BSC	
H	0.10	0.25	0.004	0.010
J	0.19	0.25	0.007	0.010
K	0.40	1.27	0.016	0.050
M	0°	8°	0°	8°
N	0.25	0.50	0.010	0.020
S	5.80	6.20	0.228	0.244

### SOLDERING FOOTPRINT\*

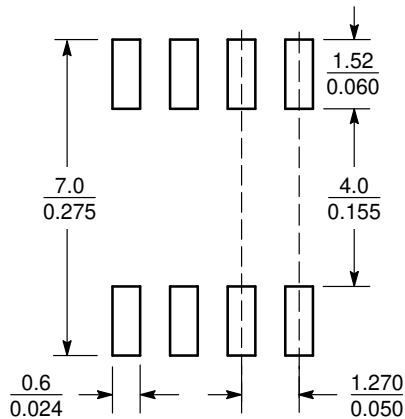

SCALE 6:1  $\left(\frac{\text{mm}}{\text{inches}}\right)$

\*For additional information on our Pb-Free strategy and soldering details, please download the ON Semiconductor Soldering and Mounting Techniques Reference Manual, SOLDERRM/D.

# MC100LVEL11

## PACKAGE DIMENSIONS

TSSOP-8  
DT SUFFIX  
CASE 948R-02  
ISSUE A

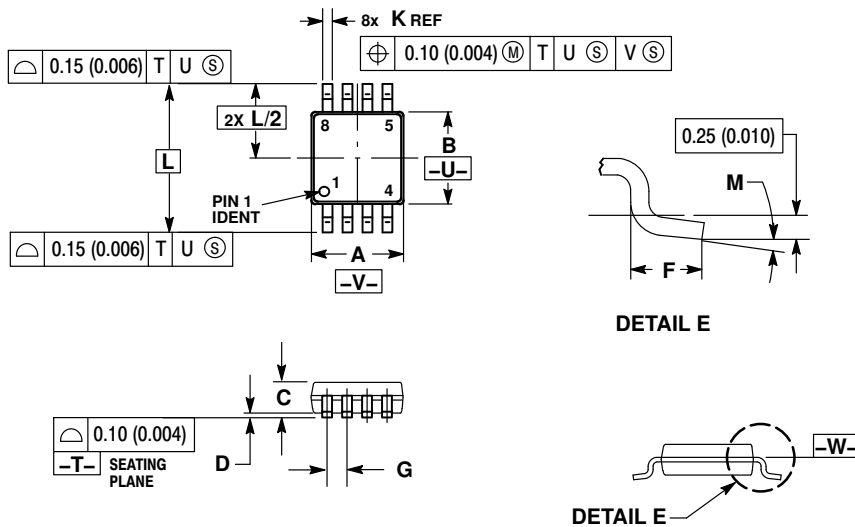

- NOTES:
1. DIMENSIONING AND TOLERANCING PER ANSI Y14.5M, 1982.
  2. CONTROLLING DIMENSION: MILLIMETER.
  3. DIMENSION A DOES NOT INCLUDE MOLD FLASH, PROTRUSIONS OR GATE BURRS. MOLD FLASH OR GATE BURRS SHALL NOT EXCEED 0.15 (0.006) PER SIDE.
  4. DIMENSION B DOES NOT INCLUDE INTERLEAD FLASH OR PROTRUSION. INTERLEAD FLASH OR PROTRUSION SHALL NOT EXCEED 0.25 (0.010) PER SIDE.
  5. TERMINAL NUMBERS ARE SHOWN FOR REFERENCE ONLY.
  6. DIMENSION A AND B ARE TO BE DETERMINED AT DATUM PLANE -W-.

DIM	MILLIMETERS		INCHES	
	MIN	MAX	MIN	MAX
A	2.90	3.10	0.114	0.122
B	2.90	3.10	0.114	0.122
C	0.80	1.10	0.031	0.043
D	0.05	0.15	0.002	0.006
F	0.40	0.70	0.016	0.028
G	0.65 BSC		0.026 BSC	
K	0.25	0.40	0.010	0.016
L	4.90 BSC		0.193 BSC	
M	0°	6°	0°	6°



# MC100LVEL11

## PACKAGE DIMENSIONS

DFN8 2x2, 0.5P  
CASE 506AA  
ISSUE E

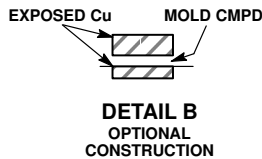
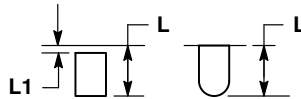
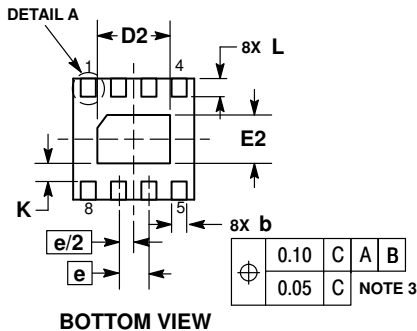
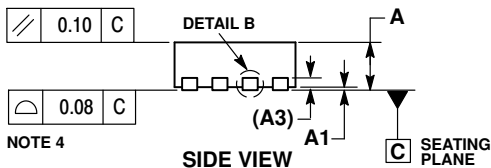
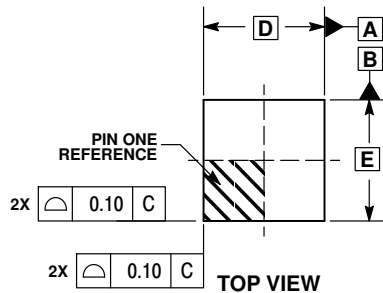

**NOTES:**

1. DIMENSIONING AND TOLERANCING PER ASME Y14.5M, 1994 .
2. CONTROLLING DIMENSION: MILLIMETERS.
3. DIMENSION b APPLIES TO PLATED TERMINAL AND IS MEASURED BETWEEN 0.15 AND 0.20 MM FROM TERMINAL TIP.
4. COPLANARITY APPLIES TO THE EXPOSED PAD AS WELL AS THE TERMINALS.

DIM	MILLIMETERS	
	MIN	MAX
A	0.80	1.00
A1	0.00	0.05
A3	0.20 REF	
b	0.20	0.30
D	2.00 BSC	
D2	1.10	1.30
E	2.00 BSC	
E2	0.70	0.90
e	0.50 BSC	
K	0.30 REF	
L	0.25	0.35
L1	---	0.10

**RECOMMENDED  
SOLDERING FOOTPRINT\***

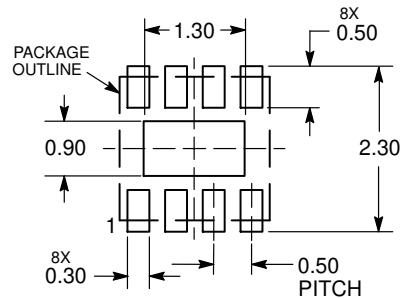

\*For additional information on our Pb-Free strategy and soldering details, please download the ON Semiconductor Soldering and Mounting Techniques Reference Manual, SOLDERRM/D.

ECLinPS Plus is a trademark of Semiconductor Components Industries, LLC.

ON Semiconductor and the  are registered trademarks of Semiconductor Components Industries, LLC (SCILLC) or its subsidiaries in the United States and/or other countries. SCILLC owns the rights to a number of patents, trademarks, copyrights, trade secrets, and other intellectual property. A listing of SCILLC's product/patent coverage may be accessed at [www.onsemi.com/site/pdf/Patent-Marking.pdf](http://www.onsemi.com/site/pdf/Patent-Marking.pdf). SCILLC reserves the right to make changes without further notice to any products herein. SCILLC makes no warranty, representation or guarantee regarding the suitability of its products for any particular purpose, nor does SCILLC assume any liability arising out of the application or use of any product or circuit, and specifically disclaims any and all liability, including without limitation special, consequential or incidental damages. "Typical" parameters which may be provided in SCILLC data sheets and/or specifications can and do vary in different applications and actual performance may vary over time. All operating parameters, including "Typicals" must be validated for each customer application by customer's technical experts. SCILLC does not convey any license under its patent rights nor the rights of others. SCILLC products are not designed, intended, or authorized for use as components in systems intended for surgical implant into the body, or other applications intended to support or sustain life, or for any other application in which the failure of the SCILLC product could create a situation where personal injury or death may occur. Should Buyer purchase or use SCILLC products for any such unintended or unauthorized application, Buyer shall indemnify and hold SCILLC and its officers, employees, subsidiaries, affiliates, and distributors harmless against all claims, costs, damages, and expenses, and reasonable attorney fees arising out of, directly or indirectly, any claim of personal injury or death associated with such unintended or unauthorized use, even if such claim alleges that SCILLC was negligent regarding the design or manufacture of the part. SCILLC is an Equal Opportunity/Affirmative Action Employer. This literature is subject to all applicable copyright laws and is not for resale in any manner.

**PUBLICATION ORDERING INFORMATION**

**LITERATURE FULFILLMENT:**  
Literature Distribution Center for ON Semiconductor  
P.O. Box 5163, Denver, Colorado 80217 USA  
**Phone:** 303-675-2175 or 800-344-3860 Toll Free USA/Canada  
**Fax:** 303-675-2176 or 800-344-3867 Toll Free USA/Canada  
**Email:** [orderlit@onsemi.com](mailto:orderlit@onsemi.com)

**N. American Technical Support:** 800-282-9855 Toll Free USA/Canada  
**Europe, Middle East and Africa Technical Support:**  
Phone: 421 33 790 2910  
**Japan Customer Focus Center**  
Phone: 81-3-5817-1050

**ON Semiconductor Website:** [www.onsemi.com](http://www.onsemi.com)  
**Order Literature:** <http://www.onsemi.com/orderlit>  
For additional information, please contact your local Sales Representative