



Chipsmall Limited consists of a professional team with an average of over 10 year of expertise in the distribution of electronic components. Based in Hongkong, we have already established firm and mutual-benefit business relationships with customers from,Europe,America and south Asia,supplying obsolete and hard-to-find components to meet their specific needs.

With the principle of “Quality Parts,Customers Priority,Honest Operation,and Considerate Service”,our business mainly focus on the distribution of electronic components. Line cards we deal with include Microchip,ALPS,ROHM,Xilinx,Pulse,ON,Everlight and Freescale. Main products comprise IC,Modules,Potentiometer,IC Socket,Relay,Connector.Our parts cover such applications as commercial,industrial, and automotives areas.

We are looking forward to setting up business relationship with you and hope to provide you with the best service and solution. Let us make a better world for our industry!



Contact us

Tel: +86-755-8981 8866 Fax: +86-755-8427 6832

Email & Skype: info@chipsmall.com Web: www.chipsmall.com

Address: A1208, Overseas Decoration Building, #122 Zhenhua RD., Futian, Shenzhen, China



MC14538B

Dual Precision Retriggerable/Resettable Monostable Multivibrator

The MC14538B is a dual, retriggerable, resettable monostable multivibrator. It may be triggered from either edge of an input pulse, and produces an accurate output pulse over a wide range of widths, the duration and accuracy of which are determined by the external timing components, C_X and R_X .

Output Pulse Width $T = R_X \cdot C_X$ (secs)

$R_X = \Omega$

$C_X = \text{Farads}$

- ≥ Unlimited Rise and Fall Time Allowed on the A Trigger Input
- ≥ Pulse Width Range = 10 μs to 10 s
- ≥ Latched Trigger Inputs
- ≥ Separate Latched Reset Inputs
- ≥ 3.0 Vdc to 18 Vdc Operational Limits
- ≥ Triggerable from Positive (A Input) or Negative-Going Edge (B-Input)
- ≥ Capable of Driving Two Low-power TTL Loads or One Low-power Schottky TTL Load Over the Rated Temperature Range
- ≥ Pin-for-pin Compatible with MC14528B and CD4528B (CD4098)
- ≥ Use the MC54/74HC4538A for Pulse Widths Less Than 10 μs with Supplies Up to 6 V.

MAXIMUM RATINGS (Voltages Referenced to V_{SS}) (Note 2.)

Symbol	Parameter	Value	Unit
V_{DD}	DC Supply Voltage Range	-0.5 to +18.0	V
V_{in}, V_{out}	Input or Output Voltage Range (DC or Transient)	-0.5 to $V_{DD} + 0.5$	V
I_{in}, I_{out}	Input or Output Current (DC or Transient) per Pin	± 10	mA
P_D	Power Dissipation, per Package (Note 3.)	500	mW
T_A	Operating Temperature Range	-55 to +125	$^{\circ}\text{C}$
T_{stg}	Storage Temperature Range	-65 to +150	$^{\circ}\text{C}$
T_L	Lead Temperature (8-Second Soldering)	260	$^{\circ}\text{C}$

2. Maximum Ratings are those values beyond which damage to the device may occur.
3. Temperature Derating:
Plastic "P and D/DW" Packages: - 7.0 mW/ $^{\circ}\text{C}$ From 65 $^{\circ}\text{C}$ To 125 $^{\circ}\text{C}$

This device contains protection circuitry to guard against damage due to high static voltages or electric fields. However, precautions must be taken to avoid applications of any voltage higher than maximum rated voltages to this high-impedance circuit. For proper operation, V_{in} and V_{out} should be constrained to the range $V_{SS} \leq (V_{in} \text{ or } V_{out}) \leq V_{DD}$.

Unused inputs must always be tied to an appropriate logic voltage level (e.g., either V_{SS} or V_{DD}). Unused outputs must be left open.



ON Semiconductor

<http://onsemi.com>

MARKING DIAGRAMS

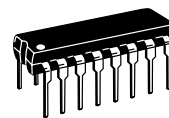

PDIP-16
P SUFFIX
CASE 648

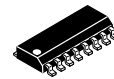
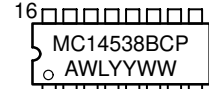

SOIC-16
D SUFFIX
CASE 751B

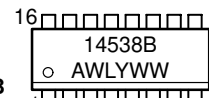

TSSOP-16
DT SUFFIX
CASE 948F

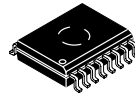
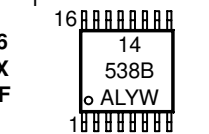

SOIC-16
DW SUFFIX
CASE 751G

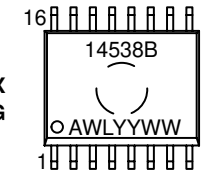

SOEIAJ-16
F SUFFIX
CASE 966



A = Assembly Location
WL, L = Wafer Lot
YY, Y = Year
WW, W = Work Week

ORDERING INFORMATION

Device	Package	Shipping
MC14538BCP	PDIP-16	2000/Box
MC14538BD	SOIC-16	48/Rail
MC14538BDR2	SOIC-16	2500/Tape & Reel
MC14538BDT	TSSOP-16	96/Rail
MC14538BDTR2	TSSOP-16	2500/Tape & Reel
MC14538BDW	SOIC-16	47/Rail
MC14538BDWR2	SOIC-16	1000/Tape & Reel
MC14538BF	SOEIAJ-16	See Note 1.
MC14538BFEL	SOEIAJ-16	See Note 1.

1. For ordering information on the EIAJ version of the SOIC packages, please contact your local ON Semiconductor representative.

MC14538B

PIN ASSIGNMENT

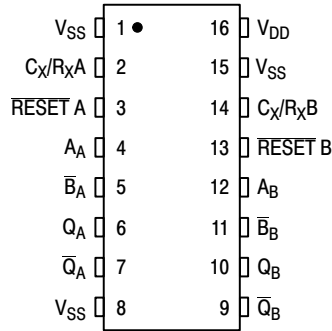

BLOCK DIAGRAM

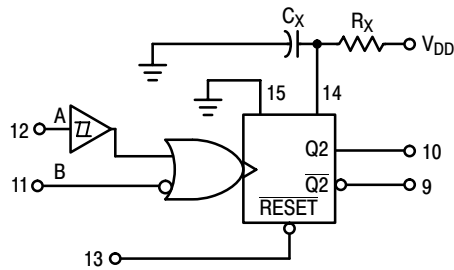
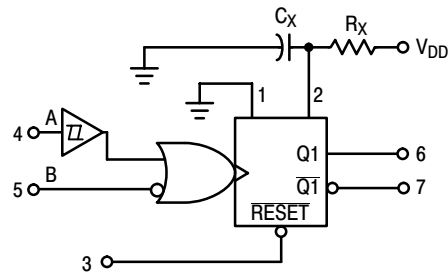

R_X AND C_X ARE EXTERNAL COMPONENTS.

V_{DD} = PIN 16

V_{SS} = PIN 8, PIN 1, PIN 15

ONE-SHOT SELECTION GUIDE

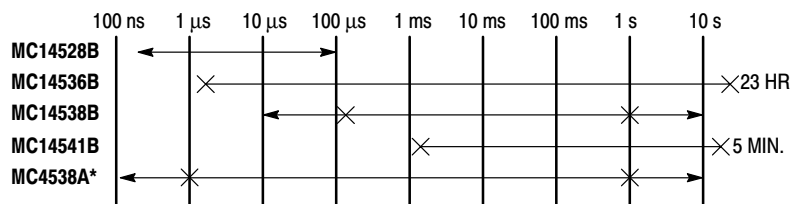

*LIMITED OPERATING VOLTAGE (2 - 6 V)

TOTAL OUTPUT PULSE WIDTH RANGE ←————→
 RECOMMENDED PULSE WIDTH RANGE ×————×

MC14538B

ELECTRICAL CHARACTERISTICS (Voltages Referenced to V_{SS})

Characteristic	Symbol	V_{DD} Vdc	-55°C		25°C			125°C		Unit
			Min	Max	Min	Typ (4.)	Max	Min	Max	
Output Voltage $V_{in} = V_{DD}$ or 0 $V_{in} = 0$ or V_{DD}	"0" Level V_{OL}	5.0	—	0.05	—	0	0.05	—	0.05	Vdc
		10	—	0.05	—	0	0.05	—	0.05	
		15	—	0.05	—	0	0.05	—	0.05	
	"1" Level V_{OH}	5.0	4.95	—	4.95	5.0	—	4.95	—	Vdc
		10	9.95	—	9.95	10	—	9.95	—	
		15	14.95	—	14.95	15	—	14.95	—	
Input Voltage "0" Level ($V_O = 4.5$ or 0.5 Vdc) ($V_O = 9.0$ or 1.0 Vdc) ($V_O = 13.5$ or 1.5 Vdc) "1" Level ($V_O = 0.5$ or 4.5 Vdc) ($V_O = 1.0$ or 9.0 Vdc) ($V_O = 1.5$ or 13.5 Vdc)	V_{IL}	5.0	—	1.5	—	2.25	1.5	—	1.5	Vdc
		10	—	3.0	—	4.50	3.0	—	3.0	
		15	—	4.0	—	6.75	4.0	—	4.0	
	V_{IH}	5.0	3.5	—	3.5	2.75	—	3.5	—	Vdc
		10	7.0	—	7.0	5.50	—	7.0	—	
		15	11	—	11	8.25	—	11	—	
Output Drive Current Source ($V_{OH} = 2.5$ Vdc) ($V_{OH} = 4.6$ Vdc) ($V_{OH} = 9.5$ Vdc) ($V_{OH} = 13.5$ Vdc) Sink ($V_{OL} = 0.4$ Vdc) ($V_{OL} = 0.5$ Vdc) ($V_{OL} = 1.5$ Vdc)	I_{OH}	5.0	-3.0	—	-2.4	-4.2	—	-1.7	—	mAdc
		5.0	-0.64	—	-0.51	-0.88	—	-0.36	—	
		10	-1.6	—	-1.3	-2.25	—	-0.9	—	
		15	-4.2	—	-3.4	-8.8	—	-2.4	—	
	I_{OL}	5.0	0.64	—	0.51	0.88	—	0.36	—	mAdc
		10	1.6	—	1.3	2.25	—	0.9	—	
15		4.2	—	3.4	8.8	—	2.4	—		
Input Current, Pin 2 or 14	I_{in}	15	—	± 0.05	—	± 0.00001	± 0.05	—	± 0.5	μ Adc
Input Current, Other Inputs	I_{in}	15	—	± 0.1	—	± 0.00001	± 0.1	—	± 1.0	μ Adc
Input Capacitance, Pin 2 or 14	C_{in}	—	—	—	—	25	—	—	—	pF
Input Capacitance, Other Inputs ($V_{in} = 0$)	C_{in}	—	—	—	—	5.0	7.5	—	—	pF
Quiescent Current (Per Package) Q = Low, \bar{Q} = High	I_{DD}	5.0	—	5.0	—	0.005	5.0	—	150	μ Adc
		10	—	10	—	0.010	10	—	300	
		15	—	20	—	0.015	20	—	600	
Quiescent Current, Active State (Both) (Per Package) Q = High, \bar{Q} = Low	I_{DD}	5.0	—	2.0	—	0.04	0.20	—	2.0	mAdc
		10	—	2.0	—	0.08	0.45	—	2.0	
		15	—	2.0	—	0.13	0.70	—	2.0	
Total Supply Current at an external load capacitance (C_L) and at external timing network (R_X, C_X) (5.)	I_T	5.0 10	$I_T = (3.5 \times 10^{-2}) R_X C_X f + 4 C_X f + 1 \times 10^{-5} C_L f$ $I_T = (8.0 \times 10^{-2}) R_X C_X f + 9 C_X f + 2 \times 10^{-5} C_L f$ $I_T = (1.25 \times 10^{-1}) R_X C_X f + 12 C_X f + 3 \times 10^{-5} C_L f$ where: I_T in μ A (one monostable switching only), C_X in μ F, C_L in pF, R_X in k ohms, and f in Hz is the input frequency.							μ Adc

4. Data labelled "Typ" is not to be used for design purposes but is intended as an indication of the IC's potential performance.

5. The formulas given are for the typical characteristics only at 25°C.

MC14538B

SWITCHING CHARACTERISTICS (6.) ($C_L = 50 \text{ pF}$, $T_A = 25^\circ\text{C}$)

Characteristic	Symbol	V_{DD} Vdc	All Types			Unit
			Min	Typ (7.)	Max	
Output Rise Time $t_{TLH} = (1.35 \text{ ns/pF}) C_L + 33 \text{ ns}$ $t_{TLH} = (0.60 \text{ ns/pF}) C_L + 20 \text{ ns}$ $t_{TLH} = (0.40 \text{ ns/pF}) C_L + 20 \text{ ns}$	t_{TLH}	5.0 10 15	— — —	100 50 40	200 100 80	ns
Output Fall Time $t_{THL} = (1.35 \text{ ns/pF}) C_L + 33 \text{ ns}$ $t_{THL} = (0.60 \text{ ns/pF}) C_L + 20 \text{ ns}$ $t_{THL} = (0.40 \text{ ns/pF}) C_L + 20 \text{ ns}$	t_{THL}	5.0 10 15	— — —	100 50 40	200 100 80	ns
Propagation Delay Time A or B to Q or \bar{Q} $t_{PLH}, t_{PHL} = (0.90 \text{ ns/pF}) C_L + 255 \text{ ns}$ $t_{PLH}, t_{PHL} = (0.36 \text{ ns/pF}) C_L + 132 \text{ ns}$ $t_{PLH}, t_{PHL} = (0.26 \text{ ns/pF}) C_L + 87 \text{ ns}$ Reset to Q or \bar{Q} $t_{PLH}, t_{PHL} = (0.90 \text{ ns/pF}) C_L + 205 \text{ ns}$ $t_{PLH}, t_{PHL} = (0.36 \text{ ns/pF}) C_L + 107 \text{ ns}$ $t_{PLH}, t_{PHL} = (0.26 \text{ ns/pF}) C_L + 82 \text{ ns}$	$t_{PLH},$ t_{PHL}	5.0 10 15	— — —	300 150 100	600 300 220	ns
Input Rise and Fall Times Reset B Input A Input	t_r, t_f	5 10 15	— — —	— — —	15 5 4	μs
Input Pulse Width A, B, or Reset	$t_{WH},$ t_{WL}	5.0 10 15	170 90 80	85 45 40	— — —	ns
Retrigger Time	t_{rr}	5.0 10 15	0 0 0	— — —	— — —	ns
Output Pulse Width — Q or \bar{Q} Refer to Figures 8 and 9 $C_X = 0.002 \mu\text{F}$, $R_X = 100 \text{ k}\Omega$ $C_X = 0.1 \mu\text{F}$, $R_X = 100 \text{ k}\Omega$ $C_X = 10 \mu\text{F}$, $R_X = 100 \text{ k}\Omega$	T	5.0 10 15	198 200 202	210 212 214	230 232 234	μs
		5.0 10 15	9.3 9.4 9.5	9.86 10 10.14	10.5 10.6 10.7	ms
		5.0 10 15	0.91 0.92 0.93	0.965 0.98 0.99	1.03 1.04 1.06	s
Pulse Width Match between circuits in the same package. $C_X = 0.1 \mu\text{F}$, $R_X = 100 \text{ k}\Omega$	100 [[$(T_1 - T_2)/T_1$]]	5.0 10 15	— — —	± 1.0 ± 1.0 ± 1.0	± 5.0 ± 5.0 ± 5.0	%

6. The formulas given are for the typical characteristics only at 25°C.

7. Data labelled "Typ" is not to be used for design purposes but is intended as an indication of the IC's potential performance.

MC14538B

OPERATING CONDITIONS

External Timing Resistance	R_X	—	5.0	—	(8.)	$k\Omega$
External Timing Capacitance	C_X	—	0	—	No Limit (9.)	μF

8. The maximum usable resistance R_X is a function of the leakage of the capacitor C_X , leakage of the MC14538B, and leakage due to board layout and surface resistance. Susceptibility to externally induced noise signals may occur for $R_X > 1\text{ M}\Omega$.
9. If $C_X > 15\ \mu F$, use discharge protection diode per Fig. 11.

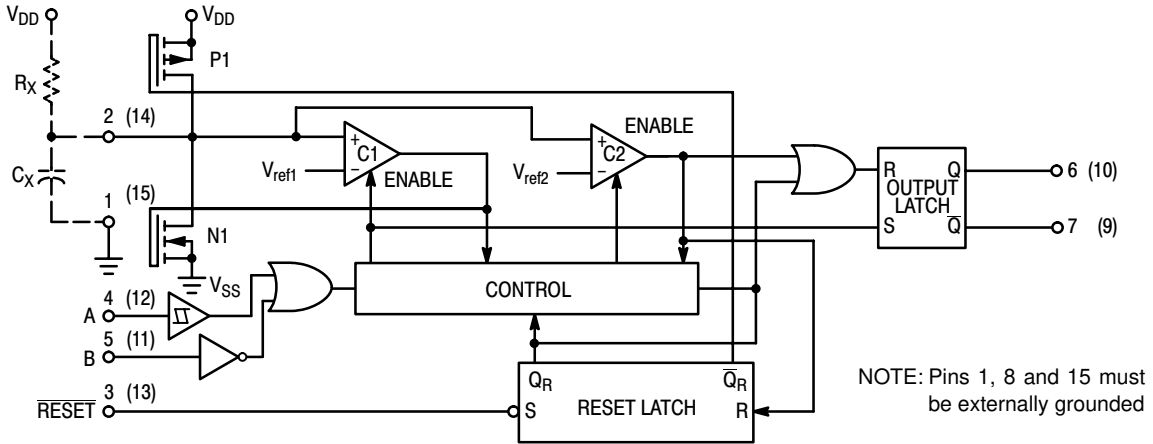

Figure 1. Logic Diagram
(1/2 of Device Shown)

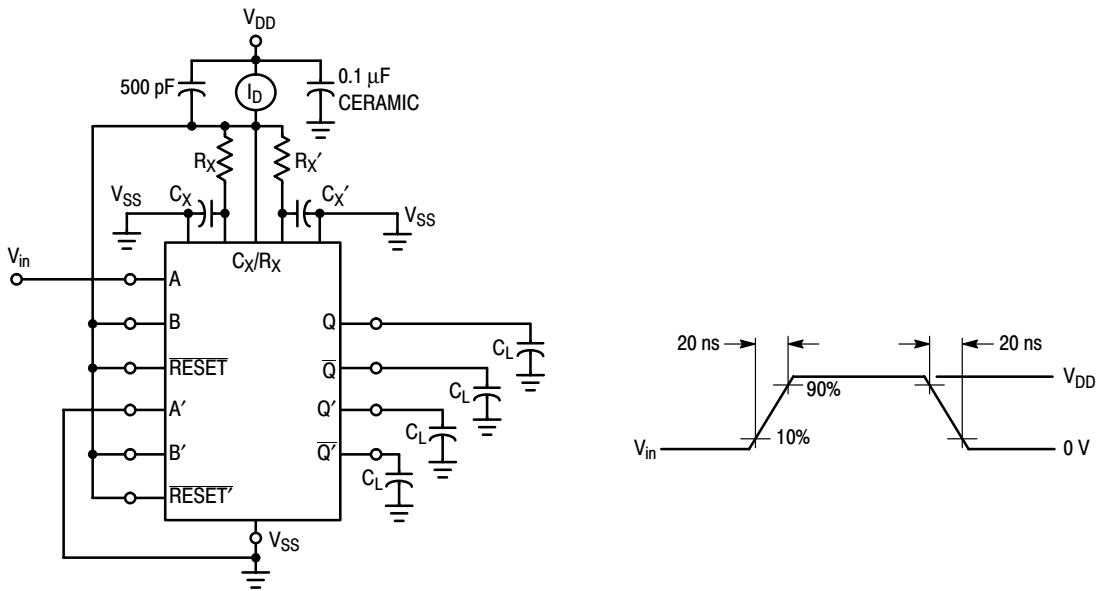
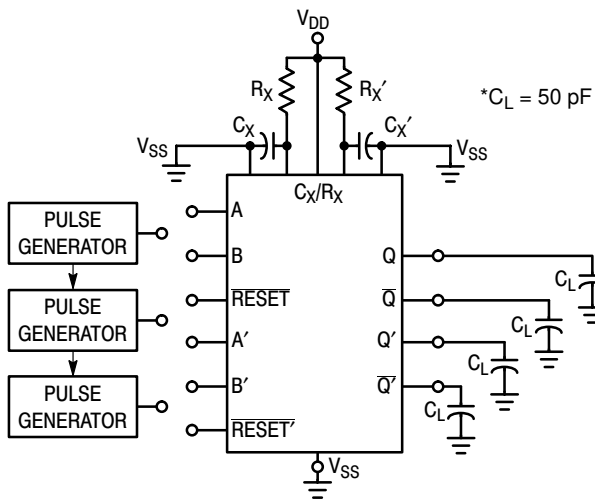

Figure 2. Power Dissipation Test Circuit and Waveforms

MC14538B



INPUT CONNECTIONS

Characteristics	Reset	A	B
t_{PLH} , t_{PHL} , t_{TLH} , t_{THL} , T , t_{WH} , t_{WL}	V_{DD}	PG1	V_{DD}
t_{PLH} , t_{PHL} , t_{TLH} , t_{THL} , T , t_{WH} , t_{WL}	V_{DD}	V_{SS}	PG2
$t_{PLH(R)}$, $t_{PHL(R)}$, t_{WH} , t_{WL}	PG3	PG1	PG2

*Includes capacitance of probes, wiring, and fixture parasitic.

NOTE: Switching test waveforms for PG1, PG2, PG3 are shown in Figure 4.

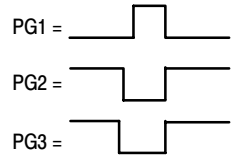

Figure 3. Switching Test Circuit

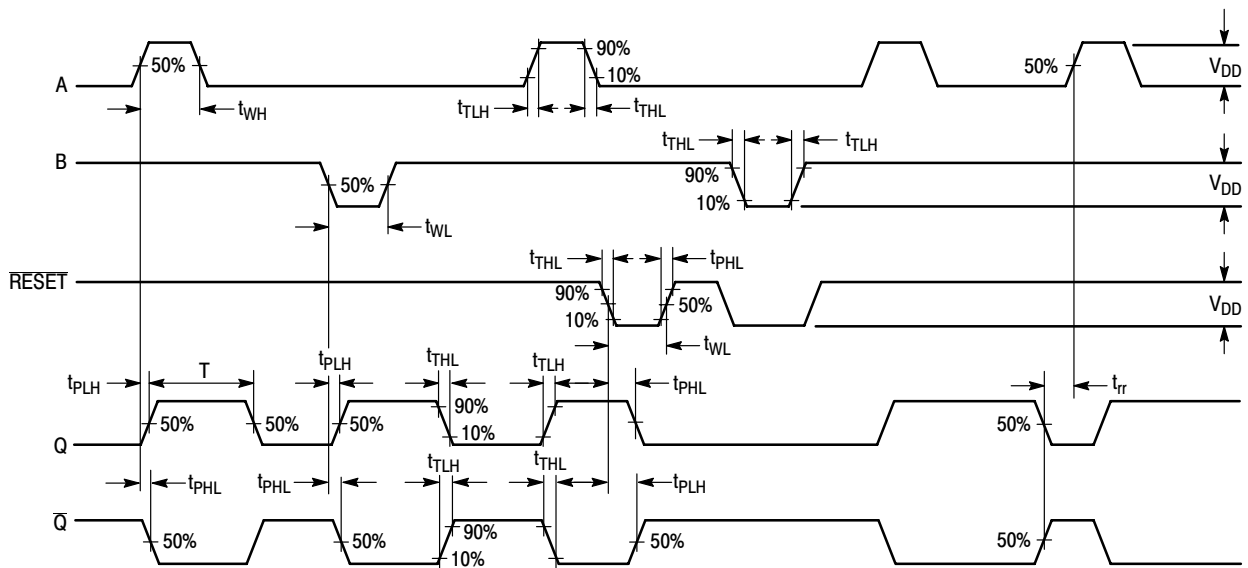

Figure 4. Switching Test Waveforms

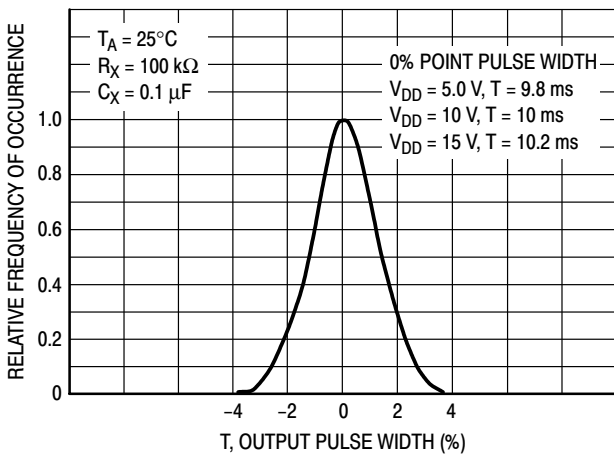

Figure 5. Typical Normalized Distribution of Units for Output Pulse Width

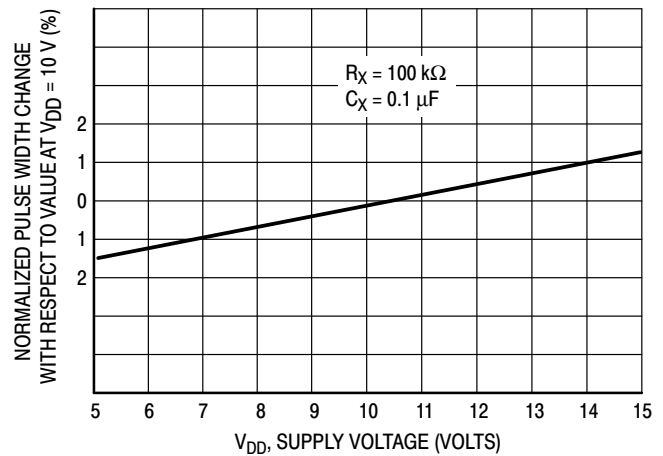

Figure 6. Typical Pulse Width Variation as a Function of Supply Voltage V_{DD}

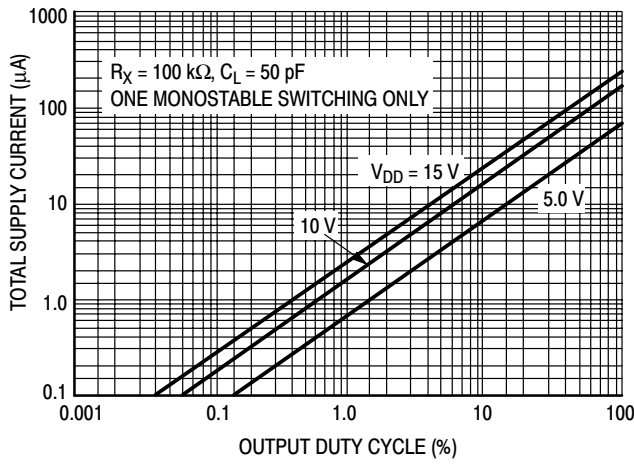

Figure 7. Typical Total Supply Current versus Output Duty Cycle

FUNCTION TABLE

Inputs			Outputs	
Reset	A	B	Q	\bar{Q}
H		H		
H	L			
H		L	Not Triggered	Not Triggered
H	H		Not Triggered	Not Triggered
H	L, H,	H	Not Triggered	Not Triggered
H	L	L, H,	Not Triggered	Not Triggered
L	X	X	L	H
	X	X	Not Triggered	Not Triggered

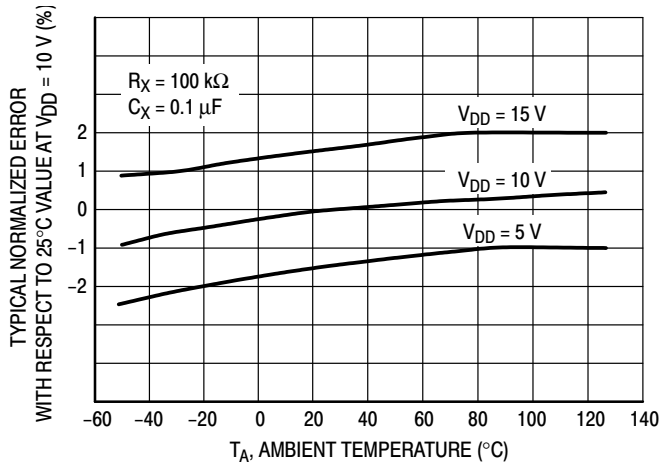

Figure 8. Typical Error of Pulse Width Equation versus Temperature

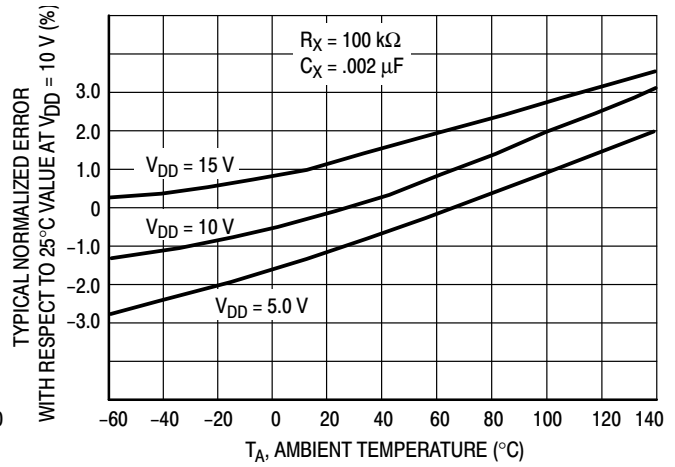

Figure 9. Typical Error of Pulse Width Equation versus Temperature

THEORY OF OPERATION

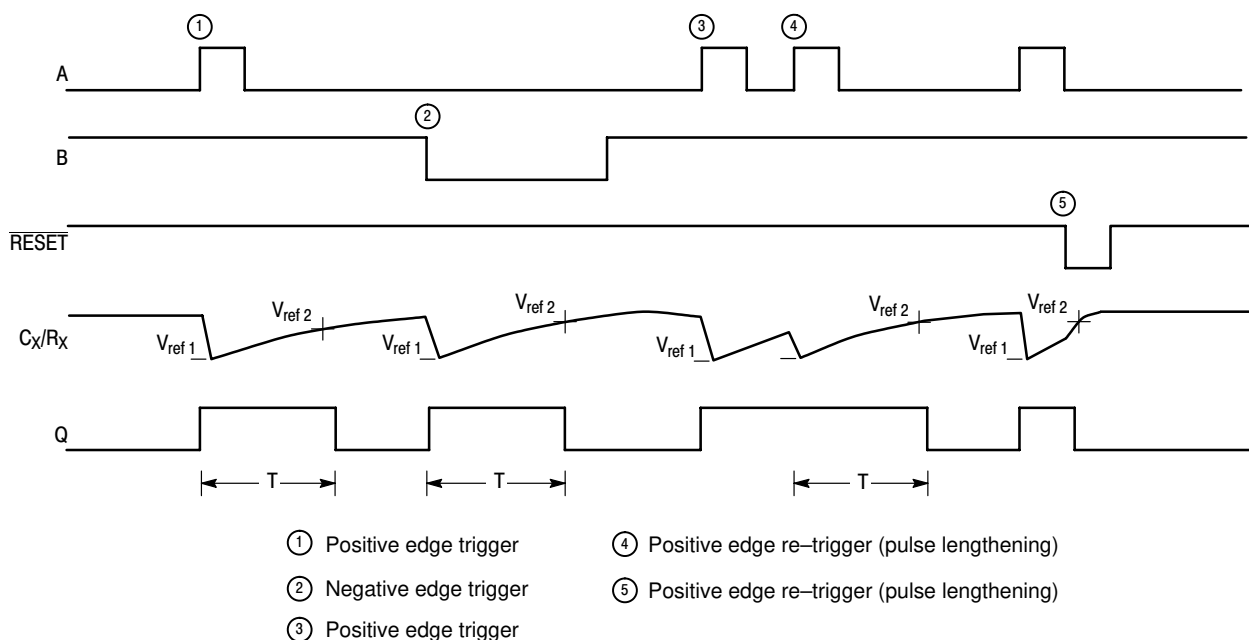

Figure 10. Timing Operation

TRIGGER OPERATION

The block diagram of the MC14538B is shown in Figure 1, with circuit operation following.

As shown in Figure 1 and 10, before an input trigger occurs, the monostable is in the quiescent state with the Q output low, and the timing capacitor C_X completely charged to V_{DD} . When the trigger input A goes from V_{SS} to V_{DD} (while inputs B and $\overline{\text{Reset}}$ are held to V_{DD}) a valid trigger is recognized, which turns on comparator C1 and N-channel transistor N1 ①. At the same time the output latch is set. With transistor N1 on, the capacitor C_X rapidly discharges toward V_{SS} until V_{ref1} is reached. At this point the output of comparator C1 changes state and transistor N1 turns off. Comparator C1 then turns off while at the same time comparator C2 turns on. With transistor N1 off, the capacitor C_X begins to charge through the timing resistor, R_X , toward V_{DD} . When the voltage across C_X equals V_{ref2} , comparator C2 changes state, causing the output latch to reset (Q goes low) while at the same time disabling comparator C2 ②. This ends at the timing cycle with the monostable in the quiescent state, waiting for the next trigger.

In the quiescent state, C_X is fully charged to V_{DD} causing the current through resistor R_X to be zero. Both comparators are “off” with total device current due only to reverse junction leakages. An added feature of the MC14538B is that the output latch is set via the input trigger without regard to the capacitor voltage. Thus, propagation delay from trigger to Q is independent of the value of C_X , R_X , or the duty cycle of the input waveform.

RETRIGGER OPERATION

The MC14538B is retriggered if a valid trigger occurs ③ followed by another valid trigger ④ before the Q output has returned to the quiescent (zero) state. Any retrigger, after the timing node voltage at pin 2 or 14 has begun to rise from V_{ref1} , but has not yet reached V_{ref2} , will cause an increase in output pulse width T. When a valid retrigger is initiated ④, the voltage at C_X/R_X will again drop to V_{ref1} before progressing along the RC charging curve toward V_{DD} . The Q output will remain high until time T, after the last valid retrigger.

RESET OPERATION

The MC14538B may be reset during the generation of the output pulse. In the reset mode of operation, an input pulse on $\overline{\text{Reset}}$ sets the reset latch and causes the capacitor to be fast charged to V_{DD} by turning on transistor P1 ⑤. When the voltage on the capacitor reaches V_{ref2} , the reset latch will clear, and will then be ready to accept another pulse. If the $\overline{\text{Reset}}$ input is held low, any trigger inputs that occur will be inhibited and the Q and \overline{Q} outputs of the output latch will not change. Since the Q output is reset when an input low level is detected on the $\overline{\text{Reset}}$ input, the output pulse T can be made significantly shorter than the minimum pulse width specification.

POWER-DOWN CONSIDERATIONS

Large capacitance values can cause problems due to the large amount of energy stored. When a system containing

MC14538B

the MC14538B is powered down, the capacitor voltage may discharge from V_{DD} through the standard protection diodes at pin 2 or 14. Current through the protection diodes should be limited to 10 mA and therefore the discharge time of the V_{DD} supply must not be faster than $(V_{DD}) \cdot (C)/(10 \text{ mA})$. For example, if $V_{DD} = 10 \text{ V}$ and $C_X = 10 \mu\text{F}$, the V_{DD} supply should discharge no faster than $(10 \text{ V}) \times (10 \mu\text{F}) / (10 \text{ mA}) = 10 \text{ ms}$. This is normally not a problem since power supplies are heavily filtered and cannot discharge at this rate.

When a more rapid decrease of V_{DD} to zero volts occurs, the MC14538B can sustain damage. To avoid this possibility use an external clamping diode, D_X , connected as shown in Fig. 11.

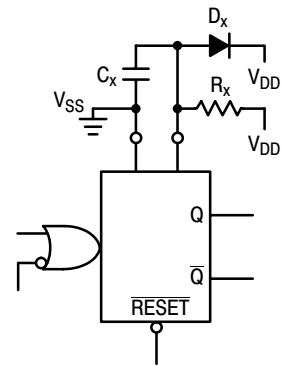

Figure 11. Use of a Diode to Limit Power Down Current Surge

TYPICAL APPLICATIONS

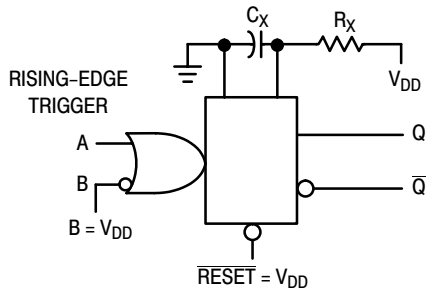

Figure 12. Retriggerable Monostables Circuitry

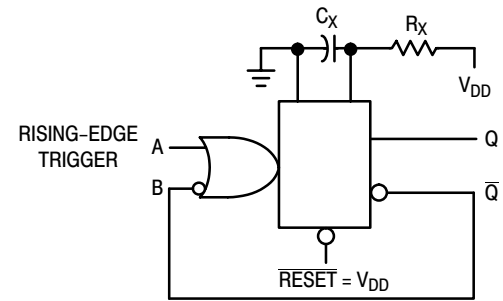
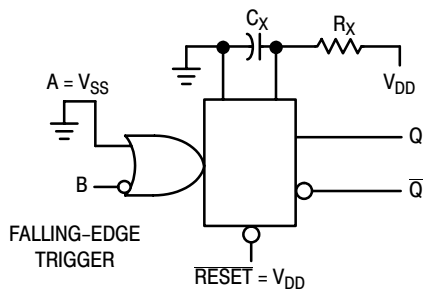

Figure 13. Non-Retriggerable Monostables Circuitry

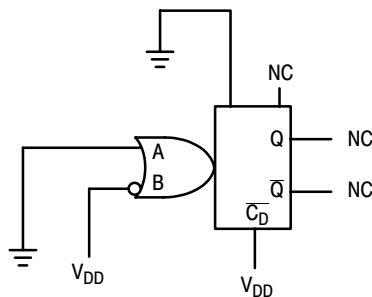
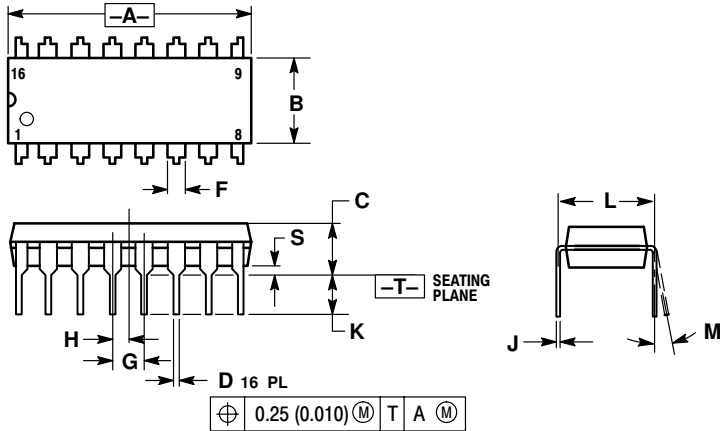

Figure 14. Connection of Unused Sections

MC14538B

PACKAGE DIMENSIONS

PDIP-16
P SUFFIX
 PLASTIC DIP PACKAGE
 CASE 648-08
 ISSUE R



NOTES:

1. DIMENSIONING AND TOLERANCING PER ANSI Y14.5M, 1982.
2. CONTROLLING DIMENSION: INCH.
3. DIMENSION L TO CENTER OF LEADS WHEN FORMED PARALLEL.
4. DIMENSION B DOES NOT INCLUDE MOLD FLASH.
5. ROUNDED CORNERS OPTIONAL.

DIM	INCHES		MILLIMETERS	
	MIN	MAX	MIN	MAX
A	0.740	0.770	18.80	19.55
B	0.250	0.270	6.35	6.85
C	0.145	0.175	3.69	4.44
D	0.015	0.021	0.39	0.53
F	0.040	0.70	1.02	1.77
G	0.100 BSC		2.54 BSC	
H	0.050 BSC		1.27 BSC	
J	0.008	0.015	0.21	0.38
K	0.110	0.130	2.80	3.30
L	0.295	0.305	7.50	7.74
M	0°	10°	0°	10°
S	0.020	0.040	0.51	1.01

SOIC-16
D SUFFIX
 PLASTIC SOIC PACKAGE
 CASE 751B-05
 ISSUE J

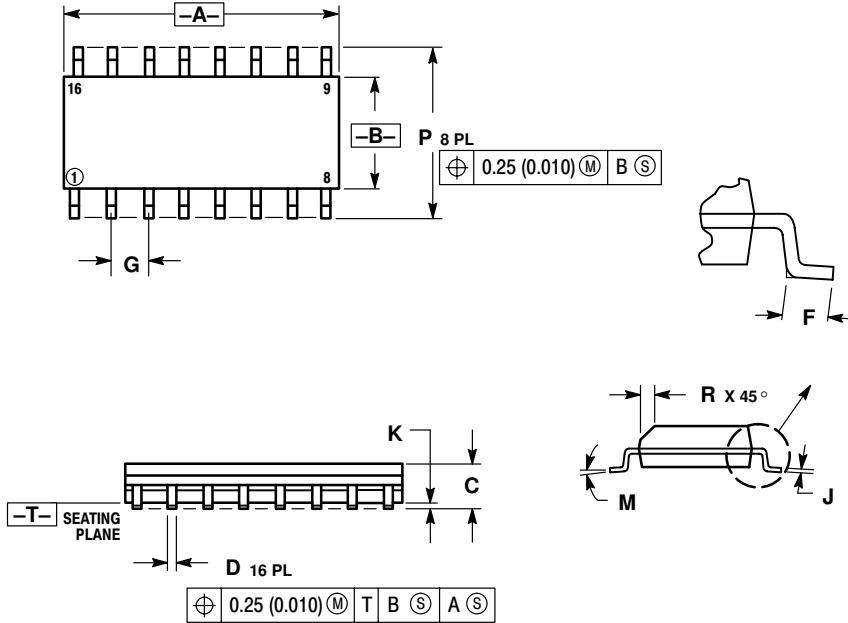

NOTES:

1. DIMENSIONING AND TOLERANCING PER ANSI Y14.5M, 1982.
2. CONTROLLING DIMENSION: MILLIMETER.
3. DIMENSIONS A AND B DO NOT INCLUDE MOLD PROTRUSION.
4. MAXIMUM MOLD PROTRUSION 0.15 (0.006) PER SIDE.
5. DIMENSION D DOES NOT INCLUDE DAMBAR PROTRUSION. ALLOWABLE DAMBAR PROTRUSION SHALL BE 0.127 (0.005) TOTAL IN EXCESS OF THE D DIMENSION AT MAXIMUM MATERIAL CONDITION.

DIM	MILLIMETERS		INCHES	
	MIN	MAX	MIN	MAX
A	9.80	10.00	0.386	0.393
B	3.80	4.00	0.150	0.157
C	1.35	1.75	0.054	0.068
D	0.35	0.49	0.014	0.019
F	0.40	1.25	0.016	0.049
G	1.27 BSC		0.050 BSC	
J	0.19	0.25	0.008	0.009
K	0.10	0.25	0.004	0.009
M	0°	7°	0°	7°
P	5.80	6.20	0.229	0.244
R	0.25	0.50	0.010	0.019

MC14538B

PACKAGE DIMENSIONS

SOIC-16
DW SUFFIX
PLASTIC SOIC PACKAGE
CASE 751G-03
ISSUE B

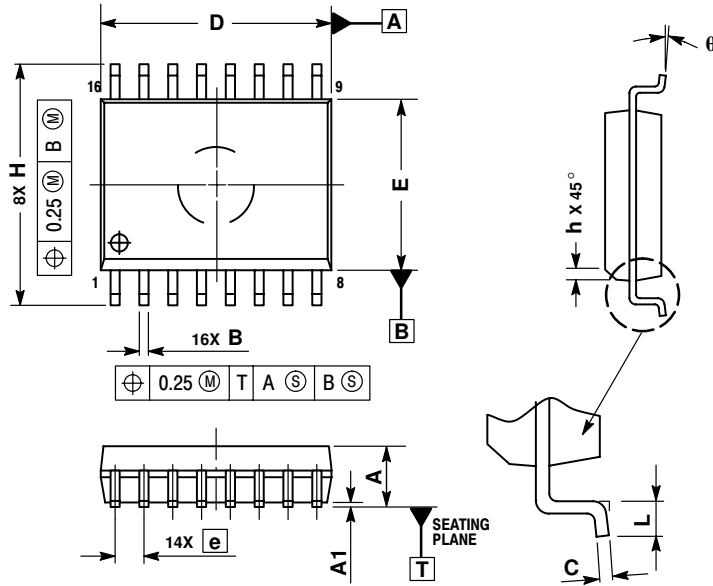

NOTES:

1. DIMENSIONS ARE IN MILLIMETERS.
2. INTERPRET DIMENSIONS AND TOLERANCES PER ASME Y14.5M, 1994.
3. DIMENSIONS D AND E DO NOT INCLUDE MOLD PROTRUSION.
4. MAXIMUM MOLD PROTRUSION 0.15 PER SIDE.
5. DIMENSION B DOES NOT INCLUDE DAMBAR PROTRUSION. ALLOWABLE DAMBAR PROTRUSION SHALL BE 0.13 TOTAL IN EXCESS OF THE B DIMENSION AT MAXIMUM MATERIAL CONDITION.

DIM	MILLIMETERS	
	MIN	MAX
A	2.35	2.65
A1	0.10	0.25
B	0.35	0.49
C	0.23	0.32
D	10.15	10.45
E	7.40	7.60
e	1.27 BSC	
H	10.05	10.55
h	0.25	0.75
L	0.50	0.90
θ	0°	7°

TSSOP-16
DT SUFFIX
PLASTIC TSSOP PACKAGE
CASE 948F-01
ISSUE O

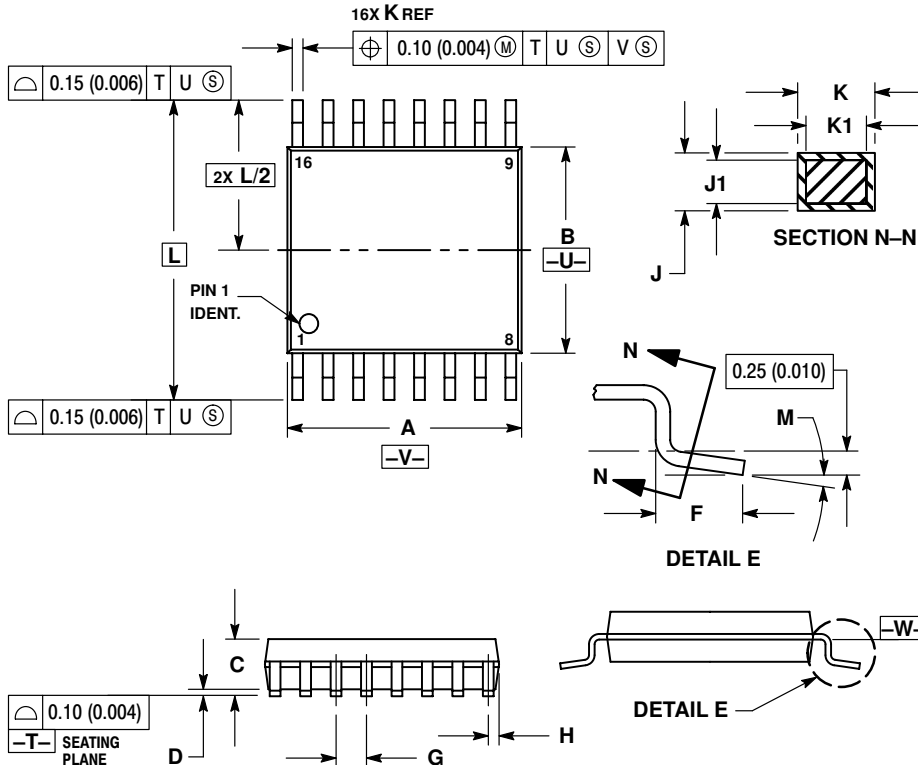

NOTES:

1. DIMENSIONING AND TOLERANCING PER ANSI Y14.5M, 1982.
2. CONTROLLING DIMENSION: MILLIMETER.
3. DIMENSION A DOES NOT INCLUDE MOLD FLASH, PROTRUSIONS OR GATE BURRS. MOLD FLASH OR GATE BURRS SHALL NOT EXCEED 0.15 (0.006) PER SIDE.
4. DIMENSION B DOES NOT INCLUDE INTERLEAD FLASH OR PROTRUSION. INTERLEAD FLASH OR PROTRUSION SHALL NOT EXCEED 0.25 (0.010) PER SIDE.
5. DIMENSION K DOES NOT INCLUDE DAMBAR PROTRUSION. ALLOWABLE DAMBAR PROTRUSION SHALL BE 0.08 (0.003) TOTAL IN EXCESS OF THE K DIMENSION AT MAXIMUM MATERIAL CONDITION.
6. TERMINAL NUMBERS ARE SHOWN FOR REFERENCE ONLY.
7. DIMENSION A AND B ARE TO BE DETERMINED AT DATUM PLANE -W-.

DIM	MILLIMETERS		INCHES	
	MIN	MAX	MIN	MAX
A	4.90	5.10	0.193	0.200
B	4.30	4.50	0.169	0.177
C	---	1.20	---	0.047
D	0.05	0.15	0.002	0.006
F	0.50	0.75	0.020	0.030
G	0.65 BSC		0.026 BSC	
H	0.18	0.28	0.007	0.011
J	0.09	0.20	0.004	0.008
J1	0.09	0.16	0.004	0.006
K	0.19	0.30	0.007	0.012
K1	0.19	0.25	0.007	0.010
L	6.40 BSC		0.252 BSC	
M	0°	8°	0°	8°

MC14538B

PACKAGE DIMENSIONS

SOEIAJ-16 F SUFFIX PLASTIC EIAJ SOIC PACKAGE CASE 966-01 ISSUE O

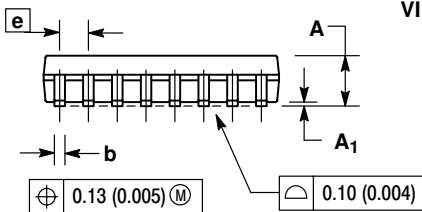
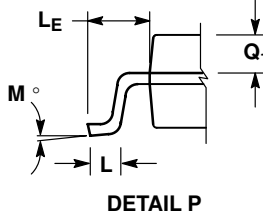
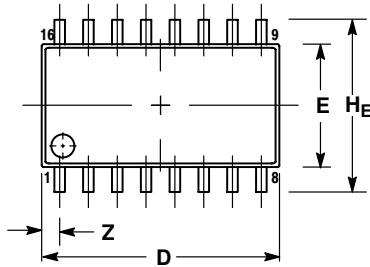

NOTES:

- DIMENSIONING AND TOLERANCING PER ANSI Y14.5M, 1982.
- CONTROLLING DIMENSION: MILLIMETER.
- DIMENSIONS D AND E DO NOT INCLUDE MOLD FLASH OR PROTRUSIONS AND ARE MEASURED AT THE PARTING LINE. MOLD FLASH OR PROTRUSIONS SHALL NOT EXCEED 0.15 (0.006) PER SIDE.
- TERMINAL NUMBERS ARE SHOWN FOR REFERENCE ONLY.
- THE LEAD WIDTH DIMENSION (b) DOES NOT INCLUDE DAMBAR PROTRUSION. ALLOWABLE DAMBAR PROTRUSION SHALL BE 0.08 (0.003) TOTAL IN EXCESS OF THE LEAD WIDTH DIMENSION AT MAXIMUM MATERIAL CONDITION. DAMBAR CANNOT BE LOCATED ON THE LOWER RADIUS OR THE FOOT. MINIMUM SPACE BETWEEN PROTRUSIONS AND ADJACENT LEAD TO BE 0.46 (0.018).

DIM	MILLIMETERS		INCHES	
	MIN	MAX	MIN	MAX
A	---	2.05	---	0.081
A ₁	0.05	0.20	0.002	0.008
b	0.35	0.50	0.014	0.020
c	0.18	0.27	0.007	0.011
D	9.90	10.50	0.390	0.413
E	5.10	5.45	0.201	0.215
e	1.27 BSC		0.050 BSC	
H _E	7.40	8.20	0.291	0.323
L	0.50	0.85	0.020	0.033
L _E	1.10	1.50	0.043	0.059
M	0°	10°	0°	10°
Q ₁	0.70	0.90	0.028	0.035
Z	---	0.78	---	0.031

ECLinPS, ECLinPS Lite and ECLinPS Plus are trademarks of Semiconductor Components Industries, LLC.

ON Semiconductor and  are trademarks of Semiconductor Components Industries, LLC (SCILLC). SCILLC reserves the right to make changes without further notice to any products herein. SCILLC makes no warranty, representation or guarantee regarding the suitability of its products for any particular purpose, nor does SCILLC assume any liability arising out of the application or use of any product or circuit, and specifically disclaims any and all liability, including without limitation special, consequential or incidental damages. "Typical" parameters which may be provided in SCILLC data sheets and/or specifications can and do vary in different applications and actual performance may vary over time. All operating parameters, including "Typicals" must be validated for each customer application by customer's technical experts. SCILLC does not convey any license under its patent rights nor the rights of others. SCILLC products are not designed, intended, or authorized for use as components in systems intended for surgical implant into the body, or other applications intended to support or sustain life, or for any other application in which the failure of the SCILLC product could create a situation where personal injury or death may occur. Should Buyer purchase or use SCILLC products for any such unintended or unauthorized application, Buyer shall indemnify and hold SCILLC and its officers, employees, subsidiaries, affiliates, and distributors harmless against all claims, costs, damages, and expenses, and reasonable attorney fees arising out of, directly or indirectly, any claim of personal injury or death associated with such unintended or unauthorized use, even if such claim alleges that SCILLC was negligent regarding the design or manufacture of the part. SCILLC is an Equal Opportunity/Affirmative Action Employer.

PUBLICATION ORDERING INFORMATION

NORTH AMERICA Literature Fulfillment:

Literature Distribution Center for ON Semiconductor
P.O. Box 5163, Denver, Colorado 80217 USA
Phone: 303-675-2175 or 800-344-3860 Toll Free USA/Canada
Fax: 303-675-2176 or 800-344-3867 Toll Free USA/Canada
Email: ONlit@hibbertco.com
Fax Response Line: 303-675-2167 or 800-344-3810 Toll Free USA/Canada

N. American Technical Support: 800-282-9855 Toll Free USA/Canada

EUROPE: LDC for ON Semiconductor – European Support

German Phone: (+1) 303-308-7140 (Mon-Fri 2:30pm to 7:00pm CET)
Email: ONlit-german@hibbertco.com
French Phone: (+1) 303-308-7141 (Mon-Fri 2:00pm to 7:00pm CET)
Email: ONlit-french@hibbertco.com
English Phone: (+1) 303-308-7142 (Mon-Fri 12:00pm to 5:00pm GMT)
Email: ONlit@hibbertco.com

EUROPEAN TOLL-FREE ACCESS*: 00-800-4422-3781

*Available from Germany, France, Italy, England, Ireland

CENTRAL/SOUTH AMERICA:

Spanish Phone: 303-308-7143 (Mon-Fri 8:00am to 5:00pm MST)
Email: ONlit-spanish@hibbertco.com

ASIA/PACIFIC: LDC for ON Semiconductor – Asia Support

Phone: 303-675-2121 (Tue-Fri 9:00am to 1:00pm, Hong Kong Time)
Toll Free from Hong Kong & Singapore:
001-800-4422-3781
Email: ONlit-asia@hibbertco.com

JAPAN: ON Semiconductor, Japan Customer Focus Center
4-32-1 Nishi-Gotanda, Shinagawa-ku, Tokyo, Japan 141-0031
Phone: 81-3-5740-2745
Email: r14525@onsemi.com

ON Semiconductor Website: <http://onsemi.com>

For additional information, please contact your local Sales Representative.