



Chipsmall Limited consists of a professional team with an average of over 10 year of expertise in the distribution of electronic components. Based in Hongkong, we have already established firm and mutual-benefit business relationships with customers from,Europe,America and south Asia,supplying obsolete and hard-to-find components to meet their specific needs.

With the principle of "Quality Parts,Customers Priority,Honest Operation,and Considerate Service",our business mainly focus on the distribution of electronic components. Line cards we deal with include Microchip,ALPS,ROHM,Xilinx,Pulse,ON,Everlight and Freescale. Main products comprise IC,Modules,Potentiometer,IC Socket,Relay,Connector.Our parts cover such applications as commercial,industrial, and automotives areas.

We are looking forward to setting up business relationship with you and hope to provide you with the best service and solution. Let us make a better world for our industry!



## Contact us

Tel: +86-755-8981 8866 Fax: +86-755-8427 6832

Email & Skype: info@chipsmall.com Web: www.chipsmall.com

Address: A1208, Overseas Decoration Building, #122 Zhenhua RD., Futian, Shenzhen, China





# Quad high-side switch (quad 15 mOhm)

The 15XS3400 is one in a family of devices designed for low-voltage automotive lighting applications. Its four low  $R_{DS(on)}$  MOSFETs (quad 15 mOhm) can control four separate 55 W/28 W bulbs, and/or Xenon modules, and/or LEDs.

Programming, control and diagnostics are accomplished using a 16-bit SPI interface. Its output with selectable slew rate improves electromagnetic compatibility (EMC) behavior. Additionally, each output has its own parallel input or SPI control for pulse-width modulation (PWM) control. The 15XS3400 allows the user to program via the SPI the fault current trip levels and duration of acceptable lamp inrush. The device has Fail-safe mode to provide functionality of the outputs in case of MCU damage.

**15XS3400**

**HIGH-SIDE SWITCH**

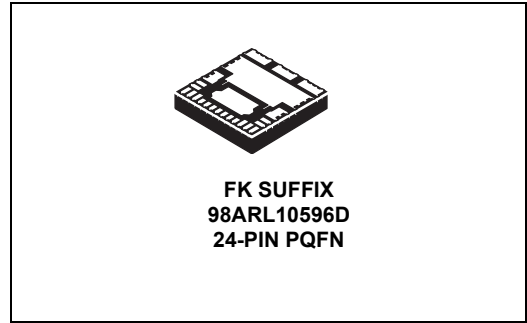

**Features**

- Four protected 15 mΩ high-side switches (at 25 °C)
- Operating voltage range of 6.0 V to 20 V with standby current < 5.0 μA, extended mode from 4.0 V to 28 V
- 8.0 MHz 16-bit 3.3 V and 5.0 V SPI control and status reporting with daisy chain capability
- PWM module using external clock or calibratable internal oscillator with programmable outputs delay management
- Smart overcurrent shutdown, severe short-circuit, overtemperature protection with time limited autoretry, and Fail-safe mode in case of MCU damage
- Output OFF or ON openload detection compliant to bulbs or LEDs and short to battery detection
- Analog current feedback with selectable ratio and board temperature feedback

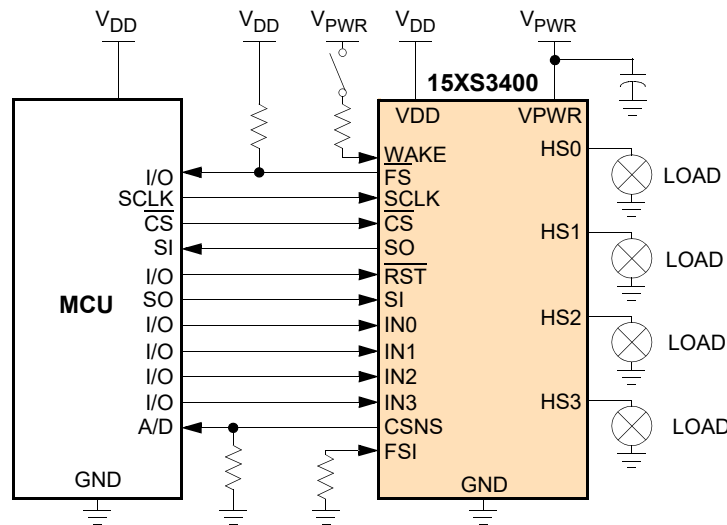

Figure 1. 15XS3400 simplified application diagram



# Table of Contents

1	Orderable parts	3
2	Device variations	3
3	Internal block diagram	4
4	Pin connections	5
5	Electrical characteristics	7
5.1	Maximum ratings	7
5.2	Static electrical characteristics	9
5.3	Dynamic electrical characteristics	14
5.4	Timing diagrams	21
6	Functional description	24
6.1	Introduction	24
6.2	Functional pin description	24
6.3	Functional internal block description	26
7	Functional device operation	27
7.1	SPI protocol description	27
7.2	Operational modes	27
7.3	Protection and diagnostic features	32
7.4	Logic commands and registers	37
8	Typical applications	45
9	Packaging	46
9.1	Soldering information	46
9.2	Package dimensions	47
10	Additional documentation	51
10.1	Thermal addendum (Rev 2.0)	51
11	Revision history	56

# 1 Orderable parts

This section describes the part numbers available to be purchased along with their differences. Valid orderable part numbers are provided on the web. To determine the orderable part numbers for this device, go to <http://www.nxp.com> and perform a part number search for the following device numbers.

**Table 1. Orderable part variations**

Part number <sup>(1)</sup>	Temperature (T <sub>A</sub> )	Package
MC15XS3400CHFK	-40 °C to 125 °C	24-pin PQFN
MC15XS3400DHFk		

Notes

1. To order parts in tape and reel, add the R2 suffix to the part number.

# 2 Device variations

**Table 2. Device variations**

Characteristic	Symbol	Min	Typ	Max	Unit
Wake input clamp voltage, I <sub>CL(WAKE)</sub> < 2.5 mA • 15XS3400C • 15XS3400D	V <sub>CL(WAKE)</sub>	18 20	25 27	32 35	V
Fault detection blanking time • 15XS3400C • 15XS3400D	t <sub>FAULT</sub>	- -	5.0 5.0	20 10	μs
Output shutdown delay time • 15XS3400C • 15XS3400D	t <sub>DETECT</sub>	- -	7.0 7.0	30 20	μs
Peak Package Reflow Temperature During Reflow <sup>(2), (3)</sup>	T <sub>PPRT</sub>	Note 3			°C

Notes

2. Pin soldering temperature limit is for 40 seconds maximum duration. Not designed for immersion soldering. Exceeding these limits may cause malfunction or permanent damage to the device.
3. NXP's Package Reflow capability meets Pb-free requirements for JEDEC standard J-STD-020C. For Peak Package Reflow Temperature and Moisture Sensitivity Levels (MSL), go to [www.nxp.com](http://www.nxp.com), search by part number (remove prefixes/suffixes) and enter the core ID to view all orderable parts, and review parametrics.

### 3 Internal block diagram

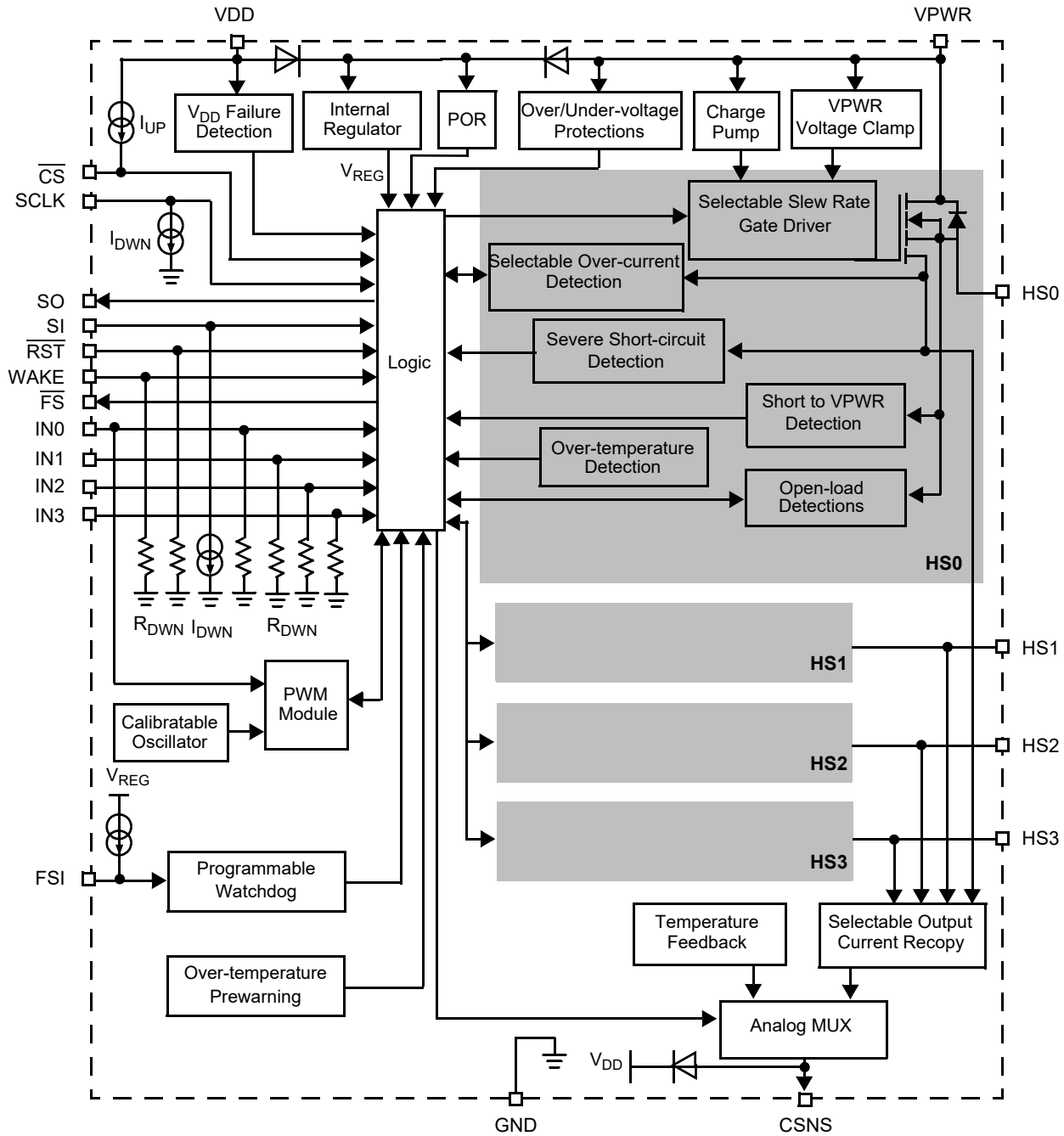

Figure 2. 15XS3400 simplified internal block diagram



## 4 Pin connections

Transparent Top View of Package

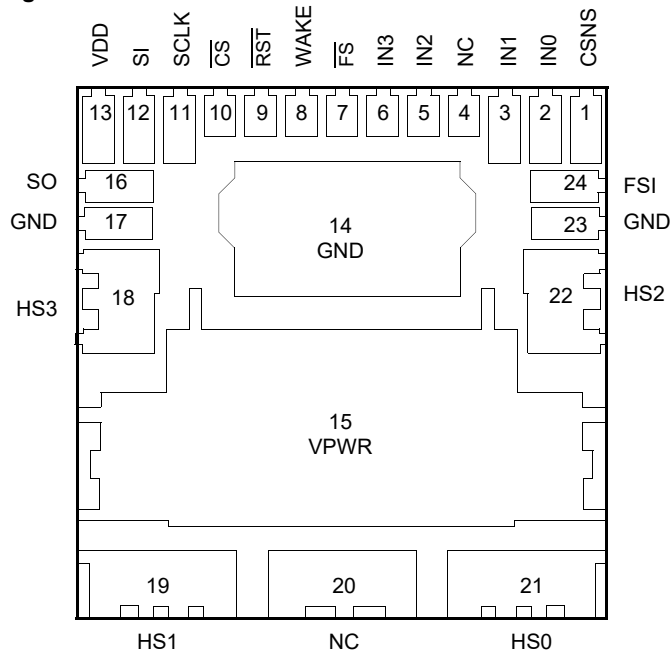

Figure 3. 15XS3400 pin connections

Table 3. 15XS3400 pin definitions

A functional description of each pin can be found in the Functional Pin Description section beginning on page [24](#).

Pin number	Pin name	Pin function	Formal name	Definition
1	CSNS	Output	Output current monitoring	This pin reports an analog value proportional to the designated HS[0:3] output current or the temperature of the GND flag (pin 14). It is used externally to generate a ground-referenced voltage for the microcontroller (MCU). Current recopy and temperature feedback is SPI programmable.
2 3 5 6	IN0 IN1 IN2 IN3	Input	Direct inputs	Each direct input controls the device mode. The IN[0:3] high-side input pins are used to directly control HS0:HS3 high-side output pins. The PWM frequency can be generated from IN0 pin to PWM module in case the external clock is set.
7	FS	Output	Fault status (active low)	This pin is an open drain configured output requiring an external pull-up resistor to V <sub>DD</sub> for fault reporting.
8	WAKE	Input	Wake	This input pin controls the device mode.
9	RST	Input	Reset	This input pin is used to initialize the device configuration and fault registers, as well as place the device in a low-current Sleep mode.
10	CS	Input	Chip select (active low)	This input pin is connected to a chip select output of a master microcontroller (MCU).
11	SCLK	Input	Serial clock	This input pin is connected to the MCU providing the required bit shift clock for SPI communication.
12	SI	Input	Serial input	This pin is a command data input pin connected to the SPI serial data output of the MCU or to the SO pin of the previous device of a daisy-chain of devices.
13	VDD	Power	Digital drain voltage	This pin is an external voltage input pin used to supply power interfaces to the SPI bus.
14, 17, 23	GND	Ground	Ground	These pins, internally shorted, are the ground for the logic and analog circuitry of the device. These ground pins must be also shorted in the board.

**Table 3. 15XS3400 pin definitions (continued)**

A functional description of each pin can be found in the Functional Pin Description section beginning on page [24](#).

Pin number	Pin name	Pin function	Formal name	Definition
15	VPWR	Power	Positive power supply	This pin connects to the positive power supply and is the source of operational power for the device.
16	SO	Output	Serial output	This output pin is connected to the SPI serial data input pin of the MCU or to the SI pin of the next device of a daisy-chain of devices.
18 19 21 22	HS3 HS1 HS0 HS2	Output	High-side outputs	Protected 15 mΩ high-side power output pins to the load.
4, 20	NC	N/A	No connect	These pins may not be connected.
24	FSI	Input	Fail-safe input	This input enables the watchdog timeout feature.

# 5 Electrical characteristics

## 5.1 Maximum ratings

**Table 4. Maximum ratings**

All voltages are with respect to ground unless otherwise noted. Exceeding these ratings may cause a malfunction or permanent damage to the device.

Ratings	Symbol	Value	Unit
<b>ELECTRICAL RATINGS</b>			
V <sub>PWR</sub> supply voltage range <ul style="list-style-type: none"> <li>Load dump at 25 °C (400 ms)</li> <li>Maximum operating voltage</li> <li>Reverse battery at 25 °C (2.0 min)</li> </ul>	V <sub>PWR(SS)</sub>	41 28 -18	V
V <sub>DD</sub> supply voltage range	V <sub>DD</sub>	-0.3 to 5.5	V
Input/output voltage	(7)	-0.3 to V <sub>DD</sub> +0.3	V
WAKE input clamp current	I <sub>CL(WAKE)</sub>	2.5	mA
CSNS input clamp current	I <sub>CL(CSNS)</sub>	2.5	mA
HS [0:3] voltage <ul style="list-style-type: none"> <li>Positive</li> <li>Negative</li> </ul>	V <sub>HS[0:3]</sub>	41 -16	V
Output current <sup>(4)</sup>	I <sub>HS[0:3]</sub>	6	A
Output clamp energy using single-pulse method <sup>(5)</sup>	E <sub>CL[0:3]</sub>	100	mJ
ESD voltage <sup>(6)</sup> <ul style="list-style-type: none"> <li>Human Body Model (HBM) for HS[0:3], V<sub>PWR</sub> and GND</li> <li>Human Body Model (HBM) for other pins</li> <li>Charge Device Model (CDM)               <ul style="list-style-type: none"> <li>Corner pins (1, 13, 19, 21)</li> <li>All other pins (2-12, 14-18, 20, 22-24)</li> </ul> </li> </ul>	V <sub>ESD1</sub> V <sub>ESD2</sub>  V <sub>ESD3</sub> V <sub>ESD4</sub>	±8000 ±2000  ±750 ±500	V
<b>THERMAL RATINGS</b>			
Operating temperature <ul style="list-style-type: none"> <li>Ambient</li> <li>Junction</li> </ul>	T <sub>A</sub> T <sub>J</sub>	-40 to 125 -40 to 150	°C
Storage temperature	T <sub>STG</sub>	-55 to 150	°C

**Notes**

- Continuous high-side output current rating so long as maximum junction temperature is not exceeded. Calculation of maximum output current using package thermal resistance is required.
- Active clamp energy using single-pulse method (L = 2.0 mH, R<sub>L</sub> = 0 Ω, V<sub>PWR</sub> = 14 V, T<sub>J</sub> = 150°C initial).
- ESD testing is performed in accordance with the Human Body Model (HBM) (C<sub>ZAP</sub> = 100 pF, R<sub>ZAP</sub> = 1500 Ω), the Machine Model (MM) (C<sub>ZAP</sub> = 200 pF, R<sub>ZAP</sub> = 0 Ω), and the Charge Device Model (CDM), Robotic (C<sub>ZAP</sub> = 4.0 pF).
- Input / Output pins are: IN[0:3],  $\overline{RST}$ , FSI, CSNS, SI, SCLK,  $\overline{CS}$ , SO,  $\overline{FS}$



**Table 4. Maximum ratings (continued)**

All voltages are with respect to ground unless otherwise noted. Exceeding these ratings may cause a malfunction or permanent damage to the device.

Ratings	Symbol	Value	Unit
<b>THERMAL RESISTANCE</b>			
Thermal resistance <sup>(8)</sup> <ul style="list-style-type: none"> <li>• Junction to Case</li> <li>• Junction to Ambient</li> </ul>	$R_{\theta JC}$ $R_{\theta JA}$	<1.0 30	°C/W
Peak Package Reflow Temperature During Reflow <sup>(9), (10)</sup>	$T_{PPRT}$	Note 10	°C

**Notes**

8. Device mounted on a 2s2p test board per JEDEC JESD51-2. 15 °C/W of  $R_{\theta JA}$  can be reached in a real application case (4 layers board).
9. Pin soldering temperature limit is for 40 seconds maximum duration. Not designed for immersion soldering. Exceeding these limits may cause malfunction or permanent damage to the device.
10. NXP's Package Reflow capability meets Pb-free requirements for JEDEC standard J-STD-020C. For Peak Package Reflow Temperature and Moisture Sensitivity Levels (MSL), go to [www.nxp.com](http://www.nxp.com), search by part number (remove prefixes/suffixes) and enter the core ID to view all orderable parts, and review parametrics.

## 5.2 Static electrical characteristics

**Table 5. Static electrical characteristics**

Characteristics noted under conditions  $6.0\text{ V} \leq V_{PWR} \leq 20\text{ V}$ ,  $3.0\text{ V} \leq V_{DD} \leq 5.5\text{ V}$ ,  $-40\text{ }^\circ\text{C} \leq T_A \leq 125\text{ }^\circ\text{C}$ ,  $\text{GND} = 0\text{ V}$ , unless otherwise noted. Typical values noted reflect the approximate parameter means at  $T_A = 25\text{ }^\circ\text{C}$  under nominal conditions, unless otherwise noted.

Characteristic	Symbol	Min	Typ	Max	Unit
<b>POWER INPUTS</b>					
Battery supply voltage range <ul style="list-style-type: none"> <li>Fully operational</li> <li>Extended mode<sup>(11)</sup></li> </ul>	$V_{PWR}$	6.0 4.0	– –	20 28	V
Battery clamp voltage <sup>(12)</sup>	$V_{PWR(\text{CLAMP})}$	41	47	53	V
$V_{PWR}$ operating supply current <ul style="list-style-type: none"> <li>Outputs commanded ON, HS[0:3] open, IN[0:3] &gt; <math>V_{IH}</math></li> </ul>	$I_{PWR(\text{ON})}$	–	6.5	20	mA
$V_{PWR}$ supply current <ul style="list-style-type: none"> <li>Outputs commanded OFF, OFF Open-load Detection Disabled, HS[0:3] shorted to the ground with <math>V_{DD} = 5.5\text{ V}</math></li> <li>WAKE &gt; <math>V_{IH}</math> or <math>\overline{\text{RST}} &gt; V_{IH}</math> and IN[0:3] &lt; <math>V_{IL}</math></li> </ul>	$I_{PWR(\text{SBY})}$	–	6.0	8.0	mA
Sleep state supply current <ul style="list-style-type: none"> <li><math>V_{PWR} = 12\text{ V}</math>, <math>\overline{\text{RST}} = \text{WAKE} = \text{IN}[0:3] &lt; V_{IL}</math>, HS[0:3] shorted to the ground</li> <li><math>T_A = 25\text{ }^\circ\text{C}</math></li> <li><math>T_A = 85\text{ }^\circ\text{C}</math></li> </ul>	$I_{PWR(\text{SLEEP})}$	– –	1.0 –	5.0 30	$\mu\text{A}$
$V_{DD}$ supply voltage	$V_{DD(\text{ON})}$	3.0	–	5.5	V
$V_{DD}$ supply current at $V_{DD} = 5.5\text{ V}$ <ul style="list-style-type: none"> <li>No SPI communication</li> <li>8.0 MHz SPI communication<sup>(13)</sup></li> </ul>	$I_{DD(\text{ON})}$	– –	1.6 5.0	2.2 –	mA
$V_{DD}$ sleep state current at $V_{DD} = 5.5\text{ V}$	$I_{DD(\text{SLEEP})}$	–	–	5.0	$\mu\text{A}$
Overvoltage shutdown threshold	$V_{PWR(\text{OV})}$	28	32	36	V
Overvoltage shutdown hysteresis	$V_{PWR(\text{OVHYS})}$	0.2	0.8	1.5	V
Undervoltage shutdown threshold <sup>(14)</sup>	$V_{PWR(\text{UV})}$	3.3	3.9	4.3	V
Recovery undervoltage shutdown threshold	$V_{PWR(\text{UV})\_UP}$	3.4	4.1	4.5	V
$V_{PWR}$ and $V_{DD}$ power-on reset threshold	$V_{\text{SUPPLY}(\text{POR})}$	0.5	–	0.9	$V_{PWR}$ (UV)
$V_{DD}$ supply failure threshold (for $V_{PWR} > V_{PWR(\text{UV})}$ )	$V_{DD(\text{FAIL})}$	2.2	2.5	2.8	

**Notes**

- In Extended mode, the functionality is guaranteed but not the electrical parameters. From 4.0 V to 6.0 V voltage range, the device is only protected with the thermal shutdown detection.
- Measured with the outputs open.
- Typical value guaranteed per design.
- Output will automatically recover with time limited autoretry to instructed state when  $V_{PWR}$  voltage is restored to normal as long as the  $V_{PWR}$  degradation level did not go below the undervoltage power-on reset threshold. This applies to all internal device logic that is supplied by  $V_{PWR}$  and assumes that the external  $V_{DD}$  supply is within specification.



**Table 5. Static electrical characteristics (continued)**

Characteristics noted under conditions  $6.0\text{ V} \leq V_{\text{PWR}} \leq 20\text{ V}$ ,  $3.0\text{ V} \leq V_{\text{DD}} \leq 5.5\text{ V}$ ,  $-40\text{ }^\circ\text{C} \leq T_{\text{A}} \leq 125\text{ }^\circ\text{C}$ ,  $\text{GND} = 0\text{ V}$ , unless otherwise noted. Typical values noted reflect the approximate parameter means at  $T_{\text{A}} = 25\text{ }^\circ\text{C}$  under nominal conditions, unless otherwise noted.

Characteristic	Symbol	Min	Typ	Max	Unit
Current sense ratio ( $6.0\text{ V} \leq V_{\text{HS}[0:3]} \leq 20\text{ V}$ , $\text{CSNS} \leq 5.0\text{ V}$ ) <sup>(17)</sup> <ul style="list-style-type: none"> <li>• 28 W bit = 0           <ul style="list-style-type: none"> <li>CSNS_ratio bit = 0</li> <li>CSNS_ratio bit = 1</li> </ul> </li> <li>• 28 W bit = 1           <ul style="list-style-type: none"> <li>CSNS_ratio bit = 0</li> <li>CSNS_ratio bit = 1</li> </ul> </li> </ul>	 CSR0_0 CSR1_0  CSR0_1 CSR1_1	 – –  – –	 1/8700 1/49000  1/4350 1/26500	 – –  – –	 –    –
Current sense ratio (CSR0) accuracy ( $6.0\text{ V} \leq V_{\text{HS}[0:3]} \leq 20\text{ V}$ ) with 28 W bit=0 <ul style="list-style-type: none"> <li>• Output current               <ul style="list-style-type: none"> <li>12.5 A</li> <li>5.0 A</li> <li>3.0 A</li> <li>1.5 A</li> </ul> </li> </ul>	CSR0_0_ACC	-12 -13 -16 -20	– – – –	12 13 16 20	%
Current sense ratio (CSR0) accuracy ( $6.0\text{ V} \leq V_{\text{HS}} \leq 20\text{ V}$ ) with 28 W bit=1 <ul style="list-style-type: none"> <li>• Output current               <ul style="list-style-type: none"> <li>3.0 A</li> <li>1.5 A</li> </ul> </li> </ul>	CSR0_1_ACC	-16 -20	– –	16 20	%
CSR0 current recopy accuracy with one calibration point ( $6.0\text{ V} \leq V_{\text{HS}[0:3]} \leq 20\text{ V}$ ) <sup>(18)</sup> <ul style="list-style-type: none"> <li>• Output current               <ul style="list-style-type: none"> <li>5.0 A</li> </ul> </li> </ul>	CSR0_0_ACC(CAL)	-5.0	–	5.0	%

**Notes**

17. Current sense ratio =  $I_{\text{CSNS}} / I_{\text{HS}[0:3]}$ .
18. Based on statistical analysis, it is not production tested.

**Table 5. Static electrical characteristics (continued)**

Characteristics noted under conditions  $6.0\text{ V} \leq V_{PWR} \leq 20\text{ V}$ ,  $3.0\text{ V} \leq V_{DD} \leq 5.5\text{ V}$ ,  $-40\text{ }^\circ\text{C} \leq T_A \leq 125\text{ }^\circ\text{C}$ ,  $\text{GND} = 0\text{ V}$ , unless otherwise noted. Typical values noted reflect the approximate parameter means at  $T_A = 25\text{ }^\circ\text{C}$  under nominal conditions, unless otherwise noted.

Characteristic	Symbol	Min	Typ	Max	Unit
<b>OUTPUTS HS0 TO HS3 (continued)</b>					
$C_{SR0}$ current recopy temperature drift ( $6.0\text{ V} \leq V_{HS[0:3]} \leq 20\text{ V}$ ) with 28 W bit=0 <sup>(19)</sup> <ul style="list-style-type: none"> <li>Output current</li> <li>5.0 A</li> </ul>	$\Delta(C_{SR0\_0})/\Delta(T)$			0.04	%/ $^\circ\text{C}$
Current sense ratio ( $C_{SR1}$ ) accuracy ( $6.0\text{ V} \leq V_{HS[0:3]} \leq 20\text{ V}$ ) with 28 W bit=0 <ul style="list-style-type: none"> <li>Output current</li> <li>12.5 A</li> <li>75 A</li> </ul>	$C_{SR1\_0\_ACC}$	-17 -12	- -	+17 +12	%
Current sense clamp voltage <ul style="list-style-type: none"> <li>CSNS open; <math>I_{HS[0:3]} = 5.0\text{ A}</math> with <math>C_{SR0}</math> ratio</li> </ul>	$V_{CL}(CSNS)$	$V_{DD}+0.25$	-	$V_{DD}+1.0$	V
OFF openload detection source current <sup>(20)</sup>	$I_{OLD}(OFF)$	30	-	100	$\mu\text{A}$
OFF openload fault detection voltage threshold	$V_{OLD}(THRES)$	2.0	3.0	4.0	V
ON openload fault detection current threshold	$I_{OLD}(ON)$	100	300	600	mA
ON openload fault detection current threshold with LED $V_{HS[0:3]} = V_{PWR} - 0.75\text{ V}$	$I_{OLD}(ON\_LED)$	2.5	5.0	10	mA
Output short to $V_{PWR}$ detection voltage threshold Output programmed OFF	$V_{OSD}(THRES)$	$V_{PWR}-1.2$	$V_{PWR}-0.8$	$V_{PWR}-0.4$	V
Output negative clamp voltage <ul style="list-style-type: none"> <li><math>0.5\text{ A} \leq I_{HS[0:3]} \leq 5.0\text{ A}</math>, output programmed OFF</li> </ul>	$V_{CL}$	-22	-	-16	V
Output overtemperature shutdown (for $4.5\text{ V} < V_{PWR} < 28\text{ V}$ )	$T_{SD}$	155	175	195	$^\circ\text{C}$

**Notes**

- Based on statistical data:  $\Delta(C_{SR0})/\Delta(T) = \{(\text{measured } I_{CSNS} \text{ at } T_1 - \text{measured } I_{CSNS} \text{ at } T_2) / \text{measured } I_{CSNS} \text{ at room}\} / \{T_1 - T_2\}$ . No production tested.
- Output OFF openload detection current is the current required to flow through the load for the purpose of detecting the existence of an openload condition when the specific output is commanded OFF. Pull-up current is measured for  $V_{HS} = V_{OLD}(THRES)$

**Table 5. Static electrical characteristics (continued)**

Characteristics noted under conditions  $6.0\text{ V} \leq V_{PWR} \leq 20\text{ V}$ ,  $3.0\text{ V} \leq V_{DD} \leq 5.5\text{ V}$ ,  $-40\text{ }^\circ\text{C} \leq T_A \leq 125\text{ }^\circ\text{C}$ ,  $\text{GND} = 0\text{ V}$ , unless otherwise noted. Typical values noted reflect the approximate parameter means at  $T_A = 25\text{ }^\circ\text{C}$  under nominal conditions, unless otherwise noted.

Characteristic	Symbol	Min	Typ	Max	Unit
<b>CONTROL INTERFACE</b>					
Input logic high voltage <sup>(21)</sup>	$V_{IH}$	2.0	–	$V_{DD}+0.3$	V
Input logic low voltage <sup>(21)</sup>	$V_{IL}$	-0.3	–	0.8	V
Input logic pull-down current (SCLK, SI) <sup>(24)</sup>	$I_{DWN}$	5.0	–	20	$\mu\text{A}$
Input logic pull-up current ( $\overline{\text{CS}}$ ) <sup>(25)</sup>	$I_{UP}$	5.0	–	20	$\mu\text{A}$
SO, $\overline{\text{FS}}$ tri-state capacitance <sup>(22)</sup>	$C_{SO}$	–	–	20	pF
Input logic pull-down resistor ( $\overline{\text{RST}}$ , WAKE and IN[0:3])	$R_{DWN}$	125	250	500	k $\Omega$
Input capacitance <sup>(22)</sup>	$C_{IN}$	–	4.0	12	pF
Wake input clamp voltage <sup>(23)</sup> , $I_{CL(\text{WAKE})} < 2.5\text{ mA}$ • 15XS3400C • 15XS3400D	$V_{CL(\text{WAKE})}$	18 20	25 27	32 35	V
Wake input forward voltage • $I_{CL(\text{WAKE})} = -2.5\text{ mA}$	$V_{F(\text{WAKE})}$	-2.0	–	-0.3	V
SO high state output voltage • $I_{OH} = 1.0\text{ mA}$	$V_{SOH}$	$V_{DD}-0.4$	–	–	V
SO and $\overline{\text{FS}}$ low-state output voltage • $I_{OL} = -1.0\text{ mA}$	$V_{SOL}$	–	–	0.4	V
SO, CSNS and $\overline{\text{FS}}$ tri-state leakage current • $\overline{\text{CS}} = V_{IH}$ and $0\text{ V} \leq V_{SO} \leq V_{DD}$ , or $\overline{\text{FS}} = 5.5\text{ V}$ , or CSNS=0.0 V	$I_{SO(\text{LEAK})}$	-2.0	0	2.0	$\mu\text{A}$
FSI external pull-down resistance <sup>(26)</sup> • Watchdog disabled • Watchdog enabled	RFS	– 10	0 Infinite	1.0 –	k $\Omega$

**Notes**

- Upper and lower logic threshold voltage range applies to SI,  $\overline{\text{CS}}$ , SCLK,  $\overline{\text{RST}}$ , IN[0:3] and WAKE input signals. The WAKE and  $\overline{\text{RST}}$  signals may be supplied by a derived voltage referenced to  $V_{PWR}$ .
- Input capacitance of SI,  $\overline{\text{CS}}$ , SCLK,  $\overline{\text{RST}}$ , IN[0:3] and WAKE. This parameter is guaranteed by process monitoring but is not production tested.
- The current must be limited by a series resistance when using voltages  $> 7.0\text{ V}$ .
- Pull-down current is with  $V_{SI} \geq 1.0\text{ V}$  and  $V_{SCLK} \geq 1.0\text{ V}$ .
- Pull-up current is with  $V_{\overline{\text{CS}}} \leq 2.0\text{ V}$ .  $\overline{\text{CS}}$  has an active internal pull-up to  $V_{DD}$ .
- In Fail-safe HS[0:3] depends respectively on ON[0:3]. FSI has an active internal pull-up to  $V_{REG} \sim 3.0\text{ V}$ .



## 5.3 Dynamic electrical characteristics

**Table 6. Dynamic electrical characteristics**

Characteristics noted under conditions  $6.0\text{ V} \leq V_{PWR} \leq 20\text{ V}$ ,  $3.0\text{ V} \leq V_{DD} \leq 5.5\text{ V}$ ,  $-40\text{ }^\circ\text{C} \leq T_A \leq 125\text{ }^\circ\text{C}$ ,  $\text{GND} = 0\text{ V}$ , unless otherwise noted. Typical values noted reflect the approximate parameter means at  $T_A = 25\text{ }^\circ\text{C}$  under nominal conditions, unless otherwise noted.

Characteristic	Symbol	Min	Typ	Max	Unit
<b>POWER OUTPUT TIMING HS0 TO HS3</b>					
Output rising medium slew rate (medium speed slew rate / SR[1:0]=00) <sup>(27)</sup> • $V_{PWR} = 14\text{ V}$	SR <sub>R_00</sub>	0.15	0.3	0.6	V/ $\mu\text{s}$
Output rising slow slew rate (low speed slew rate / SR[1:0]=01) <sup>(27)</sup> • $V_{PWR} = 14\text{ V}$	SR <sub>R_01</sub>	0.07	0.15	0.3	V/ $\mu\text{s}$
Output falling fast slew rate (high speed slew rate / SR[1:0]=10) <sup>(27)</sup> • $V_{PWR} = 14\text{ V}$	SR <sub>R_10</sub>	0.3	0.6	1.2	V/ $\mu\text{s}$
Output falling medium slew rate (medium speed slew rate / SR[1:0]=00) <sup>(27)</sup> • $V_{PWR} = 14\text{ V}$	SR <sub>F_00</sub>	0.15	0.3	0.6	V/ $\mu\text{s}$
Output falling slow slew rate (low speed slew rate / SR[1:0]=01) <sup>(27)</sup> • $V_{PWR} = 14\text{ V}$	SR <sub>F_01</sub>	0.07	0.15	0.3	V/ $\mu\text{s}$
Output rising fast slew rate (high speed slew rate / SR[1:0]=10) <sup>(27)</sup> • $V_{PWR} = 14\text{ V}$	SR <sub>F_10</sub>	0.3	0.6	1.2	V/ $\mu\text{s}$
Output turn-on delay time <sup>(28)</sup> • $V_{PWR} = 14\text{ V}$ for medium speed slew rate (SR[1:0]=00)	t <sub>DLY(ON)</sub>	40	60	90	$\mu\text{s}$
Output turn-off delay time <sup>(29)</sup> • $V_{PWR} = 14\text{ V}$ for medium speed slew rate (SR[1:0]=00)	t <sub>DLY(OFF)</sub>	40	60	90	$\mu\text{s}$
Driver output matching slew rate (SR <sub>R</sub> / SR <sub>F</sub> ) $V_{PWR} = 14\text{ V}$ @ $25\text{ }^\circ\text{C}$ and for medium speed slew rate (SR[1:0]=00)	$\Delta\text{SR}$	0.8	1.0	1.2	
Driver output matching time (t <sub>DLY(ON)</sub> - t <sub>DLY(OFF)</sub> ) $V_{PWR} = 14\text{ V}$ , $f_{\text{PWM}} = 240\text{ Hz}$ , PWM duty cycle = 50%, @ $25\text{ }^\circ\text{C}$ for medium speed slew rate (SR[1:0]=00)	$\Delta t_{\text{RF}}$	-25	0	25	$\mu\text{s}$

### Notes

27. Rise and fall slew rates measured across a  $5.0\ \Omega$  resistive load at high-side output = 30% to 70% (see [Figure 4](#), page 21).
28. Turn-on delay time measured from rising edge of any signal (IN[0:3] and  $\overline{\text{CS}}$ ) that would turn the output ON to  $V_{\text{HS}[0:3]} = V_{\text{PWR}} / 2$  with  $R_L = 5.0\ \Omega$  resistive load.
29. Turn-off delay time measured from falling edge of any signal (IN[0:3] and  $\overline{\text{CS}}$ ) that would turn the output OFF to  $V_{\text{HS}[0:3]} = V_{\text{PWR}} / 2$  with  $R_L = 5.0\ \Omega$  resistive load.

**Table 6. Dynamic electrical characteristics (continued)**

Characteristics noted under conditions  $6.0\text{ V} \leq V_{PWR} \leq 20\text{ V}$ ,  $3.0\text{ V} \leq V_{DD} \leq 5.5\text{ V}$ ,  $-40\text{ }^\circ\text{C} \leq T_A \leq 125\text{ }^\circ\text{C}$ ,  $\text{GND} = 0\text{ V}$ , unless otherwise noted. Typical values noted reflect the approximate parameter means at  $T_A = 25\text{ }^\circ\text{C}$  under nominal conditions, unless otherwise noted.

Characteristic	Symbol	Min	Typ	Max	Unit
<b>POWER OUTPUT TIMING HS0 TO HS3 (continued)</b>					
Fault detection blanking time <sup>(30)</sup> • 15XS3400C • 15XS3400D	$t_{\text{FAULT}}$	- -	5.0 5.0	20 10	$\mu\text{s}$
Output shutdown delay time <sup>(31)</sup> • 15XS3400C • 15XS3400D	$t_{\text{DETECT}}$	- -	7.0 7.0	30 20	$\mu\text{s}$
$\overline{\text{CS}}$ to CSNS valid time <sup>(32)</sup>	$t_{\text{CNSVAL}}$	-	70	100	$\mu\text{s}$
Watchdog timeout <sup>(33)</sup>	$t_{\text{WDTO}}$	217	310	400	ms
ON openload fault cyclic detection period with LED • Internal clock (PWM_en bit = 1 & CLOCK_Set = 1) • External clock (PWM_en bit = 1 & CLOCK_Set = 0)	$T_{\text{OLLED}}$	6.4 -	8.3 PWM period	12 -	ms

**Notes**

30. Time necessary to report the fault to  $\overline{\text{FS}}$  pin.
31. Time necessary to switch-off the output in case of OT or OC or SC or UV fault detection (from negative edge of  $\overline{\text{FS}}$  pin to HS voltage = 50% of  $V_{PWR}$
32. Time necessary for the CSNS to be with  $\pm 5\%$  of the targeted value (from HS voltage = 50% of  $V_{PWR}$  to  $\pm 5\%$  of the targeted CSNS value).
33. For FSI open, the watchdog timeout delay measured from the rising edge of RST, to HS[0,2] output state depend on the corresponding input command.

**Table 6. Dynamic electrical characteristics (continued)**

Characteristics noted under conditions  $6.0\text{ V} \leq V_{\text{PWR}} \leq 20\text{ V}$ ,  $3.0\text{ V} \leq V_{\text{DD}} \leq 5.5\text{ V}$ ,  $-40\text{ }^\circ\text{C} \leq T_{\text{A}} \leq 125\text{ }^\circ\text{C}$ ,  $\text{GND} = 0\text{ V}$ , unless otherwise noted. Typical values noted reflect the approximate parameter means at  $T_{\text{A}} = 25\text{ }^\circ\text{C}$  under nominal conditions, unless otherwise noted.

Characteristic	Symbol	Min	Typ	Max	Unit
Output overcurrent time step for 28 W bit = 0					ms
OC[1:0]=00 (slow by default)	$t_{\text{OC1\_00}}$	4.40	6.30	8.02	
	$t_{\text{OC2\_00}}$	1.62	2.32	3.00	
	$t_{\text{OC3\_00}}$	2.10	3.00	3.90	
	$t_{\text{OC4\_00}}$	2.88	4.12	5.36	
	$t_{\text{OC5\_00}}$	4.58	6.56	8.54	
	$t_{\text{OC6\_00}}$	10.16	14.52	18.88	
	$t_{\text{OC7\_00}}$	73.2	104.6	134.0	
OC[1:0]=01 (fast)	$t_{\text{OC1\_01}}$	1.10	1.57	2.00	
	$t_{\text{OC2\_01}}$	0.40	0.58	0.75	
	$t_{\text{OC3\_01}}$	0.52	0.75	0.98	
	$t_{\text{OC4\_01}}$	0.72	1.03	1.34	
	$t_{\text{OC5\_01}}$	1.14	1.64	2.13	
	$t_{\text{OC6\_01}}$	2.54	3.63	4.72	
	$t_{\text{OC7\_01}}$	18.2	26.1	34.0	
OC[1:0]=10 (medium)	$t_{\text{OC1\_10}}$	2.20	3.15	4.01	
	$t_{\text{OC2\_10}}$	0.81	1.16	1.50	
	$t_{\text{OC3\_10}}$	1.05	1.50	1.95	
	$t_{\text{OC4\_10}}$	1.44	2.06	2.68	
	$t_{\text{OC5\_10}}$	2.29	3.28	4.27	
	$t_{\text{OC6\_10}}$	5.08	7.26	9.44	
	$t_{\text{OC7\_10}}$	36.6	52.3	68.0	
OC[1:0]=11 (very slow)	$t_{\text{OC1\_11}}$	8.8	12.6	16.4	
	$t_{\text{OC2\_11}}$	3.2	4.6	21.4	
	$t_{\text{OC3\_11}}$	4.2	6.0	7.8	
	$t_{\text{OC4\_11}}$	5.7	8.2	10.7	
	$t_{\text{OC5\_11}}$	9.1	13.1	17.0	
	$t_{\text{OC6\_11}}$	20.3	29.0	37.7	
	$t_{\text{OC7\_11}}$	146.4	209.2	272.0	

**Table 6. Dynamic electrical characteristics (continued)**

Characteristics noted under conditions  $6.0\text{ V} \leq V_{\text{PWR}} \leq 20\text{ V}$ ,  $3.0\text{ V} \leq V_{\text{DD}} \leq 5.5\text{ V}$ ,  $-40\text{ }^\circ\text{C} \leq T_{\text{A}} \leq 125\text{ }^\circ\text{C}$ ,  $\text{GND} = 0\text{ V}$ , unless otherwise noted. Typical values noted reflect the approximate parameter means at  $T_{\text{A}} = 25\text{ }^\circ\text{C}$  under nominal conditions, unless otherwise noted.

Characteristic	Symbol	Min	Typ	Max	Unit
Output overcurrent time step for 28 W bit = 1					ms
OC[1:0]=00 (slow by default)	$t_{\text{OC1\_00}}$	3.4	4.9	6.4	
	$t_{\text{OC2\_00}}$	1.1	1.6	2.1	
	$t_{\text{OC3\_00}}$	1.4	2.1	2.8	
	$t_{\text{OC4\_00}}$	2.0	2.9	3.8	
	$t_{\text{OC5\_00}}$	3.4	4.9	6.4	
	$t_{\text{OC6\_00}}$	8.5	12.2	15.9	
	$t_{\text{OC7\_00}}$	62.4	89.2	116.0	
OC[1:0]=01 (fast)	$t_{\text{OC1\_01}}$	0.86	1.24	1.61	
	$t_{\text{OC2\_01}}$	0.28	0.40	0.52	
	$t_{\text{OC3\_01}}$	0.36	0.52	0.68	
	$t_{\text{OC4\_01}}$	0.51	0.74	0.96	
	$t_{\text{OC5\_01}}$	0.78	1.12	1.46	
	$t_{\text{OC6\_01}}$	2.14	3.06	3.98	
	$t_{\text{OC7\_01}}$	20.2	22.2	28.9	
OC[1:0]=10 (medium)	$t_{\text{OC1\_10}}$	1.7	2.5	3.3	
	$t_{\text{OC2\_10}}$	0.5	0.8	1.0	
	$t_{\text{OC3\_10}}$	0.7	1.0	1.3	
	$t_{\text{OC4\_10}}$	1.0	1.5	2.0	
	$t_{\text{OC5\_10}}$	1.7	2.5	3.3	
	$t_{\text{OC6\_10}}$	4.2	6.1	6.0	
	$t_{\text{OC7\_10}}$	31.2	44.6	58.0	
OC[1:0]=11 (very slow)	$t_{\text{OC1\_11}}$	6.8	9.8	12.8	
	$t_{\text{OC2\_11}}$	2.2	3.2	16.7	
	$t_{\text{OC3\_11}}$	2.9	4.2	5.5	
	$t_{\text{OC4\_11}}$	4.0	5.8	7.6	
	$t_{\text{OC5\_11}}$	6.8	9.8	12.8	
	$t_{\text{OC6\_11}}$	17.0	24.4	31.8	
	$t_{\text{OC7\_11}}$	124.8	178.4	232.0	

**Table 6. Dynamic electrical characteristics (continued)**

Characteristics noted under conditions  $6.0\text{ V} \leq V_{PWR} \leq 20\text{ V}$ ,  $3.0\text{ V} \leq V_{DD} \leq 5.5\text{ V}$ ,  $-40\text{ }^\circ\text{C} \leq T_A \leq 125\text{ }^\circ\text{C}$ ,  $\text{GND} = 0\text{ V}$ , unless otherwise noted. Typical values noted reflect the approximate parameter means at  $T_A = 25\text{ }^\circ\text{C}$  under nominal conditions, unless otherwise noted.

Characteristic	Symbol	Min	Typ	Max	Unit
Bulb cooling time step for 28 W bit = 0					ms
CB[1:0]=00 or 11 (medium)	$t_{BC1\_00}$	242	347	452	
	$t_{BC2\_00}$	126	181	236	
	$t_{BC3\_00}$	140	200	260	
	$t_{BC4\_00}$	158	226	294	
	$t_{BC5\_00}$	181	259	337	
	$t_{BC6\_00}$	211	302	393	
CB[1:0]=01 (fast)	$t_{BC1\_01}$	121	173	226	
	$t_{BC2\_01}$	63	90	118	
	$t_{BC3\_01}$	70	100	130	
	$t_{BC4\_01}$	79	113	147	
	$t_{BC5\_01}$	90	129	169	
	$t_{BC6\_01}$	105	151	197	
CB[1:0]=10 (slow)	$t_{BC1\_10}$	484	694	1904	
	$t_{BC2\_10}$	252	362	472	
	$t_{BC3\_10}$	280	400	520	
	$t_{BC4\_10}$	316	452	588	
	$t_{BC5\_10}$	362	518	674	
	$t_{BC6\_10}$	422	604	786	
for 28 W bit = 1					
CB[1:0]=00 or 11 (medium)	$t_{BC1\_00}$	291	417	542	
	$t_{BC2\_00}$	156	224	292	
	$t_{BC3\_00}$	178	255	332	
	$t_{BC4\_00}$	208	298	388	
	$t_{BC5\_00}$	251	359	467	
	$t_{BC6\_00}$	314	449	584	
CB[1:0]=01 (fast)	$t_{BC1\_01}$	146	209	272	
	$t_{BC2\_01}$	78	112	146	
	$t_{BC3\_01}$	88	127	166	
	$t_{BC4\_01}$	101	145	189	
	$t_{BC5\_01}$	126	180	234	
	$t_{BC6\_01}$	226	324	422	
CB[1:0]=10 (slow)	$t_{BC1\_10}$	583	834	1085	
	$t_{BC2\_10}$	312	448	582	
	$t_{BC3\_10}$	357	510	665	
	$t_{BC4\_10}$	417	596	775	
	$t_{BC5\_10}$	501	717	933	
	$t_{BC6\_10}$	628	898	1170	

**Table 6. Dynamic electrical characteristics (continued)**

Characteristics noted under conditions  $6.0\text{ V} \leq V_{\text{PWR}} \leq 20\text{ V}$ ,  $3.0\text{ V} \leq V_{\text{DD}} \leq 5.5\text{ V}$ ,  $-40\text{ }^\circ\text{C} \leq T_{\text{A}} \leq 125\text{ }^\circ\text{C}$ ,  $\text{GND} = 0\text{ V}$ , unless otherwise noted. Typical values noted reflect the approximate parameter means at  $T_{\text{A}} = 25\text{ }^\circ\text{C}$  under nominal conditions, unless otherwise noted.

Characteristic	Symbol	Min	Typ	Max	Unit
<b>PWM MODULE TIMING</b>					
Input PWM clock range on IN0	$f_{\text{IN0}}$	7.68	–	30.72	kHz
Input PWM clock low frequency detection range on IN0 <sup>(34)</sup>	$f_{\text{IN0(LOW)}}$	1.0	2.0	4.0	kHz
Input PWM clock high frequency detection range on IN0 <sup>(34)</sup>	$f_{\text{IN0(HIGH)}}$	100	200	400	kHz
Output PWM frequency range	$f_{\text{PWM}}$	-	-	1000	Hz
Output PWM frequency accuracy using calibrated oscillator	$A_{\text{FPWM(CAL)}}$	-10	–	+10	%
Default output PWM frequency using internal oscillator	$f_{\text{PWM(0)}}$	84	120	156	Hz
$\overline{\text{CS}}$ calibration low minimum time detection range	$t_{\text{CSB(MIN)}}$	14	20	26	$\mu\text{s}$
$\overline{\text{CS}}$ calibration Low Maximum Time Detection Range	$t_{\text{CSB(MAX)}}$	140	200	260	$\mu\text{s}$
Output PWM duty-cycle range for $f_{\text{PWM}} = 400\text{ Hz}$ <sup>(35)</sup>	$R_{\text{PWM\_400}}$	10		98	%
Output PWM duty-cycle range for $f_{\text{PWM}} = 200\text{ Hz}$ <sup>(35)</sup>	$R_{\text{PWM\_200}}$	5.0		98	%
Output PWM duty-cycle range for $f_{\text{PWM}} = 1.0\text{ kHz}$ <sup>(35)</sup>	$R_{\text{PWM\_1k}}$	6.0	-	94	%
<b>INPUT TIMING</b>					
Direct input toggle timeout	$t_{\text{IN}}$	175	250	325	ms
<b>AUTORETRY TIMING</b>					
Autoretry period	$t_{\text{AUTO}}$	105	150	195	ms
<b>TEMPERATURE ON THE GND FLAG</b>					
Thermal prewarning detection <sup>(36)</sup>	$T_{\text{OTWAR}}$	110	125	140	$^\circ\text{C}$
Analog temperature feedback at $T_{\text{A}} = 25\text{ }^\circ\text{C}$ with $R_{\text{CSNS}}=2.5\text{ k}\Omega$	$T_{\text{FEED}}$	1.15	1.20	1.25	V
Analog temperature feedback derating with $R_{\text{CSNS}}=2.5\text{ k}\Omega$ <sup>(37)</sup>	$\text{DT}_{\text{FEED}}$	-3.5	-3.7	-3.9	$\text{mV}/^\circ\text{C}$

**Notes**

34. Clock fail detector available for PWM\_en bit is set to logic [1] and CLOCK\_sel is set to logic [0].
35. The PWM ratio is measured at  $V_{\text{HS}} = 50\%$  of  $V_{\text{PWR}}$  and for the default SR value. It is possible to put the device fully-on (PWM duty-cycle 100%) and fully-off (duty-cycle 0%). For values outside this range, a calibration is needed between the PWM duty-cycle programming and the PWM on the output with  $R_{\text{L}} = 5.0\ \Omega$  resistive load.
36. Typical value guaranteed per design.
37. Value guaranteed per statistical analysis.



**Table 6. Dynamic electrical characteristics (continued)**

Characteristics noted under conditions  $6.0\text{ V} \leq V_{\text{PWR}} \leq 20\text{ V}$ ,  $3.0\text{ V} \leq V_{\text{DD}} \leq 5.5\text{ V}$ ,  $-40\text{ }^\circ\text{C} \leq T_{\text{A}} \leq 125\text{ }^\circ\text{C}$ ,  $\text{GND} = 0\text{ V}$ , unless otherwise noted. Typical values noted reflect the approximate parameter means at  $T_{\text{A}} = 25\text{ }^\circ\text{C}$  under nominal conditions, unless otherwise noted.

Characteristic	Symbol	Min	Typ	Max	Unit
<b>SPI INTERFACE CHARACTERISTICS<sup>(38)</sup></b>					
Maximum frequency of SPI operation	$f_{\text{SPI}}$	–	–	8.0	MHz
Required low state duration for $\overline{\text{RST}}$ <sup>(39)</sup>	$t_{\text{WRST}}$	10	–	–	$\mu\text{s}$
Rising edge of $\overline{\text{CS}}$ to falling edge of $\overline{\text{CS}}$ (required setup time) <sup>(40)</sup>	$t_{\overline{\text{CS}}}$	–	–	1.0	$\mu\text{s}$
Rising edge of $\overline{\text{RST}}$ to falling edge of $\overline{\text{CS}}$ (required setup time) <sup>(40)</sup>	$t_{\text{ENBL}}$	–	–	5.0	$\mu\text{s}$
Falling edge of $\overline{\text{CS}}$ to rising edge of SCLK (required setup time) <sup>(40)</sup>	$t_{\text{LEAD}}$	–	–	500	ns
Required high state duration of SCLK (required setup time) <sup>(40)</sup>	$t_{\text{WSCLKh}}$	–	–	50	ns
Required low state duration of SCLK (required setup time) <sup>(40)</sup>	$t_{\text{WSCLKl}}$	–	–	50	ns
Falling edge of SCLK to rising edge of $\overline{\text{CS}}$ (required setup time) <sup>(40)</sup>	$t_{\text{LAG}}$	–	–	60	ns
SI to falling edge of SCLK (required setup time) <sup>(41)</sup>	$t_{\text{SI(SU)}}$	–	–	37	ns
Falling edge of SCLK to SI (required setup time) <sup>(41)</sup>	$t_{\text{SI(HOLD)}}$	–	–	49	ns
SO rise time • $C_{\text{L}} = 80\text{ pF}$	$t_{\text{RSO}}$	–	–	13	ns
SO fall time • $C_{\text{L}} = 80\text{ pF}$	$t_{\text{FSO}}$	–	–	13	ns
SI, $\overline{\text{CS}}$ , SCLK, incoming signal rise time <sup>(41)</sup>	$t_{\text{RSI}}$	–	–	13	ns
SI, $\overline{\text{CS}}$ , SCLK, incoming signal fall time <sup>(41)</sup>	$t_{\text{FSI}}$	–	–	13	ns
Time from rising edge of SCLK to SO low-impedance <sup>(42)</sup>	$t_{\text{SO(EN)}}$	–	–	60	ns
Time from rising edge of SCLK to SO high-impedance <sup>(43)</sup>	$t_{\text{SO(DIS)}}$	–	–	60	ns

**Notes**

38. Parameters guaranteed by design.
39.  $\overline{\text{RST}}$  low duration measured with outputs enabled and going to OFF or disabled condition.
40. Maximum setup time required for the 15XS3400 is the minimum guaranteed time needed from the microcontroller.
41. Rise and Fall time of incoming SI,  $\overline{\text{CS}}$ , and SCLK signals suggested for design consideration to prevent the occurrence of double pulsing.
42. Time required for output status data to be available for use at SO. 1.0 k $\Omega$  on pull-up on  $\overline{\text{CS}}$ .
43. Time required for output status data to be terminated at SO. 1.0 k $\Omega$  on pull-up on  $\overline{\text{CS}}$ .

## 5.4 Timing diagrams

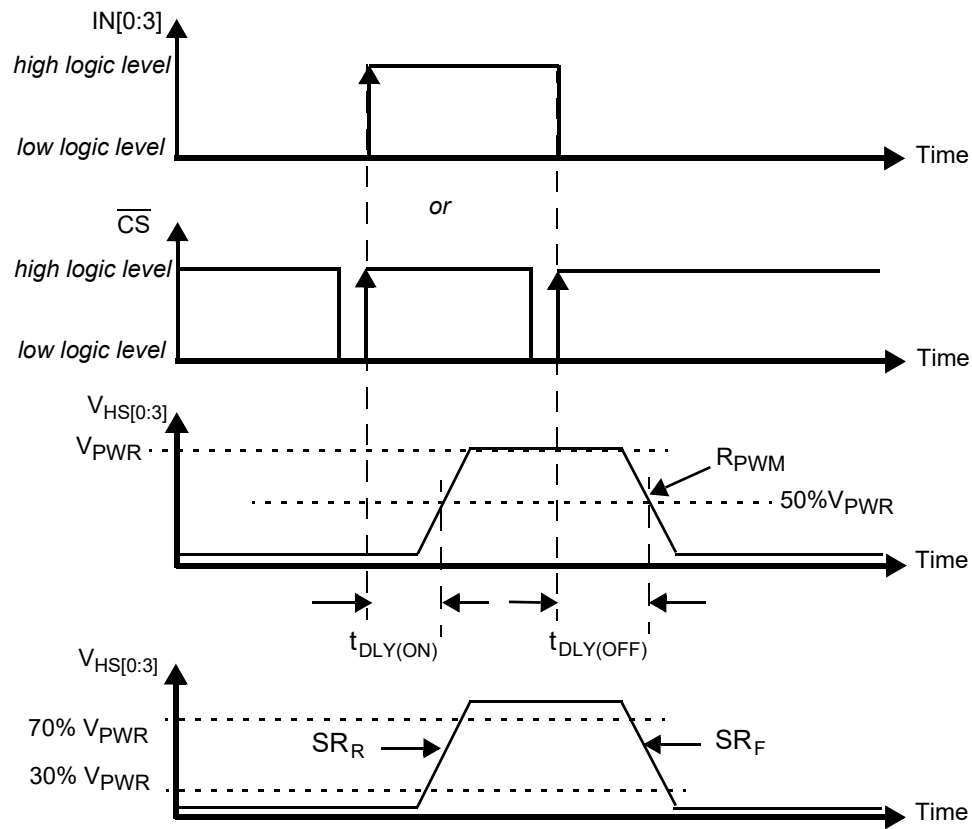

Figure 4. Output slew rate and time delays

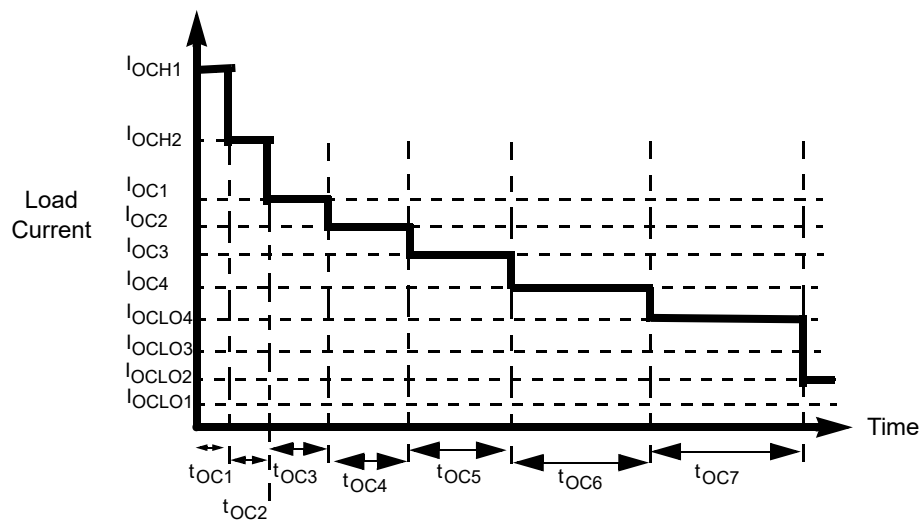

Figure 5. Overcurrent shutdown protection

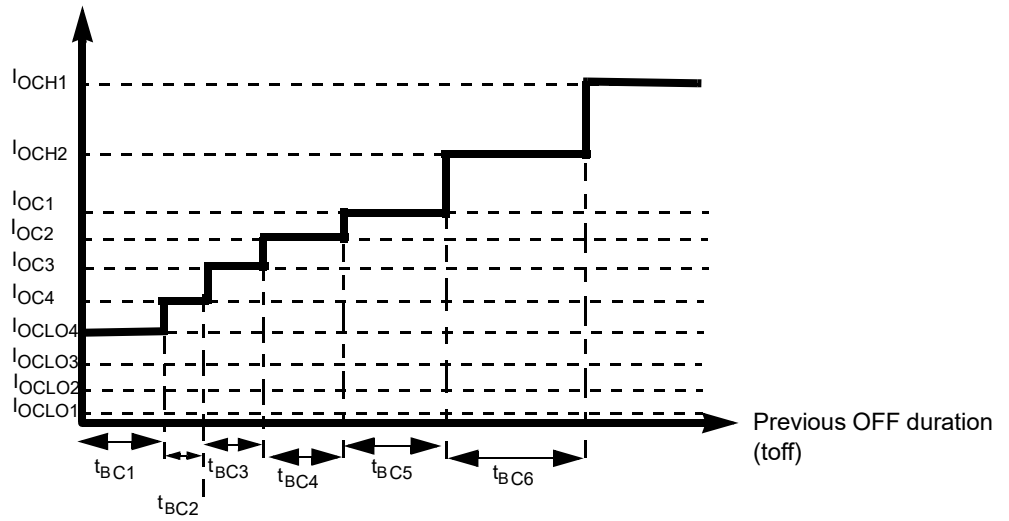

Figure 6. Bulb cooling management

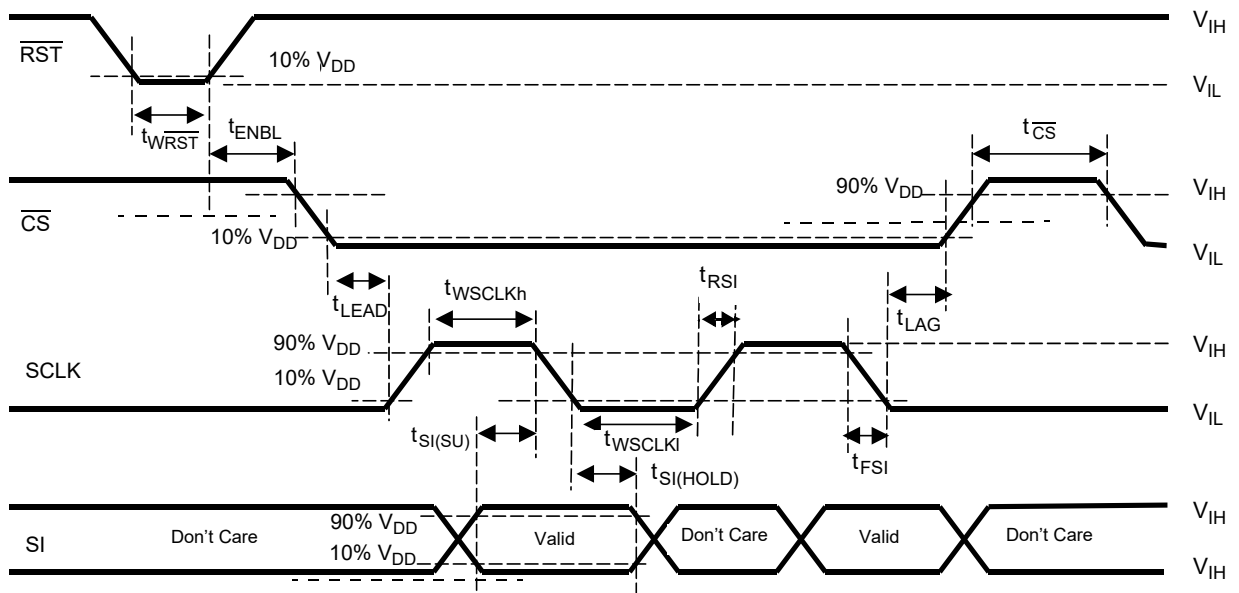
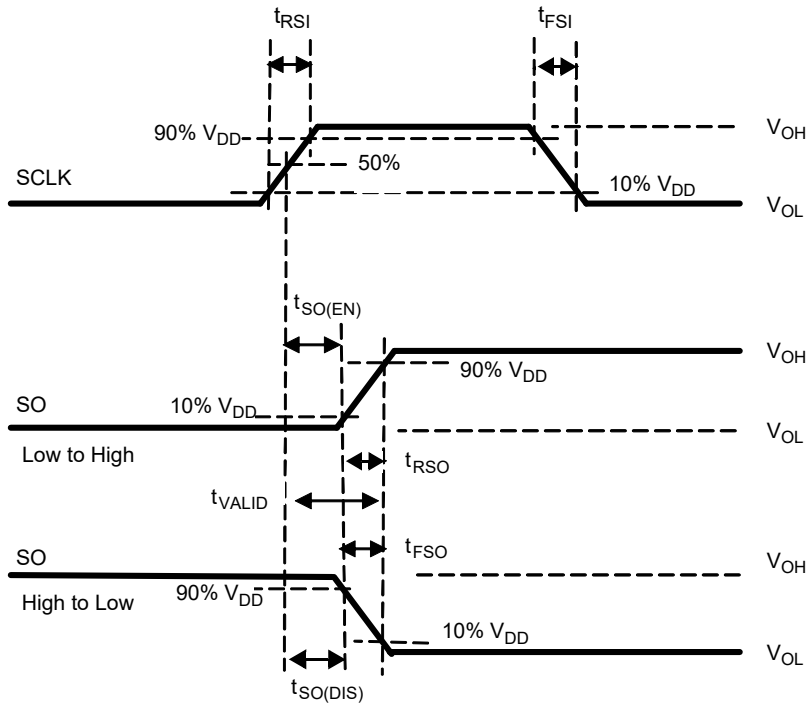

Figure 7. Input timing switching characteristics



**Figure 8. SCLK waveform and valid SO data delay time**

# 6 Functional description

## 6.1 Introduction

The 15XS3400 is one in a family of devices designed for low-voltage automotive lighting applications. Its four low  $R_{DS(on)}$  MOSFETs (quad 15 m $\Omega$ ) can control four separate 55 W/28 W bulbs and/or Xenon modules.

Programming, control and diagnostics are accomplished using a 16-bit SPI interface. Its output with selectable slew-rate improves electromagnetic compatibility (EMC) behavior. Additionally, each output has its own parallel input or SPI control for pulse-width modulation (PWM) control if desired. The 15XS3400 allows the user to program via the SPI the fault current trip levels and duration of acceptable lamp inrush. The device has Fail-safe mode to provide functionality of the outputs in case of MCU damage.

## 6.2 Functional pin description

### 6.2.1 Output current monitoring (CSNS)

The Current Sense pin provides a current proportional to the designated HS0:HS3 output or a voltage proportional to the temperature on the GND flag. That current is fed into a ground-referenced resistor (4.7 k $\Omega$  typical) and its voltage is monitored by an MCU's A/D. The output type is selected via the SPI. This pin can be tri-stated through the SPI.

### 6.2.2 Direct inputs (IN0, IN1, IN2, IN3)

Each IN input wakes the device. The IN0:IN3 high-side input pins are also used to directly control HS0:HS3 high-side output pins. If the outputs are controlled by the PWM module, the external PWM clock is applied to IN0 pin. These pins are to be driven with CMOS levels, and they have a passive internal pull-down,  $R_{DWN}$ .

### 6.2.3 Fault status ( $\overline{FS}$ )

This pin is an open drain configured output requiring an external pull-up resistor to  $V_{DD}$  for fault reporting. If a device fault condition is detected, this pin is active LOW. Specific device diagnostics and faults are reported via the SPI SO pin.

### 6.2.4 Wake

The wake input wakes the device. An internal clamp protects this pin from high damaging voltages with a series resistor (10 k $\Omega$  typ). This input has a passive internal pull-down,  $R_{DWN}$ .

### 6.2.5 Reset ( $\overline{RST}$ )

The reset input wakes the device. This is used to initialize the device configuration and fault registers, as well as place the device in a low-current Sleep mode. The pin also starts the watchdog timer when transitioning from logic [0] to logic [1]. This pin has a passive internal pull-down,  $R_{DWN}$ .

### 6.2.6 Chip select ( $\overline{CS}$ )

The  $\overline{CS}$  pin enables communication with the master microcontroller (MCU). When this pin is in a logic [0] state, the device is capable of transferring information to, and receiving information from, the MCU. The 15XS3400 latches in data from the input shift registers to the addressed registers on the rising edge of  $\overline{CS}$ . The device transfers status information from the power output to the Shift register on the falling edge of  $\overline{CS}$ . The SO output driver is enabled when  $\overline{CS}$  is logic [0].  $\overline{CS}$  should transition from a logic [1] to a logic [0] state only when SCLK is a logic [0].  $\overline{CS}$  has an active internal pull-up from  $V_{DD}$ ,  $I_{UP}$ .

## 6.2.7 Serial clock (SCLK)

The SCLK pin clocks the internal shift registers of the 15XS3400 device. The serial input (SI) pin accepts data into the input shift register on the falling edge of the SCLK signal while the serial output (SO) pin shifts data information out of the SO line driver on the rising edge of the SCLK signal. It is important the SCLK pin be in a logic low state whenever  $\overline{CS}$  makes any transition. For this reason, it is recommended the SCLK pin be in a logic [0] whenever the device is not accessed ( $\overline{CS}$  logic [1] state). SCLK has an active internal pull-down. When  $\overline{CS}$  is logic [1], signals at the SCLK and SI pins are ignored and SO is tri-stated (high-impedance) (see [Figure 10](#), page [27](#)). SCLK input has an active internal pull-down,  $I_{DWN}$ .

## 6.2.8 Serial input (SI)

This is a serial interface (SI) command data input pin. Each SI bit is read on the falling edge of SCLK. A 16-bit stream of serial data is required on the SI pin, starting with D15 (MSB) to D0 (LSB). The internal registers of the 15XS3400 are configured and controlled using a 5-bit addressing scheme described in [Table 11](#), page [37](#). Register addressing and configuration are described in [Table 12](#), page [37](#). SI input has an active internal pull-down,  $I_{DWN}$ .

## 6.2.9 Digital drain voltage (VDD)

This pin is an external voltage input pin used to supply power to the SPI circuit. In the event  $V_{DD}$  is lost ( $V_{DD}$  Failure), the device goes to Fail-safe mode.

## 6.2.10 Ground (GND)

These pins are the ground for the device.

## 6.2.11 Positive power supply (VPWR)

This pin connects to the positive power supply and is the source of operational power for the device. The VPWR contact is the backside surface mount tab of the package.

## 6.2.12 Serial output (SO)

The SO data pin is a tri-stateable output from the shift register. The SO pin remains in a high-impedance state until the  $\overline{CS}$  pin is put into a logic [0] state. The SO data is capable of reporting the status of the output, the device configuration, the state of the key inputs, etc. The SO pin changes state on the rising edge of SCLK and reads out on the falling edge of SCLK. SO reporting descriptions are provided in [Table 24](#), page [43](#).

## 6.2.13 High-side outputs (HS3, HS1, HS0, HS2)

Protected 15 m $\Omega$  high-side power outputs to the load.

## 6.2.14 Fail-safe input (FSI)

This pin incorporates an active internal pull-up current source from internal supply ( $V_{REG}$ ). This enables the watchdog timeout feature. When the FSI pin is opened, the watchdog circuit is enabled. After a watchdog timeout occurs, the output states depends on IN[0:3]. When the FSI pin is connected to GND, the watchdog circuit is disabled. The output states depends on IN[0:3] in case of  $V_{DD}$  failure condition, in case  $V_{DD}$  failure detection is activated ( $VDD\_FAIL\_en$  bit sets to logic [1]).