



Chipsmall Limited consists of a professional team with an average of over 10 year of expertise in the distribution of electronic components. Based in Hongkong, we have already established firm and mutual-benefit business relationships with customers from,Europe,America and south Asia,supplying obsolete and hard-to-find components to meet their specific needs.

With the principle of “Quality Parts,Customers Priority,Honest Operation,and Considerate Service”,our business mainly focus on the distribution of electronic components. Line cards we deal with include Microchip,ALPS,ROHM,Xilinx,Pulse,ON,Everlight and Freescale. Main products comprise IC,Modules,Potentiometer,IC Socket,Relay,Connector.Our parts cover such applications as commercial,industrial, and automotives areas.

We are looking forward to setting up business relationship with you and hope to provide you with the best service and solution. Let us make a better world for our industry!



Contact us

Tel: +86-755-8981 8866 Fax: +86-755-8427 6832

Email & Skype: info@chipsmall.com Web: www.chipsmall.com

Address: A1208, Overseas Decoration Building, #122 Zhenhua RD., Futian, Shenzhen, China



Quad High Side Switch (Quad 35mΩ)

The 33874 is one in a family of devices designed for low-voltage automotive and industrial lighting and motor control applications. Its four low $R_{DS(ON)}$ MOSFETs (four 35mΩ) can control the high sides of four separate resistive or inductive loads.

Programming, control, and diagnostics are accomplished using a 16-bit SPI interface. Additionally, each output has its own parallel input for pulse-width modulation (PWM) control if desired. The 33874 allows the user to program via the SPI the fault current trip levels and duration of acceptable lamp inrush or motor stall intervals. Such programmability allows tight control of fault currents and can protect wiring harnesses and circuit boards as well as loads.

The 33874 is packaged in a power-enhanced 12x12 nonlead Power QFN package with exposed tabs.

Features

- Quad 35mΩ high side switches (at 25°C)
- Operating voltage range of 6.0V to 27V with standby current < 5.0μA
- SPI control of over-current limit, over-current fault blanking time, output OFF open load detection, output ON/OFF control, watchdog timeout, slew rates, and fault status reporting
- SPI status reporting of over-current, open and shorted loads, over-temperature, under-voltage and over-voltage shutdown, fail-safe pin status, and program status
- Analog current feedback with selectable ratio
- Analog board temperature feedback
- Enhanced -16V reverse polarity V_{PWR} protection
- Pb-free packaging designated by suffix code PNA

33874

HIGH SIDE SWITCH

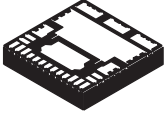

**PNA SUFFIX (PB_FREE)
98ART10510D
24-PIN PQFN (12 x 12)**

ORDERING INFORMATION		
Device	Temperature Range (T _A)	Package
MC33874BPNA/R2	-40°C to 125°C	24 PQFN

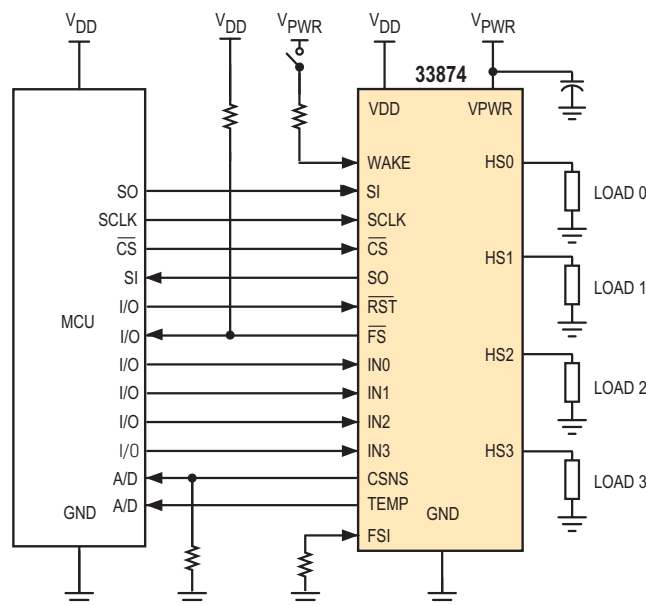

Figure 1. 33874 Simplified Application Diagram

* This document contains certain information on a new product. Specifications and information herein are subject to change without notice.

INTERNAL BLOCK DIAGRAM

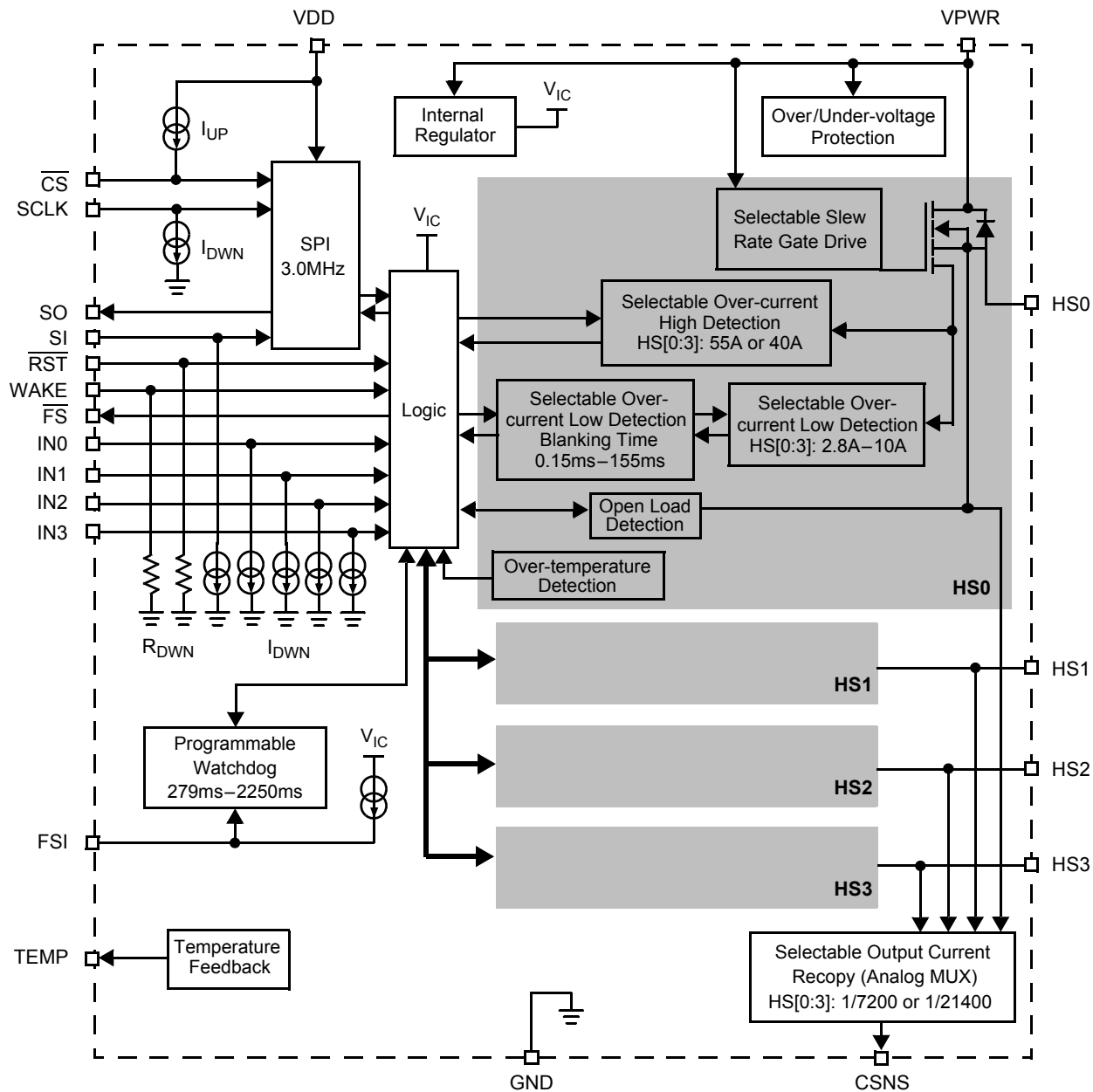

Figure 2. 33874 Simplified Internal Block Diagram

PIN CONNECTIONS

Transparent Top View of Package

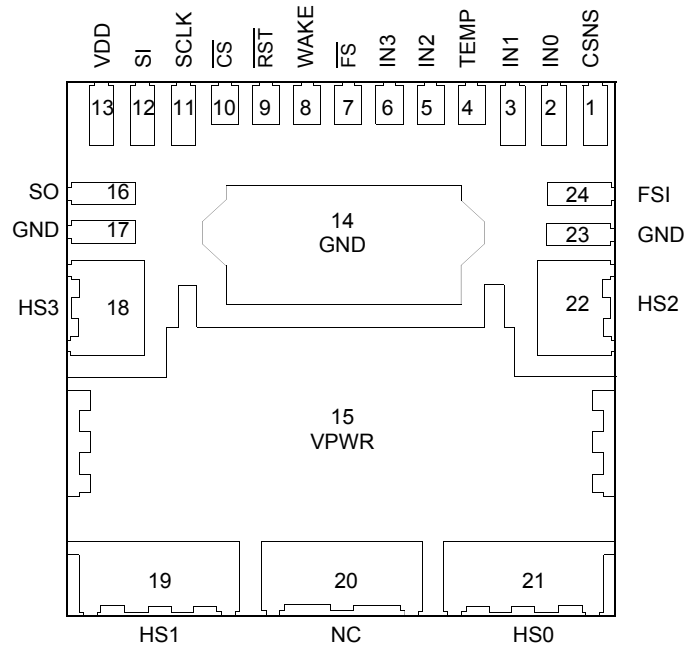

Figure 3. 33874 Pin Connections

Table 1. 33874 Pin Definitions

A functional description of each pin can be found in the Functional Pin Description section beginning on [page 15](#).

Pin Number	Pin Name	Pin Function	Formal Name	Definition
1	CSNS	Output	Output Current Monitoring	The Current Sense pin sources a current proportional to the designated HS0:HS3 output.
2 3 5 6	IN0 IN1 IN2 IN3	Input	Parallel Inputs	The IN0:IN3 high side input pins are used to directly control HS0:HS3 high side output pins, respectively.
4	TEMP	Output	Temperature Feedback	This pin reports an analog value proportional to the temperature of the GND flag (pins 14, 17, 23). It is used by the MCU to monitor board temperature.
7	\overline{FS}	Output	Fault Status (Active Low)	This pin is an open drain configured output requiring an external pull-up resistor to VDD for fault reporting.
8	WAKE	Input	Wake	This input pin controls the device mode and watchdog timeout feature if enabled.
9	\overline{RST}	Input	Reset	This input pin is used to initialize the device configuration and fault registers, as well as place the device in a low-current Sleep Mode.
10	\overline{CS}	Input	Chip Select (Active Low)	This input pin is connected to a chip select output of a master microcontroller (MCU).
11	SCLK	Input	Serial Clock	This input pin is connected to the MCU providing the required bit shift clock for SPI communication.
12	SI	Input	Serial Input	This pin is a command data input pin connected to the SPI Serial Data Output of the MCU or to the SO pin of the previous device of a daisy-chain of devices.
13	VDD	Power	Digital Drain Voltage (Power)	This pin is an external voltage input pin used to supply power to the SPI circuit.

Table 1. 33874 Pin Definitions (continued)

A functional description of each pin can be found in the Functional Pin Description section beginning on [page 15](#).

Pin Number	Pin Name	Pin Function	Formal Name	Definition
14, 17, 23	GND	Ground	Ground	These pins are the ground for the logic and analog circuitry of the device.
15	VPWR	Power	Positive Power Supply	This pin connects to the positive power supply and is the source of operational power for the device.
16	SO	Output	Serial Output	This output pin is connected to the SPI Serial Data Input pin of the MCU or to the SI pin of the next device of a daisy-chain of devices.
18 19 21 22	HS3 HS1 HS0 HS2	Output	High Side Outputs	Protected 35mΩ high side power output pins to the load.
20	NC	N/A	No Connect	This pin may not be connected.
24	FSI	Input	Fail-safe Input	The value of the resistance connected between this pin and ground determines the state of the outputs after a watchdog timeout occurs.

ELECTRICAL CHARACTERISTICS

MAXIMUM RATINGS

Table 2. Maximum Ratings

All voltages are with respect to ground unless otherwise noted. Exceeding these ratings may cause a malfunction or permanent damage to the device.

Ratings	Symbol	Value	Unit
ELECTRICAL RATINGS			
Operating Voltage Range Steady-State	$V_{PWR(SS)}$	-16 to 41	V
V_{DD} Supply Voltage	V_{DD}	-0.3 to 5.5	V
Input/Output Voltage ⁽¹⁾	See note ⁽¹⁾	-0.3 to 7.0	V
SO Output Voltage ⁽¹⁾	V_{SO}	-0.3 to $V_{DD}+0.3$	V
WAKE Input Clamp Current	$I_{CL(WAKE)}$	2.5	mA
CSNS Input Clamp Current	$I_{CL(CSNS)}$	10	mA
HS [0:3] Voltage Positive Negative	V_{HS}	41 -16	V
Output Current ⁽²⁾	$I_{HS[0:3]}$	11	A
Output Clamp Energy ⁽³⁾	$E_{CL[0:3]}$	85	mJ
ESD Voltage ⁽⁴⁾ Human Body Model (HBM) Charge Device Model (CDM) Corner Pins (1, 13, 19, 21) All Other Pins (2-12, 14-18, 20, 22-24)	V_{ESD}	±2000 ±750 ±500	V
THERMAL RATINGS			
Operating Temperature Ambient Junction	T_A T_J	-40 to 125 -40 to 150	°C
Storage Temperature	T_{STG}	-55 to 150	°C
Thermal Resistance ⁽⁵⁾ Junction to Case Junction to Ambient	$R_{\theta JC}$ $R_{\theta JA}$	<1.0 30	°C/W
Peak Pin Reflow Temperature During Solder Mounting ⁽⁶⁾	T_{SOLDER}	Note 6	°C

Notes

- Exceeding voltage limits on IN[0:3], \overline{RST} , FSI, CSNS, TEMP, SI, SO, SCLK, \overline{CS} , or \overline{FS} pins may cause a malfunction or permanent damage to the device.
- Continuous high side output current rating so long as maximum junction temperature is not exceeded. Calculation of maximum output current using package thermal resistance is required.
- Active clamp energy using single-pulse method ($L = 2\text{mH}$, $R_L = 0\Omega$, $V_{PWR} = 14\text{V}$, $T_J = 150^\circ\text{C}$ initial).
- ESD testing is performed in accordance with the Human Body Model ($C_{ZAP} = 100\text{pF}$, $R_{ZAP} = 1500\Omega$), Charge Device Model (CDM), Robotic ($C_{ZAP} = 4.0\text{pF}$).
- Device mounted on a 2s2p test board per JEDEC JESD51-2.
- Freescale's Package Reflow capability meets Sn-Pb-free requirements for JEDEC standard J-STD-020A. For Peak Package Reflow Temperature and Moisture Sensitivity Levels (MSL), Go to www.freescale.com, search by part number [e.g. remove prefixes/suffixes and enter the core ID to view all orderable parts. (i.e. MC33xxx enter 33xxx)], and review parametrics.

STATIC ELECTRICAL CHARACTERISTICS

Table 3. Static Electrical Characteristics

Characteristics noted under conditions $6.0V \leq V_{PWR} \leq 27V$, $4.5V \leq V_{DD} \leq 5.5V$, $-40^{\circ}C \leq T_A \leq 125^{\circ}C$, $GND = 0V$, unless otherwise noted. Typical values noted reflect the approximate parameter means at $T_A = 25^{\circ}C$ under nominal conditions, unless otherwise noted.

Characteristic	Symbol	Min	Typ	Max	Unit
POWER INPUT (VPWR, VDD)					
Battery Supply Voltage Range Fully Operational	V_{PWR}	6.0	–	27	V
V_{PWR} Operating Supply Current Outputs ON, HS[0:3] open	$I_{PWR(ON)}$	–	–	20	mA
V_{PWR} Supply Current Outputs OFF, Open Load Detection Disabled, WAKE > 0.7 x V_{DD} , $RST = V_{LOGIC HIGH}$	$I_{PWR(SBY)}$	–	–	5.0	mA
Sleep State Supply Current ($V_{PWR} = 14V$, $\overline{RST} < 0.5V$, WAKE < 0.5V) $T_A = 25^{\circ}C$ $T_A = 85^{\circ}C$	$I_{PWR(SLEEP)}$	–	1.0	10	μA
		–	–	50	
V_{DD} Supply Voltage	$V_{DD(ON)}$	4.5	5.0	5.5	V
V_{DD} Supply Current No SPI Communication 3.0MHz SPI Communication ⁽⁷⁾	$I_{DD(ON)}$	–	–	1.0	mA
		–	–	5.0	
V_{DD} Sleep State Current	$I_{DD(SLEEP)}$	–	–	5.0	μA
Over-voltage Shutdown Threshold	V_{OV}	28	32	36	V
Over-voltage Shutdown Hysteresis	V_{OVHYS}	0.2	0.8	1.5	V
Under-voltage Shutdown Threshold ⁽⁸⁾	V_{UV}	4.75	5.25	5.75	V
Under-voltage Hysteresis ⁽⁹⁾	V_{UVHYS}	–	0.25	–	V
Under-voltage Power-ON Reset	V_{UVPOR}	–	–	4.75	V

Notes

7. Not guaranteed in production.
8. The under-voltage fault condition is reported to SPI register as long as the external V_{DD} supply is within specification and the V_{PWR} voltage level does not go below the under-voltage Power-ON Reset threshold.
9. This applies when the under-voltage fault is not latched (IN = [0:3]).

Table 3. Static Electrical Characteristics (continued)

Characteristics noted under conditions $6.0V \leq V_{PWR} \leq 27V$, $4.5V \leq V_{DD} \leq 5.5V$, $-40^{\circ}C \leq T_A \leq 125^{\circ}C$, $GND = 0V$, unless otherwise noted. Typical values noted reflect the approximate parameter means at $T_A = 25^{\circ}C$ under nominal conditions, unless otherwise noted.

Characteristic	Symbol	Min	Typ	Max	Unit
OUTPUTS (HS0, HS1, HS2, HS3)					
Output Drain-to-Source ON Resistance ($I_{HS} = 5.0A$, $T_A = 25^{\circ}C$) $V_{PWR} = 6.0V$ $V_{PWR} = 10V$ $V_{PWR} = 13V$	$R_{DS(ON)}$	–	–	55 35 35	$m\Omega$
Output Drain-to-Source ON Resistance ($I_{HS} = 5.0A$, $T_A = 150^{\circ}C$) $V_{PWR} = 6.0V$ $V_{PWR} = 10V$ $V_{PWR} = 13V$	$R_{DS(ON)}$	–	–	94 60 60	$m\Omega$
Output Source-to-Drain ON Resistance ⁽¹⁰⁾ $I_{HS} = 1.0A$, $T_A = 25^{\circ}C$, $V_{PWR} = -12V$	$R_{SD(ON)}$	–	–	70	$m\Omega$
Output Overcurrent High Detection Levels ($9.0V \leq V_{PWR} \leq 16V$) SOCH = 0 SOCH = 1	I_{OCH0} I_{OCH1}	44 32	55 40	66 48	A
Overcurrent Low Detection Levels ($9.0V \leq V_{PWR} \leq 16V$) SOCL[2:0] : 000 SOCL[2:0] : 001 SOCL[2:0] : 010 SOCL[2:0] : 011 SOCL[2:0] : 100 SOCL[2:0] : 101 SOCL[2:0] : 110 SOCL[2:0] : 111	I_{OCL0} I_{OCL1} I_{OCL2} I_{OCL3} I_{OCL4} I_{OCL5} I_{OCL6} I_{OCL7}	8.0 7.1 6.3 5.6 4.6 3.8 3.1 2.2	10 8.9 7.9 7.0 5.8 4.8 3.9 2.8	12 10.7 9.5 8.5 7.0 5.8 4.7 3.4	A
Current Sense Ratio ($9.0V \leq V_{PWR} \leq 16V$, $CSNS \leq 4.5V$) DICR D2 = 0 DICR D2 = 1	C_{SR0} C_{SR1}	– –	1/7200 1/21400	– –	–
Current Sense Ratio (C_{SR0}) Accuracy Output Current 2.0A to 10A	C_{SR0_ACC}	–17	–	17	%

Notes

10. Source-Drain ON Resistance (Reverse Drain-to-Source ON Resistance) with negative polarity V_{PWR} .

Table 3. Static Electrical Characteristics (continued)

Characteristics noted under conditions $6.0V \leq V_{PWR} \leq 27V$, $4.5V \leq V_{DD} \leq 5.5V$, $-40^{\circ}C \leq T_A \leq 125^{\circ}C$, $GND = 0V$, unless otherwise noted. Typical values noted reflect the approximate parameter means at $T_A = 25^{\circ}C$ under nominal conditions, unless otherwise noted.

Characteristic	Symbol	Min	Typ	Max	Unit
OUTPUTS (HS0, HS1, HS2, HS3) (continued)					
Current Sense Ratio (C_{SR1}) Accuracy Output Current 10A to 20A	C_{SR1_ACC}	-19	–	19	%
Current Sense Clamp Voltage CSNS Open; $I_{HS[0:3]} = 11A$	$V_{CL(CSNS)}$	4.5	6.0	7.0	V
Open Load Detection Current ⁽¹¹⁾	I_{OLDC}	30	–	100	μA
Output Fault Detection Threshold Output Programmed OFF	$V_{OFD(THRES)}$	2.0	3.0	4.0	V
Output Negative Clamp Voltage $0.5A \leq I_{HS[0:3]} \leq 2.0A$, Output OFF	V_{CL}	-20	–	-16	V
Over-temperature Shutdown ⁽¹²⁾	T_{SD}	155	175	190	$^{\circ}C$
Over-temperature Shutdown Hysteresis ⁽¹²⁾	$T_{SD(HYS)}$	5.0	–	20	$^{\circ}C$

Notes

- Output OFF Open Load Detection Current is the current required to flow through the load for the purpose of detecting the existence of an open load condition when the specific output is commanded OFF.
- Guaranteed by process monitoring. Not production tested.

Table 3. Static Electrical Characteristics (continued)

Characteristics noted under conditions $6.0V \leq V_{PWR} \leq 27V$, $4.5V \leq V_{DD} \leq 5.5V$, $-40^{\circ}C \leq T_A \leq 125^{\circ}C$, $GND = 0V$, unless otherwise noted. Typical values noted reflect the approximate parameter means at $T_A = 25^{\circ}C$ under nominal conditions, unless otherwise noted.

Characteristic	Symbol	Min	Typ	Max	Unit
CONTROL INTERFACE (SCLK, SI, SO, IN[0:3], \overline{RST}, WAKE, \overline{FS}, \overline{CS}, FSI)					
Input Logic High-voltage ⁽¹³⁾	V_{IH}	$0.7 V_{DD}$	–	–	V
Input Logic Low-voltage ⁽¹³⁾	V_{IL}	–	–	$0.2 V_{DD}$	V
Input Logic Voltage Hysteresis ⁽¹⁴⁾	$V_{IN(HYS)}$	100	850	1200	mV
Input Logic Pull-down Current (SCLK, SI, IN[0:3], $V_{IN} > 0.2 \times V_{DD}$)	I_{DWN}	5.0	–	20	μA
\overline{RST} Input Voltage Range	$V_{\overline{RST}}$	4.5	5.0	5.5	V
SO, \overline{FS} Tri-State Capacitance ⁽¹⁴⁾	C_{SO}	–	–	20	pF
Input Logic Pull-down Resistor (\overline{RST}) and WAKE	R_{DWN}	100	200	400	k Ω
Input Capacitance ⁽¹⁵⁾	C_{IN}	–	4.0	12	pF
Wake Input Clamp Voltage ⁽¹⁶⁾ $I_{CL(WAKE)} < 2.5mA$	$V_{CL(WAKE)}$	7.0	–	14	V
Wake Input Forward Voltage $I_{CL(WAKE)} = -2.5mA$	$V_{F(WAKE)}$	-2.0	–	-0.3	V
SO High-state Output Voltage $I_{OH} = 1.0mA$	V_{SOH}	$0.8 V_{DD}$	–	–	V
\overline{FS} , SO Low-state Output Voltage $I_{OL} = -1.6mA$	V_{SOL}	–	0.2	0.4	V
SO Tri-state Leakage Current $\overline{CS} \geq 0.7 \times V_{DD}$, $0 < V_{SO} < V_{DD}$	$I_{SO(LEAK)}$	-5.0	0	5.0	μA
Input Logic Pull-up Current ⁽¹⁷⁾ \overline{CS} , $V_{IN} < 0.7 \times V_{DD}$	I_{UP}	5.0	–	20	μA
FSI Input pin External Pull-down Resistance ⁽¹⁸⁾ FSI Disabled, HS[0:3] state according to direct inputs state and SPI INx_SPI bits and A/O_s bit FSI Enabled, HS[0:3] OFF FSI Enabled, HS0 ON, HS[1:3] OFF FSI Enabled, HS0 and HS2 ON, HS1 and HS3 OFF	R_{FS}	– 6.0 15 40	0 6.5 17 Infinite	1.0 7.0 19 –	k Ω
Temperature Feedback $T_A = 25^{\circ}C$	T_{FEED}	3.8	3.9	4.0	V
Temperature Feedback Derating	DT_{FEED}	-7.2	-7.5	-7.8	mV/ $^{\circ}C$

Notes

- Upper and lower logic threshold voltage range applies to SI, \overline{CS} , SCLK, \overline{RST} , IN[0:3], and WAKE input signals. The WAKE and \overline{RST} signals may be supplied by a derived voltage referenced to V_{PWR} .
- No hysteresis on FSI and wake pins. Parameter is guaranteed by process monitoring but is not production tested.
- Input capacitance of SI, \overline{CS} , SCLK, \overline{RST} , and WAKE. This parameter is guaranteed by process monitoring but is not production tested.
- The current must be limited by a series resistance when using voltages > 7.0V.
- Pull-up current is with \overline{CS} OPEN. \overline{CS} has an active internal pull-up to VDD.
- The selection of the RFS must take into consideration the tolerance, temperature coefficient and lifetime duration to assure that the resistance value will always be within the desired (specified) range.

DYNAMIC ELECTRICAL CHARACTERISTICS

Table 4. Dynamic Electrical Characteristics

Characteristics noted under conditions $6.0V \leq V_{PWR} \leq 27V$, $4.5V \leq V_{DD} \leq 5.5V$, $-40^{\circ}C \leq T_A \leq 125^{\circ}C$, $GND = 0V$, unless otherwise noted. Typical values noted reflect the approximate parameter means at $T_A = 25^{\circ}C$ under nominal conditions, unless otherwise noted.

Characteristic	Symbol	Min	Typ	Max	Unit
POWER OUTPUT TIMING (HS0, HS1, HS2, HS3)					
Output Rising Slow Slew Rate A (DICR D3 = 0) ⁽¹⁹⁾ 9.0V < V _{PWR} < 16V	SR _{RA_SLOW}	0.1	0.3	0.75	V/μs
Output Rising Slow Slew Rate B (DICR D3 = 0) ⁽²⁰⁾ 9.0V < V _{PWR} < 16V	SR _{RB_SLOW}	0.015	0.05	0.15	V/μs
Output Rising Fast Slew Rate A (DICR D3 = 1) ⁽¹⁹⁾ 9.0V < V _{PWR} < 16V	SR _{RA_FAST}	0.5	1.5	3.0	V/μs
Output Rising Fast Slew Rate B (DICR D3 = 1) ⁽²⁰⁾ 9.0V < V _{PWR} < 16V	SR _{RB_FAST}	0.025	0.3	1.0	V/μs
Output Falling Slow Slew Rate A (DICR D3 = 0) ⁽¹⁹⁾ 9.0V < V _{PWR} < 16V	SR _{FA_SLOW}	0.1	0.3	0.75	V/μs
Output Falling Slow Slew Rate B (DICR D3 = 0) ⁽²⁰⁾ 9.0V < V _{PWR} < 16V	SR _{FB_SLOW}	0.015	0.05	0.15	V/μs
Output Falling Fast Slew Rate A (DICR D3 = 1) ⁽¹⁹⁾ 9.0V < V _{PWR} < 16V	SR _{FA_FAST}	0.5	1.5	3.0	V/μs
Output Falling Fast Slew Rate B (DICR D3 = 1) ⁽²⁰⁾ 9.0V < V _{PWR} < 16V	SR _{FB_FAST}	0.025	0.3	1.0	V/μs
Output Turn-ON Delay Time in Slow Slew Rate ⁽²¹⁾ DICR = 0	t _{DLY_SLOW(ON)}	2.0	30	200	μs
Output Turn-ON Delay Time in Fast Slew Rate ⁽²¹⁾ DICR = 1	t _{DLY_FAST(ON)}	1.0	6.0	100	μs
Output Turn-OFF Delay Time in Slow Slew Rate Mode ⁽²²⁾ DICR = 0	t _{DLY_SLOW(OFF)}	40	200	800	μs
Output Turn-OFF Delay Time in Fast Slew Rate Mode ⁽²²⁾ DICR = 1	t _{DLY_FAST(OFF)}	20	50	400	μs
Over-current Low Detection Blanking Time					ms
OCLT[1:0]: 00	t _{OCL0}	108	155	202	
OCLT[1:0]: 01 ⁽²³⁾	t _{OCL1}	–	–	–	
OCLT[1:0]: 10	t _{OCL2}	55	75	95	
OCLT[1:0]: 11	t _{OCL3}	0.08	0.15	0.3	

Notes

19. Rise and Fall Slew Rates A measured across a 5.0Ω resistive load at high side output = 0.5V to V_{PWR} -3.5V (see [Figure 4](#), page 12). These parameters are guaranteed by process monitoring.
20. Rise and Fall Slew Rates B measured across a 5.0Ω resistive load at high side output = 0.5V to V_{PWR} -3.5V (see [Figure 4](#)). These parameters are guaranteed by process monitoring.
21. Turn-ON delay time measured from rising edge of any signal (IN[0:3], SCLK, \overline{CS}) that would turn the output ON to V_{HS[0:3]} = 0.5V with R_L = 5.0Ω resistive load.
22. Turn-OFF delay time measured from falling edge of any signal (IN[0:3], SCLK, \overline{CS}) that would turn the output OFF to V_{HS[0:3]} = V_{PWR} - 0.5V with R_L = 5.0Ω resistive load.
23. This logical bit is not defined. Do not use.

Table 4. Dynamic Electrical Characteristics (continued)

Characteristics noted under conditions $6.0V \leq V_{PWR} \leq 27V$, $4.5V \leq V_{DD} \leq 5.5V$, $-40^{\circ}C \leq T_A \leq 125^{\circ}C$, $GND = 0V$, unless otherwise noted. Typical values noted reflect the approximate parameter means at $T_A = 25^{\circ}C$ under nominal conditions, unless otherwise noted.

Characteristic	Symbol	Min	Typ	Max	Unit
----------------	--------	-----	-----	-----	------

POWER OUTPUT TIMING (HS0, HS1, HS2, HS3) (continued)

Over-current High Detection Blanking Time	t_{OCH}	1.0	5.0	20	μs
\overline{CS} to CSNS Valid Time ⁽²⁴⁾	t_{CNSVAL}	-	-	10	μs
Watchdog Timeout ⁽²⁵⁾					ms
WD[1:0] : 00	t_{WDTO0}	446	558	725	
WD[1:0] : 01	t_{WDTO1}	223	279	363	
WD[1:0] : 10	t_{WDTO2}	1800	2250	2925	
WD[1:0] : 11	t_{WDTO3}	900	1125	1463	
Direct Input Switching Frequency (DICR D3 = 0)	f_{PWM}	-	300	-	Hz

SPI INTERFACE CHARACTERISTICS (\overline{RST} , \overline{CS} , SCLK, SI, SO)

Maximum Frequency of SPI Operation	f_{SPI}	-	-	3.0	MHz
Required Low-state Duration for \overline{RST} ⁽²⁶⁾	t_{WRST}	-	50	350	ns
Rising Edge of \overline{CS} to Falling Edge of \overline{CS} (Required Setup Time) ⁽²⁷⁾	$t_{\overline{CS}}$	-	-	300	ns
Rising Edge of \overline{RST} to Falling Edge of \overline{CS} (Required Setup Time) ⁽²⁷⁾	t_{ENBL}	-	-	5.0	μs
Falling Edge of \overline{CS} to Rising Edge of SCLK (Required Setup Time) ⁽²⁷⁾	t_{LEAD}	-	50	167	ns
Required High-state Duration of SCLK (Required Setup Time) ⁽²⁷⁾	t_{WSCLKh}	-	-	167	ns
Required Low-state Duration of SCLK (Required Setup Time) ⁽²⁷⁾	t_{WSCLKl}	-	-	167	ns
Falling Edge of SCLK to Rising Edge of \overline{CS} (Required Setup Time) ⁽²⁷⁾	t_{LAG}	-	50	167	ns
SI to Falling Edge of SCLK (Required Setup Time) ⁽²⁸⁾	$t_{SI(SU)}$	-	25	83	ns
Falling Edge of SCLK to SI (Required Setup Time) ⁽²⁸⁾	$t_{SI(HOLD)}$	-	25	83	ns
SO Rise Time $C_L = 200pF$	t_{RSO}	-	25	50	ns
SO Fall Time $C_L = 200pF$	t_{FSO}	-	25	50	ns
SI, \overline{CS} , SCLK, Incoming Signal Rise Time ⁽²⁸⁾	t_{RSI}	-	-	50	ns
SI, \overline{CS} , SCLK, Incoming Signal Fall Time ⁽²⁸⁾	t_{FSI}	-	-	50	ns
Time from Falling Edge of \overline{CS} to SO Low-impedance ⁽²⁹⁾	$t_{SO(EN)}$	-	-	145	ns
Time from Rising Edge of \overline{CS} to SO High-impedance ⁽³⁰⁾	$t_{SO(DIS)}$	-	65	145	ns
Time from Rising Edge of SCLK to SO Data Valid ⁽³¹⁾ $0.2 V_{DD} \leq SO \leq 0.8 \times V_{DD}$, $C_L = 200pF$	t_{VALID}	-	65	105	ns

Notes

24. Time necessary for the CSNS to be with $\pm 5\%$ of the targeted value.
25. Watchdog timeout delay measured from the rising edge of WAKE or \overline{RST} from a sleep state condition, to output turn-ON with the output driven OFF and FSI floating. The values shown are for WDR setting of [00]. The accuracy of t_{WDTO} is consistent for all configured watchdog timeouts.
26. \overline{RST} low duration measured with outputs enabled and going to OFF or disabled condition.
27. Maximum setup time required for the 33874 is the minimum guaranteed time needed from the microcontroller.
28. Rise and Fall time of incoming SI, \overline{CS} , and SCLK signals suggested for design consideration to prevent the occurrence of double pulsing.
29. Time required for output status data to be available for use at SO. 1.0k Ω on pull-up on \overline{CS} .
30. Time required for output status data to be terminated at SO. 1.0k Ω on pull-up on \overline{CS} .
31. Time required to obtain valid data out from SO following the rise of SCLK.

TIMING DIAGRAMS

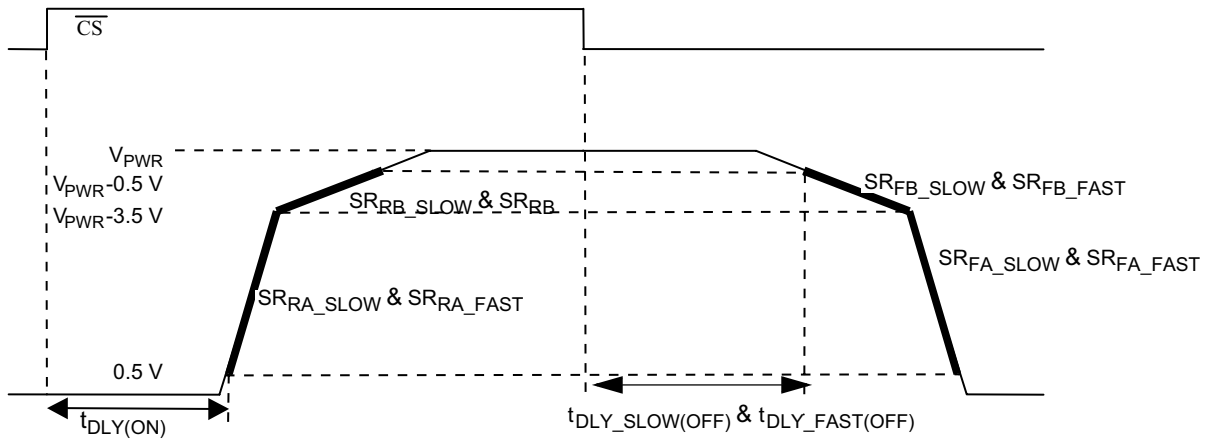

Figure 4. Output Slew Rate and Time Delays

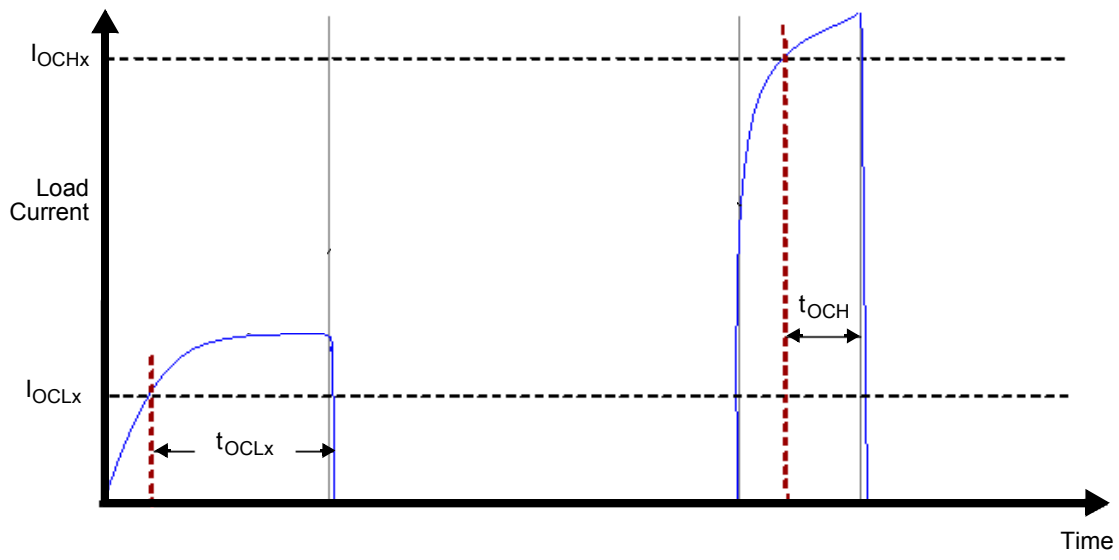

Figure 5. Over-current Shutdown

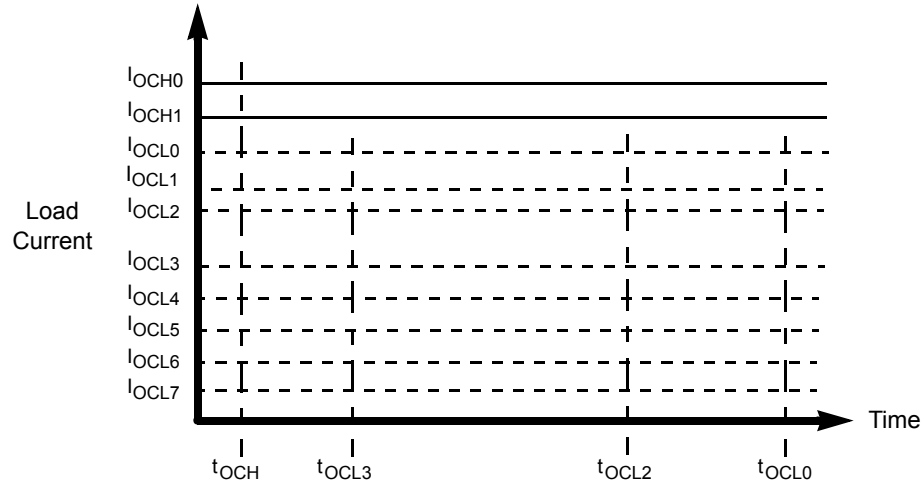

Figure 6. Over-current Low and High Detection

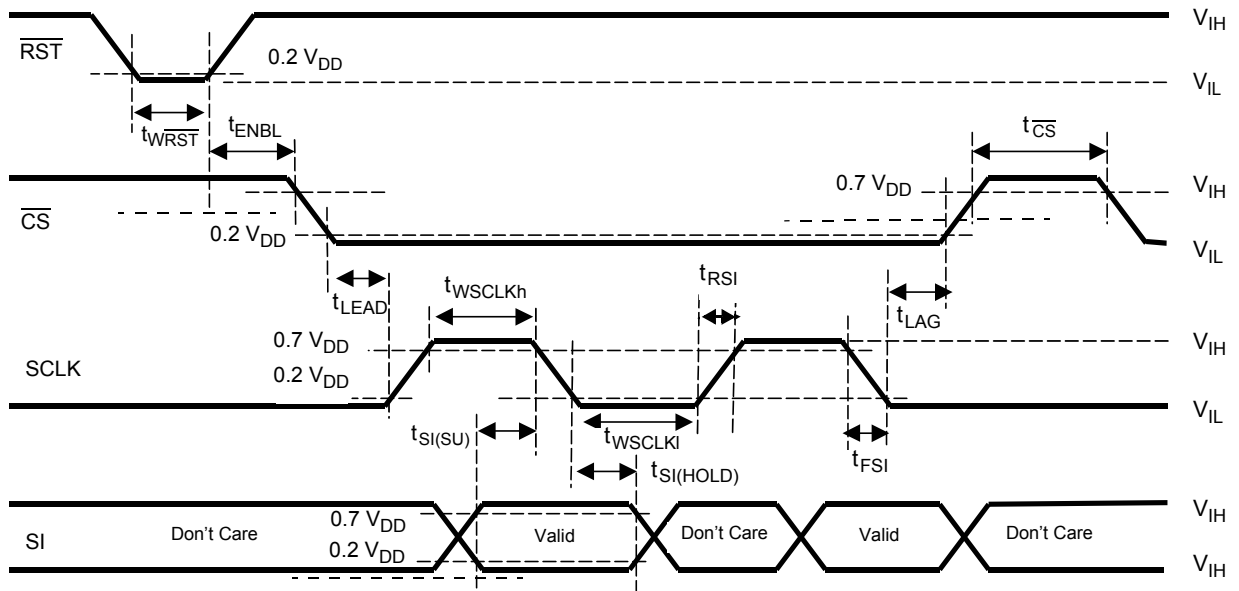

Figure 7. Input Timing Switching Characteristics

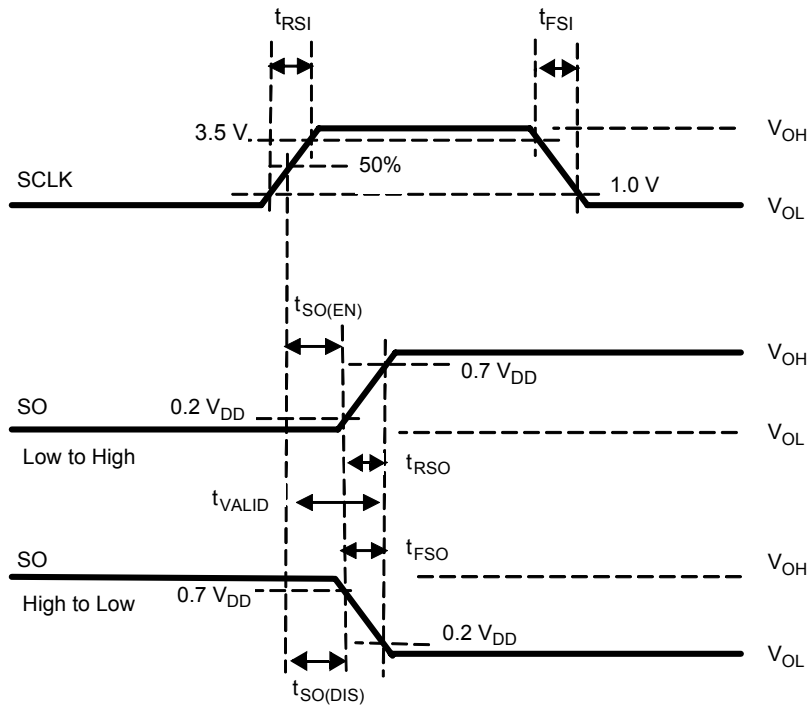

Figure 8. SCLK Waveform and Valid SO Data Delay Time

FUNCTIONAL DESCRIPTION

INTRODUCTION

The 33874 is one in a family of devices designed for low-voltage automotive and industrial lighting and motor control applications. Its four low $R_{DS(ON)}$ MOSFETs (35m Ω) can control the high sides of four separate resistive or inductive loads.

Programming, control, and diagnostics are accomplished using a 16-bit SPI interface. Additionally, each output has its own parallel input for PWM control if desired. The 33874

allows the user to program via the SPI the fault current trip levels and duration of acceptable lamp inrush or motor stall intervals. Such programmability allows tight control of fault currents and can protect wiring harnesses and circuit boards as well as loads.

The 33874 is packaged in a power-enhanced 12 x 12 nonleaded PQFN package with exposed tabs.

FUNCTIONAL PIN DESCRIPTION

OUTPUT CURRENT MONITORING (CSNS)

The Current Sense pin sources a current proportional to the designated HS0:HS3 output. That current is fed into a ground-referenced resistor and its voltage is monitored by an MCU's A/D. The output to be monitored is selected via the SPI. This pin can be tri-stated through the SPI.

SERIAL INPUTS (IN0, IN1, IN2, IN3)

The IN0:IN3 high side input pins are used to directly control HS0:HS3 high side output pins, respectively. A SPI register determines if each input is activated or if the input logic state is ORed or ANDed with the SPI instruction. These pins are to be driven with 5.0V CMOS levels, and they have an active internal pull-down current source.

TEMPERATURE FEEDBACK (TEMP)

This pin reports an analog voltage value proportional to the temperature of the GND. It is used by the MCU to monitor board temperature.

FAULT STATUS (\overline{FS})

This pin is an open drain configured output requiring an external pull-up resistor to V_{DD} for fault reporting. If a device fault condition is detected, this pin is active LOW. Specific device diagnostic faults are reported via the SPI SO pin.

WAKE

This input pin controls the device mode and watchdog timeout feature if enabled. An internal clamp protects this pin from high damaging voltages when the output is current limited with an external resistor. This input has a passive internal pull-down.

RESET (\overline{RST})

This input pin is used to initialize the device configuration and fault registers, as well as place the device in a low-current sleep mode. The pin also starts the watchdog timer

when transitioning from logic [0] to logic [1]. This pin should not be allowed to be logic [1] until V_{DD} is in regulation. This pin has a passive internal pull-down.

CHIP SELECT (\overline{CS})

The \overline{CS} pin enables communication with the master microcontroller (MCU). When this pin is in a logic [0] state, the device is capable of transferring information to, and receiving information from, the MCU. The 33874 latches in data from the Input Shift registers to the addressed registers on the rising edge of \overline{CS} . The device transfers status information from the power output to the Shift register on the falling edge of \overline{CS} . The SO output driver is enabled when \overline{CS} is logic [0]. \overline{CS} should transition from a logic [1] to a logic [0] state only when SCLK is a logic [0]. \overline{CS} has an active internal pull-up, I_{UP} .

SERIAL CLOCK (SCLK)

The SCLK pin clocks the internal shift registers of the 33874 device. The serial input (SI) pin accepts data into the input shift register on the falling edge of the SCLK signal while the serial output (SO) pin shifts data information out of the SO line driver on the rising edge of the SCLK signal. It is important the SCLK pin be in a logic low state whenever \overline{CS} makes any transition. For this reason, it is recommended the SCLK pin be in a logic [0] whenever the device is not accessed (\overline{CS} logic [1] state). SCLK has an active internal pull-down. When \overline{CS} is logic [1], signals at the SCLK and SI pins are ignored and SO is tri-stated (high-impedance) (see [Figure 9](#), page 18).

SERIAL INPUT (SI)

This is a serial interface (SI) command data input pin. Each SI bit is read on the falling edge of SCLK. A 16-bit stream of serial data is required on the SI pin, starting with D15 to D0. The internal registers of the 33874 are configured and controlled using a 5-bit addressing scheme described in [Table 8](#), page 22. Register addressing and configuration are

described in [Table 9](#), page [22](#). The SI input has an active internal pull-down, I_{DWN} .

DIGITAL DRAIN VOLTAGE (VDD)

This pin is an external voltage input pin used to supply power to the SPI circuit. In the event V_{DD} is lost, an internal supply provides power to a portion of the logic, ensuring limited functionality of the device.

GROUND (GND)

This pin is the ground for the device.

POSITIVE POWER SUPPLY (VPWR)

This pin connects to the positive power supply and is the source of operational power for the device. The V_{PWR} contact is the backside surface mount tab of the package.

SERIAL OUTPUT (SO)

The SO data pin is a tri-stateable output from the shift register. The SO pin remains in a high-impedance state until

the \overline{CS} pin is put into a logic [0] state. The SO data is capable of reporting the status of the output, the device configuration, and the state of the key inputs. The SO pin changes state on the rising edge of SCLK and reads out on the falling edge of SCLK. Fault and input status descriptions are provided in [Table 16](#), page [26](#).

HIGH SIDE OUTPUTS (HS3, HS1, HS0, HS2)

Protected 35m Ω high side power output pins to the load.

FAIL-SAFE INPUT (FSI)

The value of the resistance connected between this pin and ground determines the state of the outputs after a watchdog timeout occurs. Depending on the resistance value, either all outputs are OFF or the output HSO only is ON. If the FSI pin is left to float up to a logic [1] level, then the outputs HS0 and HS2 will turn ON when in the Fail-safe state. When the FSI pin is connected to GND, the watchdog circuit and Fail-safe operation are disabled. This pin incorporates an active internal pull-up current source.

FUNCTIONAL INTERNAL BLOCK DESCRIPTION

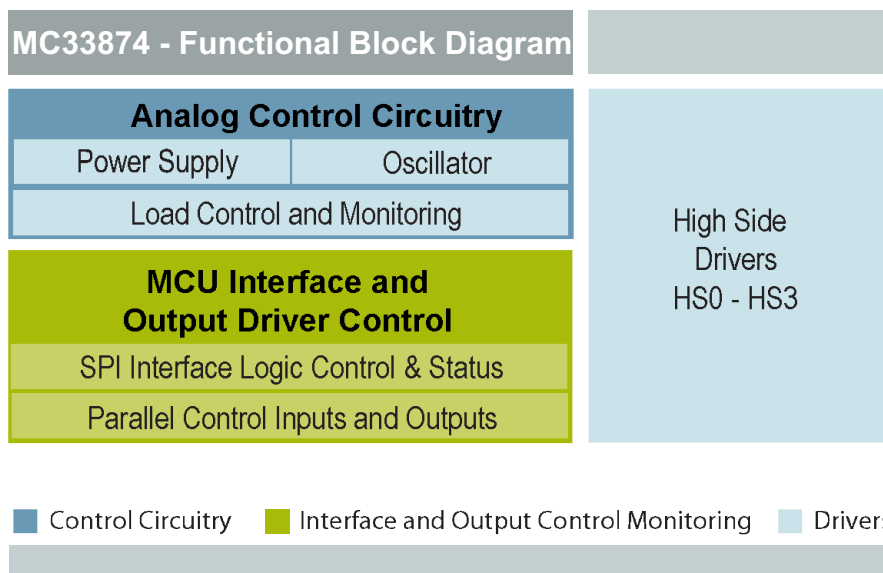

ANALOG CONTROL CIRCUITRY

The 33874 is designed to operate from 6.0V to 27V on the VPWR Pin. The VPWR Pin supplies power to all internal regulators, analog and logic circuit blocks. The VDD supply is used for setting communication threshold levels and supplying power to the SPI interface logic. This IC architecture provides a very low standby current. The analog circuitry provides for over-current and over-temperature protection as well as temperature warning features.

MCU INTERFACE AND OUTPUT CONTROL

The device is designed with 4 inputs for PWM Output driver control, if desired. MCU programming, control and

diagnostics are accomplished using the 16-bit SPI interface. Several parallel control and status lines are provided.

HIGH-SIDE DRIVERS: HS0 – HS3

The 33874 provides high side load drive capability for 4 outputs. The $R_{DS(ON)}$ for the output MOSFETs is 35mΩ. The outputs are protected for over-current and over-temperature. The MOSFET gate drive can be slew rate controlled using the SPI interface. There is also an open load detection feature. A ratioed value of the MOSFET output current is available to the MCU.

The device allows for control of the 4 outputs through the SPI interface or by use of the parallel inputs, which allows for PWM capability.

FUNCTIONAL DEVICE OPERATION

SPI PROTOCOL DESCRIPTION

The SPI interface has a full duplex, three-wire synchronous data transfer with four I/O lines associated with it: Serial Input (SI), Serial Output (SO), Serial Clock (SCLK), and Chip Select (\overline{CS}).

The SI/SO pins of the 33874 follow a first-in first-out (D15 to D0) protocol, with both input and output words transferring the most significant bit (MSB) first. All inputs are compatible with 5.0V CMOS logic levels.

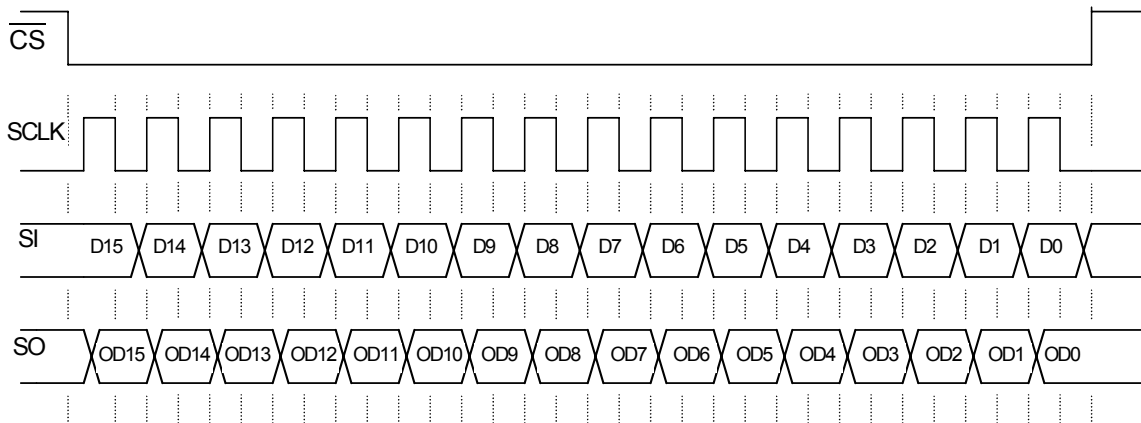

- Notes
1. \overline{RST} is a logic [1] state during the above operation.
 2. D15:D0 relate to the most recent ordered entry of data into the device.
 3. OD15:OD0 relate to the first 16 bits of ordered fault and status data out of the device.

Figure 9. Single 16-Bit Word SPI Communication

OPERATIONAL MODES

The 33874 has four operating modes: Sleep, Normal, Fault, and Fail-safe. [Table 5](#) summarizes details contained in succeeding paragraphs.

Table 5. Fail-Safe Operation and Transitions to Other 33874 Modes

Mode	\overline{FS}	Wake	\overline{RST}	WDTO	Comments
Sleep	x	0	0	x	Device is in Sleep mode. All outputs are OFF
Normal	1	x	1	No	Normal mode. Watchdog is active if enabled.
Fault	0	1	1	No	Device is currently in fault mode. The faulted output(s) is (are) OFF.
	0	1	0		
	0	0	1		
Fail-Safe	1	0	1	Yes	Watchdog has timed out and the device is in Fail-safe Mode. The outputs are as configured with the RFS resistor connected to FSI. \overline{RST} and WAKE must go from logic [1] to logic [0] simultaneously to bring the device out of the Fail-safe mode or momentarily tied the FSI pin to ground.
	1	1	1		
	1	1	0		

x = Don't care.

SLEEP MODE

The Default mode of the 33874 is the Sleep Mode. This is the state of the device after first applying battery voltage (V_{PWR}) prior to any I/O transitions. This is also the state of the device when the WAKE and \overline{RST} are both logic [0]. In the Sleep Mode, the output and all unused internal circuitry, such as the internal 5.0V regulator, are off to minimize current draw. In addition, all SPI-configurable features of the device are as if set to logic [0]. The 33874 will transition to the Normal or Fail-safe operating modes based on the WAKE and \overline{RST} inputs as defined in [Table 5](#).

NORMAL MODE

The 33874 is in Normal Mode when:

- V_{PWR} and V_{DD} are within the normal voltage range.
- \overline{RST} pin is logic [1].
- No fault has occurred.

FAIL-SAFE MODE

FAIL-SAFE MODE AND WATCHDOG

If the FSI input is not grounded, the watchdog timeout detection is active when either the WAKE or \overline{RST} input pin transitions from logic [0] to logic [1]. The WAKE input is capable of being pulled up to V_{PWR} with a series of limiting

resistance limiting the internal clamp current according to the specification.

The Watchdog timeout is a multiple of an internal oscillator and is specified in the [Table 15](#), page 24. As long as the WD bit (D15) of an incoming SPI message is toggled within the minimum watchdog timeout period (WDTO), based on the programmed value of the WDR, the device will operate normally. If an internal watchdog timeout occurs before the WD bit, the device will revert to a Fail-safe mode until the device is reinitialized.

During the Fail-safe Mode, the outputs will be ON or OFF depending upon the resistor RFS connected to the FSI pin, regardless of the state of the various direct inputs and modes ([Table 6](#)).

Table 6. Output State During Fail-safe Mode

RFS (kΩ)	High Side State
0 (shorted to ground)	Fail-safe Mode Disabled
6.0	All HS OFF
15	HS0 ON HS1:HS3 OFF
30 (open)	HS0 and HS2 ON HS1 and HS3 OFF

In the Fail-safe Mode, the SPI register content is retained except for over-current high and low detection levels, timing and latched over-temperature which are reset to their default value (SOCL, SOCH, and OCTL and OT_latch_[0:3] bits). Then the watchdog, over-voltage, over-temperature, and over-current circuitry (with default value) are fully operational.

The Fail-safe Mode can be detected by monitoring the WDTO bit D2 of the WD register. This bit is logic [1] when the device is in Fail-safe Mode. The device can be brought out of the Fail-safe Mode by transitioning the WAKE and RST pins from logic [1] to logic [0] or forcing the FSI pin to logic [0].

[Table 5](#) summarizes the various methods for resetting the device from the latched Fail-safe Mode.

If the FSI pin is tied to GND, the Watchdog fail-safe operation is disabled.

LOSS OF V_{DD}

If the external 5.0 V supply is not within specification, or even disconnected, all register content is reset. The outputs can still be driven by the direct inputs IN0:IN3. The 33874 uses the battery input to power the output MOSFET-related current sense circuitry and any other internal logic providing fail-safe device operation with no V_{DD} supplied. In this state, the watchdog, under-voltage, over-voltage, over-temperature (latched) and over-current circuitry are fully operational with default values.

FAULT MODE

This 33874 indicates the faults below as they occur by driving the \overline{FS} pin to logic [0]:

- Over-temperature fault
- Over-voltage and under-voltage fault
- Open load fault
- Over-current fault (high and low)

The \overline{FS} pin will automatically return to logic [1] when the fault condition is removed, except for overcurrent, overtemperature (in case of latching configuration) and in some cases of undervoltage.

The \overline{FS} pin reports all faults. For latched faults, this pin is reset by a new Switch ON command (via the SPI or direct input IN).

Fault information is retained in the fault register and is available (and reset) via the SO pin during the first valid SPI communication (refer to [Table 17](#), page 26).

PROTECTION AND DIAGNOSTIC FEATURES

OVER-TEMPERATURE FAULT (LATCHING OR NON-LATCHING)

The 33874 incorporates over-temperature detection and shutdown circuitry for each output structure.

The over-temperature is latched per default and can be unlatched through SPI with $\overline{OT_latch}_{[0:3]}$ bits.

An over-temperature fault condition results in turning OFF the corresponding output. To remove the fault and be able to turn ON again the outputs, the failure must be removed and:

- in Normal Mode: the corresponding output must be commanded OFF and ON again in case of over-temperature latched ($\overline{OT_latch}$ bit = 0).
- in Normal Mode: the corresponding output turns ON automatically if the temperature is below $T_{SD}-T_{SD(HYS)}$ in case of unlatched over-temperature ($\overline{OT_latch}$ bit = 1).

- in Fail-safe Mode: the FSI input must be grounded and then set to its nominal voltage to switch ON the outputs.

The over-temperature fault (one for each output) is reported by SPI. If the over-temperature is latched, the SPI reports $OTF_s = [1]$ and $OCLF_s = [1]$. In case of non-latched, $OTF_s = [1]$ only is reported.

The fault bits will be cleared in the status register after either a valid SPI read command or a power on reset of the device.

OVERCURRENT FAULT (LATCHING)

The 33874 has eight programmable over-current low detection levels (I_{OCL}) and two programmable over-current high detection levels (I_{OCH}) for maximum device protection. The two selectable, simultaneously active over-current

detection levels, defined by I_{OCH} and I_{OCL} , are illustrated in [Figure 6](#), page 13. The eight different over-current low detect levels (I_{OCL0} : I_{OCL7}) are illustrated in [Figure 6](#).

If the load current level ever reaches the selected over-current low detection level and the over-current condition exceeds the programmed over-current time period (t_{OCX}), the device will latch the output OFF.

If at any time the current reaches the selected I_{OCH} level, then the device will immediately latch the fault and turn OFF the output, regardless of the selected t_{OCH} driver.

For both cases, the device output will stay off indefinitely until the device is commanded OFF and then ON again.

OVER-VOLTAGE FAULT (NON-LATCHING)

The 33874 shuts down the output during an over-voltage fault (OVF) condition on the VPWR pin. The output remains in the OFF state until the over-voltage condition is removed. When experiencing this fault, the OVF fault bit is set in the bit D1 and cleared after either a valid SPI read or a power reset of the device.

The over-voltage protection can be disabled through SPI (bit OV_DIS). When disabled, the returned SO bit OD13 still reflects any over-voltage condition (over-voltage warning).

UNDER-VOLTAGE SHUTDOWN (LATCHING OR NON-LATCHING)

The output(s) will latch off at some battery voltage below 6.0 V. As long as the V_{DD} level stays within the normal specified range, the internal logic states within the device will be sustained.

In the case where battery voltage drops below the under-voltage threshold (V_{PWRUV}) output will turn off, \overline{FS} will go to logic 0, and the fault register UVF bit will be set to 1.

Two cases need to be considered when the battery level recovers :

- If outputs command are low, \overline{FS} will go to logic 1 but the UVF bit will remain set to 1 until the next read operation (warning report).
- If the output command is ON, then \overline{FS} will remain at logic 0. The output must be turned OFF and ON again to re-enable the state of output and release \overline{FS} . The UVF bit will remain set to 1 until the next read operation.

The under-voltage protection can be disabled through SPI (bit UV_dis = 1). In this case, the \overline{FS} does not report any under-voltage fault condition, UVF bit is set to 1, and the output state is not changed as long as the battery voltage does not drop any lower than 2.5 V.

The daisy chain feature is available under VDD in nominal conditions.

Table 7. Device behavior in case of Under-voltage

Quad High Side Switch (VPWR Battery Voltage)**	State	UV Enable IN[0:3] = 0 (Falling VPWR)	UV Enable IN[0:3] = 0 (Rising VPWR)	UV Enable IN_x*** = 1 (Falling VPWR)	UV Enable IN_x*** = 1 (Rising VPWR)	UV Disable IN[0:3] = 0 (Falling or Rising VPWR)	UV Disable IN_x*** = 1 (Falling or Rising VPWR)
VPWR > VPWRUV	Output State	OFF	OFF	ON	OFF	OFF	ON
	\overline{FS} State	1	1	1	0	1	1
	SPI Fault Register UVF Bit	0	1 until next read	0	1	0 (falling) 1 until next read (rising)	0 (falling) 1 until next read (rising)
VPWRUV > VPWR > UVPOR	Output State	OFF	OFF	OFF	OFF	OFF	ON
	\overline{FS} State	0	0	0	0	1	1
	SPI Fault Register UVF Bit	1	1	1	1	1	1
UVPOR > VPWR > 2.5V*	Output State	OFF	OFF	OFF	OFF	OFF	ON
	\overline{FS} State	1	1	1	1	1	1
	SPI Fault Register UVF Bit	1 until next read	1 until next read	1 until next read	1 until next read	1 until next read	1 until next read
2.5V > VPWR > 0V	Output State	OFF	OFF	OFF	OFF	OFF	OFF
	\overline{FS} State	1	1	1	1	1	1
	SPI Fault Register UVF Bit	1 until next read	1 until next read	1 until next read	1 until next read	1 until next read	1 until next read
	Comments	UV fault is not latched	UV fault is not latched		UV fault is latched		

* = Typical value; not guaranteed

** = While V_{DD} remains within specified range.

*** = IN_x is equivalent to IN_x direct input or IN_spi_s SPI input.

OPEN LOAD FAULT (NON-LATCHING)

The 33874 incorporates open load detection circuitry on the output. Output open load fault (OLF) is detected and reported as a fault condition when the output is disabled (OFF). The open load fault is detected and latched into the status register after the internal gate voltage is pulled low enough to turn OFF the output. The OLF fault bit is set in the status register. If the open load fault is removed, the status register will be cleared after reading the register.

The open load protection can be disabled through SPI (bit OL_DIS). It is recommended to disable open load circuitry in case of a permanent disconnected load.

REVERSE BATTERY

The output survives the application of reverse voltage as low as -16V. Under these conditions, the output's gate is

enhanced to keep the junction temperature less than 150°C. The ON resistance of the output is fairly similar to that in the Normal mode. No additional passive components are required except on VDD.

GROUND DISCONNECT PROTECTION

In the event the 33874 ground is disconnected from load ground, the device protects itself and safely turns OFF the output regardless of the state of the output at the time of disconnection. A 10KΩ resistor needs to be added between the wake pin and the rest of the circuitry in order to ensure that the device turns off in case of ground disconnect and to prevent this pin to exceed its maximum ratings.

Current limit resistors in the digital input lines protect the digital supply against excessive current (10kΩ typical).

LOGIC COMMANDS AND REGISTERS

SERIAL INPUT COMMUNICATION

SPI communication is accomplished using 16-bit messages. A message is transmitted by the MCU starting with the MSB D15 and ending with the LSB, D0 (Table 8). Each incoming command message on the SI pin can be interpreted using the following bit assignments: the MSB, D15, is the watchdog bit. In some cases, output selection is done with bits D12:D11. The next three bits, D10:D8, are used to select the command register. The remaining five bits,

D4:D0, are used to configure and control the outputs and their protection features.

Multiple messages can be transmitted in succession to accommodate those applications where daisy-chaining is desirable, or to confirm transmitted data, as long as the messages are all multiples of 16 bits. Any attempt made to latch in a message that is not 16 bits will be ignored.

The 33874 has defined registers, which are used to configure the device and to control the state of the outputs. Table 9, page 22, summarizes the SI registers.

Table 8. SI Message Bit Assignment

Bit Sig	SI Msg Bit	Message Bit Description
MSB	D15	Watchdog in: toggled to satisfy watchdog requirements.
	D14:D15	Not used.
	D12:D11	Register address bits used in some cases for output selection.
	D10:D8	Register address bits.
	D7:D5	Not used.
	D4:D1	Used to configure the inputs, outputs, and the device protection features and SO status content.
LSB	D0	Used to configure the inputs, outputs, and the device protection features and SO status content.

Table 9. Serial Input Address and Configuration Bit Map

SI Register	SI Data															
	D15	D14	D13	D12	D11	D10	D9	D8	D7	D6	D5	D4	D3	D2	D1	D0
STATR_s	WDIN	0	0	0	0	0	0	0	0	0	0	SOA4	SOA3	SOA2	SOA1	SOA0
OCR0	WDIN	0	0	0	0	0	0	1	0	0	0	0	IN3_SPI	IN2_SPI	IN1_SPI	IN0_SPI
OCR1	WDIN	0	0	0	1	0	0	1	0	0	0	0	CSNS3_EN	CSNS2_EN	CSNS1_EN	CSNS0_EN
SOCHLR_s	WDIN	0	0	A ₁	A ₀	0	1	0	0	0	0	0	SOCH_s	SOCL2_s	SOCL1_s	SOCL0_s
CDTOLR_s	WDIN	0	0	A ₁	A ₀	0	1	1	0	0	0	0	OL_DIS_s	OCL_DIS_s	OCLT1_s	OCLT0_s
DICR_s	WDIN	0	0	A ₁	A ₀	1	0	0	0	0	0	0	FAST_SR_s	CSNS_high_s	DIR_DIS_s	A/O_s
UOVR	WDIN	0	0	0	0	1	0	1	0	0	0	0	OT_latch-1	OT_latch_0	UV_DIS	OV_DIS
WDR	WDIN	0	0	0	1	1	0	1	0	0	0	0	OT_latch_3	OT_latch_2	WD1	WD0
NAR	WDIN	0	0	0	0	1	1	0	0	0	0	0	No Action (Allow Toggling of D15-WDIN)			
RESET	0	0	0	X	X	X	X	X	0	0	0	0	0	0	0	0

x=Don't care.

s=Output selection with the bits A₁A₀ as defined in Table 10.

D15 is used to toggle watchdog event (WDIN)

DEVICE REGISTER ADDRESSING

The following section describes the possible register addresses and their impact on device operation.

ADDRESS 00000—STATUS REGISTER (STATR_S)

The STATR register is used to read the device status and the various configuration register contents without disrupting the device operation or the register contents. The register bits D[4:0] determine the content of the first sixteen bits of SO data. In addition to the device status, this feature provides the ability to read the content of the OCR0, OCR1, SOCHLR,

CDTOLR, DICR, UOVR, WDR, and NAR registers. (Refer to the section entitled [Serial Output Communication \(Device Status Return Data\)](#) beginning on page [24](#).)

ADDRESS 00001—OUTPUT CONTROL REGISTER (OCR0)

The OCR0 register allows the MCU to control the ON/OFF state of four outputs through the SPI. Incoming message bit D3:D0 reflects the desired states of the four high side outputs (INx_SPI), respectively. A logic [1] enables the corresponding output switch and a logic [0] turns it OFF.

ADDRESS 01001—OUTPUT CONTROL REGISTER (OCR1)

Incoming message bits D3:D0 reflect the desired output that will be mirrored on the Current Sense (CSNS) pin. A logic [1] on message bits D3:D0 enables the CSNS pin for outputs HS3:HS0, respectively. In the event the current sense is enabled for multiple outputs, the current will be summed. In the event that bits D3:D0 are all logic [0], the output CSNS will be tri-stated. This is useful when several CSNS pins of several devices share the same A/D converter.

ADDRESS A₁A₀010—SELECT OVER-CURRENT HIGH AND LOW REGISTER (SOCHLR_S)

The SOCHLR_s register allows the MCU to configure the output over-current low and high detection levels, respectively. Each output “s” is independently selected for configuration based on the state of the D12:D11 bits ([Table 10](#)).

Table 10. Output Selection

A ₁ (D12)	A ₀ (D11)	HS_s
0	0	HS0
0	1	HS1
1	0	HS2
1	1	HS3

Each output can be configured to different levels. In addition to protecting the device, this slow blow fuse emulation feature can be used to optimize the load requirements matching system characteristics. Bits D2:D0 set the over-current low detection level to one of eight possible levels, as shown in [Table 11](#), page [23](#). Bit D3 sets the over-current high detection level to one of two levels, as outlined in [Table 12](#), page [23](#).

Table 11. Over-current Low Detection Levels

SOCL2_s* (D2)	SOCL1_s* (D1)	SOCL0_s* (D0)	Over-current Low Detection (Amperes)
			HS0 to HS3
0	0	0	10
0	0	1	8.9
0	1	0	7.9
0	1	1	7.0
1	0	0	5.8
1	0	1	4.8
1	1	0	3.9
1	1	1	2.8

* “_s” refers to the output, which is selected through bits D12:D11; refer to [Table 10](#), page [23](#).

Table 12. Over-current High Detection Levels

SOCH_s* (D3)	Over-current High Detection (Amperes)
	HS0 to HS3
0	55
1	40

* “_s” refers to the output, which is selected through bits D12:D11; refer to [Table 10](#), page [23](#).

ADDRESS A₁A₀011—CURRENT DETECTION TIME AND OPEN LOAD REGISTER (CDTOLR)

The CDTOLR register is used by the MCU to determine the amount of time the device will allow an over-current low condition before an output latches OFF. Each output is independently selected for configuration based on A₁A₀, which are the state of the D12:D11 bits (refer to [Table 10](#), page [23](#)).

Bits D1:D0 (OCLT1_s:OCLT0_s) allow the MCU to select one of three over-current fault blanking times defined in [Table 13](#). Note that these timeouts apply only to the over-current low detection levels. If the selected over-current high level is reached, the device will latch off within 20μs.

Table 13. Over-current Low Detection Blanking Time

OCLT[1:0]_s*	Timing
00	155ms
01	Do not use
10	75ms
11	150μs

* “_s” refers to the output, which is selected through bits D12:D11; refer to [Table 10](#), page [23](#).

A logic [1] on bit D2 (OCL_DIS_s) disables the over-current low detection feature. When disabled, there is no timeout for the selected output and the over-current low detection feature is disabled.

A logic [1] on bit D3 (OL_DIS_s) disables the open load (OL) detection feature for the output corresponding to the state of bits D12:D11.

ADDRESS A₁A₀100—DIRECT INPUT CONTROL REGISTER (DICR)

The DICR register is used by the MCU to enable, disable, or configure the direct IN pin control of each output. Each output is independently selected for configuration based on the state bits D12:D11 (refer to [Table 10](#), page [23](#)).

For the selected output, a logic [0] on bit D1 (DIR_DIS_s) will enable the output for direct control. A logic [1] on bit D1 will disable the output from direct control.

While addressing this register, if the Input was enabled for direct control, a logic [1] for the D0 (A/O_s) bit will result in a Boolean AND of the IN pin with its corresponding IN_SPI D[4:0] message bit when addressing OCR0. Similarly, a logic [0] on the D0 pin results in a Boolean OR of the IN pin to the corresponding message bits when addressing the OCR0. This register is especially useful if several loads are required to be independently PWM controlled. For example, the IN pins of several devices can be configured to operate all of the outputs with one PWM output from the MCU. If each output is then configured to be Boolean ANDed to its respective IN pin, each output can be individually turned OFF by SPI while controlling all of the outputs, commanded on with the single PWM output.

A logic [1] on bit D2 (CSNS_high_s) is used to select the high ratio on the CSNS pin for the selected output. The default value [0] is used to select the low ratio ([Table 14](#)).

Table 14. Current Sense Ratio

CSNS_high_s* (D2)	Current Sense Ratio
	HS0 to HS3
0	1/7200
1	1/21400

* “_s” refers to the output, which is selected through bits D12:D11; refer to [Table 10](#), page [23](#).

A logic [1] on bit D3 (FAST_SR_s) is used to select the high speed slew rate for the selected output, the default value [0] corresponds to the low speed slew rate.

ADDRESS 00101—UNDER-VOLTAGE/OVER-VOLTAGE AND HS[0,1] OVER-TEMPERATURE REGISTER (UOVR)

The UOVR register disables the under-voltage (D1) and/or over-voltage (D0) protection. When these two bits are [0], the under and over-voltages are active (default value).

The UOVR register allows the over-temperature detection latching on the HS0 and HS1. To latch the over-temperature, the bits (OT_latch_1 and OT_latch_0) must be set to [0] which is the default value. To disable the latching, both bits must be set to [1].

ADDRESS 01101—WATCHDOG AND HS[2,3] OVER-TEMPERATURE REGISTER (WDR)

The WDR register is used by the MCU to configure the watchdog timeout. The watchdog timeout is configured using bits D1 and D0. When D1 and D0 bits are programmed for the desired watchdog timeout period ([Table 15](#)), the WDSPI bit should be toggled as well, ensuring the new timeout period is programmed at the beginning of a new count sequence.

The WDR register allows the over-temperature detection latching on the HS2 and HS3. To latch the over-temperature, the bits (OT_latch_3 and OT_latch_2) must be set to [0] which is the default value. To disable the latching, both bits must be set to [1].

Table 15. Watchdog Timeout

WD[1:0] (D1, D0)	Timing (ms)
00	558
01	279
10	2250
11	1125

ADDRESS 00110—NO ACTION REGISTER (NAR)

The NAR register can be used to no-operation fill SPI data packets in a daisy-chain SPI configuration. This would allow devices to be unaffected by commands being clocked over a daisy-chained SPI configuration. By toggling the WD bit (D15) the watchdog circuitry would continue to be reset while no programming or data read back functions are being requested from the device.

SERIAL OUTPUT COMMUNICATION (DEVICE STATUS RETURN DATA)

When the \overline{CS} pin is pulled low, the output register is loaded. Meanwhile, the data is clocked out MSB- (OD15-) first as the new message data is clocked into the SI pin. The first sixteen bits of data clocking out of the SO, and following a \overline{CS} transition, is dependent upon the previously written SPI word.

Any bits clocked out of the Serial Output (SO) pin after the first 16 bits will be representative of the initial message bits clocked into the SI pin since the \overline{CS} pin first transitioned to a logic [0]. This feature is useful for daisy-chaining devices as well as message verification.

A valid message length is determined following a \overline{CS} transition of [0] to [1]. If there is a valid message length, the data is latched into the appropriate registers. A valid message length is a multiple of 16 bits. At this time, the SO pin is tri-stated and the fault status register is now able to accept new fault status information.

SO data will represent information ranging from fault status to register contents, user selected by writing to the STATR bits OD4, OD3, OD2, OD1, and OD0. The value of the previous bits SOA4 and SOA3 will determine which output the SO information applies to for the registers which are output specific; viz., Fault, SOCHLR, CDTOLR, and DICR registers.

Note that the SO data will continue to reflect the information for each output (depending on the previous OD4, OD3 state) that was selected during the most recent STATR write until changed with an updated STATR write.

The output status register correctly reflects the status of the STATR-selected register data at the time that the \overline{CS} is pulled to a logic [0] during SPI communication, and/or for the period of time since the last valid SPI communication, with the following exceptions:

- The previous SPI communication was determined to be invalid. In this case, the status will be reported as though the invalid SPI communication never occurred.

- Battery transients below 6.0V resulting in an under-voltage shutdown of the outputs may result in incorrect data loaded into the status register. The SO data transmitted to the MCU during the first SPI communication following an under-voltage V_{PWR} condition should be ignored.
- The \overline{RST} pin transition from a logic [0] to [1] while the WAKE pin is at logic [0] may result in incorrect data loaded into the Status register. The SO data transmitted to the MCU during the first SPI communication following this condition should be ignored.

SERIAL OUTPUT BIT ASSIGNMENT

The 16 bits of serial output data depend on the previous serial input message, as explained in the following paragraphs. [Table 16](#), page [26](#), summarizes SO returned data for bits OD15:OD0.

- Bit OD15 is the MSB; it reflects the state of the watchdog bit from the previously clocked-in message.
- Bit OD14 remains logic [0] except when an under-voltage condition occurred.
- Bit OD13 remains logic [0] except when an over-voltage condition occurred.
- Bits OD12:OD8 reflect the state of the bits SOA4:SOA0 from the previously clocked in message.
- Bits OD7:OD4 give the fault status flag of the outputs HS3:HS0, respectively.
- The contents of bits OD3:OD0 depend on bits D4:D0 from the most recent STATR command SOA4:SOA0 as explained in the paragraphs following [Table 16](#).