



Chipsmall Limited consists of a professional team with an average of over 10 year of expertise in the distribution of electronic components. Based in Hongkong, we have already established firm and mutual-benefit business relationships with customers from,Europe,America and south Asia,supplying obsolete and hard-to-find components to meet their specific needs.

With the principle of "Quality Parts,Customers Priority,Honest Operation,and Considerate Service",our business mainly focus on the distribution of electronic components. Line cards we deal with include Microchip,ALPS,ROHM,Xilinx,Pulse,ON,Everlight and Freescale. Main products comprise IC,Modules,Potentiometer,IC Socket,Relay,Connector.Our parts cover such applications as commercial,industrial, and automotives areas.

We are looking forward to setting up business relationship with you and hope to provide you with the best service and solution. Let us make a better world for our industry!



Contact us

Tel: +86-755-8981 8866 Fax: +86-755-8427 6832

Email & Skype: info@chipsmall.com Web: www.chipsmall.com

Address: A1208, Overseas Decoration Building, #122 Zhenhua RD., Futian, Shenzhen, China



MC34063A, MC33063A, SC34063A, SC33063A, NCV33063A



ON Semiconductor®

www.onsemi.com

1.5 A, Step-Up/Down/ Inverting Switching Regulators

The MC34063A Series is a monolithic control circuit containing the primary functions required for DC-to-DC converters. These devices consist of an internal temperature compensated reference, comparator, controlled duty cycle oscillator with an active current limit circuit, driver and high current output switch. This series was specifically designed to be incorporated in Step-Down and Step-Up and Voltage-Inverting applications with a minimum number of external components. Refer to Application Notes AN920A/D and AN954/D for additional design information.

Features

- Operation from 3.0 V to 40 V Input
- Low Standby Current
- Current Limiting
- Output Switch Current to 1.5 A
- Output Voltage Adjustable
- Frequency Operation to 100 kHz
- Precision 2% Reference
- NCV Prefix for Automotive and Other Applications Requiring Unique Site and Control Change Requirements; AEC-Q100 Qualified and PPAP Capable
- These Devices are Pb-Free, Halogen Free/BFR Free and are RoHS Compliant

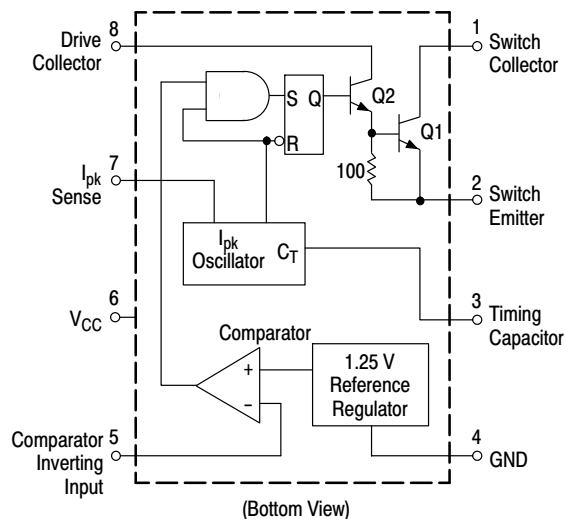

This device contains 79 active transistors.

Figure 1. Representative Schematic Diagram

MARKING DIAGRAMS



SOIC-8
D SUFFIX
CASE 751

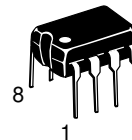
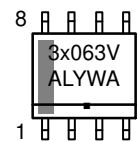
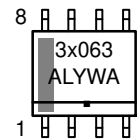

PDIP-8
P, P1 SUFFIX
CASE 626

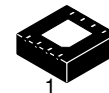
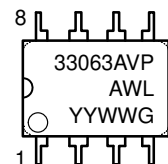
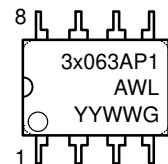

DFN8
CASE 488AF

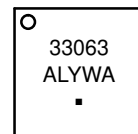

- x = 3 or 4
- A = Assembly Location
- L, WL = Wafer Lot
- Y, YY = Year
- W, WW = Work Week
- G or ■ = Pb-Free Package

ORDERING INFORMATION

See detailed ordering and shipping information in the package dimensions section on page 12 of this data sheet.

MC34063A, MC33063A, SC34063A, SC33063A, NCV33063A

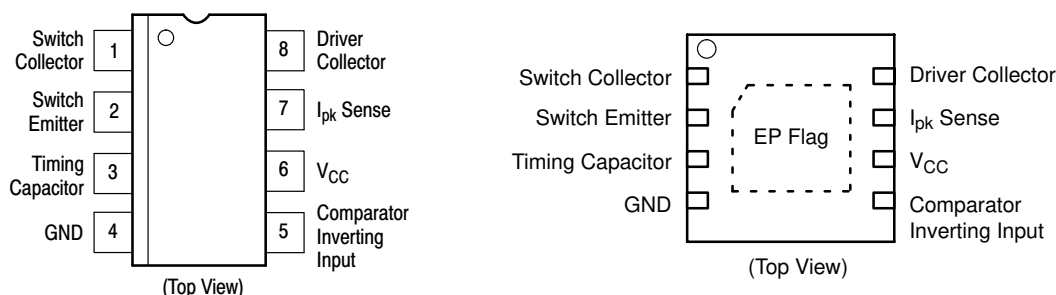

Figure 2. Pin Connections

MAXIMUM RATINGS

Rating	Symbol	Value	Unit
Power Supply Voltage	V_{CC}	40	Vdc
Comparator Input Voltage Range	V_{IR}	-0.3 to +40	Vdc
Switch Collector Voltage	$V_{C(switch)}$	40	Vdc
Switch Emitter Voltage ($V_{Pin\ 1} = 40\ V$)	$V_{E(switch)}$	40	Vdc
Switch Collector to Emitter Voltage	$V_{CE(switch)}$	40	Vdc
Driver Collector Voltage	$V_{C(driver)}$	40	Vdc
Driver Collector Current (Note 1)	$I_{C(driver)}$	100	mA
Switch Current	I_{SW}	1.5	A
Power Dissipation and Thermal Characteristics			
Plastic Package, P, P1 Suffix			
$T_A = 25^\circ\text{C}$	P_D	1.25	W
Thermal Resistance	$R_{\theta JA}$	115	$^\circ\text{C/W}$
SOIC Package, D Suffix			
$T_A = 25^\circ\text{C}$	P_D	625	mW
Thermal Resistance	$R_{\theta JA}$	160	$^\circ\text{C/W}$
Thermal Resistance	$R_{\theta JC}$	45	$^\circ\text{C/W}$
DFN Package			
$T_A = 25^\circ\text{C}$	P_D	1.25	mW
Thermal Resistance	$R_{\theta JA}$	80	$^\circ\text{C/W}$
Operating Junction Temperature	T_J	+150	$^\circ\text{C}$
Operating Ambient Temperature Range	T_A		$^\circ\text{C}$
MC34063A, SC34063A		0 to +70	
MC33063AV, NCV33063A		-40 to +125	
MC33063A, SC33063A		-40 to +85	
Storage Temperature Range	T_{stg}	-65 to +150	$^\circ\text{C}$

Stresses exceeding those listed in the Maximum Ratings table may damage the device. If any of these limits are exceeded, device functionality should not be assumed, damage may occur and reliability may be affected.

1. Maximum package power dissipation limits must be observed.
2. This device series contains ESD protection and exceeds the following tests: Human Body Model 4000 V per MIL-STD-883, Method 3015. Machine Model Method 400 V.
3. NCV prefix is for automotive and other applications requiring site and change control.

MC34063A, MC33063A, SC34063A, SC33063A, NCV33063A

ELECTRICAL CHARACTERISTICS ($V_{CC} = 5.0\text{ V}$, $T_A = T_{low}$ to T_{high} [Note 4], unless otherwise specified.)

Characteristics	Symbol	Min	Typ	Max	Unit
-----------------	--------	-----	-----	-----	------

OSCILLATOR

Frequency ($V_{Pin\ 5} = 0\text{ V}$, $C_T = 1.0\text{ nF}$, $T_A = 25^\circ\text{C}$)	f_{osc}	24	33	42	kHz
Charge Current ($V_{CC} = 5.0\text{ V to }40\text{ V}$, $T_A = 25^\circ\text{C}$)	I_{chg}	24	35	42	μA
Discharge Current ($V_{CC} = 5.0\text{ V to }40\text{ V}$, $T_A = 25^\circ\text{C}$)	I_{dischg}	140	220	260	μA
Discharge to Charge Current Ratio (Pin 7 to V_{CC} , $T_A = 25^\circ\text{C}$)	I_{dischg}/I_{chg}	5.2	6.5	7.5	–
Current Limit Sense Voltage ($I_{chg} = I_{dischg}$, $T_A = 25^\circ\text{C}$)	$V_{ipk(sense)}$	250	300	350	mV

OUTPUT SWITCH (Note 5)

Saturation Voltage, Darlington Connection ($I_{SW} = 1.0\text{ A}$, Pins 1, 8 connected)	$V_{CE(sat)}$	–	1.0	1.3	V
Saturation Voltage (Note 6) ($I_{SW} = 1.0\text{ A}$, $R_{Pin\ 8} = 82\ \Omega$ to V_{CC} , Forced $\beta \approx 20$)	$V_{CE(sat)}$	–	0.45	0.7	V
DC Current Gain ($I_{SW} = 1.0\text{ A}$, $V_{CE} = 5.0\text{ V}$, $T_A = 25^\circ\text{C}$)	h_{FE}	50	75	–	–
Collector Off–State Current ($V_{CE} = 40\text{ V}$)	$I_{C(off)}$	–	0.01	100	μA

COMPARATOR

Threshold Voltage $T_A = 25^\circ\text{C}$ $T_A = T_{low}$ to T_{high}	V_{th}	1.225 1.21	1.25 –	1.275 1.29	V
Threshold Voltage Line Regulation ($V_{CC} = 3.0\text{ V to }40\text{ V}$) MC33063, MC34063 MC33063V, NCV33063	Reg_{line}	– –	1.4 1.4	5.0 6.0	mV
Input Bias Current ($V_{in} = 0\text{ V}$)	I_{IB}	–	–20	–400	nA

TOTAL DEVICE

Supply Current ($V_{CC} = 5.0\text{ V to }40\text{ V}$, $C_T = 1.0\text{ nF}$, Pin 7 = V_{CC} , $V_{Pin\ 5} > V_{th}$, Pin 2 = GND, remaining pins open)	I_{CC}	–	–	4.0	mA
--	----------	---	---	-----	----

Product parametric performance is indicated in the Electrical Characteristics for the listed test conditions, unless otherwise noted. Product performance may not be indicated by the Electrical Characteristics if operated under different conditions.

- $T_{low} = 0^\circ\text{C}$ for MC34063, SC34063; -40°C for MC33063, SC33063, MC33063V, NCV33063
 $T_{high} = +70^\circ\text{C}$ for MC34063, SC34063; $+85^\circ\text{C}$ for MC33063, SC33063; $+125^\circ\text{C}$ for MC33063V, NCV33063
- Low duty cycle pulse techniques are used during test to maintain junction temperature as close to ambient temperature as possible.
- If the output switch is driven into hard saturation (non–Darlington configuration) at low switch currents ($\leq 300\text{ mA}$) and high driver currents ($\geq 30\text{ mA}$), it may take up to $2.0\ \mu\text{s}$ for it to come out of saturation. This condition will shorten the off time at frequencies $\geq 30\text{ kHz}$, and is magnified at high temperatures. This condition does not occur with a Darlington configuration, since the output switch cannot saturate. If a non–Darlington configuration is used, the following output drive condition is recommended:

$$\text{Forced } \beta \text{ of output switch : } \frac{I_{C \text{ output}}}{I_{C \text{ driver}} - 7.0\text{ mA}} \geq 10$$

* The $100\ \Omega$ resistor in the emitter of the driver device requires about 7.0 mA before the output switch conducts.

MC34063A, MC33063A, SC34063A, SC33063A, NCV33063A

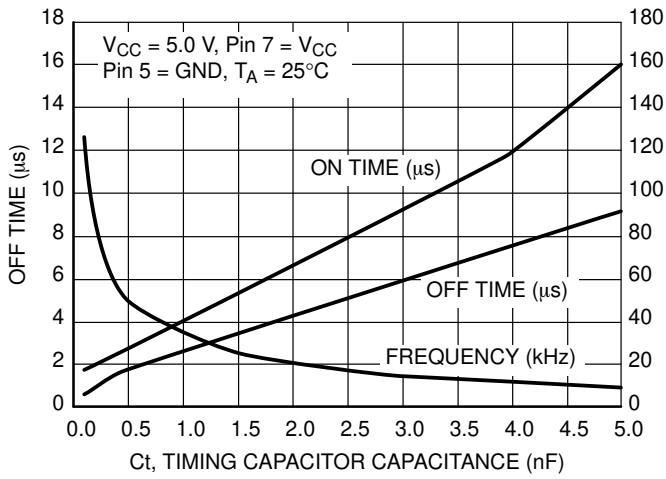

Figure 3. Oscillator Frequency

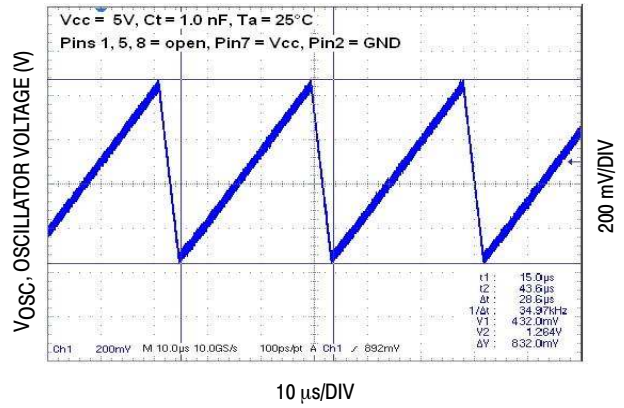

Figure 4. Timing Capacitor Waveform

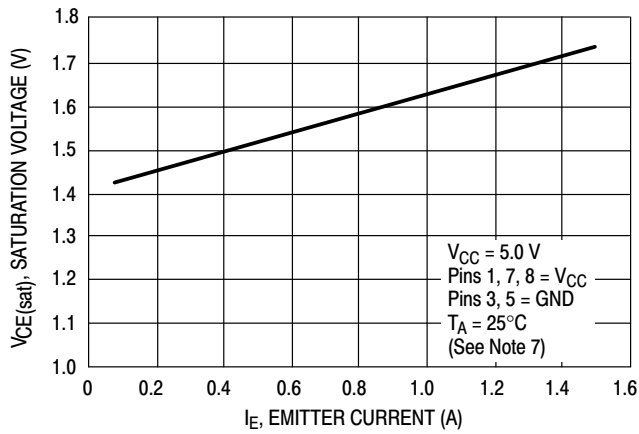

Figure 5. Emitter Follower Configuration Output Saturation Voltage versus Emitter Current

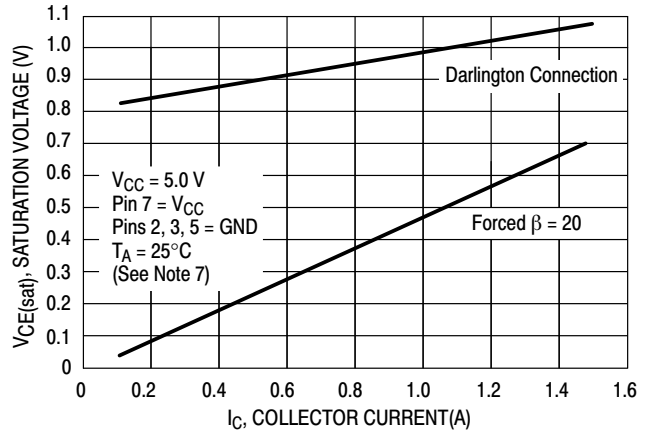

Figure 6. Common Emitter Configuration Output Switch Saturation Voltage versus Collector Current

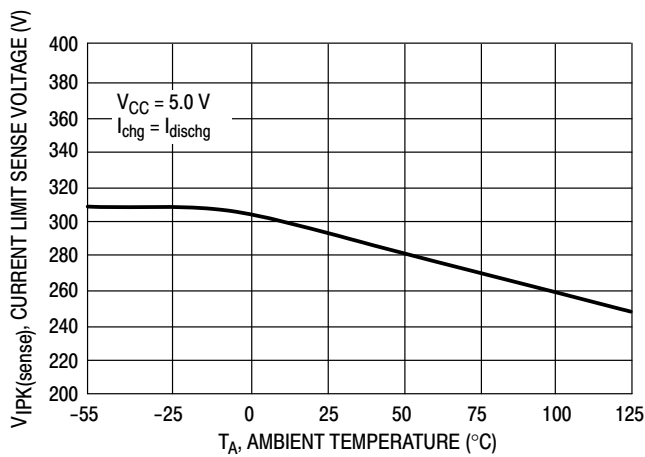

Figure 7. Current Limit Sense Voltage versus Temperature

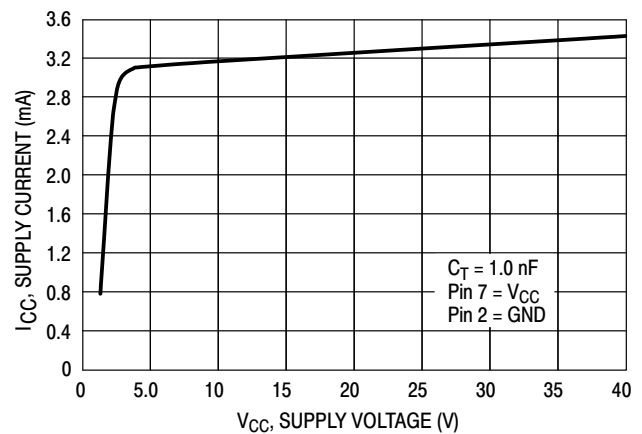
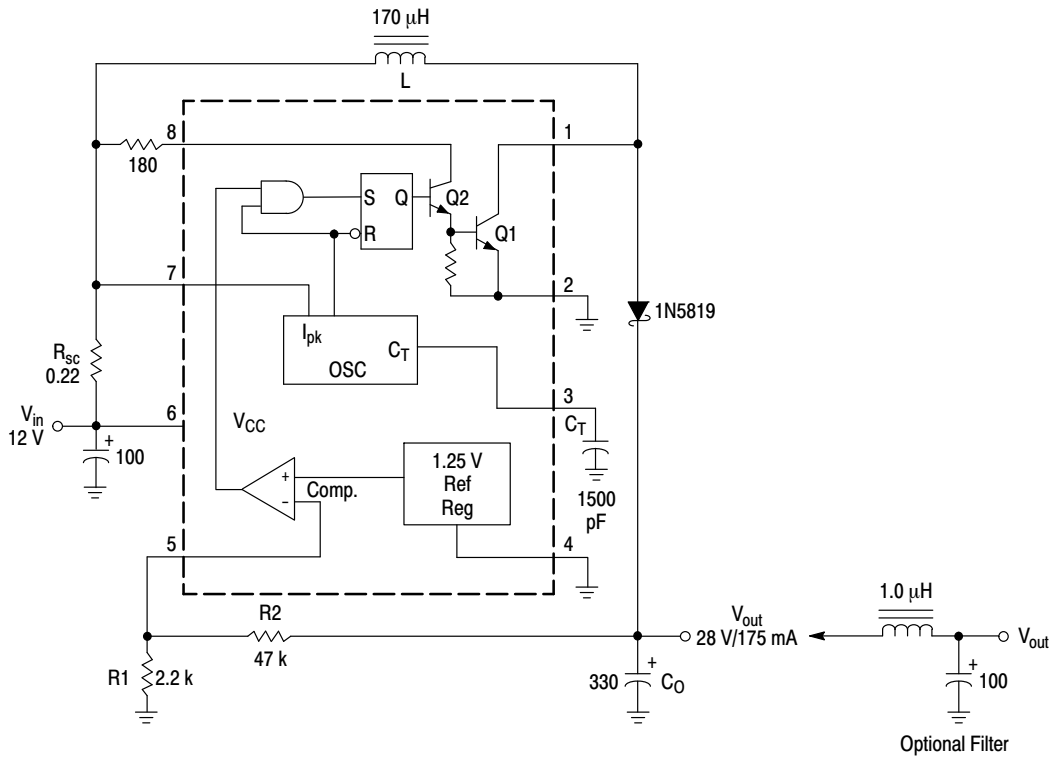

Figure 8. Standby Supply Current versus Supply Voltage

7. Low duty cycle pulse techniques are used during test to maintain junction temperature as close to ambient temperature as possible.



Test	Conditions	Results
Line Regulation	$V_{in} = 8.0 \text{ V to } 16 \text{ V}, I_O = 175 \text{ mA}$	$30 \text{ mV} = \pm 0.05\%$
Load Regulation	$V_{in} = 12 \text{ V}, I_O = 75 \text{ mA to } 175 \text{ mA}$	$10 \text{ mV} = \pm 0.017\%$
Output Ripple	$V_{in} = 12 \text{ V}, I_O = 175 \text{ mA}$	400 mVpp
Efficiency	$V_{in} = 12 \text{ V}, I_O = 175 \text{ mA}$	87.7%
Output Ripple With Optional Filter	$V_{in} = 12 \text{ V}, I_O = 175 \text{ mA}$	40 mVpp

Figure 9. Step-Up Converter

MC34063A, MC33063A, SC34063A, SC33063A, NCV33063A

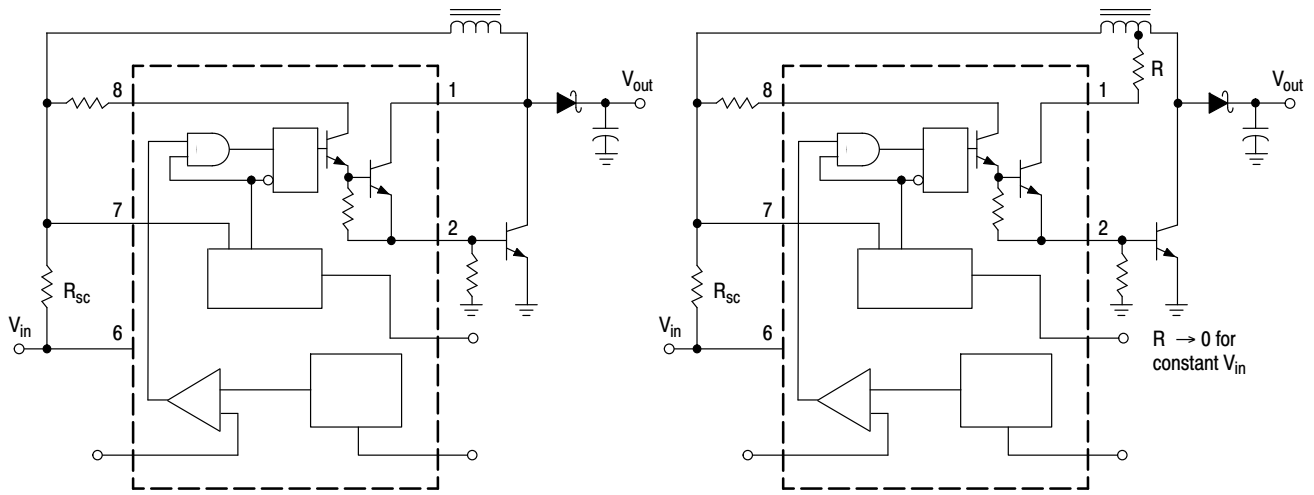

Figure 10. External Current Boost Connections for I_C Peak Greater than 1.5 A

9a. External NPN Switch

9b. External NPN Saturated Switch

(See Note 8)

8. If the output switch is driven into hard saturation (non-Darlington configuration) at low switch currents (≤ 300 mA) and high driver currents (≥ 30 mA), it may take up to $2.0 \mu\text{s}$ to come out of saturation. This condition will shorten the off time at frequencies ≥ 30 kHz, and is magnified at high temperatures. This condition does not occur with a Darlington configuration, since the output switch cannot saturate. If a non-Darlington configuration is used, the following output drive condition is recommended.

MC34063A, MC33063A, SC34063A, SC33063A, NCV33063A

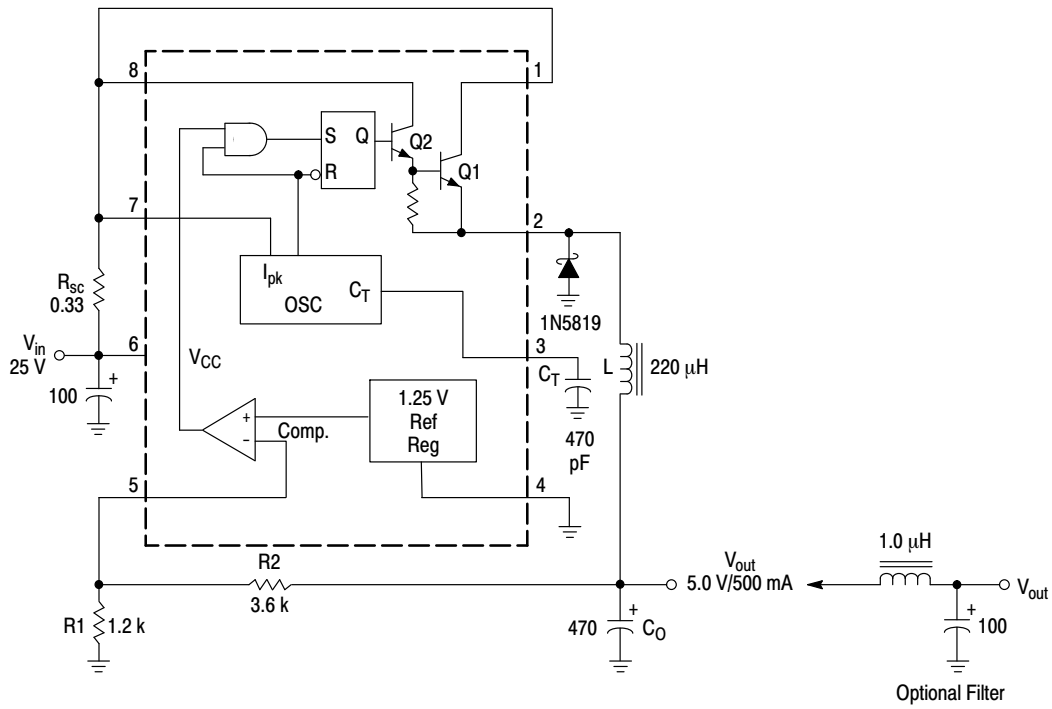

Test	Conditions	Results
Line Regulation	$V_{in} = 15 \text{ V to } 25 \text{ V}, I_O = 500 \text{ mA}$	$12 \text{ mV} = \pm 0.12\%$
Load Regulation	$V_{in} = 25 \text{ V}, I_O = 50 \text{ mA to } 500 \text{ mA}$	$3.0 \text{ mV} = \pm 0.03\%$
Output Ripple	$V_{in} = 25 \text{ V}, I_O = 500 \text{ mA}$	120 mVpp
Short Circuit Current	$V_{in} = 25 \text{ V}, R_L = 0.1 \Omega$	1.1 A
Efficiency	$V_{in} = 25 \text{ V}, I_O = 500 \text{ mA}$	83.7%
Output Ripple With Optional Filter	$V_{in} = 25 \text{ V}, I_O = 500 \text{ mA}$	40 mVpp

Figure 11. Step-Down Converter

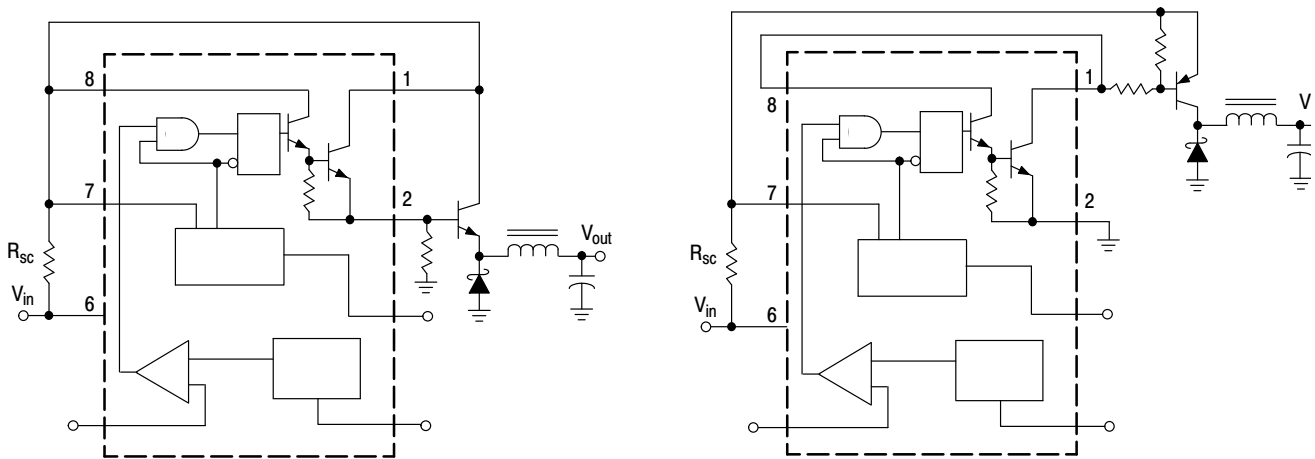
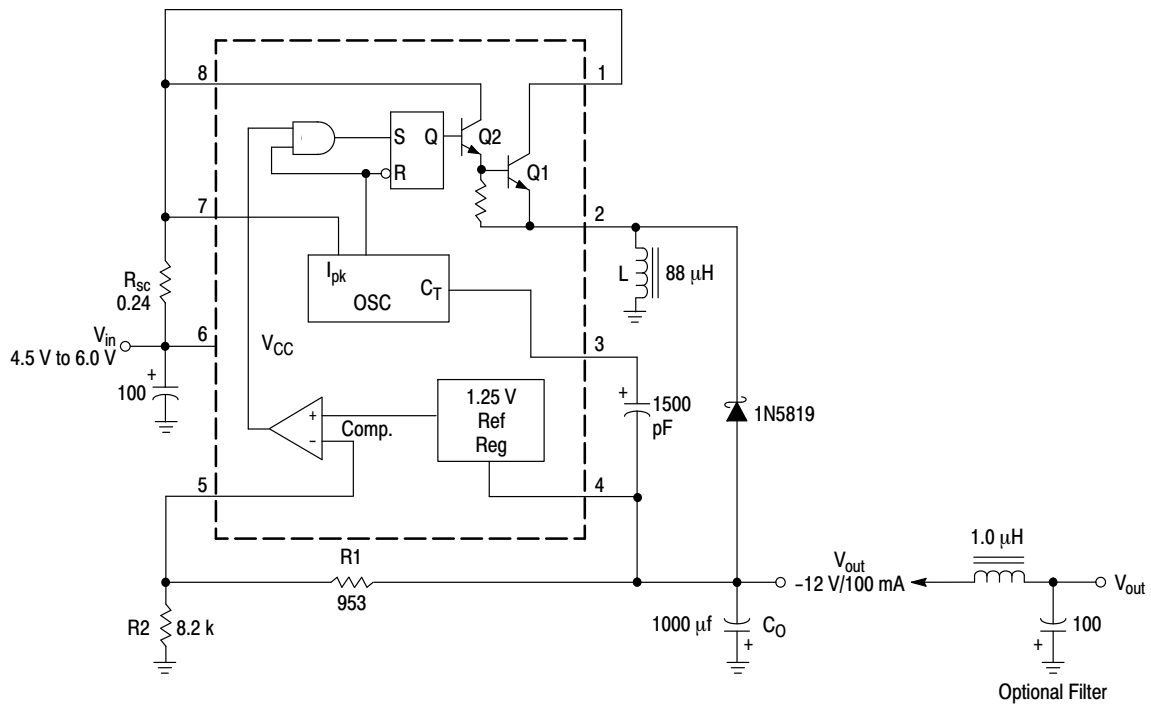

Figure 12. External Current Boost Connections for I_C Peak Greater than 1.5 A

11a. External NPN Switch

11b. External PNP Saturated Switch

MC34063A, MC33063A, SC34063A, SC33063A, NCV33063A



Test	Conditions	Results
Line Regulation	$V_{in} = 4.5 \text{ V to } 6.0 \text{ V}, I_O = 100 \text{ mA}$	$3.0 \text{ mV} = \pm 0.012\%$
Load Regulation	$V_{in} = 5.0 \text{ V}, I_O = 10 \text{ mA to } 100 \text{ mA}$	$0.022 \text{ V} = \pm 0.09\%$
Output Ripple	$V_{in} = 5.0 \text{ V}, I_O = 100 \text{ mA}$	500 mVpp
Short Circuit Current	$V_{in} = 5.0 \text{ V}, R_L = 0.1 \Omega$	910 mA
Efficiency	$V_{in} = 5.0 \text{ V}, I_O = 100 \text{ mA}$	62.2%
Output Ripple With Optional Filter	$V_{in} = 5.0 \text{ V}, I_O = 100 \text{ mA}$	70 mVpp

Figure 13. Voltage Inverting Converter

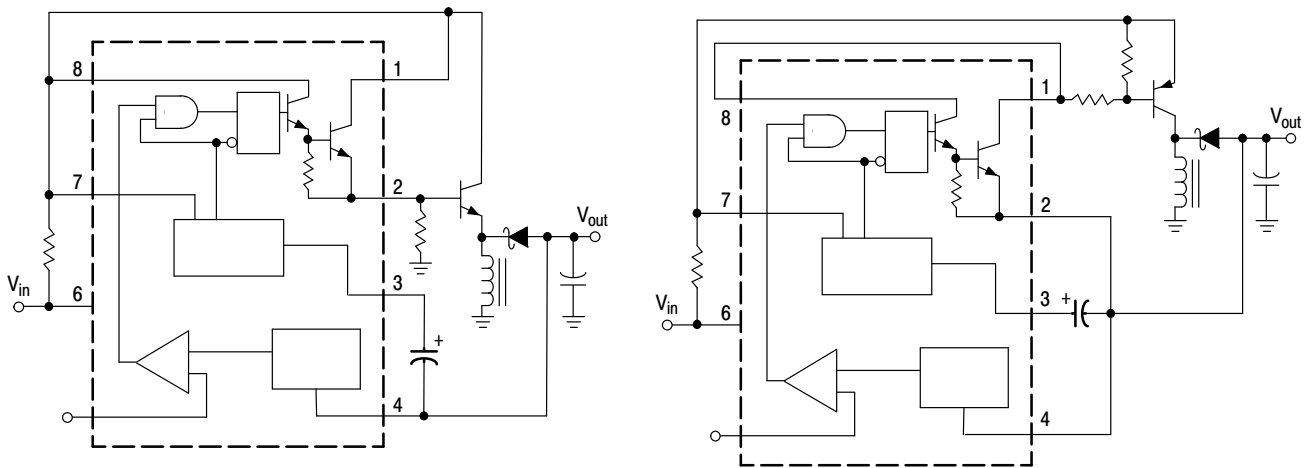
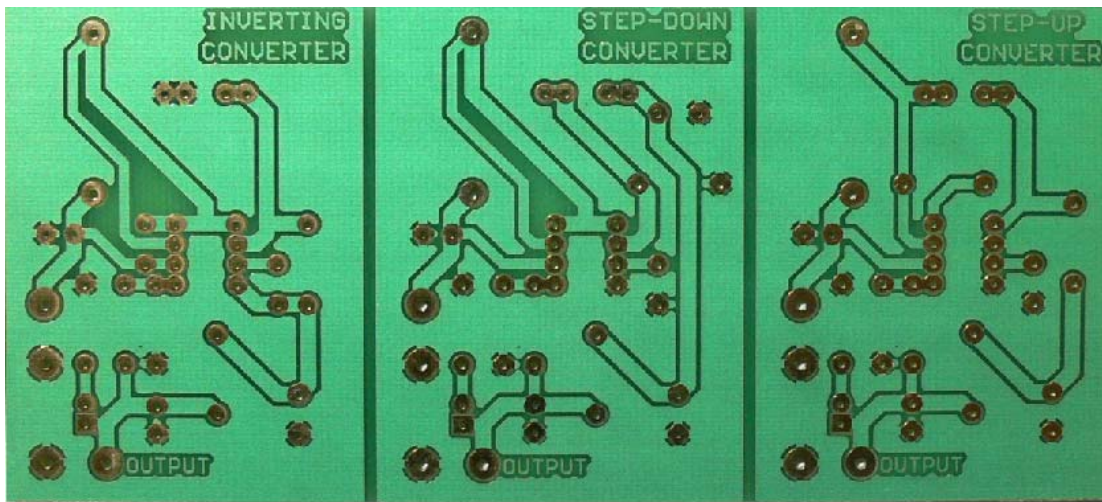

Figure 14. External Current Boost Connections for I_C Peak Greater than 1.5 A

13a. External NPN Switch

13b. External PNP Saturated Switch



(Bottom Side)

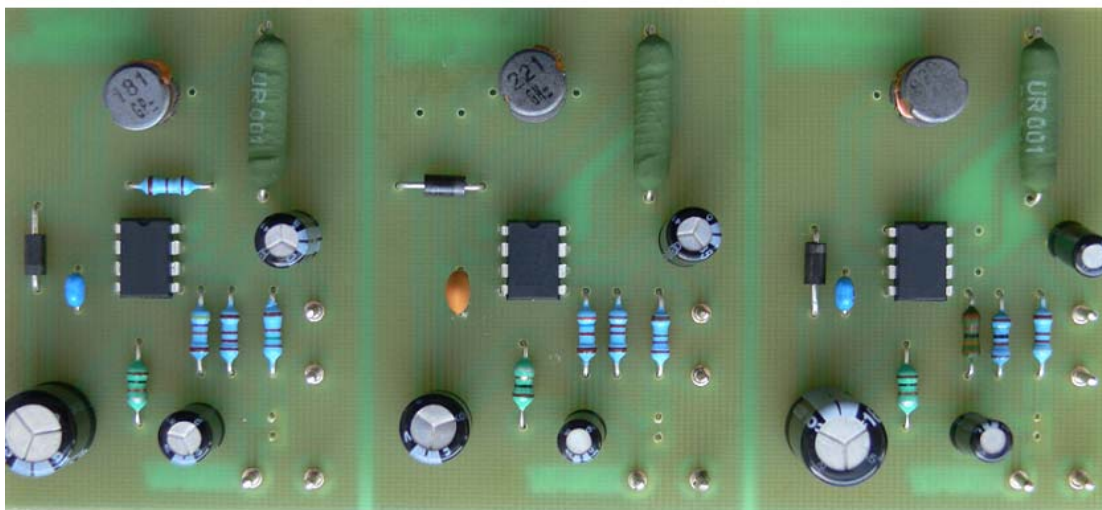

(Top View, Component Side)

Figure 15. Printed Circuit Board and Component Layout
(Circuits of Figures 9, 11, 13)

INDUCTOR DATA

Converter	Inductance (μH)	Turns/Wire
Step-Up	170	38 Turns of #22 AWG
Step-Down	220	48 Turns of #22 AWG
Voltage-Inverting	88	28 Turns of #22 AWG

All inductors are wound on Magnetics Inc. 55117 toroidal core.

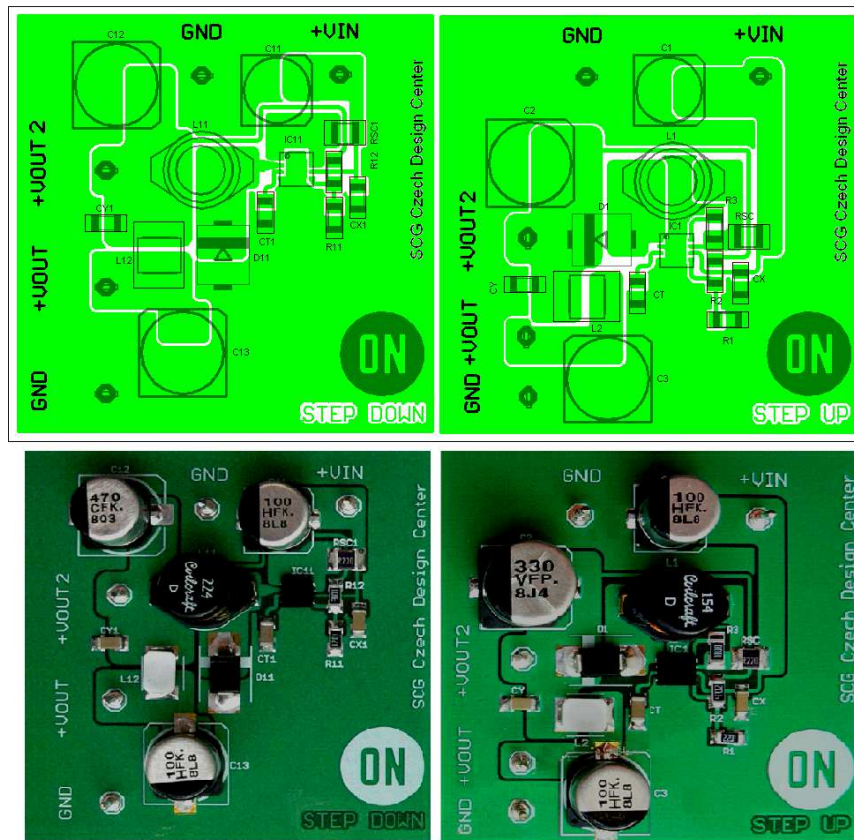

Figure 16. Printed Circuit Board for DFN Device

MC34063A, MC33063A, SC34063A, SC33063A, NCV33063A

Calculation	Step-Up	Step-Down	Voltage-Inverting
t_{on}/t_{off}	$\frac{V_{out} + V_F - V_{in(min)}}{V_{in(min)} - V_{sat}}$	$\frac{V_{out} + V_F}{V_{in(min)} - V_{sat} - V_{out}}$	$\frac{ V_{out} + V_F}{V_{in} - V_{sat}}$
$(t_{on} + t_{off})$	$\frac{1}{f}$	$\frac{1}{f}$	$\frac{1}{f}$
t_{off}	$\frac{t_{on} + t_{off}}{\frac{t_{on}}{t_{off}} + 1}$	$\frac{t_{on} + t_{off}}{\frac{t_{on}}{t_{off}} + 1}$	$\frac{t_{on} + t_{off}}{\frac{t_{on}}{t_{off}} + 1}$
t_{on}	$(t_{on} + t_{off}) - t_{off}$	$(t_{on} + t_{off}) - t_{off}$	$(t_{on} + t_{off}) - t_{off}$
C_T	$4.0 \times 10^{-5} t_{on}$	$4.0 \times 10^{-5} t_{on}$	$4.0 \times 10^{-5} t_{on}$
$I_{pk(switch)}$	$2I_{out(max)} \left(\frac{t_{on}}{t_{off}} + 1 \right)$	$2I_{out(max)}$	$2I_{out(max)} \left(\frac{t_{on}}{t_{off}} + 1 \right)$
R_{sc}	$0.3/I_{pk(switch)}$	$0.3/I_{pk(switch)}$	$0.3/I_{pk(switch)}$
$L_{(min)}$	$\left(\frac{V_{in(min)} - V_{sat}}{I_{pk(switch)}} \right) t_{on(max)}$	$\left(\frac{V_{in(min)} - V_{sat} - V_{out}}{I_{pk(switch)}} \right) t_{on(max)}$	$\left(\frac{V_{in(min)} - V_{sat}}{I_{pk(switch)}} \right) t_{on(max)}$
C_O	$9 \frac{I_{out} t_{on}}{V_{ripple(pp)}}$	$\frac{I_{pk(switch)} (t_{on} + t_{off})}{8V_{ripple(pp)}}$	$9 \frac{I_{out} t_{on}}{V_{ripple(pp)}}$

V_{sat} = Saturation voltage of the output switch.
 V_F = Forward voltage drop of the output rectifier.

The following power supply characteristics must be chosen:

V_{in} – Nominal input voltage.

V_{out} – Desired output voltage, $|V_{out}| = 1.25 \left(1 + \frac{R2}{R1} \right)$

I_{out} – Desired output current.

f_{min} – Minimum desired output switching frequency at the selected values of V_{in} and I_O .

$V_{ripple(pp)}$ – Desired peak-to-peak output ripple voltage. In practice, the calculated capacitor value will need to be increased due to its equivalent series resistance and board layout. The ripple voltage should be kept to a low value since it will directly affect the line and load regulation.

NOTE: For further information refer to Application Note AN920A/D and AN954/D.

Figure 17. Design Formula Table

MC34063A, MC33063A, SC34063A, SC33063A, NCV33063A

ORDERING INFORMATION

Device	Package	Shipping†
MC33063ADG	SOIC-8 (Pb-Free)	98 Units / Rail
MC33063ADR2G	SOIC-8 (Pb-Free)	2500 Units / Tape & Reel
SC33063ADR2G	SOIC-8 (Pb-Free)	2500 Units / Tape & Reel
MC33063AP1G	PDIP-8 (Pb-Free)	50 Units / Rail
MC33063AVDG	SOIC-8 (Pb-Free)	98 Units / Rail
MC33063AVDR2G	SOIC-8 (Pb-Free)	
NCV33063AVDR2G*	SOIC-8 (Pb-Free)	2500 Units / Tape & Reel
MC33063AVPG	PDIP-8 (Pb-Free)	50 Units / Rail
MC34063ADG	SOIC-8 (Pb-Free)	98 Units / Rail
MC34063ADR2G	SOIC-8 (Pb-Free)	2500 Units / Tape & Reel
SC34063ADR2G	SOIC-8 (Pb-Free)	2500 Units / Tape & Reel
MC34063AP1G	PDIP-8 (Pb-Free)	50 Units / Rail
SC34063AP1G	PDIP-8 (Pb-Free)	50 Units / Rail
MC33063MNTXG	DFN8 (Pb-Free)	4000 Units / Tape & Reel

†For information on tape and reel specifications, including part orientation and tape sizes, please refer to our Tape and Reel Packaging Specification Brochure, BRD8011/D.

*NCV33063A: $T_{low} = -40^{\circ}\text{C}$, $T_{high} = +125^{\circ}\text{C}$. Guaranteed by design. NCV prefix is for automotive and other applications requiring site and change control.

PACKAGE DIMENSIONS

SOIC-8 NB
CASE 751-07
ISSUE AK

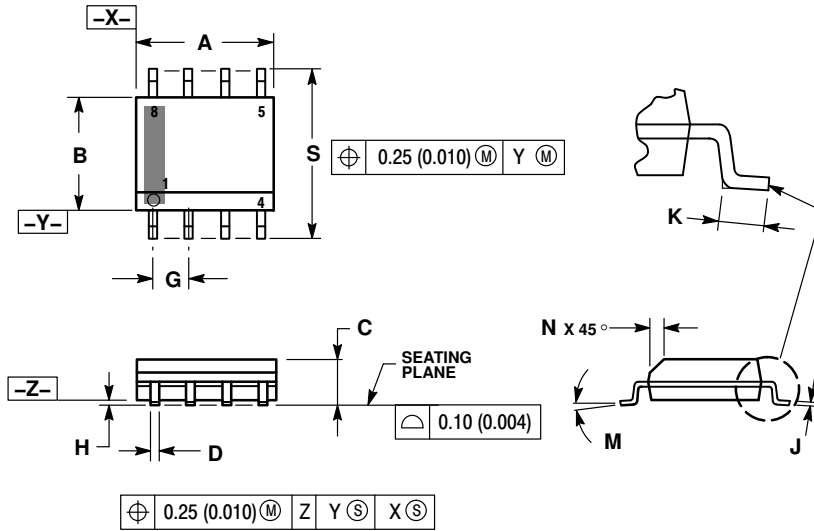

- NOTES:
1. DIMENSIONING AND TOLERANCING PER ANSI Y14.5M, 1982.
 2. CONTROLLING DIMENSION: MILLIMETER.
 3. DIMENSION A AND B DO NOT INCLUDE MOLD PROTRUSION.
 4. MAXIMUM MOLD PROTRUSION 0.15 (0.006) PER SIDE.
 5. DIMENSION D DOES NOT INCLUDE DAMBAR PROTRUSION. ALLOWABLE DAMBAR PROTRUSION SHALL BE 0.127 (0.005) TOTAL IN EXCESS OF THE D DIMENSION AT MAXIMUM MATERIAL CONDITION.
 6. 751-01 THRU 751-06 ARE OBSOLETE. NEW STANDARD IS 751-07.

DIM	MILLIMETERS		INCHES	
	MIN	MAX	MIN	MAX
A	4.80	5.00	0.189	0.197
B	3.80	4.00	0.150	0.157
C	1.35	1.75	0.053	0.069
D	0.33	0.51	0.013	0.020
G	1.27 BSC		0.050 BSC	
H	0.10	0.25	0.004	0.010
J	0.19	0.25	0.007	0.010
K	0.40	1.27	0.016	0.050
M	0°	8°	0°	8°
N	0.25	0.50	0.010	0.020
S	5.80	6.20	0.228	0.244

SOLDERING FOOTPRINT*

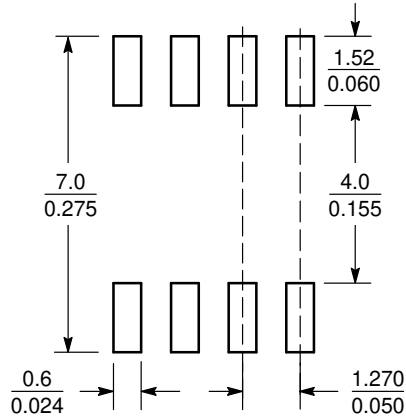

SCALE 6:1 ($\frac{\text{mm}}{\text{inches}}$)

*For additional information on our Pb-Free strategy and soldering details, please download the ON Semiconductor Soldering and Mounting Techniques Reference Manual, SOLDERRM/D.

PACKAGE DIMENSIONS

PDIP-8
P, P1 SUFFIX
CASE 626-05
ISSUE P

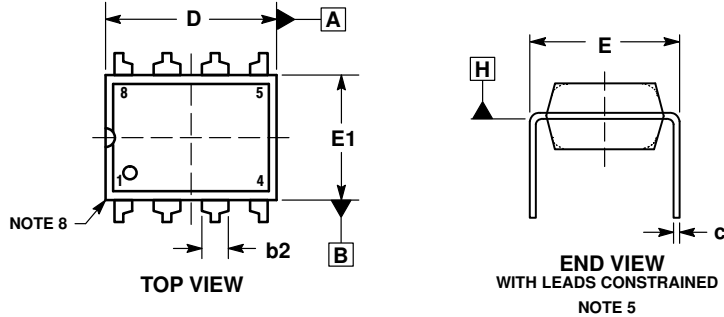

- NOTES:
1. DIMENSIONING AND TOLERANCING PER ASME Y14.5M, 1994.
 2. CONTROLLING DIMENSION: INCHES.
 3. DIMENSIONS A, A1 AND L ARE MEASURED WITH THE PACKAGE SEATED IN JEDEC SEATING PLANE GAUGE GS-3.
 4. DIMENSIONS D, D1 AND E1 DO NOT INCLUDE MOLD FLASH OR PROTRUSIONS. MOLD FLASH OR PROTRUSIONS ARE NOT TO EXCEED 0.10 INCH.
 5. DIMENSION E IS MEASURED AT A POINT 0.015 BELOW DATUM PLANE H WITH THE LEADS CONSTRAINED PERPENDICULAR TO DATUM C.
 6. DIMENSION eB IS MEASURED AT THE LEAD TIPS WITH THE LEADS UNCONSTRAINED.
 7. DATUM PLANE H IS COINCIDENT WITH THE BOTTOM OF THE LEADS, WHERE THE LEADS EXIT THE BODY.
 8. PACKAGE CONTOUR IS OPTIONAL (ROUNDED OR SQUARE CORNERS).

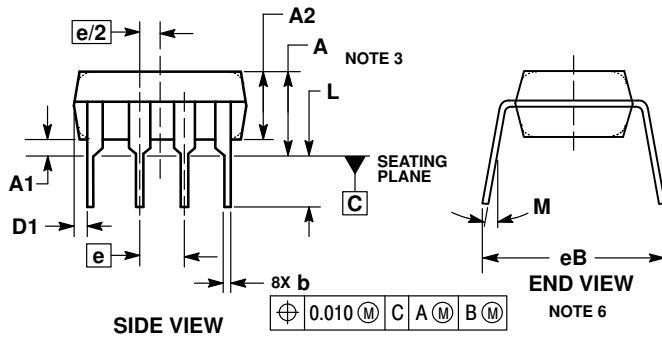

DIM	INCHES		MILLIMETERS	
	MIN	MAX	MIN	MAX
A	---	0.210	---	5.33
A1	0.015	---	0.38	---
A2	0.115	0.195	2.92	4.95
b	0.014	0.022	0.35	0.56
b2	0.060 TYP		1.52 TYP	
C	0.008	0.014	0.20	0.36
D	0.355	0.400	9.02	10.16
D1	0.005	---	0.13	---
E	0.300	0.325	7.62	8.26
E1	0.240	0.280	6.10	7.11
e	0.100 BSC		2.54 BSC	
eB	---	0.430	---	10.92
L	0.115	0.150	2.92	3.81
M	---	10°	---	10°

MC34063A, MC33063A, SC34063A, SC33063A, NCV33063A

PACKAGE DIMENSIONS

DFN8, 4x4 CASE 488AF-01 ISSUE C

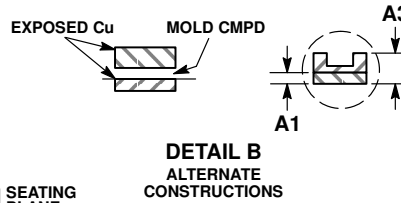
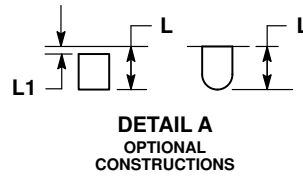
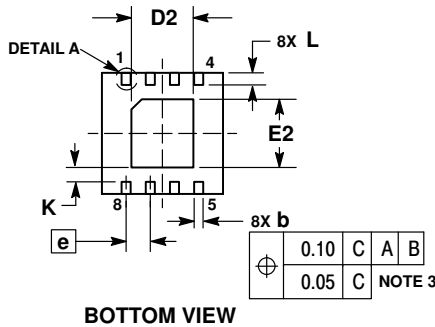
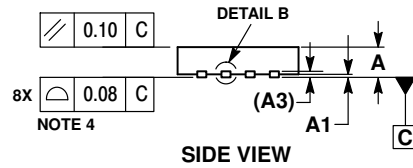
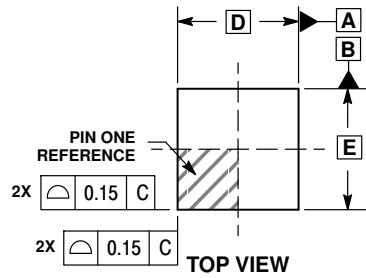

NOTES:

1. DIMENSIONS AND TOLERANCING PER ASME Y14.5M, 1994.
2. CONTROLLING DIMENSION: MILLIMETERS.
3. DIMENSION b APPLIES TO PLATED TERMINAL AND IS MEASURED BETWEEN 0.15 AND 0.30MM FROM TERMINAL TIP.
4. COPLANARITY APPLIES TO THE EXPOSED PAD AS WELL AS THE TERMINALS.
5. DETAILS A AND B SHOW OPTIONAL CONSTRUCTIONS FOR TERMINALS.

DIM	MILLIMETERS	
	MIN	MAX
A	0.80	1.00
A1	0.00	0.05
A3	0.20	REF
b	0.25	0.35
D	4.00	BSC
D2	1.91	2.21
E	4.00	BSC
E2	2.09	2.39
e	0.80	BSC
K	0.20	---
L	0.30	0.50
L1	---	0.15

SOLDERING FOOTPRINT*

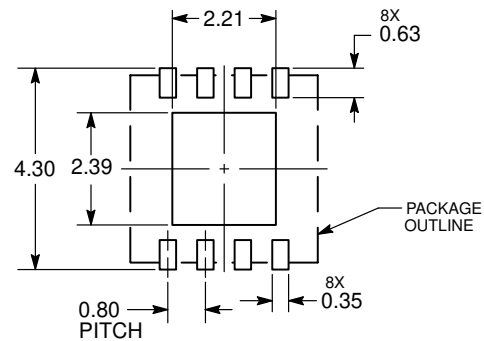

DIMENSIONS: MILLIMETERS

*For additional information on our Pb-Free strategy and soldering details, please download the ON Semiconductor Soldering and Mounting Techniques Reference Manual, SOLDETRM/D.

SENSEFET is a trademark of Semiconductor Components Industries, LLC.

ON Semiconductor and are trademarks of Semiconductor Components Industries, LLC dba ON Semiconductor or its subsidiaries in the United States and/or other countries. ON Semiconductor owns the rights to a number of patents, trademarks, copyrights, trade secrets, and other intellectual property. A listing of ON Semiconductor's product/patent coverage may be accessed at www.onsemi.com/site/pdf/Patent-Marketing.pdf. ON Semiconductor reserves the right to make changes without further notice to any products herein. ON Semiconductor makes no warranty, representation or guarantee regarding the suitability of its products for any particular purpose, nor does ON Semiconductor assume any liability arising out of the application or use of any product or circuit, and specifically disclaims any and all liability, including without limitation special, consequential or incidental damages. Buyer is responsible for its products and applications using ON Semiconductor products, including compliance with all laws, regulations and safety requirements or standards, regardless of any support or applications information provided by ON Semiconductor. "Typical" parameters which may be provided in ON Semiconductor data sheets and/or specifications can and do vary in different applications and actual performance may vary over time. All operating parameters, including "Typicals" must be validated for each customer application by customer's technical experts. ON Semiconductor does not convey any license under its patent rights nor the rights of others. ON Semiconductor products are not designed, intended, or authorized for use as a critical component in life support systems or any FDA Class 3 medical devices or medical devices with a same or similar classification in a foreign jurisdiction or any devices intended for implantation in the human body. Should Buyer purchase or use ON Semiconductor products for any such unintended or unauthorized application, Buyer shall indemnify and hold ON Semiconductor and its officers, employees, subsidiaries, affiliates, and distributors harmless against all claims, costs, damages, and expenses, and reasonable attorney fees arising out of, directly or indirectly, any claim of personal injury or death associated with such unintended or unauthorized use, even if such claim alleges that ON Semiconductor was negligent regarding the design or manufacture of the part. ON Semiconductor is an Equal Opportunity/Affirmative Action Employer. This literature is subject to all applicable copyright laws and is not for resale in any manner.

PUBLICATION ORDERING INFORMATION

LITERATURE FULFILLMENT:
Literature Distribution Center for ON Semiconductor
19521 E. 32nd Pkwy, Aurora, Colorado 80011 USA
Phone: 303-675-2175 or 800-344-3860 Toll Free USA/Canada
Fax: 303-675-2176 or 800-344-3867 Toll Free USA/Canada
Email: orderlit@onsemi.com

N. American Technical Support: 800-282-9855 Toll Free
USA/Canada
Europe, Middle East and Africa Technical Support:
Phone: 421 33 790 2910
Japan Customer Focus Center
Phone: 81-3-5817-1050

ON Semiconductor Website: www.onsemi.com
Order Literature: <http://www.onsemi.com/orderlit>

For additional information, please contact your local Sales Representative