



Chipsmall Limited consists of a professional team with an average of over 10 year of expertise in the distribution of electronic components. Based in Hongkong, we have already established firm and mutual-benefit business relationships with customers from,Europe,America and south Asia,supplying obsolete and hard-to-find components to meet their specific needs.

With the principle of “Quality Parts,Customers Priority,Honest Operation,and Considerate Service”,our business mainly focus on the distribution of electronic components. Line cards we deal with include Microchip,ALPS,ROHM,Xilinx,Pulse,ON,Everlight and Freescale. Main products comprise IC,Modules,Potentiometer,IC Socket,Relay,Connector.Our parts cover such applications as commercial,industrial, and automotives areas.

We are looking forward to setting up business relationship with you and hope to provide you with the best service and solution. Let us make a better world for our industry!



## Contact us

Tel: +86-755-8981 8866 Fax: +86-755-8427 6832

Email & Skype: info@chipsmall.com Web: www.chipsmall.com

Address: A1208, Overseas Decoration Building, #122 Zhenhua RD., Futian, Shenzhen, China



# 300 mA High Efficiency Low Quiescent Current Synchronous Buck Regulator With Z-mode

The 34726 is a high efficiency, low quiescent current ( $I_Q$ ), synchronous buck regulator, implementing Freescale's innovative Z-mode architecture. Freescale's Z-mode architecture greatly improves the ripple performance during light load currents, but still maintains a low quiescent current of 65 $\mu$ A, at no load in "Sleepy" Z-mode.

The 34726 accepts an input voltage in the range of 2.7 to 5.5 V, making it ideally suited for single cell Li-Ion based applications. Factory preset output voltages, ranging from 0.8 to 3.3 V, reduce the number of required auxiliary components. The part is able to provide 300 mA of continuous load current across the input and the output voltage ranges.

The 34726 switches at 2.0 MHz to allow the use of small, surface mount inductors and capacitors to save precious board space.

The 34726 is available in the small, space saving, and low cost, 2x2 UDFN-8 packages. The part is guaranteed for operation over the -25°C to 85°C temperature range.

### Features

- 94% peak efficiency
- 2.0 MHz switching frequency
- 2.7 to 5.5 V input voltage range
- Automatic transition to energy saving light load Z-mode (low ripple)
- Fixed output voltage options from 0.8 to 3.3 V
- 65  $\mu$ A quiescent current during sleepy Z-mode
- 300 mA maximum continuous output current
- Internal 2.0 ms soft start
- Thermal and over-current protection
- 0.1  $\mu$ A quiescent current in shutdown (disabled)
- Ultra thin 2x2 UDFN package
- Pb-free packaging designated by suffix code FC

**34726**

**POWER MANAGEMENT IC**

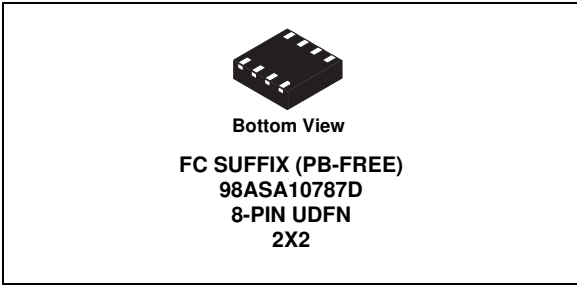

ORDERING INFORMATION		
Device	Temperature Range (T <sub>A</sub> )	Package
Refer to <a href="#">Table 1, Device Variations</a>	-25°C to 85°C	8-UDFN

ARCHIVED INFORMATION Archived

ARCHIVED INFORMATION

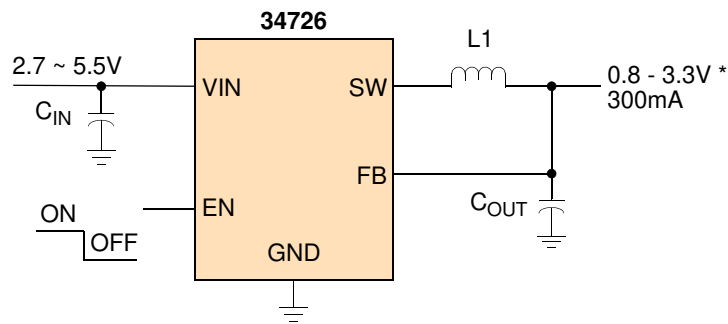

\*Programmable  
See table 1

**Figure 1. 34726 Typical Operating Circuit**

\* This document contains certain information on a new product. Specifications and information herein are subject to change without notice.

## DEVICE VARIATIONS

Table 1. Device Variations

Freescle Part No.	V <sub>IN</sub> Range	Output Voltage <sup>(1)</sup>	Maximum Load Current	Switch Frequency (MHz) <sup>(2)</sup>
MC34726AFC	2.7 - 5.5 V	1.2 V	300 mA	2.0
MC34726BFC	2.7 - 5.5 V	1.8 V	300 mA	2.0
MC34726CFC	3.6 - 5.5 V	3.3 V	300 mA	2.0
MC34726DFC	2.7 - 5.5 V	1.5 V	300 mA	2.0
MC34726EFC	2.7 - 5.5 V	2.5 V	300 mA <sup>(3)</sup>	2.0

Notes

1. Output voltages of: 0.8 V, 0.9 V, 1.0 V, 1.1 V, 1.3 V, 1.4 V, 1.85 V, 2.0 V options available on request. Contact Freescle sales.
2. Factory programmable at 2.0 MHz or 4.0 Mhz. Contact Freescle sales for availability of the 4.0 MHz functionality.
3. The minimum input voltage must be higher than 2.8 V for 300 mA of load current.

## INTERNAL BLOCK DIAGRAM

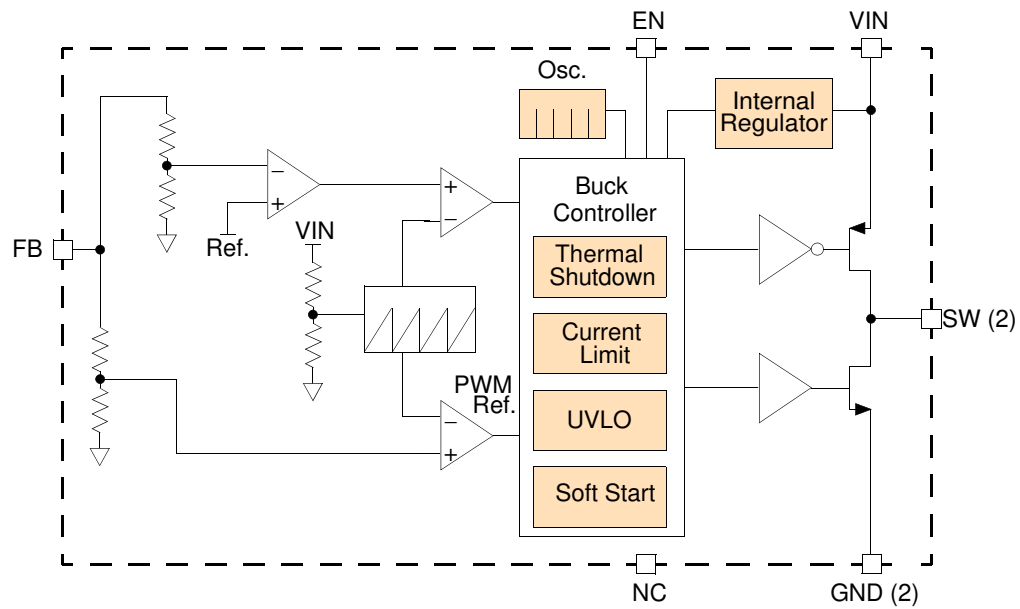

Figure 2. 34726 Simplified Internal Block Diagram





## ELECTRICAL CHARACTERISTICS

### MAXIMUM RATINGS

**Table 3. Maximum Ratings**

All voltages are with respect to ground unless otherwise noted. Exceeding these ratings may cause a malfunction or permanent damage to the device.

Ratings	Symbol	Value	Unit
<b>ELECTRICAL RATINGS</b>			
All pins voltages	$V_{IN}, V_{EN}, V_{FB}, V_{SW}$	-0.3 to 6.0	V
ESD Voltage <sup>(1)</sup>	$V_{ESD}$		V
Human Body Model (HBM)		±2000	
Machine Model (MM)		±200	
<b>THERMAL RATINGS</b>			
Operating Ambient Temperature Range	$T_A$	-25 to +85	°C
Storage Temperature Range	$T_{STG}$	-25 to +150	°C
Maximum Lead Temperature <sup>(2),(3)</sup>	$T_{PPRT}$	Note 3	°C
Junction Temperature	$T_J$		°C
Operating Junction Temperature		125	
Maximum Junction Temperature		+150	
Thermal Resistance <sup>(4)</sup>			°C/W
Junction-to-Case	$R_{\theta JC}$	104	
Junction-to-Ambient	$R_{\theta JA}$	122	
Power Dissipation	$P_D$		W
Continuous (Derate 3.0 mW/°C and over $T_A = 70^\circ\text{C}$ )		0.5	

Notes

- ESD testing is performed in accordance with the Human Body Model (HBM) ( $C_{ZAP} = 100 \text{ pF}$ ,  $R_{ZAP} = 1500 \Omega$ ), and the Machine Model (MM) ( $C_{ZAP} = 200 \text{ pF}$ ,  $R_{ZAP} = 0 \Omega$ ).
- Pin soldering temperature limit is for 10 seconds maximum duration. Not designed for immersion soldering. Exceeding these limits may cause malfunction or permanent damage to the device.
- Freescale's Package Reflow capability meets Pb-free requirements for JEDEC standard J-STD-020C. For Peak Package Reflow Temperature and Moisture Sensitivity Levels (MSL). Go to [www.freescale.com](http://www.freescale.com), search by part number [e.g. remove prefixes/suffixes and enter the core ID to view all orderable parts. (i.e. MC33xxx enter 33xxx)], and review parametrics.
- Device mounted on the Freescale EVB test board per JEDEC DESD51-2.

### STATIC ELECTRICAL CHARACTERISTICS

**Table 4. Static Electrical Characteristics**

Characteristics noted under conditions;  $2.7\text{ V} \leq V_{IN} \leq 5.5\text{ V}$ ,  $0.8\text{ V} \leq V_{OUT} \leq 3.3\text{ V}$ ,  $-25^\circ\text{C} \leq T_A \leq 85^\circ\text{C}$ ,  $C_{IN} = C_{OUT} = 4.7\ \mu\text{F}$ ,  $L1 = 4.7\ \mu\text{H}$  (See Figure 1), unless otherwise noted. The typical specifications are measured at the following conditions;  $T_A = +25^\circ\text{C}$ ,  $V_{IN} = 3.6\text{ V}$ ,  $f_{SW} = 2.0\text{ MHz}$  with the typical operating circuit (See Figure 1), unless otherwise noted.

Characteristic	Symbol	Min	Typ	Max	Unit
Supply Voltage	$V_{IN}$	2.7	-	5.5	V
Output Voltage (Factory preset)	$V_{OUT}$	0.8	-	3.3	V
Output Current	$I_{OUT}$	300	-	-	mA
Total Supply Current <sup>(5)</sup> Regulator disabled	$I_{DIS}$	-	0.1	1.0	$\mu\text{A}$
Quiescent Current (Switching) Sleepy Z-mode and $I_{LOAD} = 0\text{ mA}$	$I_Q$	-	65	85	$\mu\text{A}$
Current Limit Current rising at high side	$I_{PK}$	-	450	-	mA
Output Voltage Accuracy (% of output voltage) Overload and temperature	$\Delta V_{OUT}$	-3%	-	3%	$V_{OUT}$
UVLO Threshold <sup>(6)</sup> $V_{IN}$ : 2.7 -5.5 V $V_{IN}$ rising $V_{IN}$ falling	$V_{UVLO}$	- 2.5	- -	2.7 -	V
Enable Voltage Regulator operating Regulator shutdown	$V_{EN}$	1.6 -	- -	- 0.4	V
High Side Power MOSFET On Resistance $V_{IN} = 3.6\text{ V}$ , $V_{OUT} = 1.8\text{ V}$ , $T_A = 40^\circ\text{C}$ , $I_{LOAD} = 150\text{ mA}$	$R_{DS(ON)H}$	-	250	-	$\text{m}\Omega$
Low Side Power MOSFET On Resistance $V_{IN} = 3.6\text{ V}$ , $V_{OUT} = 1.8\text{ V}$ , $T_A = 40^\circ\text{C}$ , $I_{LOAD} = 150\text{ mA}$	$R_{DS(ON)L}$	-	350	-	$\text{m}\Omega$
Load Regulation $1.0\text{ mA} < I_{LOAD} < 300\text{ mA}$ and $V_{OUT} = 1.8\text{ V}$	$\Delta V_{OUT} / \Delta I_{OUT}$	-	0.5	-	%
Line Regulation $V_{IN} = 2.7$ to $5.5\text{ V}$	$\Delta V_{OUT} / \Delta V_{IN}$	-	0.5	-	%
Start-up Overshoot (% of output voltage) $I_{LOAD} = 0\text{ mA}$ , $V_{OUT} = 1.8\text{ V}$ and $C_{OUT} = 4.7\ \mu\text{F}$	$V_{STO}$	-	3%	-	$V_{OUT}$
Thermal Shutdown Threshold (Junction Temperature)	$T_{STDN}$	-	140	-	$^\circ\text{C}$
Thermal Shutdown Hysteresis (Junction Temperature)	$T_{HYSTR}$	-	10	-	$^\circ\text{C}$

Notes

- Maximum  $I_{DIS}$  measured at  $V_{IN} = 3.6\text{ V}$  and  $T_A = 25^\circ\text{C}$ .
- For a product with a  $V_{OUT}$  of  $3.3\text{ V}$  and a  $V_{IN}$  minimum less than  $3.6\text{ V}$ , the  $V_{OUT}$  value will track (drop below  $3.3\text{ V}$ )  $V_{IN}$  down to a value of  $2.5\text{ V}$ , where the UVLO shutdown mechanism will activate.

**DYNAMIC ELECTRICAL CHARACTERISTICS****Table 5. Dynamic Electrical Characteristics**

Characteristics noted under conditions;  $2.7\text{ V} \leq V_{\text{IN}} \leq 5.5\text{ V}$ ,  $0.8\text{ V} \leq V_{\text{OUT}} \leq 3.3\text{ V}$ ,  $-20^{\circ}\text{C} \leq T_{\text{A}} \leq 85^{\circ}\text{C}$ ,  $C_{\text{IN}} = C_{\text{OUT}} = 4.7\text{ }\mu\text{F}$ ,  $L_1 = 4.7\text{ }\mu\text{H}$  (See [Figure 1](#)), unless otherwise noted. The typical specifications are measured at the following conditions;  $T_{\text{A}} = +25^{\circ}\text{C}$ ,  $V_{\text{IN}} = 3.6\text{ V}$ ,  $f_{\text{SW}} = 2.0\text{ MHz}$  with the typical operating circuit (See [Figure 1](#)), unless otherwise noted.

Characteristic	Symbol	Min	Typ	Max	Unit
Switching Frequency <sup>(7)</sup>	$f_{\text{SW}}$	1.8	2.0	2.2	MHz
Maximum Duty Cycle <sup>(8)</sup> Measured from SW pin	$D_{\text{MAX}}$	95	-	100	%
Internal Soft-start Timer $V_{\text{OUT}}$ Rise Time	$t_{\text{S}}$	-	2.0	-	ms

## Notes

- $f_{\text{SW}}$  can be factory programmed to  $\pm 20\%$  of nominal 2.0 MHz.
- The maximum duty limits the range of output voltages achievable for a given input voltage.



ELECTRICAL PERFORMANCE CURVES

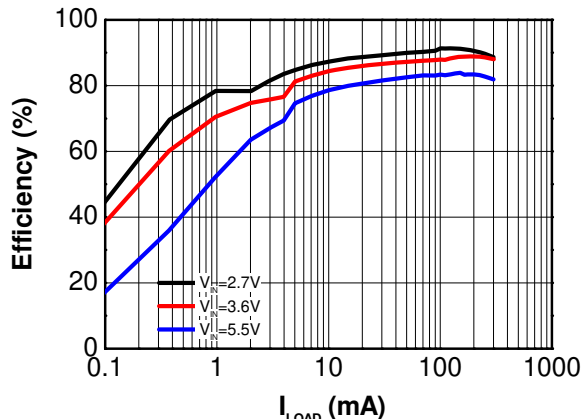

Figure 4. Efficiency vs. Load Current  
 $V_{IN} = 3.6\text{ V}$ ,  $V_{OUT} = 1.8\text{ V}$ ,  $T_A = 25^\circ\text{C}$

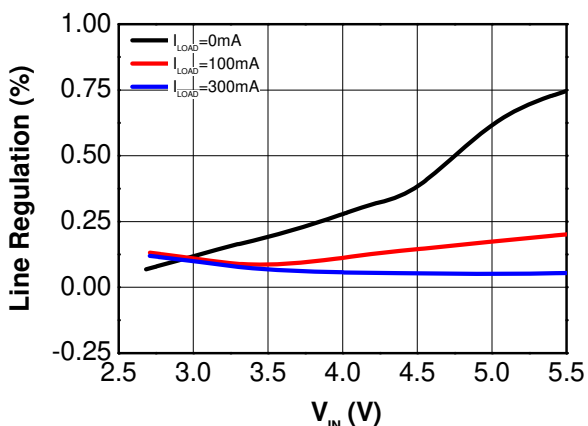

Figure 5. Line Regulation  
 $V_{IN}$  is  $2.7\text{ V}$  to  $5.5\text{ V}$  and  $V_{OUT}$  is  $1.8\text{ V}$ ,  $T_A = 25^\circ\text{C}$

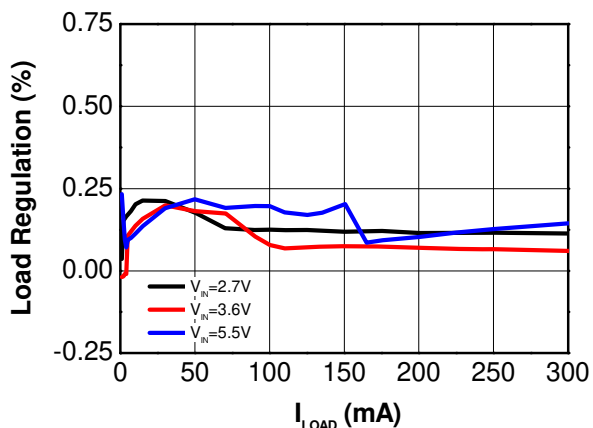

Figure 6. Load Regulation  
 $1.0\text{ mA} < I_{LOAD} < 300\text{ mA}$ ,  $V_{OUT} = 1.8\text{ V}$

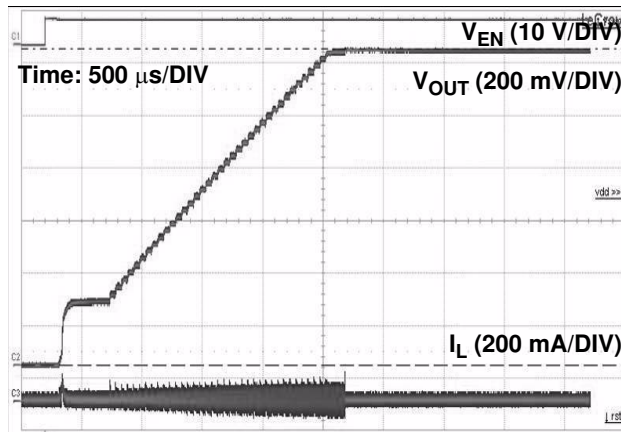

Figure 7. Start-up Response  
 $I_{LOAD} = 0\text{ mA}$ ,  $V_{OUT} = 1.2\text{ V}$

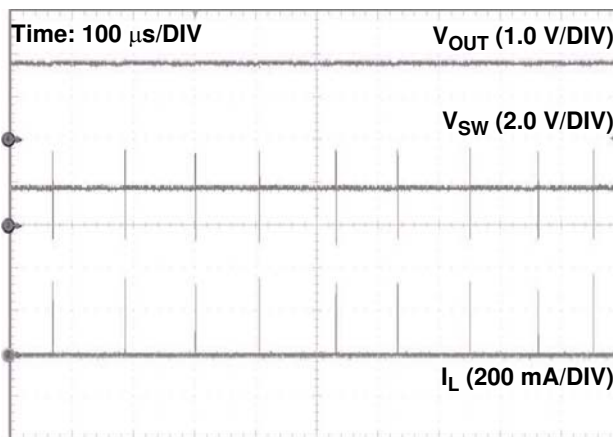

Figure 8. Sleepy Z-Mode™ Switching Waveforms  
 $V_{IN} = 3.6\text{ V}$ ,  $V_{OUT} = 1.8\text{ V}$  and  $I_{LOAD} = 1.0\text{ mA}$

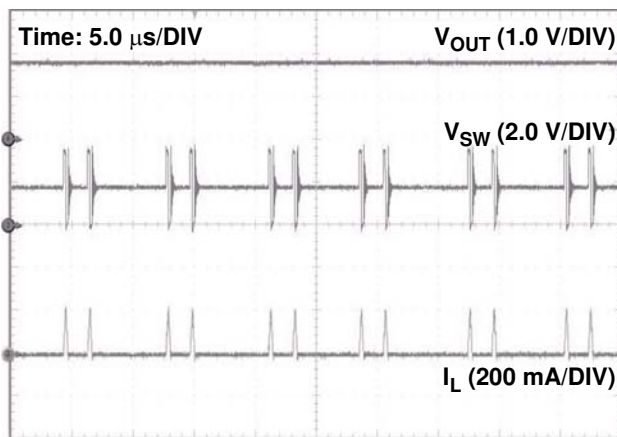
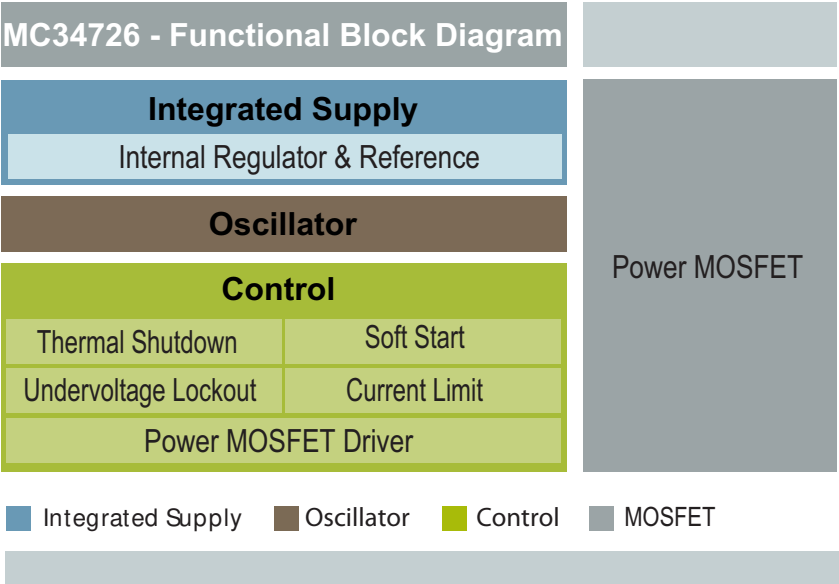

Figure 9. Z-Mode™ Switching Waveforms  
 $V_{IN} = 3.6\text{ V}$ ,  $V_{OUT} = 1.8\text{ V}$  and  $I_{LOAD} = 10\text{ mA}$





**FUNCTIONAL INTERNAL BLOCK DESCRIPTION**



**Figure 14. 34726 Functional Internal Block Diagram**

**INTEGRATED SUPPLY**

**INTERNAL REGULATOR AND REFERENCE**

The internal regulator and reference block steps down the high input voltage to lower voltage to power all the internal blocks, and provides the reference voltage for the other internal blocks.

**OSCILLATOR**

The oscillator block provides 2.0 MHz clock signal to the controller.

**CONTROLLER**

**THERMAL SHUTDOWN**

The thermal shutdown block monitors the die temperature. Once the die temperature reaches its threshold, this block turns off the device to prevent the further die temperature rise.

**SOFT-START**

The soft-start block controls the output voltage ramp after the device is enabled, to limit the in-rush current. The start-up time is internally set to approximately 2.0 ms, and is

independent of input voltage, output voltage, or load current. The soft-start sequence also occurs upon recovery from any fault condition.

**UVLO**

The UVLO block monitors the input voltage. Once the input voltage is lower than the falling threshold voltage, this block turns off the device, to avoid unpredictable circuit behavior.

**CURRENT LIMIT**

The current limit block monitors the inductor current. When the peak inductor current reaches its current limit, this block turns off the high side MOSFET, to prevent the device and external components from damage.

**POWER-MOSFET DRIVER**

The power-MOSFET-driver block controls the phase of the driver signals and enhances the drive capability of these.

**POWER-MOSFET**

The power-MOSFET block contains two power MOSFETs. One is a PMOS that passes the current from the input to the output, and the other one is an NMOS that provides the inductor current loop when PMOS is turned off.

Archived Archived Archived Archived Archived Archived Archived Archived Archived Archived



Archived Archived Archived Archived Archived Archived Archived Archived Archived Archived Archived Archived

**OVER-TEMPERATURE PROTECTION**

To limit its operating temperature, the 34726 shuts down if the junction temperature of the switching MOSFET surpasses 140°C. If the junction temperature subsequently drops to 130°C, the 34726 restarts.

**SOFT-START OPERATION**

To limit the in-rush current, an internal timer controls the output voltage ramp after the part is enabled. The start-up time is internally set to approximately 2.0 ms and is independent of input voltage, output voltage, or load current.

The soft-start sequence also occurs upon recovery from any fault condition.

**UNDER-VOLTAGE LOCK-OUT**

The UVLO threshold is set to 2.7 V for rising  $V_{IN}$ , and to 2.5 V for falling  $V_{IN}$ . For a  $V_{OUT}$  of 3.3 V or 2.5 V, the  $V_{OUT}$  value will track  $V_{IN}$  below 3.6 V or 2.8 V until the 2.5 V falling  $V_{IN}$  threshold is reached.

If the UVLO falling threshold is met, the part shuts down and will power-up again with soft-start, when the UVLO rising threshold is surpassed.



## TYPICAL APPLICATIONS

### APPLICATION INFORMATION

#### INPUT CAPACITOR

The input capacitor is used to minimize the input voltage transient that may cause instability when the load transient current is high. Typically a 4.7  $\mu\text{F}$  X5R ceramic capacitor is sufficient for most applications.

#### OUTPUT CAPACITOR

For stable operation and low output voltage ripple, an X5R ceramic capacitor of 4.7  $\mu\text{F}$  minimum value is needed.

Depending on the load transient current, a larger capacitance may be required.

#### INDUCTOR SELECTION

A 4.7  $\mu\text{H}$  low DC resistance inductor is typically used for the 34726 to guarantee the system stable operation.

## TYPICAL APPLICATIONS

### 1.2 V OUTPUT DC/DC CONVERTOR

[Figure 16](#) shows a typical application using 34726A.  $C_{\text{IN}}$  and  $C_{\text{OUT}}$  are typically 4.7  $\mu\text{F}$ /X5R ceramic capacitors. L1 is typically a 4.7  $\mu\text{H}$  low DC resistance inductor. The FB

connects to the output directly for monitoring the output voltage. Normally, the EN pin connects to the input supply directly to enable the regulator.

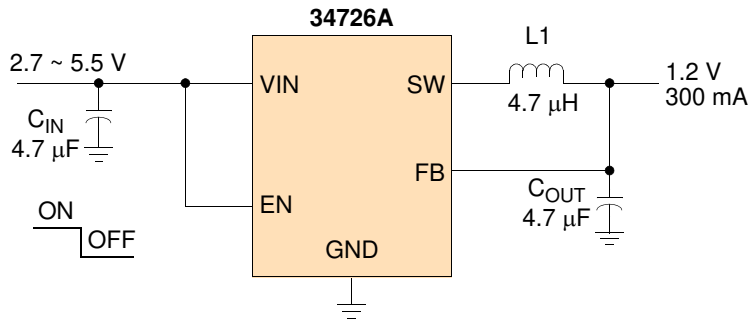

Figure 16. 1.2 V/300 mA DC/DC Converter







## REVISION HISTORY

REVISION	DATE	DESCRIPTION OF CHANGES
1.0	5/2008	<ul style="list-style-type: none"><li>Initial Release</li></ul>
2.0	9/2009	<ul style="list-style-type: none"><li>Minor adjustments to the Ordering information and <a href="#">Device Variations</a></li><li>Updated to match the current Freescale format and style.</li></ul>
	1/2014	<ul style="list-style-type: none"><li>Added archive information</li></ul>

Archived Archived Archived Archived Archived Archived Archived Archived Archived Archived

