



Chipsmall Limited consists of a professional team with an average of over 10 year of expertise in the distribution of electronic components. Based in Hongkong, we have already established firm and mutual-benefit business relationships with customers from,Europe,America and south Asia,supplying obsolete and hard-to-find components to meet their specific needs.

With the principle of “Quality Parts,Customers Priority,Honest Operation,and Considerate Service”,our business mainly focus on the distribution of electronic components. Line cards we deal with include Microchip,ALPS,ROHM,Xilinx,Pulse,ON,Everlight and Freescale. Main products comprise IC,Modules,Potentiometer,IC Socket,Relay,Connector.Our parts cover such applications as commercial,industrial, and automotives areas.

We are looking forward to setting up business relationship with you and hope to provide you with the best service and solution. Let us make a better world for our industry!



Contact us

Tel: +86-755-8981 8866 Fax: +86-755-8427 6832

Email & Skype: info@chipsmall.com Web: www.chipsmall.com

Address: A1208, Overseas Decoration Building, #122 Zhenhua RD., Futian, Shenzhen, China



MC3479

Stepper Motor Driver

The MC3479 is designed to drive a two-phase stepper motor in the bipolar mode. The circuit consists of four input sections, a logic decoding/sequencing section, two driver-stages for the motor coils, and an output to indicate the Phase A drive state.

Features

- Single Supply Operation: 7.2 to 16.5 V
- 350 mA/Coil Drive Capability
- Clamp Diodes Provided for Back-EMF Suppression
- Selectable CW/CCW and Full/Half Step Operation
- Selectable High/Low Output Impedance (Half Step Mode)
- TTL/CMOS Compatible Inputs
- Input Hysteresis: 400 mV Minimum
- Phase Logic Can Be Initialized to Phase A
- Phase A Output Drive State Indication (Open-Collector)
- Pb-Free Package is Available*

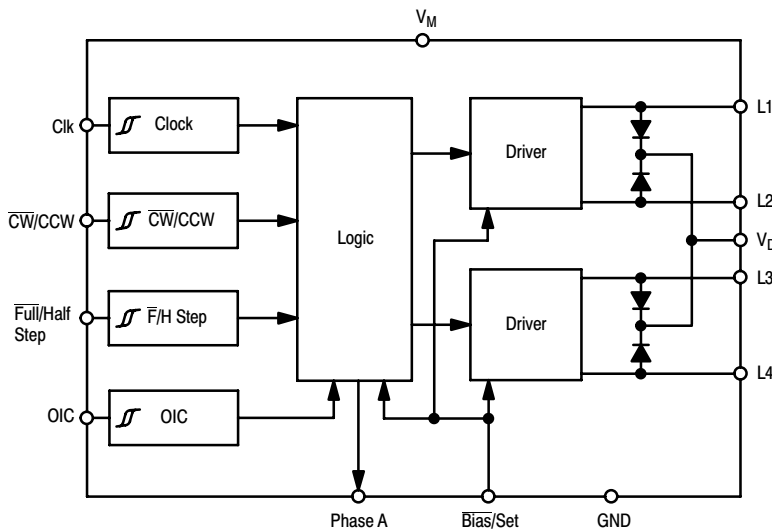

Figure 1. Representative Block Diagram

ORDERING INFORMATION

Device	Operating Temperature Range	Package	Shipping
MC3479P	$T_A = 0^\circ \text{ to } +70^\circ \text{C}$	PDIP-16	25 Units / Rail
MC3479PG		PDIP-16 (Pb-Free)	

*For additional information on our Pb-Free strategy and soldering details, please download the ON Semiconductor Soldering and Mounting Techniques Reference Manual, SOLDERRM/D.



ON Semiconductor®

<http://onsemi.com>

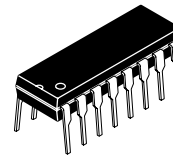

PDIP-16
P SUFFIX
CASE 648C

MARKING DIAGRAM

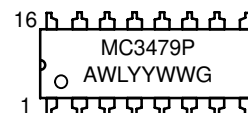

A = Assembly Location
WL = Wafer Lot
YY = Year
WW = Work Week
G = Pb-Free Package

PIN CONNECTIONS

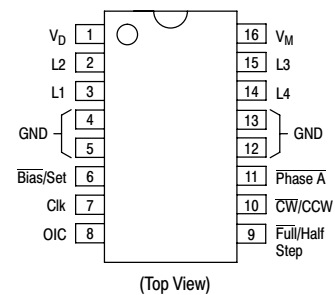

INPUT TRUTH TABLE

	Input Low	Input High
CW/CCW	CW	CCW
Full/Half Step	Full Step	Half Step
OIC	Hi Z	Low Z
Clk	Positive Edge Triggered	

MC3479

MAXIMUM RATINGS

Rating	Symbol	Value	Unit
Supply Voltage	V_M	+ 18	Vdc
Clamp Diode Cathode Voltage (Pin 1)	V_D	$V_M + 5.0$	Vdc
Driver Output Voltage	V_{OD}	$V_M + 6.0$	Vdc
Drive Output Current/Coil	I_{OD}	± 500	mA
Input Voltage (Logic Controls)	V_{in}	- 0.5 to + 7.0	Vdc
Bias/Set Current	I_{BS}	- 10	mA
Phase A Output Voltage	V_{OA}	+ 18	Vdc
Phase A Sink Current	I_{OA}	20	mA
Junction Temperature	T_J	+ 150	°C
Storage Temperature Range	T_{stg}	- 65 to + 150	°C

Stresses exceeding Maximum Ratings may damage the device. Maximum Ratings are stress ratings only. Functional operation above the Recommended Operating Conditions is not implied. Extended exposure to stresses above the Recommended Operating Conditions may affect device reliability.

RECOMMENDED OPERATING CONDITIONS

Characteristic	Symbol	Min	Max	Unit
Supply Voltage	V_M	+ 7.2	+ 16.5	Vdc
Clamp Diode Cathode Voltage	V_D	V_M	$V_M + 4.5$	Vdc
Driver Output Current (Per Coil) (Note 1)	I_{OD}	-	350	mA
Input Voltage (Logic Controls)	V_{in}	0	+ 5.5	Vdc
Bias/Set Current (Outputs Active)	I_{BS}	-300	- 75	μ A
Phase A Output Voltage	V_{OA}	-	V_M	Vdc
Phase A Sink Current	I_{OA}	0	8.0	mA
Operating Ambient Temperature	T_A	0	+ 70	°C

1. See section on Power Dissipation in Application Information.

DC ELECTRICAL CHARACTERISTICS (Specifications apply over the recommended supply voltage and temperature range, (Notes 2, 3) unless otherwise noted.)

Characteristic	Pins	Symbol	Min	Typ	Max	Unit
----------------	------	--------	-----	-----	-----	------

INPUT LOGIC LEVELS

Threshold Voltage (Low-to-High)	7, 8, 9, 10	V_{TLH}	-	-	2.0	Vdc
Threshold Voltage (High-to-Low)		V_{THL}	0.8	-	-	Vdc
Hysteresis		V_{HYS}	0.4	-	-	Vdc
Current: ($V_I = 0.4$ V) ($V_I = 5.5$ V) ($V_I = 2.7$ V)		I_{IL}	-100 - -	- - -	- +100 +20	μ A

DRIVER OUTPUT LEVELS

Output High Voltage ($I_{BS} = -300$ μ A)	$I_{OD} = -350$ mA $I_{OD} = -0.1$ mA	2, 3, 14, 15	V_{OHD}	$V_M - 2.0$ $V_M - 1.2$	- -	- -	Vdc
Output Low Voltage ($I_{BS} = -300$ μ A, $I_{OD} = 350$ mA)			V_{OLD}	-	-	0.8	Vdc
Differential Mode Output Voltage Difference (Note 4) ($I_{BS} = -300$ μ A, $I_{OD} = 350$ mA)	14, 15		DV_{OD} CV_{OD}	- -	- -	0.15 0.15	Vdc
Output Leakage, Hi Z State ($0 \leq V_{OD} \leq V_M$, $I_{BS} = -5.0$ μ A) ($0 \leq V_{OD} \leq V_M$, $I_{BS} = -300$ μ A, F/H = 2.0 V, OIC = 0.8 V)	14, 15		I_{OZ1} I_{OZ2}	-100 -100	- -	+100 +100	μ A

CLAMP DIODES

Forward Voltage ($I_D = 350$ mA)	1, 2, 3, 14, 15	V_{DF}	-	2.5	3.0	Vdc
Leakage Current (Per Diode) (Pin 1 = 21 V; Outputs = 0 V; $I_{BS} = 0$ μ A)		I_{DR}	-	-	100	μ A

MC3479

DC ELECTRICAL CHARACTERISTICS (Specifications apply over the recommended supply voltage and temperature range, (Notes 2, 3) unless otherwise noted.)

Characteristic	Pins	Symbol	Min	Typ	Max	Unit
----------------	------	--------	-----	-----	-----	------

PHASE A OUTPUT

Output Low Voltage ($I_{OA} = 8.0 \text{ mA}$)	11	V_{OLA}	–	–	0.4	Vdc
Off State Leakage Current ($V_{OHA} = 16.5 \text{ V}$)		I_{OHA}	–	–	100	μA

POWER SUPPLY

Power Supply Current ($I_{OD} = 0 \mu\text{A}$, $I_{BS} = -300 \mu\text{A}$) (L1 = V_{OHD} , L2 = V_{OLD} , L3 = V_{OHD} , L4 = V_{OLD}) (L1 = V_{OHD} , L2 = V_{OLD} , L3 = Hi Z, L4 = Hi Z) (L1 = V_{OHD} , L2 = V_{OLD} , L3 = V_{OHD} , L4 = V_{OHD})	16	I_{MW} I_{MZ} I_{MN}	– – –	– – –	70 40 75	mA
--	----	----------------------------------	-------------	-------------	----------------	----

BIAS/SET CURRENT

To Set Phase A	6	I_{BS}	– 5.0	–	–	μA
----------------	---	----------	-------	---	---	---------------

- Algebraic convention rather than absolute values is used to designate limit values.
- Current into a pin is designated as positive. Current out of a pin is designated as negative.
- $DV_{OD} = |V_{OD1,2} - V_{OD3,4}|$ where: $V_{OD1,2} = (V_{OHD1} - V_{OLD2})$ or $(V_{OHD2} - V_{OLD1})$, and $V_{OD3,4} = (V_{OHD3} - V_{OLD4})$ or $(V_{OHD4} - V_{OLD3})$.

PACKAGE THERMAL CHARACTERISTICS

Characteristic	Symbol	Min	Typ	Max	Unit
Thermal Resistance, Junction-to-Ambient (No Heatsink)	$R_{\theta JA}$	–	45	–	$^{\circ}\text{C/W}$

AC SWITCHING CHARACTERISTICS

 ($T_A = +25^{\circ}\text{C}$, $V_M = 12 \text{ V}$) (See Figures 2, 3, 4) (Notes 5, 6)

Characteristic	Pins	Symbol	Min	Typ	Max	Unit
Clock Frequency	7	f_{CK}	0	–	50	kHz
Clock Pulse Width (High)	7	PW_{CKH}	10	–	–	μs
Clock Pulse Width (Low)	7	PW_{CKL}	10	–	–	μs
Bias/Set Pulse Width	6	PW_{BS}	10	–	–	μs
Setup Time (\overline{CW}/CCW and \overline{F}/HS)	10–7 9–7	t_{su}	5.0	–	–	μs
Hold Time (\overline{CW}/CCW and \overline{F}/HS)	10–7 9–7	t_h	10	–	–	μs
Propagation Delay (Clk-to-Driver Output)		t_{PCD}	–	8.0	–	μs
Propagation Delay (Bias/Set-to-Driver Output)		t_{PBSD}	–	1.0	–	μs
Propagation Delay (Clk-to-Phase A Low)	7–11	t_{PHLA}	–	12	–	μs
Propagation Delay (Clk-to-Phase A High)	7–11	t_{PLHA}	–	5.0	–	μs

- Algebraic convention rather than absolute values is used to designate limit values.
- Current into a pin is designated as positive. Current out of a pin is designated as negative.

MC3479

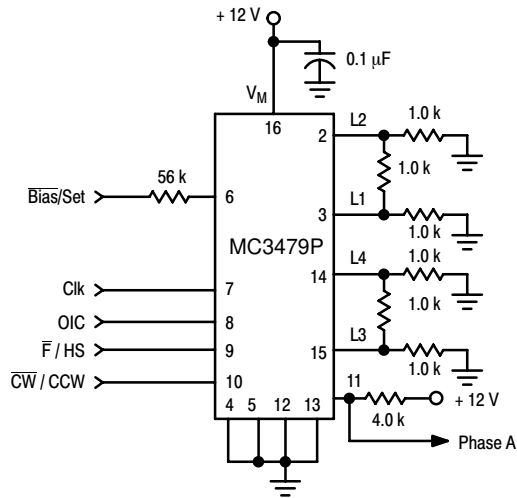
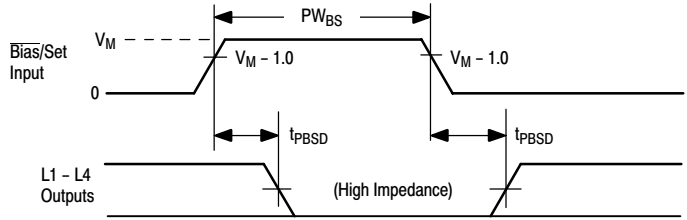

Figure 2. AC Test Circuit



Note: t_r , t_f (10% to 90%) for input signals are ≤ 25 ns.

Figure 3. $\overline{\text{Bias/Set}}$ Timing (Refer to Figure 2)

PIN FUNCTION DESCRIPTION

Pin #	Function	Symbol	Description
16	Power Supply	V_M	Power supply pin for both the logic circuit and the motor coil current. Voltage range is + 7.2 to + 16.5 V.
4, 5, 12, 13	Ground	GND	Ground pins for the logic circuit and the motor coil current. The physical configuration of the pins aids in dissipating heat from within the IC package.
1	Clamp Diode Voltage	V_D	This pin is used to protect the outputs where large voltage spikes may occur as the motor coils are switched. Typically a diode is connected between this pin and Pin 16. See Figure 12.
2, 3, 14, 15	Driver Outputs	L1, L2 L3, L4	High current outputs for the motor coils. L1 and L2 are connected to one coil, and L3 and L4 to the other coil.
6	$\overline{\text{Bias/Set}}$	$\overline{\text{B/S}}$	This pin is typically 0.7 volts below V_M . The current out of this pin (through a resistor to ground) determines the maximum output sink current. If the pin is opened ($I_{BS} < 5.0 \mu\text{A}$) the outputs assume a high impedance condition, while the internal logic presets to a Phase A condition.
7	Clock	Clk	The positive edge of the clock input switches the outputs to the next position. This input has no effect if Pin 6 is open.
9	$\overline{\text{Full/Half Step}}$	$\overline{\text{F/HS}}$	When low (Logic "0"), each clock input pulse will cause the motor to rotate one full step. When high, each clock pulse will cause the motor to rotate one-half step. See Figure 7 for sequence.
10	$\overline{\text{Clockwise/ Counterclockwise}}$	$\overline{\text{CW/CCW}}$	This input allows reversing the rotation of the motor. See Figure 7 for sequence.
8	Output Impedance Control	OIC	This input is relevant only in the half step mode (Pin 9 > 2.0 V). When low (Logic "0"), the two driver outputs of the non-energized coil will be in a high impedance condition. When high the same driver outputs will be at a low impedance referenced to V_M . See Figure 7.
11	Phase A	Ph A	This open-collector output indicates (when low) that the driver outputs are in the Phase A condition ($L1 = L3 = V_{OHD}$, $L2 = L4 = V_{OLD}$).

APPLICATION INFORMATION

General

The MC3479 integrated circuit is designed to drive a stepper positioning motor in applications such as disk drives and robotics. The outputs can provide up to 350 mA to each of two coils of a two-phase motor. The outputs change state with each low-to-high transition of the clock input, with the new output state depending on the previous state, as well as the input conditions at the logic controls.

Outputs

The outputs (L1–L4) are high current outputs (see Figure 5), which when connected to a two-phase motor, provide two full-bridge configurations (L3 and L4 are not shown in Figure 5). The polarities applied to the motor coils depend on which transistor (Q_H or Q_L) of each output is on, which in turn depends on the inputs and the decoding circuitry.

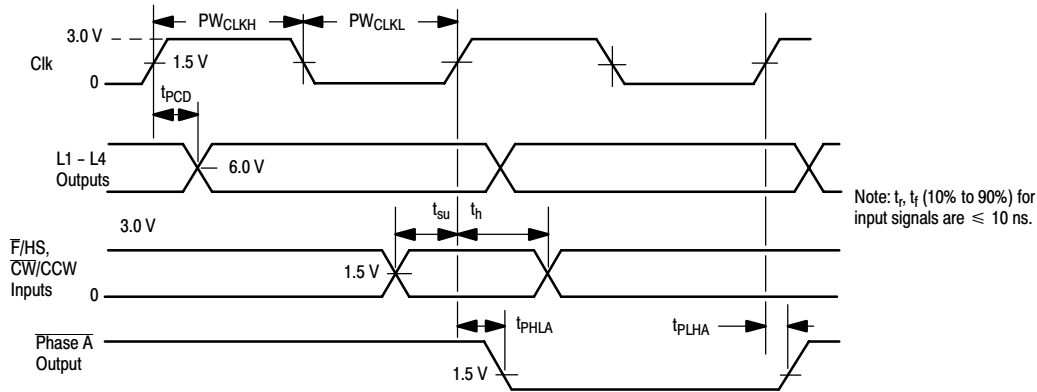

Figure 4. Clock Timing (Refer to Figure 2)

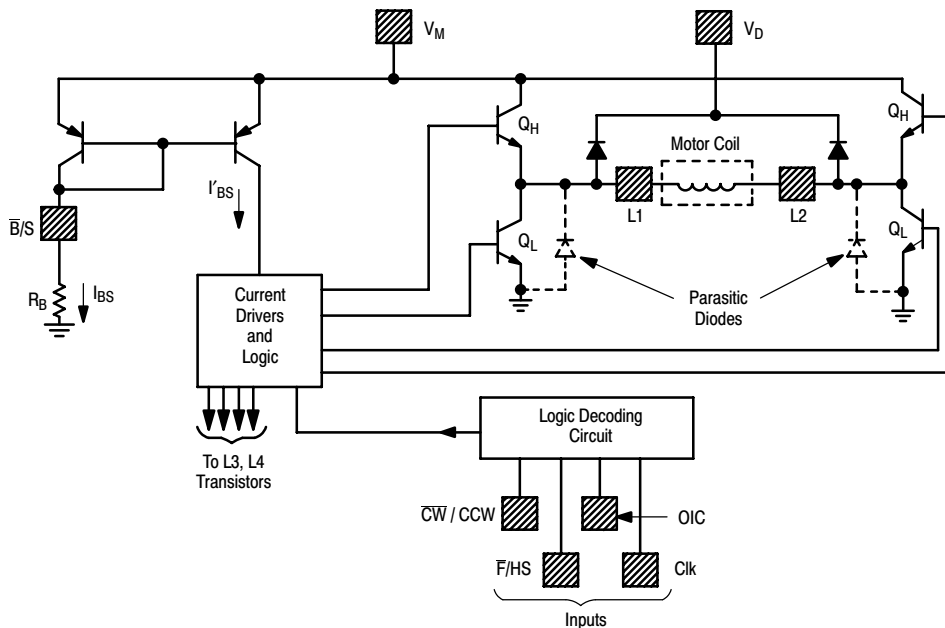

Figure 5. Output Stages

The maximum sink current available at the outputs is a function of the resistor connected between Pin 6 and ground (see section on Bias/Set operation). Whenever the outputs

are to be in a high impedance state, both transistors (Q_H and Q_L of Figure 5) of each output are off.

V_D

This pin allows for provision of a current path for the motor coil current during switching, in order to suppress back-EMF voltage spikes. V_D is normally connected to V_M (Pin 16) through a diode (zener or regular), a resistor, or directly. The peaks instantaneous voltage at the outputs must not exceed V_M by more than 6.0 V. The voltage drop across the internal clamping diodes must be included in this portion of the design (see Figure 6). Note the parasitic diodes (Figure 5) across each Q_L of each output provide for a complete circuit path for the switched current.

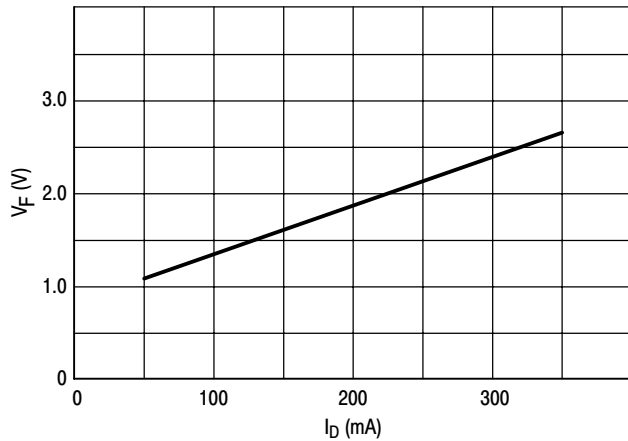

Figure 6. Clamp Diode Characteristics

Full/Half Step

When this input is at a Logic “0” (< 0.8 V), the outputs change a full step with each clock cycle, with the sequence direction depending on the \overline{CW}/CCW input. There are four steps ($\overline{\text{Phase A}}$, $\overline{\text{B}}$, $\overline{\text{C}}$, $\overline{\text{D}}$) for each complete cycle of the sequencing logic. Current flows through both motor coils during each step, as shown in Figure 7.

When taken to a Logic “1” (>2.0 V), the outputs change a half step with each clock cycle, with the sequence direction depending on the \overline{CW}/CCW input. Eight steps ($\overline{\text{Phase A}}$ to $\overline{\text{H}}$) result for each complete cycle of the sequencing logic. $\overline{\text{Phase A}}$, $\overline{\text{C}}$, $\overline{\text{E}}$ and $\overline{\text{G}}$ correspond (in polarity) to $\overline{\text{Phase A}}$, $\overline{\text{B}}$, $\overline{\text{C}}$, and $\overline{\text{D}}$, respectively, of the full step sequence. $\overline{\text{Phase B}}$, $\overline{\text{D}}$, $\overline{\text{F}}$ and $\overline{\text{H}}$ provide current to one motor coil, while de-energizing the other coil. The condition of the outputs of the de-energized coil depends on the OIC input, see Figure 7 timing diagram.

OIC

The output impedance control input determines the output impedance to the de-energized coil when operating in the half-step mode. When the outputs are in $\overline{\text{Phase B}}$, $\overline{\text{D}}$, $\overline{\text{F}}$ or $\overline{\text{H}}$ (Figure 7) and this input is at a Logic “0” (<0.8 V), the two outputs to the de-energized coil are in a high impedance condition – Q_L and Q_H of both outputs (Figure 5) are off. When this input is at a Logic “1” (>2.0 V), a low impedance output is provided to the de-energized coil as both outputs have Q_H on (Q_L off). To complete the low impedance path requires connecting V_D to V_M as described elsewhere in this data sheet.

Bias/Set

This pin can be used for three functions: a) determining the maximum output sink current; b) setting the internal logic to a known state; and c) reducing power consumption.

a) The maximum output sink current is determined by the base drive current supplied to the lower transistors (Q_Ls of Figure 5) of each output, which in turn, is a function of I_{BS}. The appropriate value of I_{BS} can be approximated using Figure 11.

MC3479

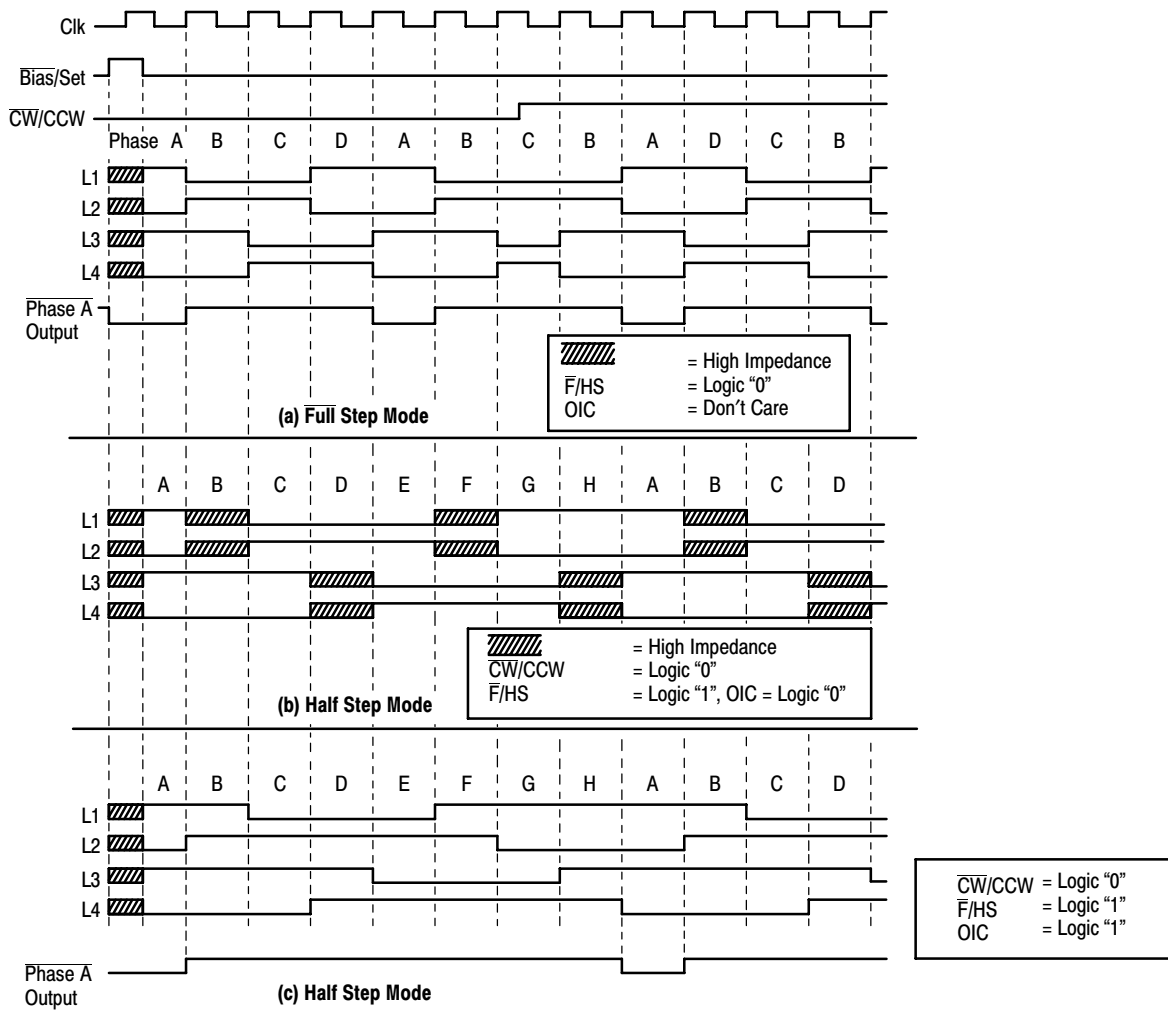

Figure 7. Output Sequence

The value of R_B (between this pin and ground) is then determined by:

$$R_B = \frac{V_M - 0.7 V}{I_{BS}}$$

b) When this pin is opened (raised to V_M) such that $I_{BS} < 5.0 \mu A$, the internal logic is set to the Phase A condition, and the four driver outputs are put into a high impedance state. The Phase A output (Pin 11) goes active (low), and input signals at the controls are ignored during this time. Upon re-establishing I_{BS} , the driver outputs become active, and will be in the Phase A position ($L1 = L3 = V_{OHD}$, $L2 = L4 = V_{OLD}$). The circuit will then respond to the inputs at the controls.

The Set function (opening this pin) can be used as a power reset while supply voltages are settling. A CMOS logic gate (powered by V_M) can be used to control this pin as shown in Figure 12.

c) Whenever the motor is not being stepped, power dissipation in the IC and in the motor may be lowered by reducing I_{BS} , so as to reduce the output (motor) current. Setting I_{BS} to $75 \mu A$ will reduce the motor current, but will not reset the internal logic as described above. See Figure 13 for a suggested circuit.

Power Dissipation

The power dissipated by the MC3479 must be such that the junction temperature (T_J) does not exceed $150^\circ C$. The power dissipated can be expressed as:

$$P = (V_M \times I_M) + (2 \times I_{OD}) [(V_M - V_{OHD}) + V_{OLD}]$$

where

V_M = Supply voltage;

I_M = Supply current other than I_{OD} ;

I_{OD} = Output current to each motor coil;

V_{OHD} = Driver output high voltage;

V_{OLD} = Driver output low voltage.

The power supply current (I_M) is obtained from Figure 8. After the power dissipation is calculated, the junction temperature can be calculated using:

$$T_J = (P \times R_{\theta JA}) + T_A$$

where $R_{\theta JA}$ = Junction-to-ambient thermal resistance ($52^\circ C/W$ for the DIP, $72^\circ C/W$ for the FN Package);

T_A = Ambient Temperature.

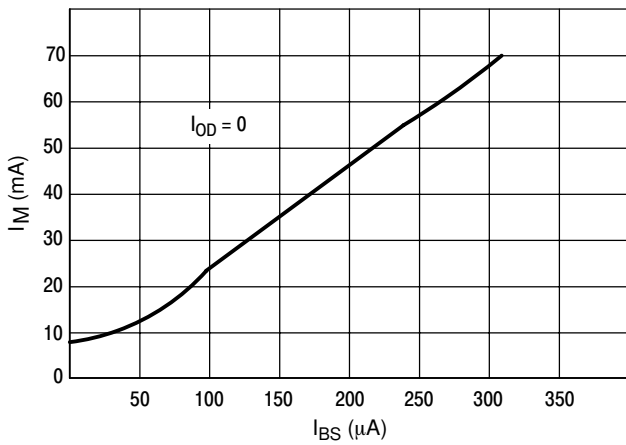

Figure 8. Power Supply Current

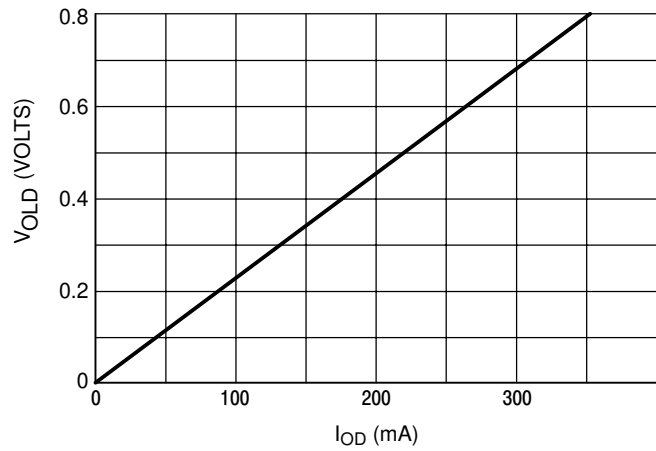

Figure 9. Maximum Saturation Voltage – Driver Output Low

For example, assume an application where $V_M = 12\text{ V}$, the motor requires 200 mA/coil, operating at room temperature with no heatsink on the IC. From Figure 11, I_{BS} is determined to be 95 μA .

R_B is calculated:

$$R_B = (12 - 0.7)\text{ V} / 95\ \mu\text{A}$$

$$R_B = 118.9\ \text{k}\Omega$$

From Figure 8, I_M (max) is determined to be 22 mA. From Figure 9, V_{OLD} is 0.46 V, and from Figure 10, $(V_M - V_{OHD})$ is 1.4 volts.

$$P = (12 \times 0.022) + (2 \times 0.2) (1.4 + 0.46)$$

$$P = 1.01\text{ W}$$

$$T_J = (1.01\text{ W} \times 52^\circ\text{C/W}) + 25^\circ\text{C}$$

$$T_J = 77.5^\circ\text{C}$$

This temperature is well below the maximum limit. If the calculated T_J had been higher than 150°C , a heatsink such as the Staver Co. V-7 Series, Aavid #5802, or Thermalloy #6012 could be used to reduce $R_{\theta JA}$. In extreme cases, forced air cooling should be considered.

The above calculation, and $R_{\theta JA}$, assumes that a ground plane is provided under the MC3479 (either or both sides of the PC board) to aid in the heat dissipation. Single nominal width traces leading from the four ground pins should be avoided as this will increase T_J , as well as provide potentially disruptive ground noise and I_R drops when switching the motor current.

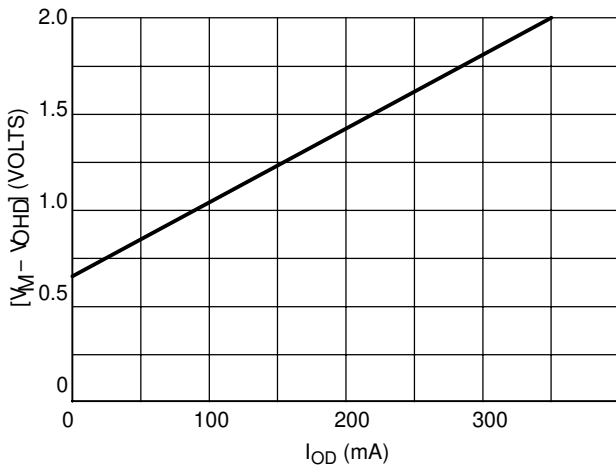

Figure 10. Maximum Saturation Voltage – Driver Output High

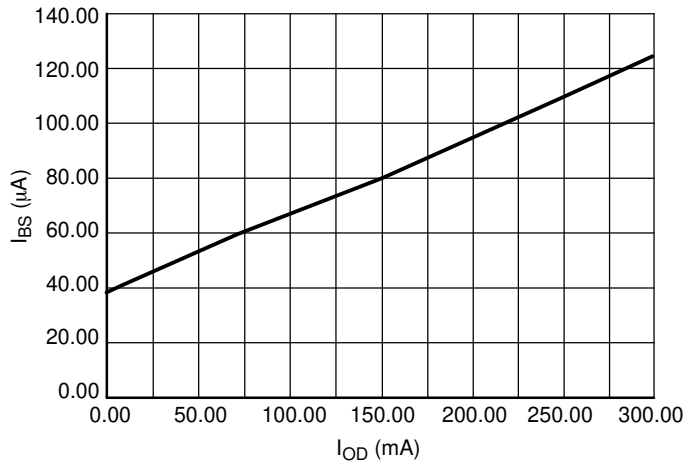

Figure 11. Bias/Set Current – Output Drive Current

MC3479

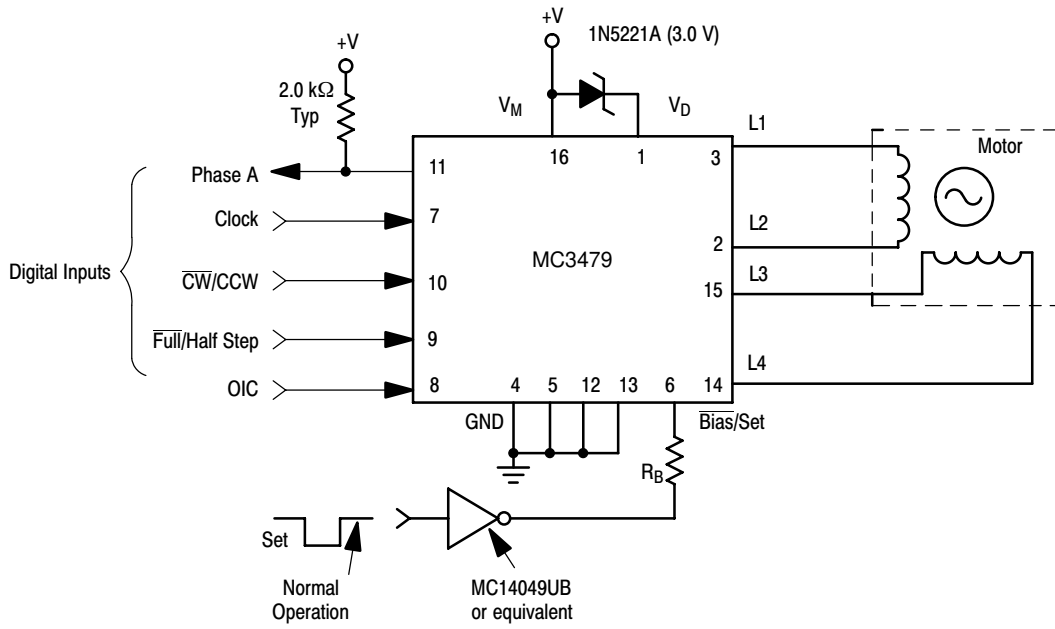
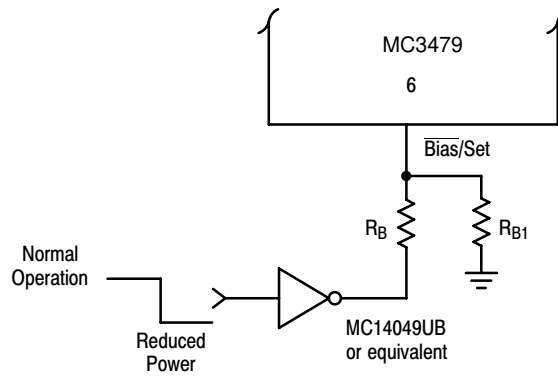

Figure 12. Typical Applications Circuit



- Suggested value for R_{B1} ($V_M = 12\text{ V}$) is $150\text{ k}\Omega$.
- R_B calculation (see text) must take into account the current through R_{B1} .

Figure 13. Power Reduction

MC3479

PACKAGE DIMENSIONS

PDIP-16
CASE 648C-04
ISSUE D

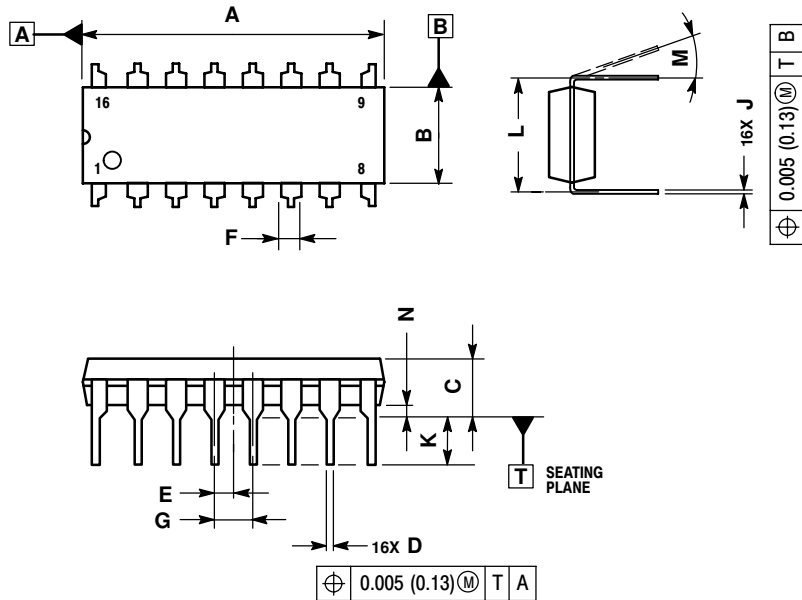

NOTES:

1. DIMENSIONING AND TOLERANCING PER ASME Y14.5M, 1994.
2. CONTROLLING DIMENSION: INCH.
3. DIMENSION L TO CENTER OF LEADS WHEN FORMED PARALLEL.
4. DIMENSION B DOES NOT INCLUDE MOLD FLASH.

DIM	INCHES		MILLIMETERS	
	MIN	MAX	MIN	MAX
A	0.744	0.783	18.90	19.90
B	0.240	0.260	6.10	6.60
C	0.145	0.185	3.69	4.69
D	0.015	0.021	0.38	0.53
E	0.050 BSC		1.27 BSC	
F	0.040	0.70	1.02	1.78
G	0.100 BSC		2.54 BSC	
J	0.008	0.015	0.20	0.38
K	0.115	0.135	2.92	3.43
L	0.300 BSC		7.62 BSC	
M	0°	10°	0°	10°
N	0.015	0.040	0.39	1.01

ON Semiconductor and are registered trademarks of Semiconductor Components Industries, LLC (SCILLC). SCILLC reserves the right to make changes without further notice to any products herein. SCILLC makes no warranty, representation or guarantee regarding the suitability of its products for any particular purpose, nor does SCILLC assume any liability arising out of the application or use of any product or circuit, and specifically disclaims any and all liability, including without limitation special, consequential or incidental damages. "Typical" parameters which may be provided in SCILLC data sheets and/or specifications can and do vary in different applications and actual performance may vary over time. All operating parameters, including "Typicals" must be validated for each customer application by customer's technical experts. SCILLC does not convey any license under its patent rights nor the rights of others. SCILLC products are not designed, intended, or authorized for use as components in systems intended for surgical implant into the body, or other applications intended to support or sustain life, or for any other application in which the failure of the SCILLC product could create a situation where personal injury or death may occur. Should Buyer purchase or use SCILLC products for any such unintended or unauthorized application, Buyer shall indemnify and hold SCILLC and its officers, employees, subsidiaries, affiliates, and distributors harmless against all claims, costs, damages, and expenses, and reasonable attorney fees arising out of, directly or indirectly, any claim of personal injury or death associated with such unintended or unauthorized use, even if such claim alleges that SCILLC was negligent regarding the design or manufacture of the part. SCILLC is an Equal Opportunity/Affirmative Action Employer. This literature is subject to all applicable copyright laws and is not for resale in any manner.

PUBLICATION ORDERING INFORMATION

LITERATURE FULFILLMENT:
Literature Distribution Center for ON Semiconductor
P.O. Box 5163, Denver, Colorado 80217 USA
Phone: 303-675-2175 or 800-344-3860 Toll Free USA/Canada
Fax: 303-675-2176 or 800-344-3867 Toll Free USA/Canada
Email: orderlit@onsemi.com

N. American Technical Support: 800-282-9855 Toll Free USA/Canada
Europe, Middle East and Africa Technical Support:
Phone: 421 33 790 2910
Japan Customer Focus Center
Phone: 81-3-5773-3850

ON Semiconductor Website: www.onsemi.com
Order Literature: <http://www.onsemi.com/orderlit>
For additional information, please contact your local Sales Representative