

Chipsmall Limited consists of a professional team with an average of over 10 year of expertise in the distribution of electronic components. Based in Hongkong, we have already established firm and mutual-benefit business relationships with customers from,Europe,America and south Asia,supplying obsolete and hard-to-find components to meet their specific needs.

With the principle of “Quality Parts,Customers Priority,Honest Operation,and Considerate Service”,our business mainly focus on the distribution of electronic components. Line cards we deal with include Microchip,ALPS,ROHM,Xilinx,Pulse,ON,Everlight and Freescale. Main products comprise IC,Modules,Potentiometer,IC Socket,Relay,Connector.Our parts cover such applications as commercial,industrial, and automotives areas.

We are looking forward to setting up business relationship with you and hope to provide you with the best service and solution. Let us make a better world for our industry!



Contact us

Tel: +86-755-8981 8866 Fax: +86-755-8427 6832

Email & Skype: info@chipsmall.com Web: www.chipsmall.com

Address: A1208, Overseas Decoration Building, #122 Zhenhua RD., Futian, Shenzhen, China

High-speed CAN Transceiver

The MC33901/34901 are SMARTMOS high-speed (up to 1.0 Mb/s) CAN transceivers providing the physical interface between the CAN protocol controller of an MCU and the physical dual wires CAN bus. They are packaged in an 8-pin SOIC with market standard pinout, and offer excellent EMC and ESD performance without the need for external filter components.

Four device variations are available:

- Versions with and without CAN bus wake-up.
- Versions with and without TXD dominant protection.

Features

- Very low-current consumption in standby mode
- Compatible with 3.3 V or 5.0 V MCU interface
- Standby mode with remote CAN wake-up on some versions.
- Pin and function compatible with market standard

Cost efficient robustness:

- High system level ESD performance
- Very high electromagnetic immunity and low electromagnetic emission without common mode choke or other external components.

Fail-safe behaviors:

- TXD Dominant timeout, on the 33901 version.
- Ideal passive when unpowered, CAN bus leakage current <10 μ A.
- V_{DD} and V_{IO} monitoring

33901
34901

HIGH-SPEED CAN TRANSCEIVER

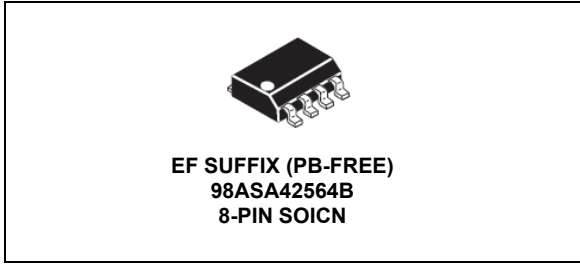

Industrial Applications (MC34901)

- Transportation
- Backplanes
- Lift/elevators
- Factory automation
- Industrial process control

Automotive Applications (MC33901)

- Supports automotive CAN high-speed applications
- Body electronics
- Power train
- Chassis and safety
- Infotainment
- Diagnostic equipment
- Accessories

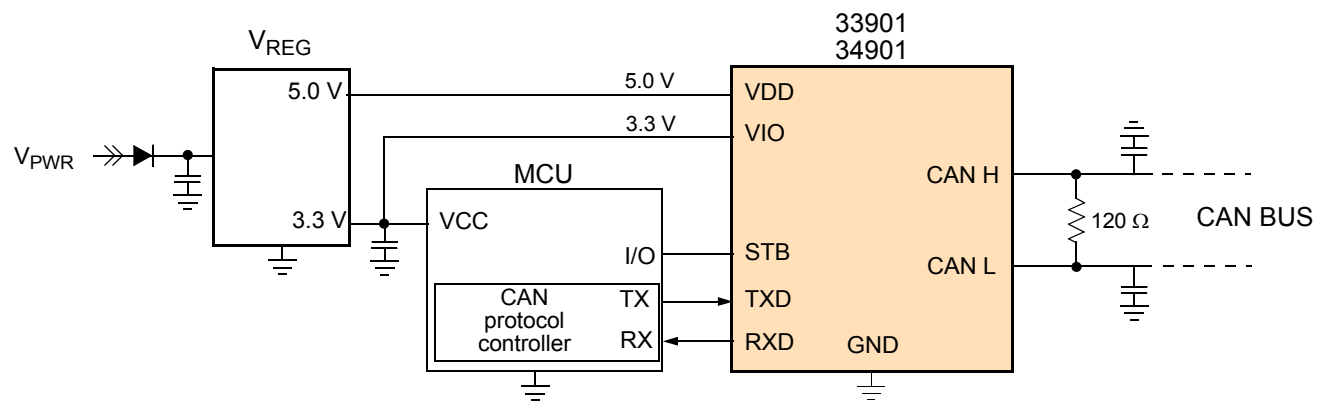

Figure 1. Simplified Application Diagram for MC3x901xEF

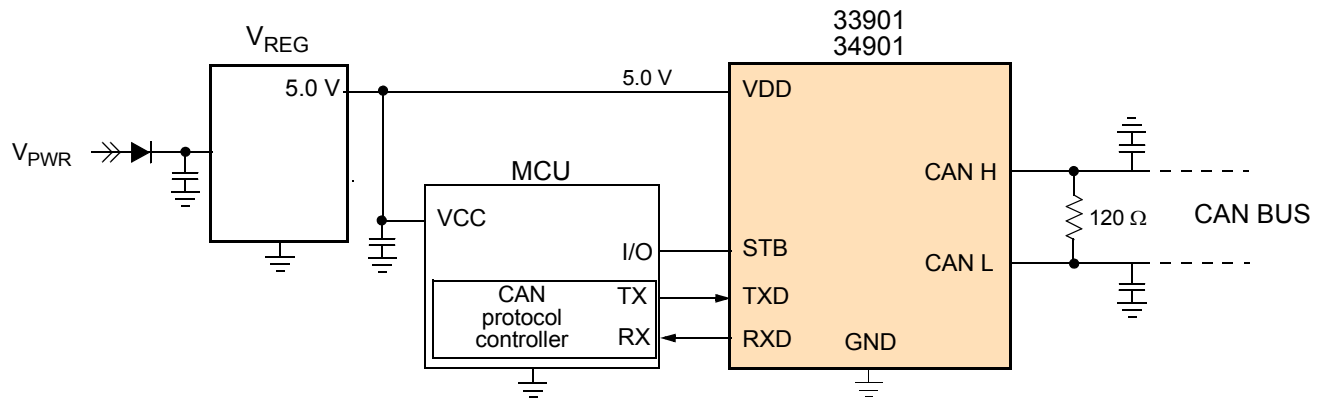

Figure 2. Simplified Application Diagram for MC3x901xNEF



Table of Contents

1	Orderable Parts	4
2	Internal Block Diagram	5
3	Pin Connections	6
3.1	Pinout	6
3.2	Pin Definitions	6
3.3	Maximum Ratings	7
3.4	Thermal Characteristics	7
3.5	Operating Conditions	8
4	General IC Functional Description and Application Information	9
4.1	Introduction	9
4.2	Pin Function and Description	9
4.3	Operating Modes	10
4.4	Fail-safe Mechanisms	10
4.5	Device Operation Summary	12
4.6	Electrical Characteristics	14
5	Typical Applications	19
5.1	Application Diagrams	19
6	Packaging	21
6.1	Package Mechanical Dimensions	21
7	Revision History	23



1 Orderable Parts

This section describes the part numbers available to be purchased along with their differences.

Table 1. Orderable Part Variations

Part Number ⁽¹⁾	Temperature (T _A)	Package	VIO	Wake-up Function	TXD dominant protection
MC33901WEF	-40 to 125 °C	SOIC 8 pins	Yes	Available	Available
MC33901WNEF			No		
MC33901SEF			Yes	Not Available	
MC33901SNEF			No		
MC34901WEF			Yes	Available	Not Available
MC34901WNEF			No		
MC34901SEF			Yes	Not Available	
MC34901SNEF			No		

Notes

1. To order parts in Tape & Reel, add the R2 suffix to the part number.

Valid orderable part numbers are provided on the web. To determine the orderable part numbers for this device, go to <http://www.freescale.com> and perform a part number search.

2 Internal Block Diagram

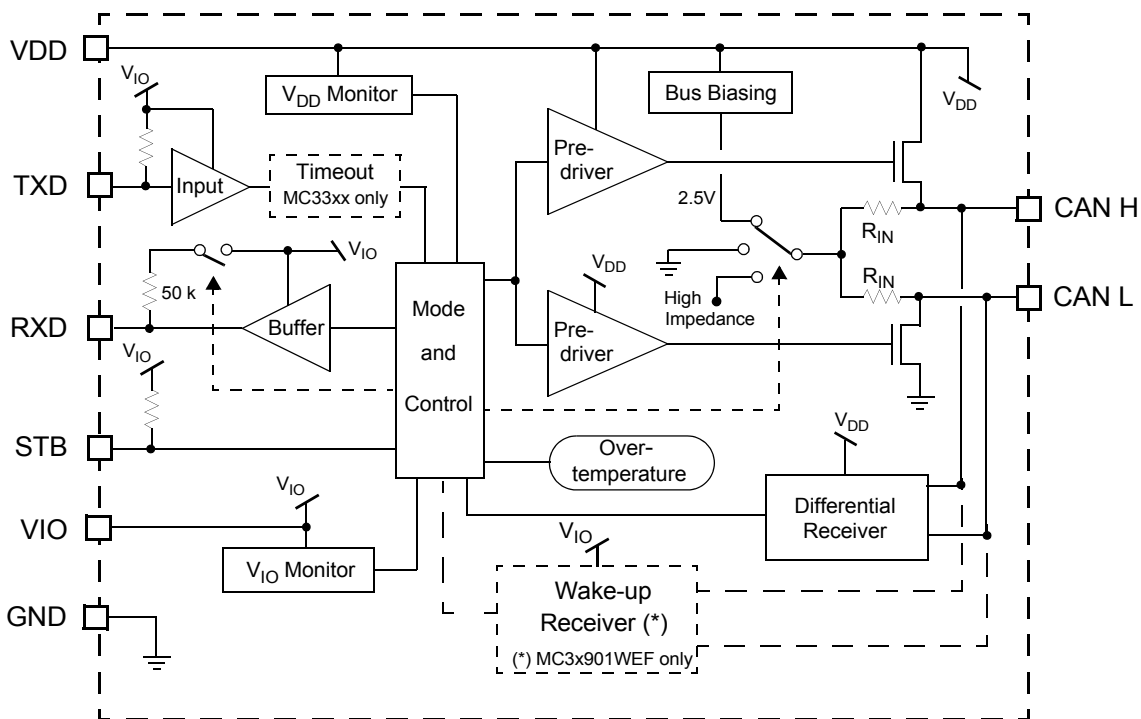

Figure 3. Internal Block Diagram for MC3x901xEF

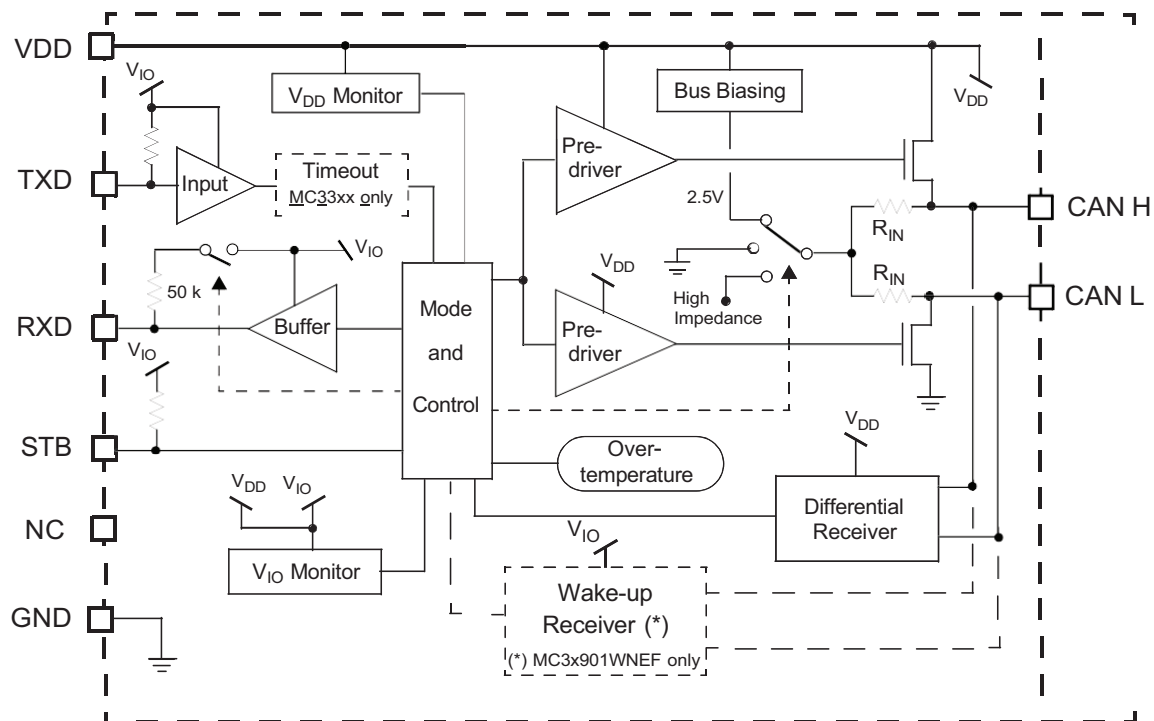

Figure 4. Internal Block Diagram for MC3x901xNEF (Version N)

3 Pin Connections

3.1 Pinout



Figure 5. 8-Pin SOIC Pinout

3.2 Pin Definitions

A functional description of each pin can be found in the Functional Pin Description section beginning on [page 9](#).

Table 2. 33901 Pin Definitions

Pin Number	MC3x901xEF Pin Name	MC3x901xNEF Pin Name	Pin Function	Definition
1	TXD	TXD	Input	CAN bus transmit data input pin
2	GND	GND	Ground	Ground
3	VDD	VDD	Input	5.0 V input supply for CAN driver and receiver
4	RXD	RXD	Output	CAN bus receive data output pin
5	VIO	NC	Input or Not connected	Input supply for the digital input output pins (MC3x901WEF and MC3x901SEF) or Not connected pin (MC3x901WNEF and MC3x901SNEF)
6	CAN L	CAN L	Input/Output	CAN bus low pin
7	CAN H	CAN H	Input/Output	CAN bus high pin
8	STB	STB	Input	Standby input for device mode selection

3.3 Maximum Ratings

Table 3. Maximum Ratings

All voltages are with respect to ground unless otherwise noted. Exceeding these ratings may cause a malfunction or permanent damage to the device.

Symbol	Description (Rating)	Min.	Max.	Unit	Notes
ELECTRICAL RATINGS					
V_{DD}	V_{DD} Logic Supply Voltage	-0.3	7.0	V	
V_{IO}	Input/Output Logic Voltage	-0.3	7.0	V	
V_{STB}	Standby pin Input Voltage	-0.3	7.0	V	
V_{TXD}	TXD maximum voltage range	-0.3	7.0	V	
V_{RXD}	RXD maximum voltage range	-0.3	7.0	V	
V_{CANH}	CANH Bus pin maximum range	-27	40	V	
V_{CANL}	CANL Bus pin maximum range	-27	40	V	
V_{ESD}	ESD Voltage <ul style="list-style-type: none"> • Human Body Model (HBM) (all pins except CANH and CANL pins) • Human Body Model (HBM) (CANH, CANL pins) • Machine Model (MM) • Charge Device Model (CDM)/(corners pins) • System level ESD <ul style="list-style-type: none"> • 330 Ω/150 pF Unpowered According to IEC61000-4-2: • 330 Ω/150 pF Unpowered According to OEM LIN, CAN, Flexray Conformance • 2.0 kΩ/150 pF Unpowered According to ISO10605.2008 • 2.0 kΩ/330 pF Powered According to ISO10605.2008 		±2000 ±8000 ±200 ±500/(±750)	V kV	(2)

Notes

- ESD testing is performed in accordance with the Human Body Model (HBM) ($C_{ZAP} = 100$ pF, $R_{ZAP} = 1500$ Ω), the Machine Model (MM) ($C_{ZAP} = 200$ pF, $R_{ZAP} = 0$ Ω), and the Charge Device Model.

3.4 Thermal Characteristics

Table 4. Thermal Ratings

Symbol	Description (Rating)	Min.	Max.	Unit	Notes
THERMAL RATINGS					
T_A	Operating Temperature	-40	125	°C	
T_J	• Ambient • Junction	-40	150		
T_{STG}	Storage Temperature	-55	150	°C	
T_{PPRT}	Peak Package Reflow Temperature During Reflow	–	–	°C	
THERMAL RESISTANCE AND PACKAGE DISSIPATION RATINGS					
$R_{\theta JA}$	Junction-to-Ambient, Natural Convection, Single-Layer Board	–	140	°C/W	
T_{SD}	Thermal Shutdown	150	–	°C	
T_{SDH}	Thermal Shutdown Hysteresis	–	15	°C	

3.5 Operating Conditions

This section describes the operating conditions of the device. Conditions apply to all the following data, unless otherwise noted.

Table 5. Operating Conditions

All voltages are with respect to ground unless otherwise noted. Exceeding these ratings may cause a malfunction or permanent damage to the device.

Symbol	Ratings	Min	Max	Unit	Notes
V_{DD_F}	Functional operating V_{DD} voltage	V_{DD_UV}	7.0	V	
V_{DD_OP}	Parametric operating V_{DD} voltage	4.5	5.5	V	
V_{IO_F}	Functional operating V_{IO} voltage	V_{IO_UV}	7.0	V	
V_{IO_OP}	Parametric operating V_{IO} voltage	2.8	5.5	V	

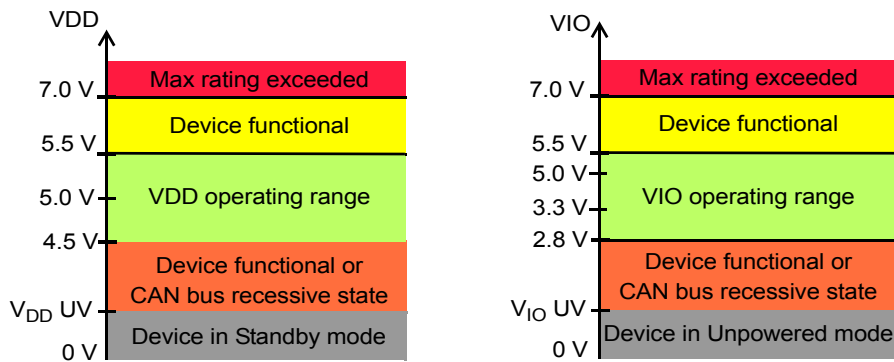

Figure 6. Supply Voltage Operating Range

4 General IC Functional Description and Application Information

4.1 Introduction

The 33901/34901 are high speed CAN transceivers providing the physical interface between the CAN protocol controller of an MCU and the physical dual wires CAN bus. They are packaged in an 8-pin SOIC with market standard pinout, and offer excellent EMC and ESD performance without the need for external filter components. They meet the ISO 11898-2 and ISO11898-5 standards, and have low leakage on CAN bus while unpowered.

The devices are supplied from VDD and VIO, to allow automatic operation with 5.0 V and 3.3 V microcontrollers. They are offered in four versions: with and without CAN bus wake-up, and with and without TXD dominant timeout.

- MC3x901xEF devices are supplied from VDD and VIO, to allow automatic operation with 5.0 V and 3.3 V microcontrollers.
- MC3x901xNEF devices are supplied from VDD, to allow operation with 5.0 V microcontrollers.

They are offered in eight versions: with and without CAN bus wake-up, with and without TXD dominant time out, and with or without external VIO.

4.2 Pin Function and Description

4.2.1 VDD Power Supply

This is the supply for the CANH and CANL bus drivers, the bus differential receiver and the bus biasing voltage circuitry. VDD is monitored for under voltage conditions. See [Fail-safe Mechanisms](#). When the device is in standby mode, the consumption on VDD is extremely low (Refer to [IVDD](#)).

4.2.2 VIO Digital I/O Power Supply

This is the supply for the TXD, RXD, and STB digital input outputs pins. VIO also supplies the low-power differential wake-up receivers and filter circuitry. This allows detecting and reporting bus wake-up events with device supplied only from VIO. VIO is monitored for undervoltage conditions. See [Fail-safe Mechanisms](#). When the device is in Standby mode, the consumption on VIO is extremely low (Refer to [IVIO](#)). V_{IO} is internally connected to VDD for the MC3x901xNEF.

4.2.3 STB

STB is the input pin to control the device mode. When STB is high or floating, the device is in Standby mode. When STB is low, the device is set in Normal mode. STB has an internal pull-up to VIO, so if STB is left open, the device is set to a predetermined Standby mode.

4.2.4 TXD

TXD is the device input pin to control the CAN bus level. In the application, this pin is connected to the microcontroller transmit terminal. In Normal mode, when TXD is high or floating, the CANH and CANL drivers are OFF, setting the bus in a recessive state. When TXD is low, the CANH and CANL drivers are activated and the bus is set to a dominant state. TXD has a built-in timing protection that disables the bus when TXD is dominant for more than t_{XDOM} .

In Standby mode, TXD has no effect on the device. The TXD dominant protection is available on 33901, but not available on 34901.

4.2.5 RXD

RXD is the bus output level report pin. In the application, this pin is connected to the microcontroller receive terminal. In Normal mode, RXD is a push-pull structure. When the bus is in a recessive state, RXD is high. When the bus is dominant, RXD is low.

In Standby mode, the push-pull structure is disabled, RXD is pulled up to VIO via a resistor (R_{PU-RXD}), and is in a high level. When the bus wake-up is detected, the push-pull structure resumes and TXD reports a wake-up via a toggling mechanism (refer to [Figure 10](#)). The toggling mechanism for bus wake-up reports is available on the MC33901WEF. This mechanism is not available on the MC33901SEF.

4.2.6 CANH and CANL

These are the CAN bus terminals.

CANL is a low side driver to GND, and CANH is a high-side driver to VDD. In Normal mode and TXD high, the CANH and CANL drivers are OFF, and the voltage at CANH and CANL is approx. 2.5 V, provided by the internal bus biasing circuitry. When TXD is low, CANL is pulled to GND and CANH to VDD, creating a differential voltage on the CAN bus.

In Standby mode, CANH and CANL drivers are OFF, and these pins are pulled to GND via the device R_{IN} resistor for the MC3x901WEF versions (ref to parameter [Input resistance](#)). In device unpowered mode, CANH and CANL are high-impedance with extremely low leakage to GND, making the device ideally passive when unpowered.

CANH and CANL have integrated ESD protection and extremely high robustness versus external disturbance, such as EMC and electrical transients. These pins have current limitation and thermal protection.

4.3 Operating Modes

The device has two operating modes: Standby and Normal.

4.3.1 Normal Mode

This mode is selected when the STB pin is low. In this mode, the device is able to transmit information from TXD to the bus and report the bus level to the RXD pin. When TXD is high, CANH and CANL drivers are off and the bus is in the recessive state (unless it is in an application where another device drives the bus to the dominant state). When TXD is low, CANH and CANL drivers are ON and the bus is in the dominant state.

4.3.2 Standby Mode

This mode is selected when the STB pin is high or floating. In this mode, the device is not able to transmit information from TXD to the bus, and it cannot report accurate bus information. The Device can only report bus wake-up events via the RXD toggling mechanism.

The bus wake-up report is available on the MC3x901WEF and MC3x901WNEF. This feature is not available on the MC3x901SEF. In Standby mode, the consumption from VDD and VIO is extremely low. In this mode, the CANH and CANL pins are pulled to GND via the internal R_{IN} resistor, for device versions MC33901WEF and MC34901WNEF.

4.3.2.1 Wake-up Mechanism

The device versions MC3x901WEF and MC34901WNEF include bus monitoring circuitry to detect and report bus wake-ups. To activate a wake-up report, three events must occur on the CAN bus:

- event 1: a dominant level for a time longer than t_{WU_FLT1} followed by
- event 2: a recessive level (event 2) longer than t_{WU_FLT2} followed by
- event 3: a dominant level (event 3) longer than t_{WU_FLT2} .

The RXD terminal then reports the bus state (bus dominant => RXD low, bus recessive => RXD high). The delay between bus dominant and RXD low, and bus recessive and RXD high is longer than in Normal mode (refer to t_{TGLT}).

The three events must occur within the t_{WU_TO} timeout.

[Figure 10](#) illustrates the wake-up detection and reporting (toggling) mechanism. If the three events do not occur within the T_{WU_TO} timeout, the wake-up and toggling mechanism are not active. This is illustrated in [Figure 11](#).

The three events and the timeout function avoid a permanent dominant state on the bus that would generate a permanent wake-up situation, which would prevent the system from entering low power mode.

4.3.3 Unpowered Mode

When VIO is below V_{IO_UV} , the device is in unpowered mode. The CAN bus is in high-impedance and is unable to transmit, receive, or report bus wake-up events.

4.4 Fail-safe Mechanisms

The device implements various protection, detection, and predictable fail-safe mechanisms.

4.4.1 STB and TXD Input Pins

The STB input pin has an internal integrated pull-up structure to the VIO supply pin. If STB is open, the device is set to Standby mode to ensure predictable behavior and minimize system current consumption.

The TXD input pin also has an internal integrated pull-up structure to the VIO supply pin. If TXD is open, the CAN driver is set to the recessive state to minimize current consumption and ensure that no false dominant bit is transmitted on the bus.

4.4.2 TXD Dominant Timeout Detection

If TXD is set low for a time longer than the `TXD_DOM` parameter, the CAN drivers are disabled and the CAN bus returns to recessive state. This prevents the bus from being set to the dominant state permanently in case a fault sets the TXD input to low level permanently.

The device recovers from this when a high level is detected on TXD. Refer to [Figures 12](#).

4.4.3 CAN Current Limitation

The current flowing in and out of the CANH and CANL driver is limited to a maximum of 100 mA, in case of a short-circuit (parameter for `ILIM`).

4.4.4 CAN Overtemperature

If the driver temperature exceeds `TSD`, the driver is turned off to protect the device. A hysteresis is implemented in this protection feature. The device overtemperature and recovery conditions are shown in [Figure 7 “Overtemperature behavior”](#). The driver remains disabled until the temperature has fallen below the OT threshold minus the hysteresis and a TXD high to low transition is detected.

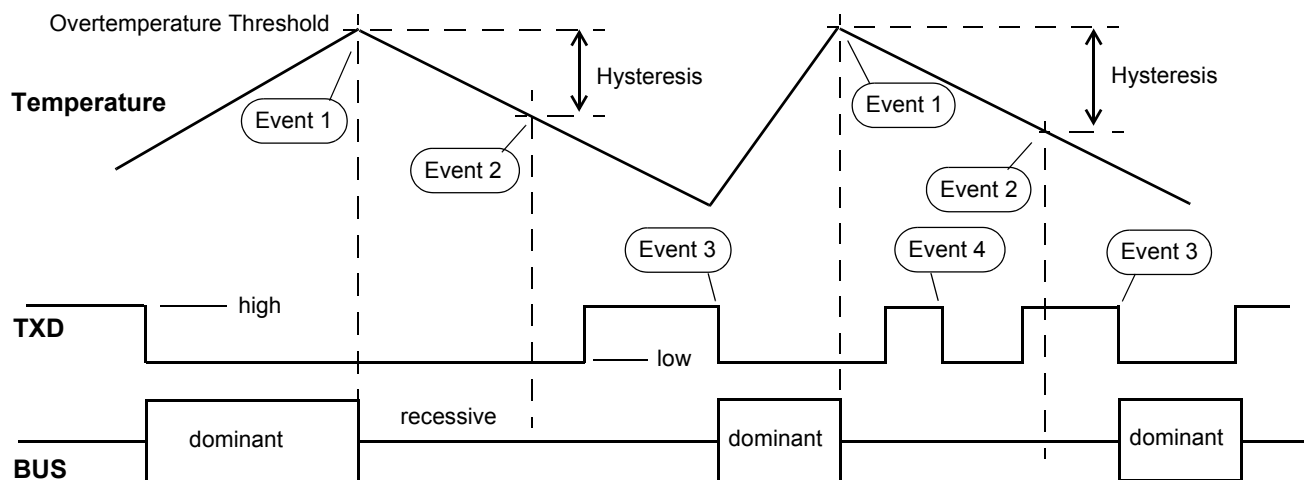

Event 1: overtemperature detection. CAN driver disable.

Event 2: temperature falls below “overtemperature threshold minus hysteresis” => CAN driver remains disable.

Event 3: temperature below “overtemperature threshold minus hysteresis” and TxD high to low transition => CAN driver enable.

Event 4: temperature above “overtemperature threshold minus hysteresis” and TxD high to low transition => CAN driver remains disable.

Figure 7. Overtemperature behavior

4.4.5 VDD and VIO Supply Voltage Monitoring

For MC3x901WEF and MC3x901SEF versions:

The device monitors the VDD and VIO supply inputs. If V_{DD} falls below $V_{DD_{UV}}$ (`VDD_UV`), the device is set in Standby mode. This ensures a predictable behavior due to the loss of V_{DD} . CAN driver, receiver, or bus biasing cannot operate any longer. In this case, the bus wake-up is available as V_{IO} remains active.

If V_{IO} falls below $V_{IO_{UV}}$ (`VIO_UV`), the device is set to an unpowered condition. This ensures a predictable behavior due to the loss of V_{IO} . CAN driver, receiver, or bus biasing can not operate any longer. This sets the bus in high-impedance and in ideal passive behavior.

For MC3x901WNEF and MC3x901SNEF versions:

As V_{IO} is internally connected to V_{DD} , V_{IO} voltage depends on the V_{DD} supply. If V_{DD} is between V_{IO_UV} and V_{DD_UV} , the device is set in Standby mode. If V_{DD} is below V_{IO_UV} , the device is set in unpowered mode.

4.4.6 Bus Dominant State Behavior in Standby Mode

In device Standby mode, a bus dominant condition due, for instance to a short-circuit or a fault in one of the other CAN nodes, does not generate a permanent wake-up event, by virtue of the multiple events (dominant, recessive, dominant) and timeout required to detect and report bus wake-ups.

4.5 Device Operation Summary

The following table summarizes the device operation and the state of the input output pins, depending on the operating mode and power supply conditions.

Table 6. Operation for VIO Devices

STANDBY AND NORMAL MODES FOR MC3X901 VERSION								
MODE	Description	VDD range	VIO range	STB	TXD	RXD	CAN	Wake-up
Normal	Nominal supply and normal mode	from 4.5 V to 5.5 V	from 2.8 V to 5.5 V	Low	TXD High => bus recessive TXD Low => bus dominant	Report CAN state (bus recessive => RXD high, bus dominant => RXD low).	CANH and CANL drivers controlled by TXD input. Differential receiver report bus state on RXD pins. Biasing circuitry provides approx 2.5 in recessive state.	Disabled
Standby	Nominal supply and standby mode	from 0 V to 5.5 V	from 2.8 V to 5.5 V	High or floating	No effect on CAN bus.	Report bus wake up via toggling mechanism for MC3x901WNEF. RXD High level for MC3x901SNEF	CAN driver and differential receiver disabled. Bus biased to GND via internal R_{IN} resistors for MC3x901WNEF. Bus high-impedance for MC3x901SNEF.	Enabled on MC3x901WNEF Not available on MC3x901SNEF
UNDERVOLTAGE AND LOSS OF POWER CONDITIONS FOR MC3X901 VERSION								
MODE	Description	VDD range	VIO range	STB	TXD	RXD	CAN	Wake up
Standby due to VDD loss	Device in standby mode due to loss of VDD (VDD fall below VDD UV)	from 0 V to V_{DD_UV} (4)	from 2.8 V to 5.5 V (5)	X (3)	X	Report bus wake up via toggling mechanism for MC3x901WNEF. RXD High level for MC3x901SNEF	CAN driver and differential receiver disabled. Bus biased to GND via internal R_{IN} resistors for MC3x901WNEF. Bus high-impedance for MC3x901SNEF.	Enabled on MC33901WNEF Not available on MC33901SNEF.
Unpowered due to VIO loss	Device in unpowered state due to low VIO. CAN bus high-impedance	(4)	from 0 V to V_{IO_UV}	X	X	Pulled up to VIO down to VIO approx 1.5 V.	CAN driver and differential receiver disabled. High-impedance, with ideal passive behavior.	Not available.

Notes

3. STB pin has no effect. Device enters in standby mode.
4. VDD consumption < 10 uA down to VDD approx 1.5 V.
5. VIO consumption < 10 uA down to VIO approx 1.5 V. If STB is high or floating.

Table 7. Operation for Non-VIO Devices

STANDBY AND NORMAL MODES FOR MC3X901N VERSIONS							
MODE	Description	VDD range	STB	TXD	RXD	CAN	Wake-up
Normal	Nominal supply and normal mode	from 4.5 V to 5.5 V	Low	TXD High => bus recessive TXD Low => bus dominant	Report CAN state (bus recessive => RXD high, bus dominant => RXD low)	CANH and CANL drivers controlled by TXD input. Differential receiver report bus state on RXD pins. Biasing circuitry provides approx 2.5 in recessive state	Disabled
Standby	Nominal supply and standby mode	from 2.8 V to 5.5 V	High or floating	No effect. on CAN bus.	Report bus wake up via toggling mechanism for MC3x901WEF. RXD High level for MC3x901SEF	CAN driver and differential receiver disabled. Bus biased to GND via internal R _{in} resistors for MC3x901WEF. Bus high-impedance for MC3x901SEF	Enabled on MC33901WEF Not available on MC33901SEF

UNDERVOLTAGE AND LOSS OF POWER CONDITIONS FOR MC3X901N VERSIONS							
MODE	Description	VDD range	STB	TXD	RXD	CAN	Wake-up
Unpowered due to VDD loss	Device in unpowered state due to low VDD and so VIO. CAN bus high-impedance	from 0 V to V _{IO_uv}	X	X	Pulled up to VIO down to VIO approx 1.5 V.	CAN driver and differential receiver disabled. High-impedance, with ideal passive behavior	Not available.

4.6 Electrical Characteristics

Table 8. Static Electrical Characteristics

Characteristics noted under conditions $4.5\text{ V} \leq V_{DD} \leq 5.5\text{ V}$, $2.8\text{ V} \leq V_{IO} \leq 5.5\text{ V}$, $-40\text{ }^\circ\text{C} \leq T_A \leq 125\text{ }^\circ\text{C}$, $\text{GND} = 0\text{ V}$, R on CAN bus (R_L) = $60\ \Omega$, unless otherwise noted. Typical values noted reflect the approximate parameter at $T_A = 25\text{ }^\circ\text{C}$ under nominal conditions, unless otherwise noted.

Symbol	Characteristic	Min	Typ	Max	Unit	Notes
POWER INPUT VDD						
V_{DD}	VDD Supply Voltage Range • Nominal Operation	4.5	–	5.5	V	
V_{DD_UV}	V_{DD} Undervoltage threshold	3.0	–	4.5	V	
I_{VDD}	VDD supply current • Normal mode, TXD High • Normal mode, TXD Low • Standby mode (MC3x901) • Standby mode (MC3x901N)	– – – –	– 40 – –	5.0 65 5.0 15	mA mA μA μA	
POWER INPUT VIO						
V_{IO}	Vio Supply Voltage Range • Nominal Operation	2.8	–	5.5	V	
V_{IO_UV}	V_{IO} Under voltage threshold	–	–	2.8	V	
I_{VIO}	VIO supply current • Normal mode, TXD high • Normal mode, TXD low or CAN bus in dominant state • Standby mode, CAN bus in recessive state • Standby mode, wake-up filter and wake-up time out running	– – – –	– – 5.0 –	200 1.0 10 150	μA mA μA μA	
STB INPUT						
V_{STB}	Input voltages • High level Input Voltage • Low level input voltage • Input threshold hysteresis	0.7 – 200	– – –	– 0.3 –	VIO V mV	
R_{PU_STB}	Pull-up resistor to V_{IO}	–	100	–	$\text{k}\Omega$	
TXD INPUT						
V_{TXD}	Input voltages • High level Input Voltage • Low level input voltage • Input threshold hysteresis	0.7 – 200	– – 300	– 0.3 –	VIO V mV	
R_{PU_TXD}	Pull-up resistor to V_{IO}	5.0	–	50	$\text{k}\Omega$	
RXD OUTPUT						
I_{RXD}	Output current • RXD high, VRXD high = $V_{IO} - 0.4\text{ V}$ • RXD low, VRXD high = 0.4 V	-5.0 1.0	-2.5 2.5	-1.0 5.0	mA	
R_{PU_RXD}	Pull-up resistor to V_{IO} (in standby mode, without toggling - no wake-up report)	25	50	90	$\text{k}\Omega$	

Table 8. Static Electrical Characteristics (continued)

Characteristics noted under conditions $4.5\text{ V} \leq V_{DD} \leq 5.5\text{ V}$, $2.8\text{ V} \leq V_{IO} \leq 5.5\text{ V}$, $-40\text{ }^\circ\text{C} \leq T_A \leq 125\text{ }^\circ\text{C}$, $\text{GND} = 0\text{ V}$, R on CAN bus (R_L) = $60\ \Omega$, unless otherwise noted. Typical values noted reflect the approximate parameter at $T_A = 25\text{ }^\circ\text{C}$ under nominal conditions, unless otherwise noted.

Symbol	Characteristic	Min	Typ	Max	Unit	Notes
CANL AND CANH TERMINALS						
V_{REC}	Recessive voltage, TXD high, no load • CANL recessive voltage • CANH recessive voltage	2.0 2.0	2.5 2.5	3.0 3.0	V	
V_{DIFF_REC}	CANH - CANL differential recessive voltage, TXD high, no load	-50	-	50	mV	
V_{REC_SM}	Recessive voltage, sleep mode, no load • CANL recessive voltage • CANH recessive voltage	-0.1 -0.1	- -	0.1 0.1	V	
V_{DOM}	Dominant voltage, TXD low ($t < TX_{DOM}$), $R_L = 45\ \Omega$ to $65\ \Omega$ • CANL dominant voltage • CANH dominant voltage	0.5 2.75	- -	2.25 4.5	V	
V_{DIFF_DOM}	CANH - CANL differential dominant voltage, $R_L = 45\ \Omega$ to $65\ \Omega$, TX_{DLOW}	1.5	2.0	3.0	V	
V_{SYM}	Driver symmetry CANH + CANL	0.9	1.0	1.1	V_{DD}	
I_{LIM}	Current limitation, TXD low ($t < TX_{DOM}$) • CANL current limitation, CANL 5.0 V to 28 V • CANH current limitation, CANH = 0 V	40 -100	- -	100 -40	mA	
V_{DIFF_THR}	CANH - CANL Differential input threshold	0.5	-	0.9	V	
V_{DIFF_HYS}	CANH - CANL Differential input voltage hysteresis	50	-	400	mV	
$V_{DIFF_THR_S}$	CANH - CANL Differential input threshold, in standby mode	0.4	-	1.15	V	
V_{CM}	Common Mode Voltage	-12	-	12	V	
R_{IN}	Input resistance • CANL input resistance • CANH input resistance	5.0 5.0	- -	50 50	k	
R_{IN_DIFF}	CANH, CANL differential input resistance	10	-	100	$k\Omega$	
R_{IN_MATCH}	Input resistance matching	-3.0	-	3.0	%	
I_{IN_UPWR}	CANL or CANH input current, device unpowered, $V_{DD} = V_{IO} = 0\text{ V}$, V_{CANL} and V_{CANH} 0 V to 5.0 V range • V_{DD} connected with $R = 0\text{ k}\Omega$ to GND • V_{DD} connected with $R = 47\text{ k}\Omega$ to GND	-10 -10	- -	10 10	μA	
R_{IN_UPWR}	CANL, CANH input resistance, $V_{CANL} = V_{CANH} = \pm 12\text{ V}$	10	-	-	$k\Omega$	
C_{CAN_CAP}	CANL, CANH input capacitance (guaranteed by design and characterization)	-	20	-	pF	
C_{DIF_CAP}	CANL, CANH differential input capacitance (guaranteed by design and characterization)	-	10	-	pF	
T_{SD}	Temperature Shutdown	150	185	-	$^\circ\text{C}$	

Table 9. Dynamic Electrical Characteristics

Characteristics noted under conditions $4.5\text{ V} \leq V_{DD} \leq 5.5\text{ V}$, $2.8\text{ V} \leq V_{IO} \leq 5.5\text{ V}$, $-40\text{ }^{\circ}\text{C} \leq T_A \leq 125\text{ }^{\circ}\text{C}$, $\text{GND} = 0\text{ V}$, R on CAN bus (R_L) = $60\ \Omega$, unless otherwise noted. Typical values noted reflect the approximate parameter at $T_A = 25\text{ }^{\circ}\text{C}$ under nominal conditions, unless otherwise noted.

Symbol	Characteristic	Min	Typ	Max	Unit	Notes
TIMING PARAMETERS						
$t_{X_{DOM}}$	TXD DOM	2.5	–	16	ms	(6)
t_{LOOP}	T loop	–	–	255	ns	
t_{WU_FLT1}	TWU filter1	0.5	–	5.0	μs	(7)
t_{WU_FLT2}	TWU filter2	0.08	–	1.0	μs	(7)
t_{TGLT}	Tdelay during toggling	–	–	1.3	μs	(7)
t_{WU_TO}	Twake up timeout	1.5	–	7.0	ms	(7)
t_{DELAY_PWR}	Delay between power-up and device ready	–	120	300	μs	
t_{DELAY_SN}	Transition time from Standby to Normal mode (STB high to low)			40	us	

Notes

- 6. MC33901 & MC33901N versions only
- 7. MC3x901WEF and MC3x901WNEF versions only

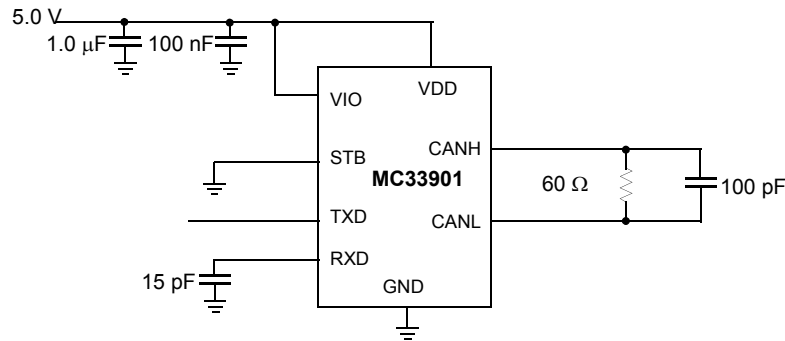

Figure 8. Timing Test Circuit

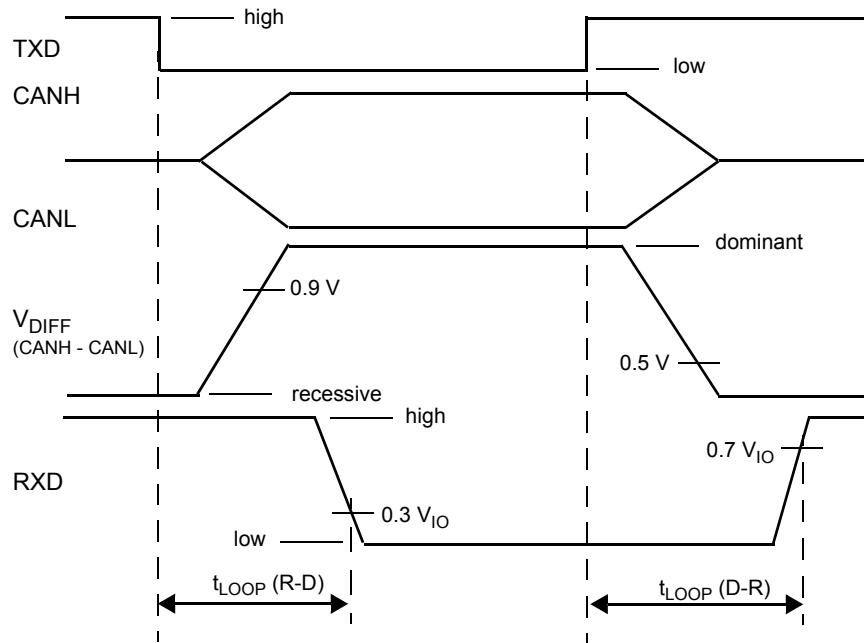

Figure 9. CAN Timing Diagram

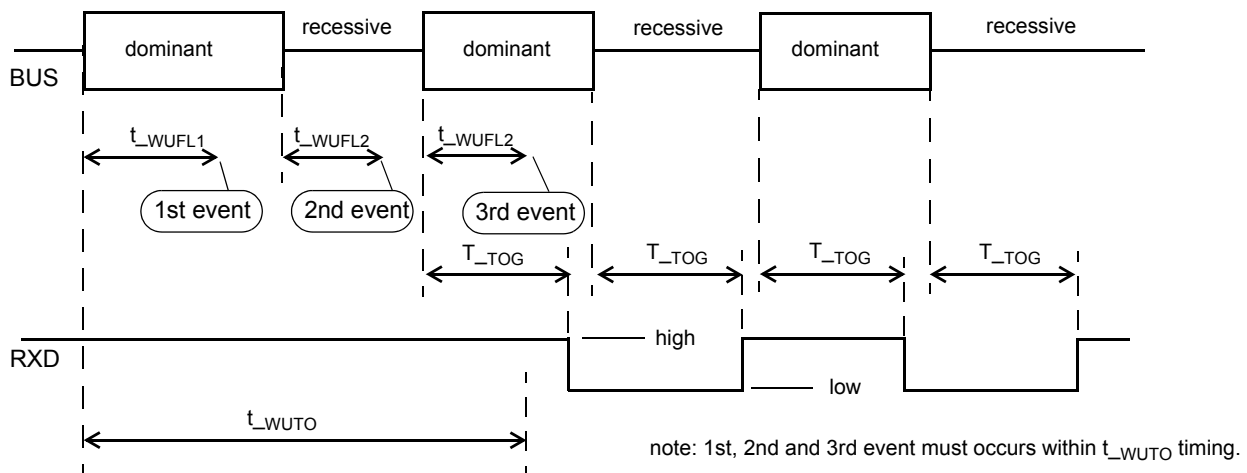

Figure 10. Wake-up Pattern Timing Illustration

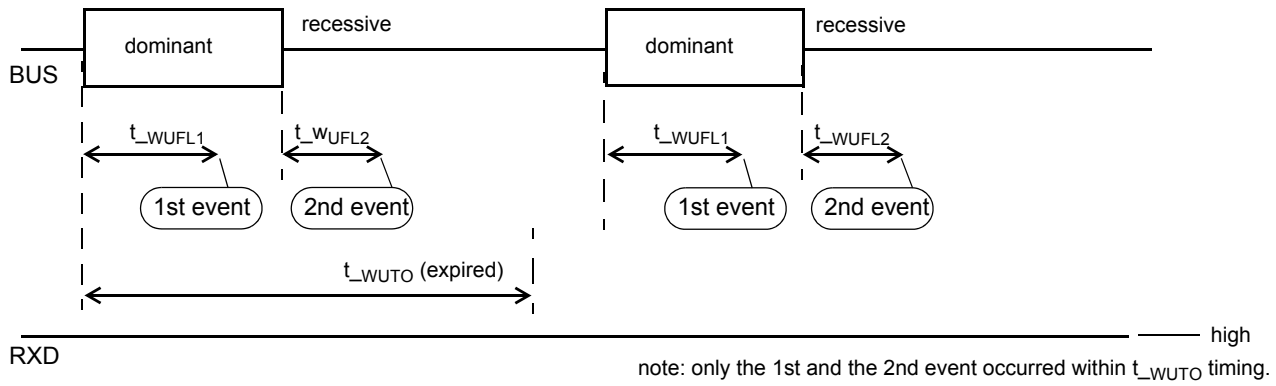

Figure 11. Timeout Wake-up Timing Illustration

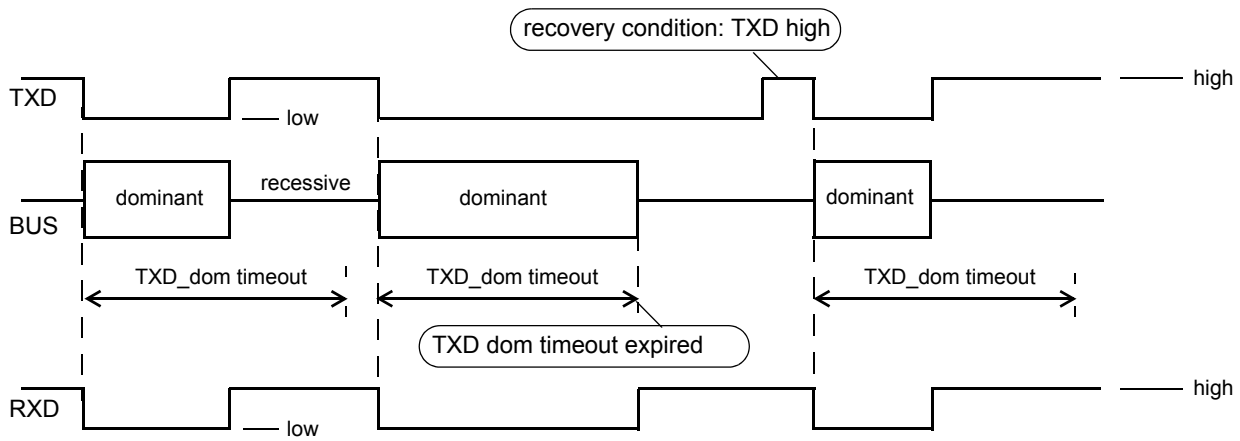

Figure 12. TXD Dominant Timeout Detection Illustration

5 Typical Applications

5.1 Application Diagrams

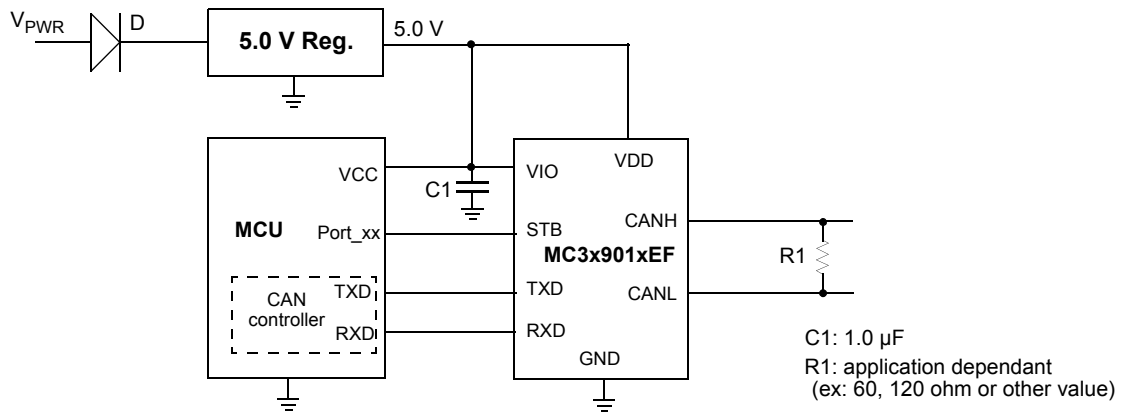

Figure 13. Single Supply Typical Application Schematic for MC3x901xEF

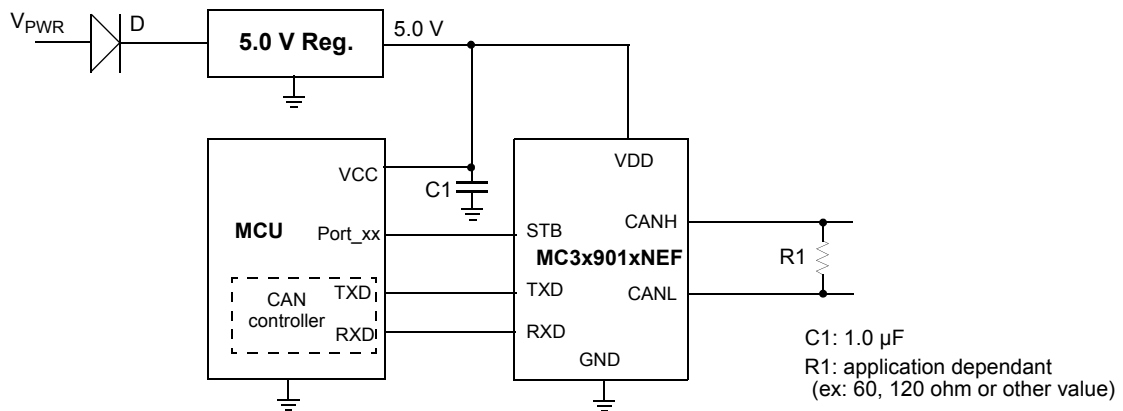

Figure 14. Single Supply Typical Application Schematic for MC3x901xNEF

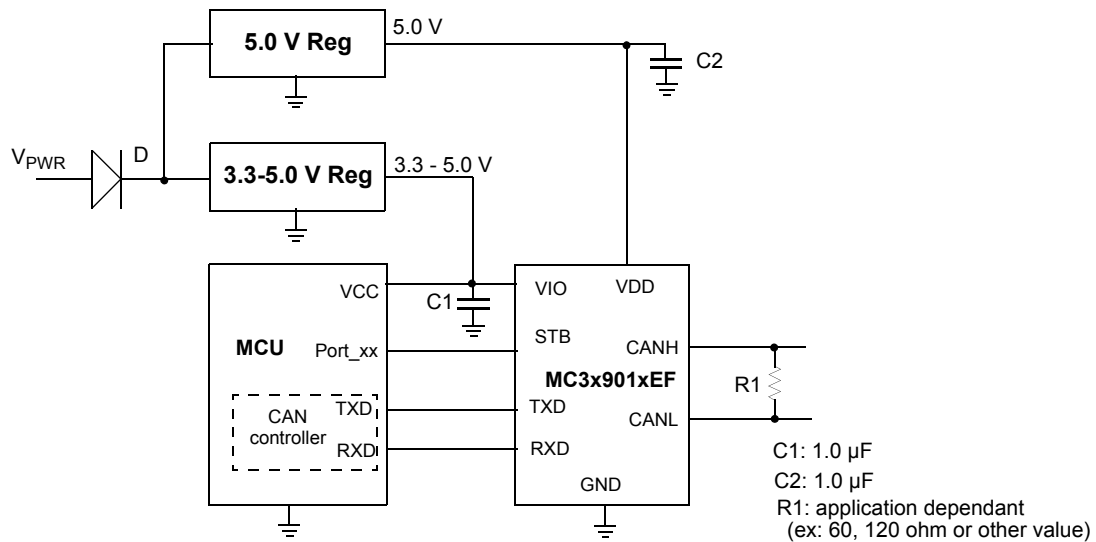

Figure 15. Dual Supply Typical Application Schematic for MC3x901xEF

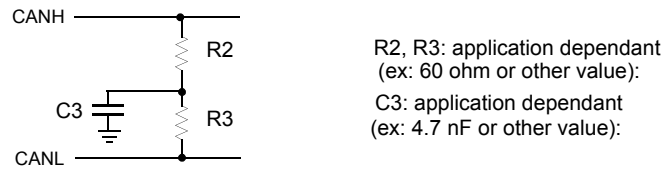

Figure 16. Example of Bus Termination Options

6 Packaging

6.1 Package Mechanical Dimensions

Package dimensions are provided in package drawings. To find the most current package outline drawing, go to www.freescale.com and perform a keyword search for the drawing's document number.

Table 10. Packaging Information

Package	Suffix	Package Outline Drawing Number
8-Pin SOICN	EF	98ASA42564B

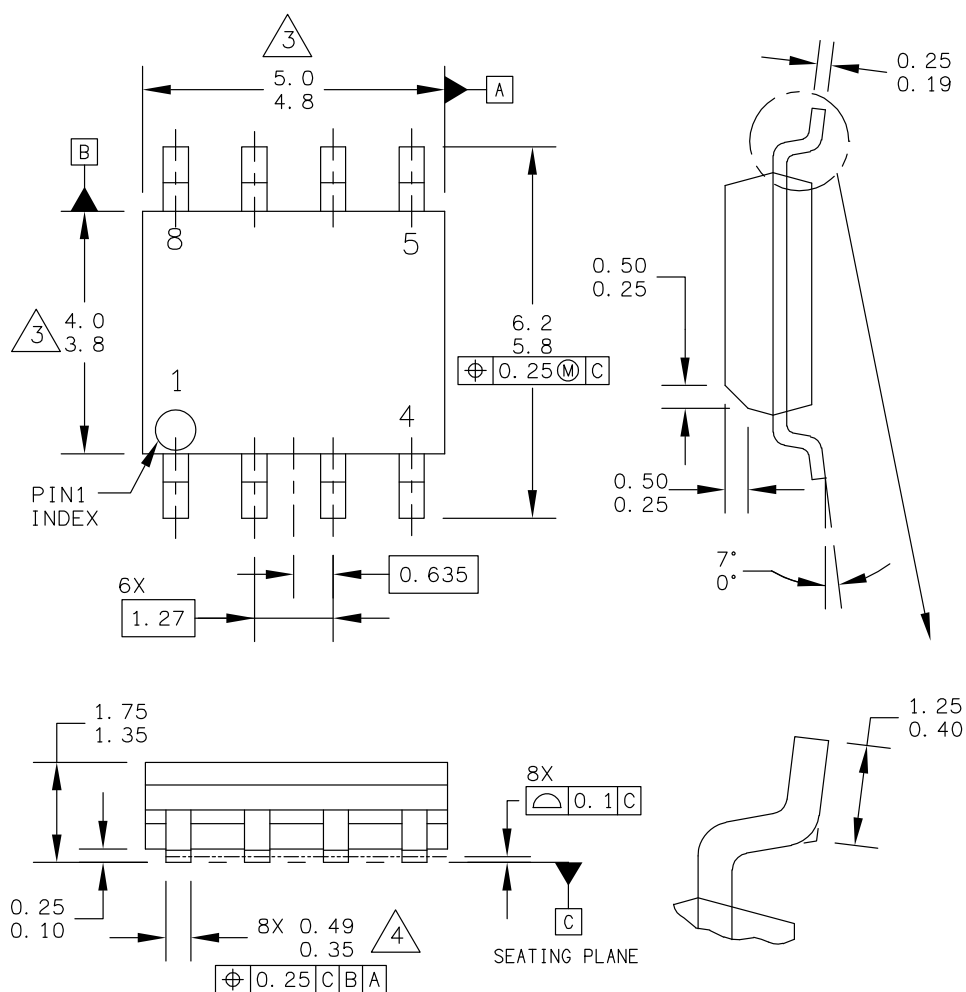

© FREESCALE SEMICONDUCTOR, INC. ALL RIGHTS RESERVED.	MECHANICAL OUTLINE	PRINT VERSION NOT TO SCALE	
TITLE: 8LD SOICN NARROW BODY	DOCUMENT NO: 98ASB42564B	REV: V	
	CASE NUMBER: 751-07	20 NOV 2007	
	STANDARD: JEDEC MS-012AA		



NOTES:

1. DIMENSIONS ARE IN MILLIMETERS.
2. DIMENSIONING AND TOLERANCING PER ASME Y14.5M-1994.
3. DIMENSION DOES NOT INCLUDE MOLD PROTRUSION. MAXIMUM MOLD PROTRUSION 0.15 PER SIDE.
4. DIMENSION DOES NOT INCLUDE DAMBAR PROTRUSION. ALLOWABLE DAMBAR PROTRUSION SHALL BE 0.127 TOTAL IN EXCESS OF THE DIMENSION AT MAXIMUM MATERIAL CONDITION.

© FREESCALE SEMICONDUCTOR, INC. ALL RIGHTS RESERVED.	MECHANICAL OUTLINE	PRINT VERSION NOT TO SCALE	
TITLE: 8LD SOIC NARROW BODY	DOCUMENT NO: 98ASB42564B	REV: V	
	CASE NUMBER: 751-07	20 NOV 2007	
	STANDARD: JEDEC MS-012AA		

7 Revision History

REVISION	DATE	DESCRIPTION OF CHANGES
1.0	12/2013	<ul style="list-style-type: none"> Initial release
2.0	4/2015	<ul style="list-style-type: none"> Changed Advance Information to Technical Data Added information for high-speed (up to 1.0 Mbit/s) Added V_{REC_SM} (CANH, CANL recessive voltage, sleep mode) to Table 7 Added V_{SYM} (Driver symmetry) to Table 7 Added I_{IN_UPWR} to Table 7
3.0	6/2015	<ul style="list-style-type: none"> Added MC33901xNEF and MC34901xNEF parts to Table 1, Orderable Parts Added additions to all figures and tables to include the variations for the new part numbers

How to Reach Us:

Home Page:
freescale.com

Web Support:
freescale.com/support

Information in this document is provided solely to enable system and software implementers to use Freescale products. There are no express or implied copyright licenses granted hereunder to design or fabricate any integrated circuits based on the information in this document.

Freescale reserves the right to make changes without further notice to any products herein. Freescale makes no warranty, representation, or guarantee regarding the suitability of its products for any particular purpose, nor does Freescale assume any liability arising out of the application or use of any product or circuit, and specifically disclaims any and all liability, including without limitation consequential or incidental damages. "Typical" parameters that may be provided in Freescale data sheets and/or specifications can and do vary in different applications, and actual performance may vary over time. All operating parameters, including "typicals," must be validated for each customer application by customer's technical experts. Freescale does not convey any license under its patent rights nor the rights of others. Freescale sells products pursuant to standard terms and conditions of sale, which can be found at the following address: freescale.com/SalesTermsandConditions.

Freescale and the Freescale logo are trademarks of Freescale Semiconductor, Inc., Reg. U.S. Pat. & Tm. Off. SMARTMOS is a trademark of Freescale Semiconductor, Inc. All other product or service names are the property of their respective owners.

© 2015 Freescale Semiconductor, Inc.

Document Number: MC33901
Rev. 3.0
6/2015