



Chipsmall Limited consists of a professional team with an average of over 10 year of expertise in the distribution of electronic components. Based in Hongkong, we have already established firm and mutual-benefit business relationships with customers from,Europe,America and south Asia,supplying obsolete and hard-to-find components to meet their specific needs.

With the principle of "Quality Parts,Customers Priority,Honest Operation,and Considerate Service",our business mainly focus on the distribution of electronic components. Line cards we deal with include Microchip,ALPS,ROHM,Xilinx,Pulse,ON,Everlight and Freescale. Main products comprise IC,Modules,Potentiometer,IC Socket,Relay,Connector.Our parts cover such applications as commercial,industrial, and automotives areas.

We are looking forward to setting up business relationship with you and hope to provide you with the best service and solution. Let us make a better world for our industry!



Contact us

Tel: +86-755-8981 8866 Fax: +86-755-8427 6832

Email & Skype: info@chipsmall.com Web: www.chipsmall.com

Address: A1208, Overseas Decoration Building, #122 Zhenhua RD., Futian, Shenzhen, China



Configurable Motor Driver IC with Power Supplies

The 34921 power IC integrates multiple motor drivers, multiple power regulators, and most other analog functions a small consumer motion-enabled product needs. The 34921's circuitry is fully protected with current limiting, short-circuit shutdown, over-temperature, over-voltage, and under-voltage detection. Supervisory functions can be read and programmed through a 8-MHz Serial Interface.

A 5.0 V dual-mode (linear or switching) voltage regulator, 3.3 V switching buck regulator, and a voltage-selectable (1.5 V, 1.8 V, 2.5 V) linear regulator provide power management. Two H-Bridges and a configurable motor driver are provided for controlling two dc motors and one unipolar stepper motor.

The highly integrated 34921 brings together sensing, communication, power management, system protection, and motor control in one device.

Features

- Two Functionally Identical Pulse-Width Modulated (PWM) DC Motor Drivers
- One Switching, One Linear, and One Dual-Mode Regulator
- Dual Mode Switching/Linear 5.0 V Regulator
- Supervisory Functions (Power-ON Reset and Error Reset Circuitry)
- 8-Channel, 8-Bit Analog-to-Digital Converter (ADC)
- Charge Pump for High-Side MOSFET Drive
- Complete Support for
- Analog Quadrature Encoder
- Pb-Free package is designated by suffix AE

34921

H-BRIDGE MOTOR DRIVER AND POWER SUPPLY

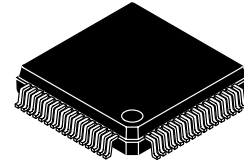

AE SUFFIX (Pb-Free)
98ARH98426A
64-LEAD LQFP-EP

ORDERING INFORMATION

Device	Temperature Range (T _A)	Package
MC34921AE/R2	0°C to 70°C	64 LQFP-EP

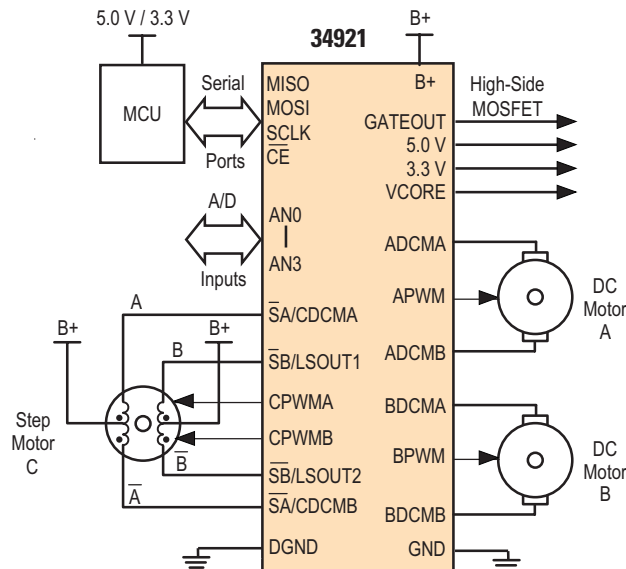

Figure 1. 34921 Simplified Application Diagram

INTERNAL BLOCK DIAGRAM

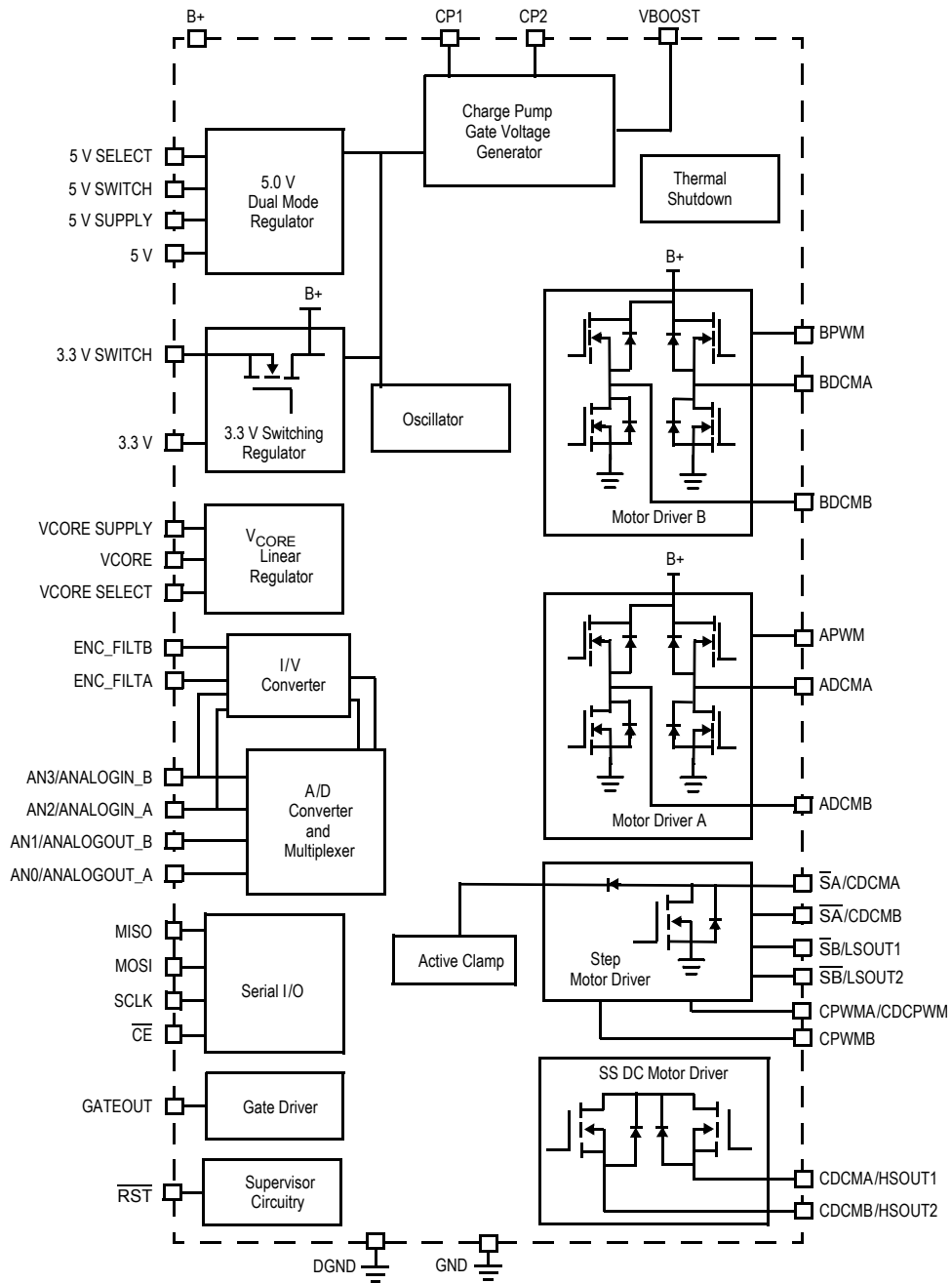

Figure 2. 34921 Simplified Internal Block Diagram

TERMINAL CONNECTIONS

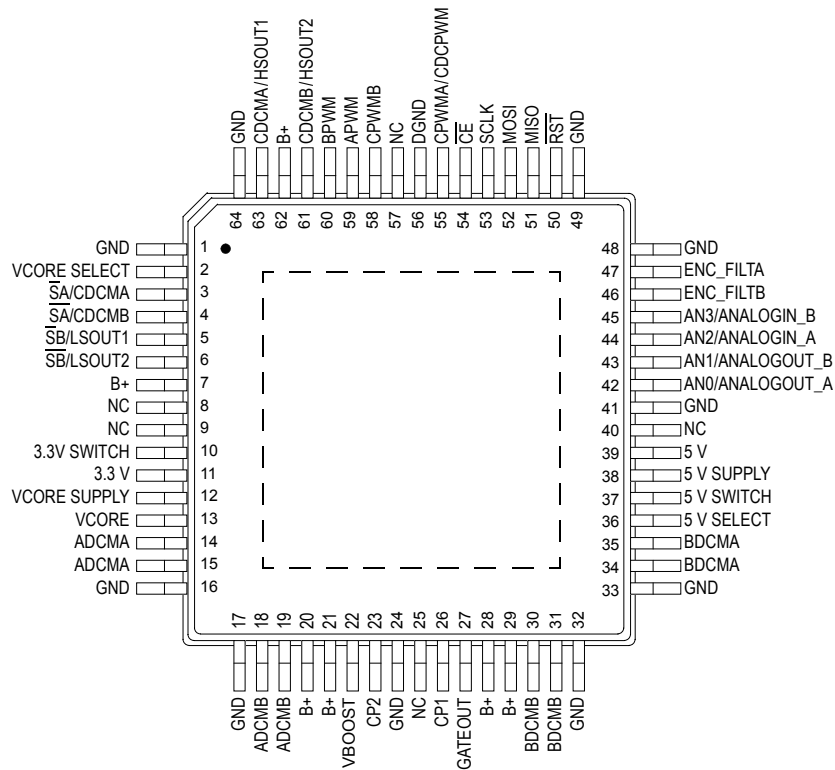

Figure 3. Terminal Function Description

Table 1. Terminal Function Description

A functional description of each terminal can be found in the Functional Terminal Description section beginning on [page 18](#)

Terminal	Terminal Name	Formal Name	Definition
1, 16, 17, 24, 32, 33, 41, 48, 49, 64	GND	Ground	Ground.
2	VCORE SELECT	Core Voltage Output Select	Core voltage regulator output voltage select.
3	$\overline{SA}/CDCMA$	Unipolar Step A/ DC Motor C Output A	Step Motor Output A or DC Motor C Output A.
4	$\overline{SA}/CDCMB$	Unipolar Step \overline{A} / DC Motor C Output B	Step Motor Output \overline{A} or DC Motor C Output B.
5	$\overline{SB}/LSOUT1$	Unipolar Step B/ Low-Side 1	Step Motor Output B or Low-Side Output 1.
6	$\overline{SB}/LSOUT2$	Unipolar Step \overline{B} / Low-Side 2	Step Motor Output \overline{B} or Low-Side Output 2.
7, 20, 21, 28, 29, 62	B+	Power Supply Input	Motor and regulator input voltage.
8, 9, 25, 40, 57	NC	No Connect	No internal connection to this terminal.

Table 1. Terminal Function Description (continued)

 A functional description of each terminal can be found in the Functional Terminal Description section beginning on [page 18](#)

Terminal	Terminal Name	Formal Name	Definition
10	3.3 V SWITCH	3.3 V Switching Regulator Switch Output	3.3 V regulator switching output.
11	3.3 V	3.3 V Regulator Feedback	Feedback terminal for 3.3 V switching regulator and internal logic supply.
12	VCORE SUPPLY	Core Voltage Regulator Input	Core regulator input supply.
13	VCORE	Core Voltage Regulator Output	Core regulator output voltage.
14, 15	ADCMA	DC Motor A Output A	DC motor driver A output A.
18, 19	ADCMB	DC Motor A Output B	DC motor driver A output B.
22	VBOOST	Boost Voltage	Boost voltage storage node.
23	CP2	Switching Capacitor 2	Charge pump capacitor connection 2.
26	CP1	Switching Capacitor 1	Charge pump capacitor connection 1.
27	GATEOUT	High-Side MOSFET Gate Driver	Gate driver for external N-channel switch.
30, 31	BDCMB	DC Motor B Output B	DC motor driver B output B.
34, 35	BDCMA	DC Motor B Output A	DC motor driver B output A.
36	5 V SELECT	5.0 V Regulator Mode Select	5.0 V regulator operating mode select.
37	5 V SWITCH	5.0 V Switching Regulator Switch Output	5.0 V switching regulator switching output.
38	5 V SUPPLY	5.0 V Regulator Input Supply	5.0 V regulator input voltage.
39	5 V	5.0 V Regulator Feedback	5.0 V regulator feedback.
42	AN0/ANALOGOUT_A	AN0/Analogout_A	A/D input 0 or analog encoder output A.
43	AN1/ANALOGOUT_B	AN1/Analogout_B	A/D input 1 or analog encoder output B.
44	AN2/ANALOGIN_A	AN2/Analogin_A	A/D input 2 or analog encoder input A.
45	AN3/ANALOGIN_B	AN3/Analogin_B	A/D input 3 or analog encoder input B.
46	ENC_FILT B	Analog Encoder Channel B Filter	I/V amplifier channel B filter.
47	ENC_FILT A	Analog Encoder Channel A Filter	I/V amplifier channel A filter.
50	$\overline{\text{RST}}$	Reset	Reset input and output.
51	MISO	Master In Slave Out	Serial data out to MCU.
52	MOSI	Master Out Slave In	Serial data in from MCU.
53	SCLK	Serial Clock	Serial data clock.

Table 1. Terminal Function Description (continued)

A functional description of each terminal can be found in the Functional Terminal Description section beginning on [page 18](#)

Terminal	Terminal Name	Formal Name	Definition
54	$\overline{\text{CE}}$	Chip Enable	Serial data strobe.
55	CPWMA/CDCPWM	Motor Driver C PWM Input A	Step motor driver Phase A PWM or DC motor driver PWM.
56	DGND	Digital Ground	Digital ground.
58	CPWMB	Motor Driver C PWM Input B	Step motor driver Phase B PWM.
59	APWM	Motor Driver A PWM Input	PWM input for DC motor driver A.
60	BPWM	Motor Driver B PWM Input	PWM input for DC motor driver B.
61	CDCMB/HSOUT2	Motor Driver C DC Motor Output or High-Side Output 2	Step motor driver C output or high-side output 2.
63	CDCMA/HSOUT1	Motor Driver C DC Motor Output or High-Side Output 1	Step motor driver C output or high-side output 1.

MAXIMUM RATINGS

Table 2. Maximum Ratings

All voltages are with respect to ground unless otherwise noted. Exceeding these ratings may cause a malfunction or permanent damage to the device.

Rating	Symbol	Max	Unit
ELECTRICAL Ratings			
Input Power Supply Voltage $I_{B+} = 0.0 \text{ A}$	B+	-0.3 to 38	V
Logic Input Voltage	V_{IN}	-0.3 to $V_{5.0} + 0.3$	V
Boost Supply Voltage	V_{BOOST}	$B^+ + 15$	V
Input Power Supply Ripple Voltage Ripple Voltage Measured at < 20 MHz	$V_{RIPPLEB}$	400	mV _{PP}
Motor Drivers A & B Maximum Output Voltage	V_{OUTMAX}	40	V
5.0 V Linear Regulator Maximum Output Voltage Startup	$V_{5.0}$	5.4	V
5.0 V Switching Regulator Maximum Output Voltage Startup	$V_{5.0}$	5.4	V
3.3 V Switching Regulator Maximum Output Voltage Startup	$V_{3.3}$	3.6	V
VCORE Linear Regulator Maximum Output Voltage $I_{CORE} = 0.0 \text{ A}$	V_{CORE}	$V_{CORE_NOM} + 10\%$	V
Motor Drivers A, B, and C (Motor Driver C Configured as Step Motor Driver) ⁽¹⁾ Motor Driver A Sink or Source Current Motor Driver B Sink or Source Current Motor Driver C Sink or Source Current	$I_{PWM(A)}$ $I_{PWM(B)}$ $I_{PWM(C)}$	± 4.5 ± 4.5 ± 1.5	A
Motor Driver C in Step Mode Step Motor Output Current Output x or \bar{x} On	I_{STEP}	2.0	A
Motor Driver C in Step Mode Standoff Voltage Output Off, $I_{DSS} = 10 \text{ mA}$	V_{BVDS}	60	V
ESD Voltage ⁽²⁾ Non-Operating, Unbiased, Human Body Model Machine Model Charge Device Model	V_{ESD}	± 2000 ± 200 ± 250	V

Notes

- B+ = 34 V, Motor Stalled and Saturated
- ESD testing is performed in accordance with the Human Body Model ($C_{ZAP} = 100 \text{ pF}$, $R_{ZAP} = 1500 \text{ }\Omega$), the Machine Model ($C_{ZAP} = 200 \text{ pF}$, $R_{ZAP} = 0 \text{ }\Omega$), and the Charge Device Model.

Table 2. Maximum Ratings(continued)

All voltages are with respect to ground unless otherwise noted. Exceeding these ratings may cause a malfunction or permanent damage to the device.

Rating	Symbol	Max	Unit
THERMAL RATINGS			
Operating Temperature Ambient Junction	T_A T_J	0.0 to 70 150	°C
Storage Temperature	T_{STG}	-55 to 150	°C
Thermal Resistance Junction to Ambient ⁽³⁾ Junction to Board ⁽⁴⁾ Junction to Case	$R_{\theta JA}$ $R_{\theta JB}$ $R_{\theta JC}$	40 14 <1.0	°C/W
Peak Package Reflow Temperature During Solder Mounting ⁽⁵⁾	T_{SOLDER}	245	°C
THERMAL RESISTANCE AND PACKAGE DISSIPATION RATINGS			
Power Dissipation ($T_A = 25^\circ\text{C}$) ⁽⁶⁾	P_D	2.0	W

Notes

- 1s PCB test board JESD51-2 and SEMI G38-87.
- Thermal resistance between the die and the printed circuit board per JEDEC JESD51-8. Board temperature is measured at the package center lead foot. 2s2p test board, exposed pad soldered to PCB.
- Terminal soldering temperature limit is for 10 seconds maximum duration. Not designed for immersion soldering. Exceeding these limits may cause malfunction or permanent damage to the device.
- Maximum power dissipation at indicated ambient temperature in free air with no heatsink used.

STATIC ELECTRICAL CHARACTERISTICS

Table 3. Static Electrical Characteristics

Characteristics noted under conditions $16\text{ V} \leq B+ \leq 34\text{ V}$, $0^\circ\text{C} \leq T_A \leq 70^\circ\text{C}$, and $0^\circ\text{C} \leq T_J \leq 100^\circ\text{C}$ unless otherwise noted. Typical values noted reflect the approximate parameter means at $T_A = 25^\circ\text{C}$ under nominal conditions unless otherwise noted.

Characteristic	Symbol	Min	Typ	Max	Unit
Serial Interfaces (MISO, MOSI, SCLK, $\overline{\text{CE}}$)					
Input Low Voltage from MCU $V_{5.0} = 5.0\text{ V}$, $V_{3.3} = 3.3\text{ V}$, $I_{IN} \leq 200\ \mu\text{A}$, V_{IN} Falling	V_{IL}	1.1	1.35	2.2	V
Input High Voltage $V_{5.0} = 5.0\text{ V}$, $V_{3.3} = 3.3\text{ V}$, $I_{IN} \leq 200\ \mu\text{A}$, V_{IN} Rising	V_{IH}	1.1	2.00	2.2	V
Input Hysteresis $V_{5.0} = 5.0\text{ V}$, $V_{3.3} = 3.3\text{ V}$	V_{HYS}	0.4	0.6	1.5	V
Output High-Level, MISO ($V_{5.0} = 5.0\text{ V}$, $V_{3.3} = 3.3\text{ V}$) $I_{OUT} = 150\ \mu\text{A}$ $I_{OUT} = 20\ \mu\text{A}$	$V_{OH}(\text{MISO})$	2.4 $V_{3.3}-0.1$	$V_{3.3}-25\text{ mV}$ $V_{3.3}-10\text{ mV}$	$V_{3.3}$ $V_{3.3}$	V
Output Low-Level, MISO ($V_{5.0} = 5.0\text{ V}$, $V_{3.3} = 3.3\text{ V}$) $I_{OUT} \leq 20\ \mu\text{A}$ $I_{OUT} \leq 150\ \mu\text{A}$	$V_{OL}(\text{MISO})$	0.0 0.0	10 25	100 400	mV
Input Pulldown Current $V_{5.0} = 5.0\text{ V}$, $V_{3.3} = 3.3\text{ V}$, $V_{IN} = 5.0\text{ V}$, Includes $\overline{\text{RST}}$	$I_{PULLDOWN}$	50	120	175	μA
MISO High-Impedance Current MISO = 3.3 V or GND	I_{HI-Z}	-100	0.1	100	μA

5.0 V Linear Regulator

Logic Supply Voltage $I_{V_{5.0}} = 10\text{ mA to } 50\text{ mA}$, $16\text{ V} \leq B+ \leq 20\text{ V}$, $R_{EXT} = 140\ \Omega$	$V_{5.0}$	4.8	5.0	5.2	V
Load Regulation $I_{LOAD} = 10\text{ mA to } 50\text{ mA}$	V_{ILOAD}	–	–	± 100	mV
Current Limit Threshold $R_{EXT} = 0\ \Omega$	I_{LIMIT}	75	135	600	mA
$V_{5.0}$ to Turn On/Off $V_{3.3}$ Regulator ⁽⁷⁾	$V_{5_3.3t}$	–	2.2	–	V
Hysteresis for $V_{5_3.3t}$ ⁽⁷⁾	$V_{5_3.3t_hys}$	–	175	–	mV

Notes

7. See [Figure 10. Power-Up Sequencing](#), page 22.

Table 3. Static Electrical Characteristics (continued)

Characteristics noted under conditions $16\text{ V} \leq B+ \leq 34\text{ V}$, $0^\circ\text{C} \leq T_A \leq 70^\circ\text{C}$, and $0^\circ\text{C} \leq T_J \leq 100^\circ\text{C}$ unless otherwise noted. Typical values noted reflect the approximate parameter means at $T_A = 25^\circ\text{C}$ under nominal conditions unless otherwise noted.

Characteristic	Symbol	Min	Typ	Max	Unit
----------------	--------	-----	-----	-----	------

5.0 V Switching Regulator

Vreg Threshold	$V_{5.0}$	4.8	5.0	5.2	V
Cycle-by-Cycle Current Limit Threshold $V_{5.0} = 2.0\text{ V to Max}$ $V_{5.0} \leq 1.0\text{ V}$	I_{LIMIT}	0.75 –	1.2 1.0	2.25 –	A
$V_{5.0}$ to Turn On/Off $V_{3.3}$ Regulator ⁽⁸⁾	$V_{5_3.3t}$	–	2.2	–	V
Hysteresis for $V_{5_3.3t}$ ⁽⁸⁾	$V_{5_3.3t_hys}$	–	175	–	mV

3.3 V Switching Regulator

Vreg Threshold	$V_{3.3}$	3.15	3.28	3.45	V
Cycle-by-Cycle Current Limit Threshold $V_{3.3} = 2.0\text{ V to Max}$ $V_{3.3} \leq 1.0\text{ V}$	I_{LIMIT}	2.75 –	3.6 3.5	5.5 –	A

VCORE 3.3V Linear Regulator

Voltage Tolerance $I_{CORE} = 0.02\text{ A to }0.3\text{ A}$, $V_{NOM} = 2.5\text{ V}$ $I_{CORE} = 0.02\text{ A to }0.3\text{ A}$, $V_{NOM} = 1.8\text{ V}$ $I_{CORE} = 0.02\text{ A to }0.3\text{ A}$, $V_{NOM} = 1.5\text{ V}$	V_{CORE_TOL}	2.35 1.675 1.4	2.49 1.78 1.49	2.66 1.925 1.6	V
Load Regulation $I_{LOAD} = 20\text{ mA to }300\text{ mA}$	V_{ILOAD}	–	± 10	± 100	mV
Current Limit Threshold	I_{LIMIT}	400	750	1200	mA

Motor Drivers in DC Mode

Motor Driver A High- or Low-Side Switch Voltage Drop $I_{PWM} = 1.7\text{ A}$, GND or B+ to Output	$V_{DROP(A)}$	–	.65	1.5	V
Motor Driver A Output Current Limit	$I_{LIMIT(A)}$	3.6	4.9	7.2	A
Motor Driver B High- or Low-Side Switch Voltage Drop $I_{PWM} = 2.0\text{ A}$, GND or B+ to Output	$V_{DROP(B)}$	–	.70	1.4	V
Motor Driver B Output Current Limit	$I_{LIMIT(B)}$	2.8	4.9	7.2	A
Motor Driver C High- or Low-Side Switch Voltage Drop $I_{PWM} = 0.375\text{ A}$, GND or B+ to Output	$V_{DROP(C)}$	–	.75	1.5	V
Motor Driver C Current Limit—Top Side	$I_{LIMIT1(C)}$	0.75	1.2	1.5	A
Motor Driver C Current Limit—Bottom Side	$I_{LIMIT2(C)}$	1.0	1.65	2.0	A

Notes

8. See [Figure 10, Power-Up Sequencing](#), page 22.

Table 3. Static Electrical Characteristics (continued)

Characteristics noted under conditions $16\text{ V} \leq B+ \leq 34\text{ V}$, $0^\circ\text{C} \leq T_A \leq 70^\circ\text{C}$, and $0^\circ\text{C} \leq T_J \leq 100^\circ\text{C}$ unless otherwise noted. Typical values noted reflect the approximate parameter means at $T_A = 25^\circ\text{C}$ under nominal conditions unless otherwise noted.

Characteristic	Symbol	Min	Typ	Max	Unit
----------------	--------	-----	-----	-----	------

Motor Drivers in DC Mode (cont)

Output MOSFET Leakage Current $V_{GS} = 0.0\text{ V}$, $V_O = 0.0\text{ V}$ or 20 V	I_{DSS}	–	0.1	± 40	μA
Current Limit Maximum Duty Cycle ⁽⁹⁾	IDC_{LIMIT}	1.0	2.0	4.0	%
Current Limit Pulse Width ⁽⁹⁾	$I_{LIMITPW}$	0.5	1.5	6.0	μs

Motor Driver C in Step Mode

Switch Voltage Drop, Output to Ground $I_{STEP} = 0.375\text{ A}$, GND to Output	V_{SDROP}	–	–	1.5	V
Step Motor Current Limit $B+ = 20\text{ V}$	$I_{STEP(LIMIT)}$	1.0	–	2.0	A
Voltage at Which Internal Clamp Activates $I_{DSS} = 1.0\text{ mA}$, $B+ = 20\text{ V}$	V_{CLAMP}	44	51	59	V
Tested Maximum High-Voltage Leakage Current $V_S = V_{CLAMP} + 4.0$	$I_{BREAKDOWN}$	–	0.5	40	μA
Any Step Driver Output Leakage Current to Ground $B+ = 20\text{ V}$, $V_S = 20\text{ V}$	$I_{LEAKAGE}$	–	0.1	40	μA
Current Limit Maximum Duty Cycle	td_{ILIMIT}	5.0	11	15	%
Current Limit Pulse Width	$I_{LIMITPW}$	5	10	20	μs

 V_b Charge Pump

Boost Voltage $I_B = 0.5\text{ mA}$	V_b	$B^+ + 10$	$B^+ + 11.5$	$B^+ + 15$	V
--	-------	------------	--------------	------------	---

External N-FET Gate Drive Output

GATEOUT High Output $I_{OH} = 4.0\text{ mA}$ $I_{OH} = 200\text{ }\mu\text{A}$	V_{OH2}	$V_b - 6.0$ $V_b - 0.3$	$V_b - 2.5$ $V_b - .1$	V_b V_b	V
GATEOUT Low Output $I_{OL} = -200\text{ }\mu\text{A}$	V_{OL}	–	0.1	0.3	V

Notes

9. Motor driver A, B, C Top Side only. For C Bottom Side, see Motor Driver C in Step Mode: Current Limit Maximum Duty Cycle and Current Limit Pulse Width

Table 3. Static Electrical Characteristics (continued)

Characteristics noted under conditions $16\text{ V} \leq B+ \leq 34\text{ V}$, $0^\circ\text{C} \leq T_A \leq 70^\circ\text{C}$, and $0^\circ\text{C} \leq T_J \leq 100^\circ\text{C}$ unless otherwise noted. Typical values noted reflect the approximate parameter means at $T_A = 25^\circ\text{C}$ under nominal conditions unless otherwise noted.

Characteristic	Symbol	Min	Typ	Max	Unit
Supervisor Circuitry					
Minimum Function B+ for Charge Pump, Oscillator Up Reset/Fault Registers Valid ⁽¹⁰⁾	B+	9.0	–	–	V
Minimum Function V _{5.0} for $\overline{\text{RST}}$ Operational $\overline{\text{RST}} V_{\text{OL}} \leq 0.05\text{ V @ } 1.0\text{ mA}$ ⁽¹⁰⁾	V _{5.0} $\overline{\text{RST}}$	2.0	–	–	V
Minimum Function V _{3.3} for $\overline{\text{RST}}$ Operational $\overline{\text{RST}} V_{\text{OL}} \leq 0.05\text{ V @ } 1.0\text{ mA}$ ⁽¹⁰⁾	V _{3.3} $\overline{\text{RST}}$	2.0	–	–	V
$\overline{\text{RST}}$ Low Voltage ⁽¹¹⁾ $I_{\overline{\text{RST}}} \leq 5.0\text{ mA}$	V _{OL}	–	0.1	0.25	V
$\overline{\text{RST}}$ V _{5.0} Threshold V _{5.0} Rising V _{5.0} Falling	V _{5.0t+} V _{5.0t-}	– 4.5	4.65 4.6	4.75 4.70	V
$\overline{\text{RST}}$ Hysteresis for V _{5.0}	V _{HYSV5.0}	10	50	–	mV
$\overline{\text{RST}}$ V _{3.3} Threshold V _{3.3} Rising V _{3.3} Falling	V _{3.3t+} V _{3.3t-}	– 2.8	2.9 2.9	3.15 3.0	V
$\overline{\text{RST}}$ Hysteresis for V _{3.3}	V _{HYS_3.3}	10	15	–	mV
$\overline{\text{RST}}$ V _{CORE} Threshold V _{CORE} Falling	V _{CORE}	85	86	90	% V _{CORE_NOM}
$\overline{\text{RST}}$ Hysteresis for V _{CORE}	V _{HYS CORE}	–	10	–	mV
Overtemperature Junction Temperature ⁽¹²⁾ T _J Rising	T _{J(OVER)}	140	–	–	°C
Overtemperature Hysteresis ⁽¹²⁾ T _J Falling	T _{J(HYS)}	10	–	30	°C
Thermal Warning ⁽¹²⁾	T _W	T _J -30	–	T _J -20	°C
B+ Undervoltage Threshold to Assert $\overline{\text{RST}}$ V _{5.0} = +5.0 V, B+ Falling	B _{+(FAULT)}	12	12.75	13.5	V
B+ Undervoltage Threshold Hysteresis ⁽¹³⁾	B _{+(FAULT)(HYS)}	1.0	1.5	2.0	V
Minimum B+ Necessary to Clear B+ Fault V _{5.0} = +5.0 V, B+ Rising	B _{+(RECOVERY)}	–	–	15.25	V

Notes

- If any of these conditions for this not is true, then $\overline{\text{RST}}$ is activated until all operating conditions are met.
- The $\overline{\text{RST}}$ terminal uses an external pull-up, which may be to 5.0 V or 3.3 V.
- Guaranteed by design.
- Alternately, the minimum B+ fault threshold voltage must not be lower than 12 V, and the B+ fault clear voltage must not be higher than 15.25 V. The hysteresis may be greater than 2.0 V if this requirement is met.

Table 3. Static Electrical Characteristics (continued)

Characteristics noted under conditions $16\text{ V} \leq B+ \leq 34\text{ V}$, $0^\circ\text{C} \leq T_A \leq 70^\circ\text{C}$, and $0^\circ\text{C} \leq T_J \leq 100^\circ\text{C}$ unless otherwise noted. Typical values noted reflect the approximate parameter means at $T_A = 25^\circ\text{C}$ under nominal conditions unless otherwise noted.

Characteristic	Symbol	Min	Typ	Max	Unit
----------------	--------	-----	-----	-----	------

Analog Encoder Interface Current-to-Voltage Conversion Stage

Minimum Offset Current	$I_{\text{OFFSET_MIN}}$	-6.0	-8.0	-10	μA
Midpoint Offset Current	$I_{\text{OFFSET_MID}}$	-0.5	0.0	0.5	μA
Maximum Offset Current	$I_{\text{OFFSET_MAX}}$	6.0	8.0	10	μA
Offset Step Size (1 LSB)	I_{OFFSTEP}	0.25	0.5	0.75	μA

Analog-to-Digital Converter

Resolution, No Missing Codes	ADC	–	–	8.0	Bits
Measurement Range for Correct Conversion	IMR	0.0	–	5.0	V
Linearity Error ⁽¹⁶⁾ Over Input Voltage Range of 4% to 96% Ideal Measurement Range (IMR) max. Over Time and Temperature ^{(14), (15)} $V_{\text{IN}} = -0.5$ to 5.5 V ⁽¹⁷⁾	I_{NL}	–	0.4	± 1.0 LSB	–
Input Leakage Current (ANx) $V_{5.0} = 5.0\text{ V}$, $T_J = 25^\circ\text{C}$, $V_{\text{ANx}} = 5.0\text{ V}$, ANALOG_TEST MODE = 0, Channel Not Selected	I_{LEAKAGE}	–	0.1	10	μA

Notes

14. Errors include effects of multiplexer and sample and hold circuitry, including droop.
15. The Linearity Error is the worst case error caused by the differential and integral nonlinearity.
16. An LSB (least significant bit) is defined as follows:

$$\text{LSB} = \frac{\text{IMR}}{2^{\#\text{BITS}-1}} \text{ Volts}$$

Where:

- IMR is the Ideal Measurement Range.
- #BITS is the resolution of the ADC.

17. The ADC will read full scale at $V_{\text{IN}} = 5.0\text{ V}$. If V_{IN} on one input exceeds this value, the value of other inputs may become unreadable.

Table 3. Static Electrical Characteristics (continued)

Characteristics noted under conditions $16\text{ V} \leq B+ \leq 34\text{ V}$, $0^\circ\text{C} \leq T_A \leq 70^\circ\text{C}$, and $0^\circ\text{C} \leq T_J \leq 100^\circ\text{C}$ unless otherwise noted. Typical values noted reflect the approximate parameter means at $T_A = 25^\circ\text{C}$ under nominal conditions unless otherwise noted.

Characteristic	Symbol	Min	Typ	Max	Unit
Analog-to-Digital Converter (cont)					
Zero Error (18), (19)	E_Z	–	± 1.0	± 8.0	LSB ⁽²⁰⁾
Zero Error Drift Over Time and Temperature (18)	E_{ZD}	–	± 4.0	–	LSB
Full Scale Error (18), (19), (21)	E_{FS}	–	± 2.0	± 8.0	LSB

Notes

- Errors include effects of multiplexer and sample and hold circuitry, including droop.
- The Zero Error is defined as the number of LSB values away from the ideal value of 1/2 LSB that the ADC output count will transition from 0 to 1 when the input is swept through the range of interest. The transition must occur within the specified range.

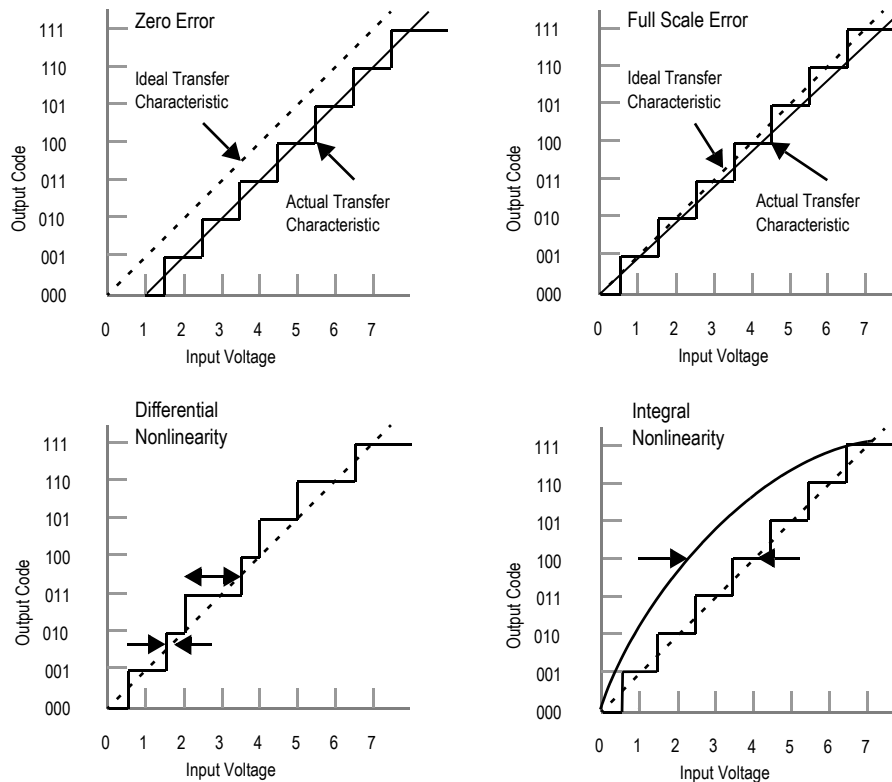

- An LSB is defined as follows:

$$\text{LSB} = \frac{\text{IMR}}{2^{\#\text{BITS}-1}} \text{ Volts}$$

Where:

- IMR is the Ideal Measurement Range.
- #BITS is the resolution of the ADC.

- The Full Scale Error is defined as the number of LSB values away from the ideal value of -1/2 LSB from Full Scale that the ADC output count actually transitions from -1 LSB count to Full Scale count when the input voltage is swept through the voltage range of interest. The transition must occur within the specified range.

DYNAMIC ELECTRICAL CHARACTERISTICS
Table 4. Dynamic Electrical Characteristics

Characteristics noted under conditions $16\text{ V} \leq B+ \leq 34\text{ V}$, $0^\circ\text{C} \leq T_A \leq 70^\circ\text{C}$, and $0^\circ\text{C} \leq T_J \leq 100^\circ\text{C}$ unless otherwise noted. Typical values noted reflect the approximate parameter means at $T_A = 25^\circ\text{C}$ under nominal conditions unless otherwise noted.

Characteristic	Symbol	Min	Typ	Max	Unit
----------------	--------	-----	-----	-----	------

Serial Interface Timing⁽²²⁾

Setup Time for $\overline{\text{CE}}$ to rising edge of SCLK ($C_L = 50\text{ pF}$)	$t_{\text{setup}(\overline{\text{CE}})}$	15	–	–	ns
Hold Time for $\overline{\text{CE}}$ after rising edge of SCLK ($C_L = 50\text{ pF}$)	$t_{\text{hold}(\overline{\text{CE}})}$	15	–	–	ns
Setup Time for MOSI to rising edge of SCLK ($C_L = 50\text{ pF}$)	$t_{\text{setup}(\text{MOSI})}$	15	–	–	ns
Hold Time for MOSI after rising edge of SCLK ($C_L = 50\text{ pF}$)	$t_{\text{hold}(\text{MOSI})}$	15	–	–	ns
Delay for MISO valid after rising edge of SCLK ($C_L = 50\text{ pF}$)	$t_{\text{delay}(\text{MISO})}$	–	35	55	ns
Period for SCLK ($C_L = 50\text{ pF}$)	$t_{\text{period}(\text{SCLK})}$	125	–	750	ns
Duty Cycle of SCLK	$t_{\text{duty}(\text{SCLK})}$	45	–	55	%

5.0 V Switching Regulator

Switching Rise and Fall Time Load Resistance = $100\ \Omega$, $B+ = 18\text{ V}$	t_r, t_f	10	30	50	ns
--	------------	----	----	----	----

3.3 V Switching Regulator

Switching Rise and Fall Time Load Resistance = $100\ \Omega$, $B+ = 18\text{ V}$	t_r, t_f	10	16	50	ns
--	------------	----	----	----	----

Motor Drivers

Motor Drivers A and B Output Waveform Rise Time $R = 7.0\ \Omega$, $V_{\text{DCX}} = (5.0\text{ V})$ to $(0.90 \times B+)$, $B+ = 18\text{ V}$	t_r	100	175	300	ns
Motor Driver C Output Waveform Rise Time $R = 25\ \Omega$, $V_{\text{DCX}} = (5.0\text{ V})$ to $(0.90 \times B+)$, $B+ = 18\text{ V}$	t_r	100	175	300	ns
Output Waveform Fall Time $V_{\text{DCX}} = (0.90 \times B+)$ to 5.0 V , $R = 7.0\ \Omega$, $B+ = 18\text{ V}$	t_f	100	–	300	ns
Crossover Dead Time ⁽²³⁾	t_{dead}	15	600	2000	ns

Motor Driver C in Step Mode

Output Rise Time $V_{\text{XPHASE}} = 5.0\text{ V}$ to $0.90 \times B+$, $R_w = 20\ \Omega$, $B+ = 18\text{ V}$	t_r	100	175	350	ns
Output Fall Time $V_{\text{XPHASE}} = 0.90 \times B+$ to 5.0 V , $R_w = 20\ \Omega$, $B+ = 18\text{ V}$	t_f	100	155	350	ns
Delay from Phase Turn-Off to Counterphase Turn-On $R_w = 20\ \Omega$, $0.90 \times B+$ Rising to $0.90 \times B+$ Falling, $B+ = 18\text{ V}$ Falling	$t_{\text{delay}}(\text{C})$	0.0	300	400	ns

Notes

22. See [Figure 4, Serial Interface Timing](#), page 16.
23. This parameter is guaranteed by design but not production tested.

Table 4. Dynamic Electrical Characteristics (continued)

Characteristics noted under conditions $16\text{ V} \leq B+ \leq 34\text{ V}$, $0^\circ\text{C} \leq T_A \leq 70^\circ\text{C}$, and $0^\circ\text{C} \leq T_J \leq 100^\circ\text{C}$ unless otherwise noted. Typical values noted reflect the approximate parameter means at $T_A = 25^\circ\text{C}$ under nominal conditions unless otherwise noted.

Characteristic	Symbol	Min	Typ	Max	Unit
----------------	--------	-----	-----	-----	------

Supervisor Circuitry

$\overline{\text{RST}}$ Delay $V_{5.0} = \geq +4.9\text{ V}$ ⁽²⁴⁾	$t_{\text{delay}}(\overline{\text{RST}})$	128	–	128	t_{SCLK}
$\overline{\text{RST}}$ Filter Time $V_{5.0} = 5.0\text{ V}$	t_{filter}	–	3.25	–	μs
$\overline{\text{RST}}$ Fall Time $V_{5.0} = 5.0\text{ V}$, $C_L = 100\text{ pF}$, $I_{\text{PULLUP}} = 0.75\text{ mA}$ (external), 90% to 10% of $V_{5.0}$	t_f	–	7.0	20	ns
External Input Low to $\overline{\text{RST}}$ Pulled Low $V_{5.0} = 5.0\text{ V}$ ⁽²⁵⁾	t_{spl}	–	26	60	ns

Analog Encoder Interface Variable Gain Stage

Adjustable Gain (Ideal) Settings $S = 0$ to 15, Default 0 Settings $S = 16$ to 31, Default 0	G (Ideal)	$(1.0 + 0.1 * S)$ $(1.0 + 0.1 * [S - 16]) / 0.375$			
Gain Setting = 0 Setting = 31	G	0.8 6.0	1.0 6.6	1.2 7.2	V/V
Gain Step Factor Tolerance Gain Step Size $G_s/G(s-1)$ $S = 1$ to 31	GSF	1.01	1.02	1.2	V/V

Analog Encoder Interface Digital Signal Conversion Stage

Operating Frequency	$f_{\text{OP(MAX)}}$	0	–	15	kHz
Comparator Filter Time ⁽²⁴⁾ Filter Configuration Bit Set to 0 Filter Configuration Bit Set to 1	t_{filter}	3.0 6.0	– –	4.0 7.0	SCLK Cycles

ADC

Sample and Hold Acquisition Time A/D Speed Bit = 0 A/D Speed Bit = 1	t_{sh}	15 31	– –	16 32	t_{SCLK}
Conversion Time (Return Word Clocked Out Immediately Following t_c) A/D Speed Bit = 0 A/D Speed Bit = 1	t_c	– –	– –	48 96	t_{SCLK}

Master Oscillator

Operating Frequency $B+ \geq 12\text{ V}$	f_{OP}	150	200	250	kHz
--	-----------------	-----	-----	-----	-----

Notes

24. Guaranteed by design.
25. See [Figure 6, RST Timing](#), page 17.

TIMING DIAGRAMS

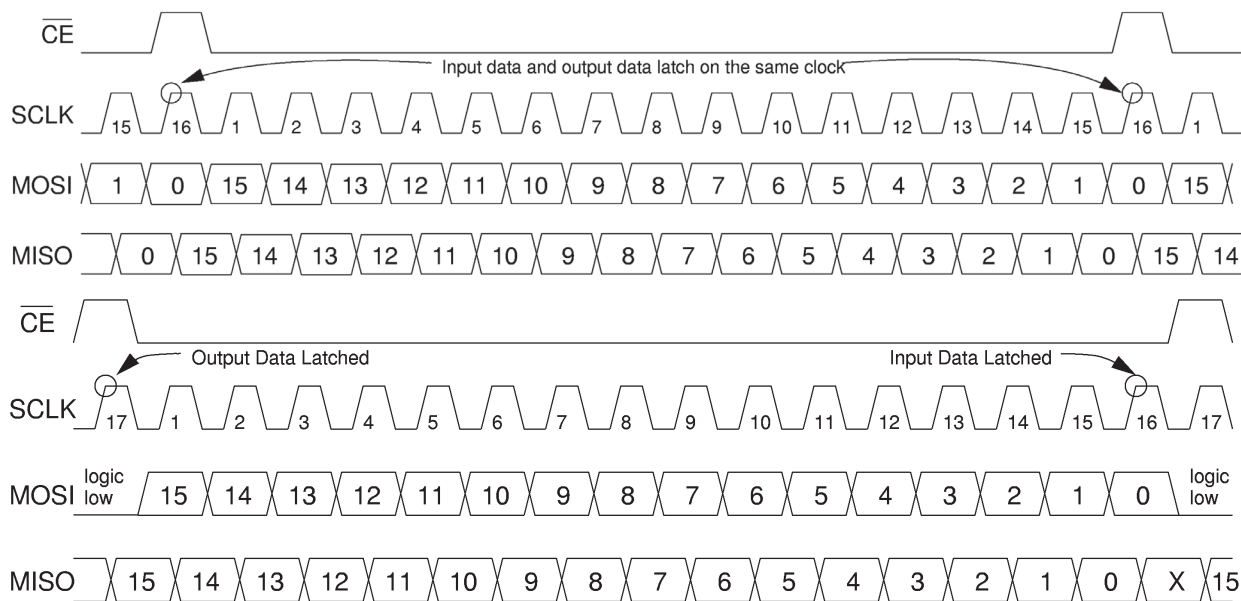

Figure 4. Serial Interface Timing

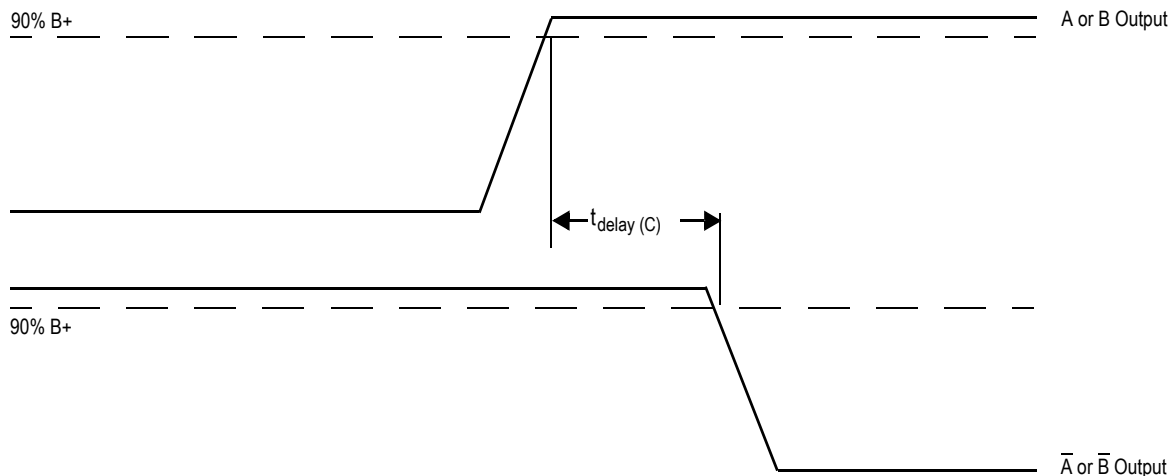

Figure 5. Step Motor Crossover Delay Timing

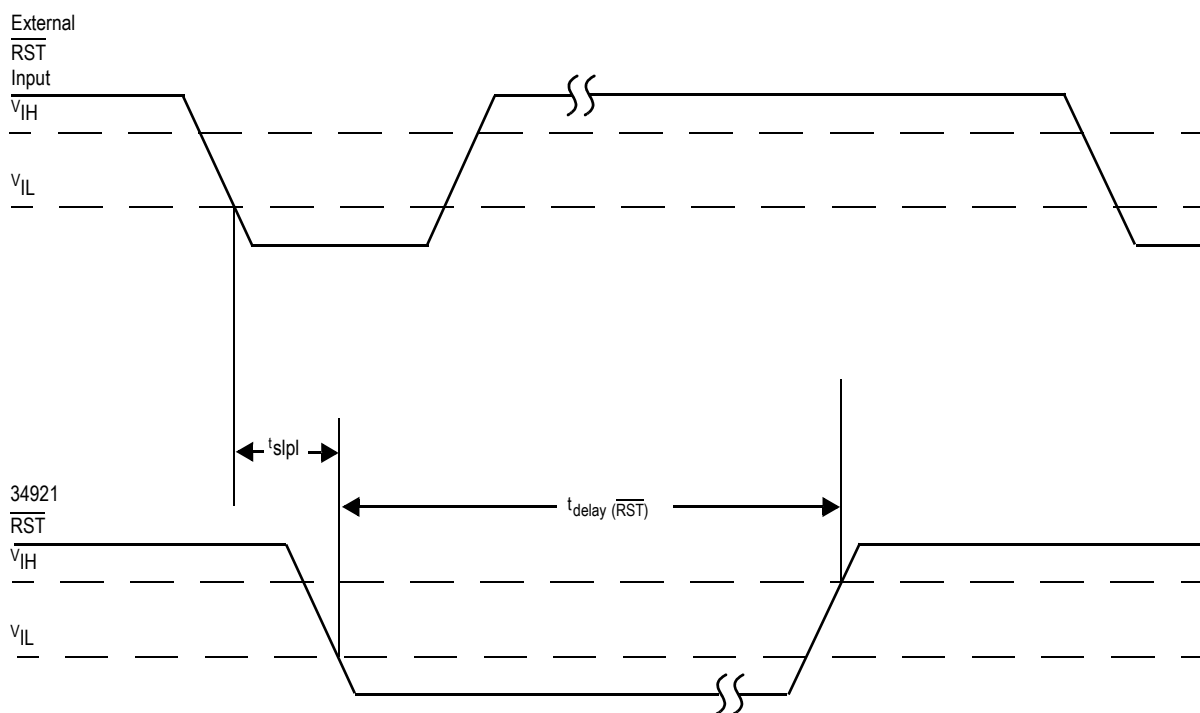

Figure 6. $\overline{\text{RST}}$ Timing

FUNCTIONAL DESCRIPTION

INTRODUCTION

The serial interface of the MC34921 is a three input, one output interface similar to a Serial Peripheral Interface (SPI) port in general form, but different in specific clocking requirements due to the fact that an A/D converter cannot reliably run without a continuous clock. The 34921 serial interface communicates to a microcontroller unit (MCU) at up to 16 MHz. The serial signals are SCLK, \overline{CE} , MOSI, and MISO. The SCLK signal pin requires a free-running clock (up to 16 MHz) which is provided by the MCU. This signal is required to ensure proper operation of both the ADC and the reset timer circuitry. The serial data transfers between the

MCU and the 34921 via the MOSI and MISO terminals. The serial data from the MCU is handled in the MC34921 via two input registers -- the NORMAL input register contains bits controlling the motor drivers as well as the A/D converter, and the CONFIG register contains bits relating to the general configuration setup of the device. The MC34921 also has two output registers -- the NORMAL output register reports A/D conversion data as well as digital encoder data, and the IREQ output register reports under voltage, temperature, and other device status data.

FUNCTIONAL TERMINAL DESCRIPTION

GROUND (GND)

Main ground. It is used for the B+ filters and motor filter grounds, as well as the ground return for external components which are used with the linear and switching regulators.

COVER VOLTAGE OUTPUT SELECT (VCORE SELECT)

This terminal is used to select the output voltage provided by the VCORE linear regulator. The VCORE Select potential is latched in during the MC34921's power-on sequence. The MC34921 will not respond to changes in VCORE Select after power up.

UNIPOLAR STEP A/DC MOTOR C OUTPUT A ($\overline{SA}/\text{CDCMA}$)

A low-side driver output is configurable for either stepper motor control (\overline{SA}) or C DC motor (as CDCMA, which requires an external hardwire to pin 63) via the serial I/O. The driver is PWM controlled via the CPWMA/CDCPWM pin, and direction controlled via the Serial I/O. It includes an active voltage clamp, current limit, and thermal shutdown protection.

UNIPOLAR STEP \overline{A} /DC MOTOR C OUTPUT B ($\overline{SA}/\text{CDCMB}$)

A low-side driver output is configurable for either stepper motor control (\overline{SA}) or C DC motor (as CDCMB, it requires external hardwire to pin 61) via the serial I/O. The driver is PWM controlled via the CPWMA/CDCPWM pin, and direction controlled via the Serial I/O. It includes active voltage clamp, current limit, and thermal shutdown protection.

UNIPOLAR STEP B/LOW-SIDE 1 ($\overline{SB}/\text{LSOUT1}$)

A low-side driver output is configurable for either stepper motor control (\overline{SB}) or as a general purpose low-side driver (LSOUT1) via the serial I/O. The \overline{SB} is PWM controlled via

the CPWMB pin. The direction and LSOUT1 are controlled via the serial I/O. It includes active voltage clamp, current limit and thermal shutdown protection.

UNIPOLAR STEP \overline{B} /LOW-SIDE 2 ($\overline{SB}/\text{LSOUT2}$)

A low-side driver output is configurable for either stepper motor control (\overline{SB}) or as a general purpose low-side driver (LSOUT2) via the serial I/O. The \overline{SB} is PWM controlled via the CPWMB pin. The direction and LSOUT2 are controlled via the serial I/O. It includes active voltage clamp, current limit and thermal shutdown protection.

POWER SUPPLY INPUT (B+)

This is the main power supply input for the regulators and DC motor drivers.

3.3 V SWITCHING REGULATOR SWITCH OUTPUT (3.3 V SWITCH)

The high-side driver output is used for the 3.3v switching regulator. It uses the internal 200KHZ clock.

3.3 V REGULATOR FEEDBACK (3.3 V)

This terminal is the error amp feedback for the 3.3v switching regulator. It is also the output point for the 3.3v switching supply.

CORE VOLTAGE REGULATOR INPUT (VCORE SUPPLY)

The input voltage terminal for the VCORE linear supply, which is usually provided by externally hardwiring the 3.3v switching regulator output.

CORE VOLTAGE REGULATOR OUTPUT (VCORE)

The output terminal of the VCORE linear regulator. Voltage options of 1.5v, 1.8v, or 2.5v are set by the potential of the VCORE Select pin at power up. It features current limit

and thermal shutdown protection. It is typically used to supply a micro processor core or embedded DRAM.

DC MOTOR A OUTPUT A (ADCMA)

A high-side and low-side driver output terminal, which when combined with ADCMB forms the A H-bridge DC motor driver. The driver is PWM controlled via the APWM input, and direction controlled via the Serial I/O. It features current limit and thermal shutdown protection.

DC MOTOR A OUTPUT B (ADCMB)

A high-side and low-side driver output terminal, which when combined with ADCMA forms the A H-bridge DC motor driver. The driver is PWM controlled via the APWM input and direction controlled via the Serial I/O. It features current limit and thermal shutdown protection.

BOOST VOLTAGE (VBOOST)

This is the boost voltage storage node for the charge pump circuit. It provides the gate drive voltage for the high-side FETS in the DC motor drivers, switch mode controllers, and Gateout pin.

SWITCHING CAPACITOR (CP1 AND CP2)

These are the connections for the charge pump flying capacitor.

HIGH-SIDE MOSFET GATE DRIVER (GATEOUT)

The output terminal for an external N-channel high-side driver. Enabled via the Serial I/O, it provides gate drive control for an external N-channel MOSFET high-side switch.

DC MOTOR B OUTPUT B (BDCMB)

A high-side and low-side driver output terminal, which when combined with BDCMA, forms the B H-bridge DC motor driver. The drivers are PWM controlled via the BPWM input, and direction controlled via the Serial I/O. It features current limit and thermal shutdown protection.

DC MOTOR B OUTPUT A (BDCMA)

A high-side and low-side driver output terminal, which when combined with BDCMB, forms the B H-bridge DC motor driver. The drivers are PWM controlled via the BPWM input, and direction controlled via the Serial I/O. It features current limit and thermal shutdown protection.

5.0 V REGULATOR MODE SELECT (5 V SELECT)

This terminal is used to set the 5v regulator to operate in either linear or switching mode. Ground this terminal to operate in switching mode, or float to operate in linear mode.

5.0 V REGULATOR SWITCH OUTPUT (5 V SWITCH)

This terminal is the high-side driver output used for the 5v switching regulator. It uses the internal 200KHZ clock.

5.0 V REGULATOR INPUT SUPPLY (5 V SUPPLY)

The input voltage terminal for the 5v regulator. Limit it to 20v in linear mode. An additional series resistor is recommended to dissipate power off-chip.

5.0 V REGULATOR FEEDBACK (5 V)

This is the 5v feedback input terminal and output voltage point for the 5v regulator when in the switch configuration, and the output pin when tied to 5v SWITCH in linear configuration. It is also the power supply terminal for the MC34921AE on board logic.

AN0/ANALOGOUT_A (AN0/ANALOGOUT_A)

Mux input 0 for the A/D converter, which is also available in Freescale test mode as an output for the AN2 I/V converter.

AN1/ANALOGOUT_B (AN1/ANALOGOUT_B)

Mux input 1 for the A/D converter, which is also available in Freescale test mode as an output for the AN3 I/V converter.

AN2/ANALOGIN_A (AN2/ANALOGIN_A)

Mux input 2 for the A/D converter incorporating an I/V converter with offset and gain calibration via the Serial I/O.

AN3/ANALOGIN_B (AN3/ANALOGIN_B)

Mux input 3 for the A/D converter incorporating an I/V converter with offset and gain calibration via the Serial I/O.

ANALOG ENCODER CHANNEL B FILTER (ENC_FILT_B)

Input to the AN3 I/V converter stage for feedback components used with the I/V converter op amp.

ANALOG ENCODER CHANNEL A FILTER (ENC_FILT_A)

Input to the AN2 I/V converter stage for feedback components used with the I/V converter op amp.

RESET ($\overline{\text{RST}}$)

Supervisory function I/O, incorporating a comparator input and an open drain output, and typically connected to the $\overline{\text{RST}}$ of a microprocessor. As an input, $\overline{\text{RST}}$ resets internal registers to default states, turns step motor outputs off, forces DC motor drive low-side drives on, and sets MISO to a high Z state. As an output, $\overline{\text{RST}}$ is set during B+ UVLO, all regulators UVLO, current limit, and thermal shutdown events.

MASTER IN SLAVE OUT (MISO)

This is the master-in-slave-out terminal; the serial output port of the Serial I/O, which typically connects to the MISO of a microprocessor. MISO reports two data frames: NORMAL

- A/D conversion and analog encoder signals, and INFO - Fault data and analog encoder signals.

The output data is loaded into the output shift register on each rising edge of SCLK, while \overline{CE} is held in a logic high state. This means the MISO pin shows the status of the most significant bit (bit 15) of the output frame until the first rising edge of SCLK after the \overline{CE} pin is taken to a logic low state. The shift register will then shift data out on the MISO pin on each subsequent rising edge of SCLK while \overline{CE} is held in the logic low state. During transfers, the most significant bit (MSB) is transferred first. After all 16 bits have been transferred, if any additional clocks are given while \overline{CE} is in a logic low state, the data is undefined and should be ignored.

MASTER OUT SLAVE IN (MOSI)

This is the master-out-slave-in terminal; the serial input port of the Serial I/O, which typically connects to the MOSI of a microprocessor. It has two frames of operation - NORMAL and CONFIG, which are set by a bit in the NORMAL frame. The MOSI pin is used for serial instruction data input. MOSI information is clocked into the input shift register on the rising edge of SCLK. A logic high state present on MOSI will program a register bit on. The specific bit will turn on with the 16th rising edge of SCLK after placing the \overline{CE} pin in a logic low state. Conversely, a logic low state present on the MOSI pin will program the register bit off. The specific bit will turn off with the 16th rising edge of SCLK after placing the \overline{CE} pin in a logic low state. For each rising edge of the SCLK while \overline{CE} is logic low, a data bit instruction (on or off) is loaded into the shift register per the data bit MOSI state. The last bit clocked in (bit 0) is the CONFIG bit. If this bit is in a logic high state at the 16th rising edge of SCLK after lowering the \overline{CE} pin, the bits in the shift register will be loaded into the CONFIG register. If the bit is in a low logic state, the bits will be loaded into the NORMAL register. Care should be taken to keep the MOSI pin in a logic low state when it is not being used for transfers to avoid erroneous data. During transfers, the most significant bit (MSB) is clocked in first.

SERIAL CLOCK (SCLK)

As the serial clock terminal, the SCLK pin clocks the internal shift registers of the MC34921. The serial data input (MOSI) pin data is latched into the input shift register on the rising edge of the 16th clock after the falling edge of the chip select (\overline{CE}) pin. The serial data output (MISO) pin shifts data out of the shift register on the rising edge of the SCLK signal. False clocking of the shift register must be avoided to ensure validity of data. It is essential that one rising edge of SCLK occur while \overline{CE} is in a logic high state to ensure the correct output data is latched into the output shift register. Clocking the SCLK pin for more than one clock period while \overline{CE} is in a logic high state is not recommended and may have undesired effects. For this reason, it is recommended that the SCLK pin be clocked only once while \overline{CE} is in a logic high state. The MC34921 is designed such that SCLK should be a continuous clock. This ensures that A/D sample rates are held as constant as possible.

CHIP ENABLE (\overline{CE})

The chip enable port of the Serial I/O, typically connects to the \overline{CE} of a microprocessor. The logic state of the \overline{CE} pin activates clocking in and shifting out of data in and out of the MC34921. While the \overline{CE} pin is in the logic high state, the output data in the NORMAL registers and the INFO registers are latched (depending on the state of the IREQ bit in the previous communication frame) in on each rising edge of the clock such that the state of the MSB (bit 15) is readable on the serial data output (MISO) pin. When \overline{CE} is in a low logic state both the input shift register and output shift register shift data at the rising edge of SCLK.

MOTOR DRIVER C PWM INPUT A (CPWMA / CDCPWM)

This is the PWM logic input for the $\overline{SA}/\overline{SB}/\overline{SC}$ motor drivers. The motor driver outputs follow this signal.

MOTOR DRIVER C PWM INPUT B (CPWMB)

This is the PWM logic input for the $\overline{SB}/\overline{SC}$ motor drivers. The motor driver outputs follow this signal.

DIGITAL GROUND (DGND)

This terminal is used for the Serial I/O and A/D converter logic grounds, and should be kept isolated from the Analog ground on the application PCB.

MOTOR DRIVER A PWM INPUT (APWM)

The PWM logic input terminal for the ADCM motor drivers. The motor driver outputs follow this signal.

MOTOR DRIVER B PWM INPUT (BPWM)

The PWM logic input terminal for the BDCM motor drivers. The motor driver outputs follow this signal.

MOTOR DRIVER C STEP MOTOR OUTPUT OR HIGH-SIDE OUTPUT 2 (CDCMB / HSOUT2)

The high-side driver output is configurable for either C DC motor control (as CDCMB, it requires external hardware to pin 4), or as a general purpose high-side driver (HSOUT2) via the serial I/O. The CDCMB is PWM controlled via the CPWMA/CDCPWM pin. The direction and HSOUT2 are controlled via the serial I/O. It includes current limit and thermal shutdown protection.

MOTOR DRIVER C STEP MOTOR OUTPUT OR HIGH-SIDE OUTPUT 1 (CDCMA / HSOUT1)

The high-side driver output is configurable for either C DC motor control (as CDCMA, it requires external hardware to pin 4), or as a general purpose high-side driver (HSOUT1) via the serial I/O. The CDCMA is PWM controlled via the CPWMA/CDCPWM pin. The direction and HSOUT1 are controlled via the serial I/O. It includes current limit and thermal shutdown protection.

FUNCTIONAL INTERNAL BLOCK DESCRIPTION

3.3 V Regulator Switching	DC Motor Drivers	Supervisory RST Function
5.0 V Regulator Switching and Linear	Step Motor Driver	A/D Convertor
V Core Linear Regulator	Charge Pump	Timing Logic

Figure 7. Internal Block Diagram

5.0 V AND 3.3 V REGULATORS

The 34921 5.0 V regulators have two operating modes—switching and linear—that share a dedicated input terminal, as illustrated in [Figure 8](#) and [Figure 9](#). The 5.0 V switching regulator operates off B+ directly. The 5.0 V linear regulator is only used when B+ < 20 V, and the dedicated input terminal is connected to B+ through an external power resistor to dissipate some power off-chip. The regulator that is used depends on the power requirement and B+NOM of the application. The designer is able to trade off power versus overall system cost for each particular application. The linear regulator mode is a low-current mode and has much less external component cost.

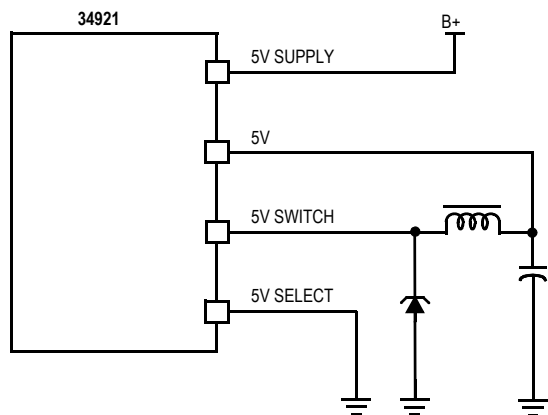

Figure 8. 5.0 V Switching Regulator Mode

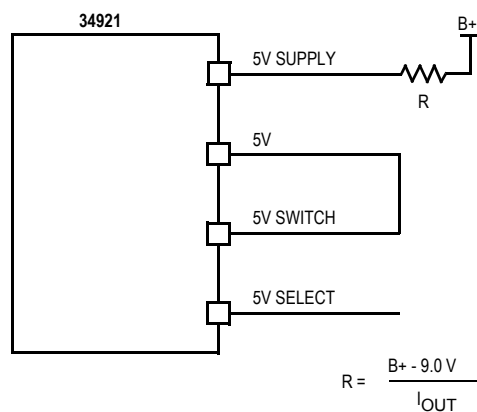

Figure 9. 5.0 V Linear Regulator Mode

The 5V SELECT terminal must be tied to ground for switching regulator mode. An internal pull-up is incorporated in the 34921 sufficient to avoid any problems owing to switching noise on this terminal.

The 5.0 V switching and linear regulators may supply external logic components of the overall assembly, depending on the application. For the 5.0 V linear regulator, an external capacitor on the output should be used for filtering.

5.0 V AND 3.3 V SWITCHING REGULATORS

The 5.0 V and 3.3 V switching regulators are implemented as constant ripple buck regulators. These regulators operate in both discontinuous and continuous mode. The clock source is the on-board 200 kHz master oscillator. The actual frequency of the switch terminal can vary owing to cycle skipping. The switch MOSFET is internal to the 34921 IC, but the remaining components—recovery diode, inductor, and output capacitor—must be externally supplied. The input voltage to the regulators is B+, and the regulators perform within specifications over the range of $I_{5.0} \leq 0.6 \text{ A}$ for the 5.0 V switching regulator and $I_{3.3} \leq 2.5 \text{ A}$ for the 3.3 V switching regulator. Each has cycle-by-cycle current limiting.

The power up sequence of the 5.0 V and 3.3 V switching regulators is controlled such that $-1.0\text{v} \leq V_5 - V_{3.3} \leq 2.6\text{v}$. [Figure 10](#) depicts the power-up sequence for the 5.0 V and 3.3 V regulators.

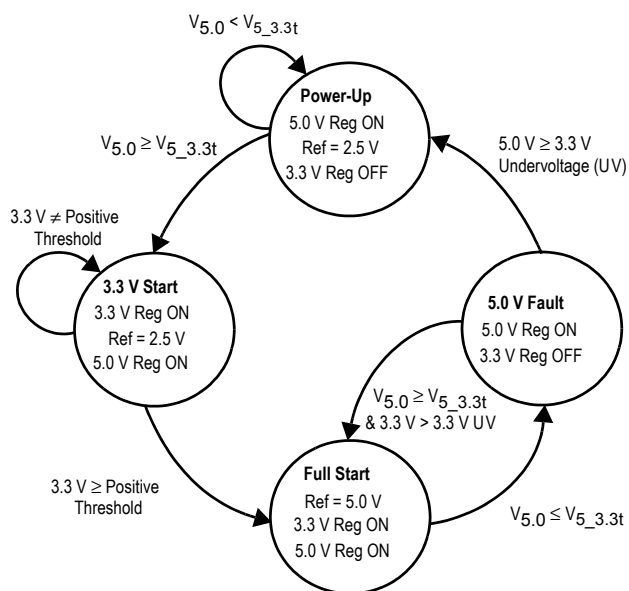

Figure 10. Power-Up Sequencing

VCORE LINEAR REGULATOR

The output voltage of the V_{CORE} linear regulator is selectable for different applications. The output is selected with an external pull-up or pull-down, which instructs internal logic to select the appropriate regulator set-point (refer to [Table 5](#)). The V_{CORE} linear regulator is available whenever the 3.3 V supply is in stable operation.

Current limiting is implemented to provide short circuit protection. The V_{CORE} linear regulator is shut off by the local thermal shutdown sensor, thus protecting the 34921 IC from an over-temperature condition resulting from a V_{CORE} short circuit, but otherwise allowing V_{CORE} to follow the 3.3 V switching regulator.

The V_{CORE} SUPPLY terminal is the drain or collector of the linear regulator transistor and must be tied to the 3.3V terminal to use the internal regulator. This allows the option of using an external regulator if the internal 3.3 V regulator cannot supply enough current for a particular application. Use of an external regulator requires leaving this terminal open, thus disabling the internal regulator. The output of the

external regulator is then connected to the V_{CORE} terminal for under-voltage monitoring.

Table 5. V_{CORE} Regulator Output Voltage Select

V _{CORE} SELECT	V _{CORE_NOM} (Volts)
Tied to Ground terminal	1.5
Tied to 3.3V terminal	1.8
Floating	2.5

DC MOTOR DRIVERS

There are two DC motor drivers on the 34921 IC: if used in a printer application, for example, they might be the carriage motor driver and the paper motor driver. A third drive, Motor Driver C, can be configured as a DC motor driver or, when $B^+_{NOM} = 18\text{ V}$, as a step motor driver (refer to succeeding paragraph [Step Motor Driver](#)). Configuration bit 13 determines the mode: 0 = step mode, 1 = DC mode. A step motor driver can only be used in $B^+ = 12\text{ V}$ to 20 V applications. Step motor outputs are suppressed by the internal supervisor for $B^+ > 20\text{ V}$. The ability to use the low-side MOSFETs for general purpose low-side outputs is included when the system is in DC motor mode (LSOUTx). Alternatively, the ability to use the high-side MOSFETs for general purpose high-side outputs (HSOUTx) has been included when the system is in step mode. (Refer to [Table 20](#), page 31, and [Table 21](#), page 32.)

The DC motor drivers are pulse width modulated (PWM'd) via inputs from the digital subsystem on the APWM and BPWM terminals, respectively. This signal is approximately 20 kHz to 40 kHz. The DC motor driver bridge direction may be reversed while there is significant current flowing in the motor. The purpose of this action is to brake the motor by rapidly lowering the current. There are pull-downs on the PWM input terminals so that, in the event of a connection failure, the driver will default to a safe condition.

The DC motor drivers provide high-side and low-side current limiting. The current limits have a 0.5 μs to 6.0 μs deglitch filter, followed by an off-timer. The off-timer shuts off the bridge long enough to meet the 4% duty cycle goal. The motor drivers also have thermal shutdown protection.

STEP MOTOR DRIVER C

Step motor driver C can be configured as a DC motor driver or, when $B^+_{NOM} = 18\text{ V}$, as a step motor driver (refer to succeeding paragraph [Step Motor Driver](#)). Configuration bit 13 determines the mode: 0 = step mode, 1 = DC mode. The ability to use the low-side MOSFETs for general purpose low-side outputs is included when the system is in DC motor mode (LSOUTx). Alternatively, the ability to use the high-side MOSFETs for general purpose high-side outputs (HSOUTx) has been included when the system is in step mode. (Refer to [Table 20](#), page 31, and [Table 21](#), page 32.)

Step motor driver C is PWM'd via an input from the digital subsystem on the CPWMA/CDCPWM terminal. This signal is approximately 20 kHz to 40 kHz. There are pull-downs on the PWM input terminals so that DC motor drive C will default to a safe condition in the event of a connection failure.

STEP MOTOR DRIVER

A step motor driver can be configured as a DC motor driver (refer to preceding paragraph [DC Motor Drivers](#)) or, when $B^+_{NOM} \leq 20\text{ V}$, as a unipolar step driver. Serial input configuration frame bit 4 determines the mode: 0 = step mode, 1 = DC mode. A step motor driver will only be used in $B^+ = 12\text{ V}$ to 20 V applications.

Note It is possible to use the step motor driver with $B^+ > 20\text{ V}$ if the step motor is driven from a separate supply that is $\leq 20\text{ V}$.

The step motor driver on the 34921 is a unipolar, voltage-mode wave drive circuit employing synchronous rectification. The centertap of each phase-counterphase pair is connected to B^+ .

Two PWM signals are sent directly from the digital subsystem. The CPWMA/CDCPWM terminal provides the PWM signal for the A and \bar{A} outputs. The CPWMB terminal provides the PWM signal for the B and \bar{B} outputs. The step motor driver employs synchronous rectification to control substrate currents. In synchronous rectification, when an output is turned off, the counterphase output MOSFET is turned on to maintain current continuity. In order to avoid a large shoot-through current, there is a dead time delay (t_{delay}) between phase off and counterphase on. Refer to [Figure 5, Step Motor Crossover Delay Timing](#), page [16](#).

VBOOST CHARGE PUMP

The high-side MOSFETs in the DC motor H-bridges and the external GATEOUT switch need a gate voltage in excess of B^+ , which is provided by the VBOOST supply. The VBOOST regulator is a charge pump, switching directly off the B^+ supply and operating at 200 kHz.

EXTERNAL N-FET GATE DRIVE OUTPUT

The GATEOUT terminal is an output for a high-side N-channel MOSFET gate drive. The output will be used to drive an external high-side MOSFET switch (see figure below). When enabled, GATEOUT will be connected to the V_b supply. The edge rates when switching the transistors must be controlled so that shoot-through current does not affect B^+ .

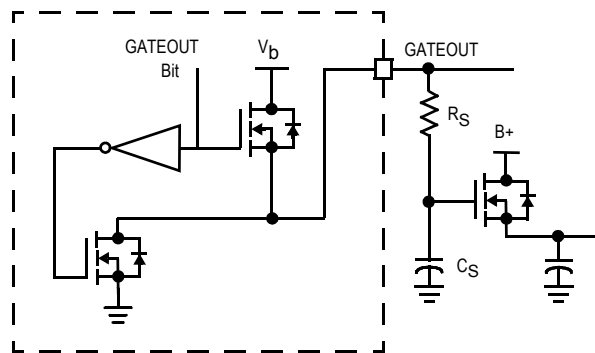

Figure 11. External N-FET Gate Drive Circuit

CLOCKING SCHEMES

There are two basic clocking schemes that can be used while clocking data into the MC34921 IC. One has 16 rising edges of SCLK while \overline{CE} is in a logic low state and the other has 15 rising edges of SCLK. In the 15 SCLK clocking scheme, the input data and output data are latched on the same clock edge. In the timing diagram on page [16](#), the numbers on the MOSI line are the bits that will be clocked into the input shift register at the rising edge of SCLK. They are drawn occurring before SCLK to account for the required setup time (minimum 15ns). The numbers on the MISO line are the bits that will be clocked out at the rising edge of SCLK. They are drawn occurring after SCLK to account for the output delay from the rising edge of SCLK (maximum 40ns). The numbers on the SCLK line are for reference only.

Note: when using the 15 bit clocking method with exactly one rising edge of SCLK when \overline{CE} is in a logic high state, the output data to be sent out is latched at the same time the IREQ bit is latched in. The next frame following the assertion of the IREQ bit is the IREQ data. I.e., the frame after the sending of the IREQ bit will have the data from the IREQ register rather than skipping one frame. **Note:** regarding the reporting of the DONE bit after the completion of an A/D conversion: the DONE bit is sent out every time a conversion completes. This requires the user to hold the MOSI pin in a low state when it is not being used to transmit data. Refer to [Figure 4, Serial Interface Timing](#) and [Figure 5, Step Motor Crossover Delay Timing](#)

SUPERVISORY (RST) FUNCTION

Supervisory Circuitry

The supervisor circuitry provides control of the \overline{RST} line, an open drain signal, based on system operating conditions monitored by the 34921 IC. $V_{5.0}$, $V_{3.3}$, V_{CORE} , B^+ , and thermal shutdown detectors in various parts of the chip are monitored for error conditions. Because other devices in the system may trigger a reset, the \overline{RST} line itself is also monitored, but the supervisor circuitry controls all reset timing, including externally generated resets. Driving the \overline{RST} line low causes the system to be held in the reset state. $V_{5.0}$,

$V_{3.3}$, V_{CORE} , $B+$, and TSD have both positive- and negative-going thresholds.

Static Operating Specifications

The state of \overline{RST} is guaranteed as long as the minimum supervisor operating conditions of $B+ \geq 9.0$ V and $V_{5.0} \geq 2.0$ V and $V_{3.3} \geq 1.5$ V and V_{CORE} are met. Once all these conditions are met, \overline{RST} is dependent on system operating conditions. During initial power-up, \overline{RST} is held low if any one of the following error conditions is present: +5.0 V(low), V_{CORE} (low), +3.3 V(low), $B+$ (low), or TSD. Once all voltages reach their positive-going threshold, \overline{RST} is set high after the appropriate timing.

Dynamic Operating Specifications

The \overline{RST} is a bidirectional signal with an open drain output driver and a CMOS digital input gate (see Figure 12). This I/O structure allows wired OR connection to the CPU's \overline{RST} I/O terminal, as well as allowing the CPU to initiate a reset cycle by driving its \overline{RST} terminal low. When responding to a CPU request for a reset cycle, the 34921 IC must respond rapidly enough to prevent a glitch. Figure 6, *RST Timing*, page 17, shows the timing parameters for responding to an externally applied \overline{RST} signal.

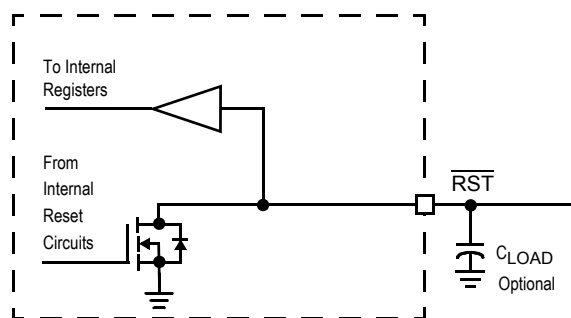

Figure 12. \overline{RST} Terminal Interface

The rise time with the open drain circuit may be relatively slow, and the internal \overline{RST} input gate must operate reliably (no oscillations during the transition) under these conditions;

Table 6. Regulator Shutdown Schedule

Condition	XDCMA ⁽²⁶⁾	XDCMB ⁽²⁶⁾	\overline{SX}	\overline{SX}	5.0 V	V_{CORE}	3.3 V	Fault Registers	Other Data Registers
\overline{RST}	0	0	OFF	OFF	ON	ON	ON	Updated at falling \overline{RST}	Default value
TSD and \overline{RST}	Z	Z	OFF	OFF	OFF	ON	OFF	Updated at falling \overline{RST}	Default value
TSDCore and \overline{RST}	Z	Z	OFF	OFF	OFF	OFF	OFF	Updated at falling \overline{RST}	Default value

Notes

26. XDCMA and XDCMB: 0 means low-side ON, 1 means high-side ON, Z means both OFF.

ANALOG ENCODER INTERFACE

Introduction

The analog encoder interface is intended to provide a

i.e., the \overline{RST} input can be inhibited for up to t_{phsl} (max). Error conditions must be present for a minimum time, t_{filter} , before the 34921 responds to them. Once all error conditions are cleared, \overline{RST} is held low for an additional time of t_{delay} , 128 SCLK periods. If any monitored item falls below its negative-going threshold for t_{filter} , 1.5 μ s to 5.0 μ s, the t_{delay} count is restarted when system operating conditions are met, regardless of whether the t_{delay} count has been completed. The trigger for the t_{delay} retriggerable one shot is $([+5.0$ V(low) + 3.3 V(low) + V_{CORE} (low) + $B+$ (low) + TSD] and t_{filter}), where t_{filter} is the 1.5 μ s to 5.0 μ s delay.

\overline{RST} and Thermal Shutdown State (TSD) Definition

There are seven registers in the INFO output word where the trigger for the reset is recorded. This includes externally generated resets as well as all the fault conditions listed in the Supervisory Functions section of this datasheet. These registers will remain valid as long as $B+ \geq 9.0$ V. The fault registers will only be cleared upon an externally generated \overline{RST} and will not be guaranteed for $B+ < 9.0$ V; i.e., initial power-up or a serious $B+$ fault. The EXT bit will only be set upon an externally generated reset.

Whenever \overline{RST} is asserted and TSD is not set, the MISO terminal will enter a high-impedance state, all the step motor outputs will be off, and all the DC motor low-side drives will be on. In addition, all internal data registers excepting the \overline{RST} fault registers in the INFO output word will be set to their default values.

The thermal shutdown circuitry will monitor the chip's internal temperature at various points. The overtemperature circuitry will disable all circuitry on the 34921 IC with the exception of the \overline{RST} output. \overline{RST} will be asserted when the temperature exceeds 140°C. This condition will be maintained (regulators shut down in accordance with Table 6, page 24) until the die temperature falls by the thermal hysteresis amount, at which time the 5.0 V and 3.3 V regulators will restart and the supervisor circuit will issue a full length reset pulse. The system will then perform a normal restart. The purpose of this circuitry is to prevent damage to the 34921 owing to inadvertent high dissipation in the motor drivers.

complete interface for an analog quadrature encoder, such as an Agilent Technologies HEDS-9710/HEDS-9711 series of analog output small optical encoder modules.

The Agilent HEDS-9710/HEDS-9711 incremental analog quadrature encoder is a 200 lpi encoder that outputs a quadrature analog current reflecting the position of the encoder codewheel/codestrip within the encoder. The analog encoder interface must provide six functions to support this encoder: force a bias point of 1.3 V, current-to-voltage conversion, offset current nulling, output amplitude adjust

(variable gain), channel inversion, and digital phase generation (see [Figure 13](#)).

Note: Freescale does not assume liability, endorse, or warrant components from external manufacturers that are referenced in this document. While Freescale offers component recommendations, it is the customer's responsibility to validate their application.

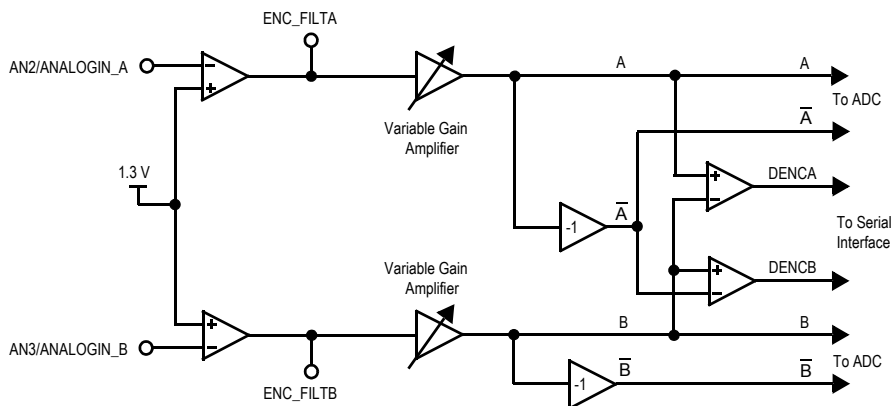

Figure 13. Analog Encoder Interface Block Diagram

I/V Conversion Stage

The I/V conversion stage is carried out by a transimpedance amplifier using an external resistor. There is a resistor to ground at the ANALOGIN_x input to allow offset current trim and force the proper bias point on the encoder. The feedback resistor should be sized to accommodate ± 2.5 V output voltage swing for the full encoder current waveform. For example, if the encoder produces a ± 50 μ A signal, the feedback resistor needs to be 50 k Ω .

The resistor to ground must have a specific relationship to the feedback resistor. It needs to be 1.17 times the feedback resistor, or 58.5 k Ω for the example above. This ensures that the encoder is biased at 1.35 V, and that the output of the transimpedance amplifier is 2.5 V.

The I/V conversion stage can trim an encoder offset current of up to ± 8.0 μ A in the encoder output.

Variable Gain Amplifier

The I/V conversion stage is followed by a variable gain amplifier that can compensate for variations in the encoder output. This is designed to accommodate manufacturing variations in the encoder, as well as aging and other effects. The gain can be changed over the serial interface at any time.

The output of the variable gain amplifiers can be routed to the ANALOGOUT_x terminals for engineering evaluation. Otherwise, these terminals are general purpose A/D inputs.

Channel Inversion and Digital Phase Generation

The A and B channels are inverted by applying the function $\overline{\text{CHANNELx}} = 2.5 \text{ V} - \text{CHANNELx}$. This results in four signals: A, B, $\overline{\text{A}}$, and $\overline{\text{B}}$. These signals are used produce the digital encoder signals DENCA and DENCBA, which are converted by the ADC to provide the analog position

information. The value of the DENCA and DENCBA signals determine which signal—A, B, $\overline{\text{A}}$, or $\overline{\text{B}}$ —is converted. Refer to [Table 7](#), page 26, for more information.

Position Information

The entire position information is produced by concatenating the value of the a quadrature counter, driven by DENCA and DENCBA bits, and the 8 bits of “fractional” information from the ADC.

Calibration of the Encoder

It is necessary to adjust the gain and offset of the I/V circuit initially and periodically to compensate for encoder-to-encoder variation, aging, and other effects. The ADC “double conversion” function allows this by continuously sampling the A and B signals, allowing a map of the encoder output to be built up. The user will need to provide the necessary algorithm to use the waveform map to produce gain and offset calibration values for both channels.

ANALOG-TO-DIGITAL CONVERTER

Introduction

There is an 8-bit analog-to-digital converter (ADC) on the 34921 IC that uses the on-board voltage reference and derives all the necessary timing signals from the SCLK input. The ADC is referenced to the same ground as the system ground (GND).

ADC Input Selection

The ADC has an 8-channel analog multiplexer so that all inputs share one ADC. The input(s) to be converted are