



Chipsmall Limited consists of a professional team with an average of over 10 year of expertise in the distribution of electronic components. Based in Hongkong, we have already established firm and mutual-benefit business relationships with customers from,Europe,America and south Asia,supplying obsolete and hard-to-find components to meet their specific needs.

With the principle of “Quality Parts,Customers Priority,Honest Operation,and Considerate Service”,our business mainly focus on the distribution of electronic components. Line cards we deal with include Microchip,ALPS,ROHM,Xilinx,Pulse,ON,Everlight and Freescale. Main products comprise IC,Modules,Potentiometer,IC Socket,Relay,Connector.Our parts cover such applications as commercial,industrial, and automotives areas.

We are looking forward to setting up business relationship with you and hope to provide you with the best service and solution. Let us make a better world for our industry!



Contact us

Tel: +86-755-8981 8866 Fax: +86-755-8427 6832

Email & Skype: info@chipsmall.com Web: www.chipsmall.com

Address: A1208, Overseas Decoration Building, #122 Zhenhua RD., Futian, Shenzhen, China



Dual Intelligent High-current Self-protected Silicon High-side Switch (4.0 mOhm)

The 34984 is a dual self-protected 4.0 mOhm switch used to replace electromechanical relays, fuses, and discrete devices in power management applications. The 34984 is designed for harsh environments, and it includes self-recovery features. The device is suitable for loads with high inrush current, as well as motors and all types of resistive and inductive loads.

Programming, control and diagnostics are implemented via the serial peripheral interface (SPI). A dedicated parallel input is available for alternate and pulse-width modulation (PWM) control of each output. SPI-programmable fault trip thresholds allow the device to be adjusted for optimal performance in the application.

The 34984 is packaged in a power-enhanced 12 x 12 mm nonleaded PQFN package with exposed tabs and powered by SMARTMOS technology.

Features

- Dual 4.0 mΩ max. high-side switch with parallel input or SPI control
- 6.0 V to 27 V operating voltage with standby currents < 5.0 μA
- Output current monitoring with two SPI-selectable current ratios
- SPI control of overcurrent limit, overcurrent fault blanking time, output OFF open load detection, output ON/OFF control, watchdog timeout, slew-rates, and fault status reporting
- SPI status reporting of overcurrent, open and shorted loads, overtemperature, undervoltage and overvoltage shutdown, fail-safe pin status, and program status
- Enhanced -16 V reverse polarity V_{PWR} protection

34984

HIGH-SIDE SWITCH

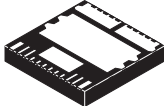

**BOTTOM VIEW
 FK SUFFIX
 98ARL10521D
 16-PIN PQFN**

Applications

- Low-voltage factory automation
- DC motor or solenoid
- Resistive and inductive loads
- Low-voltage industrial lighting

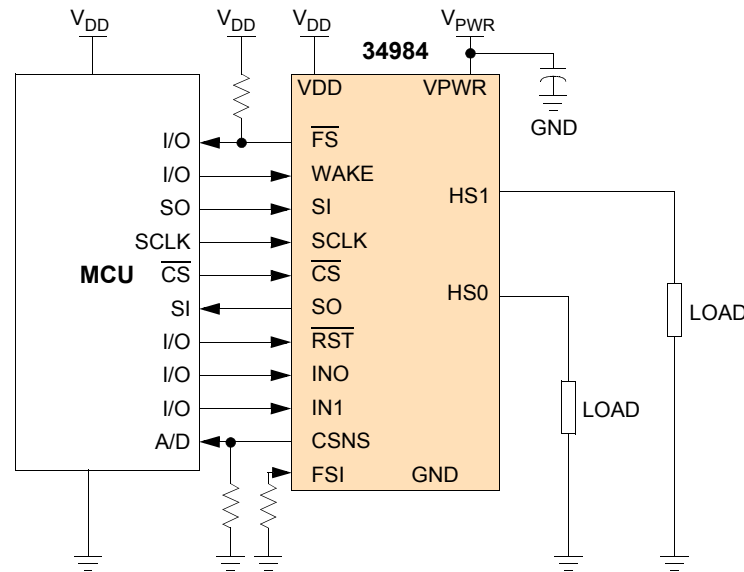

Figure 1. 34984 Simplified Application Diagram

ORDERABLE PARTS

Table 1. Orderable Part Variations

Part Number	Temperature Range (T _A)	Package
MC34984CHFK ⁽¹⁾	-40 °C to 125 °C	16 PQFN

Notes

1. To order parts in Tape & Reel, add the R2 suffix to the part number.

INTERNAL BLOCK DIAGRAM

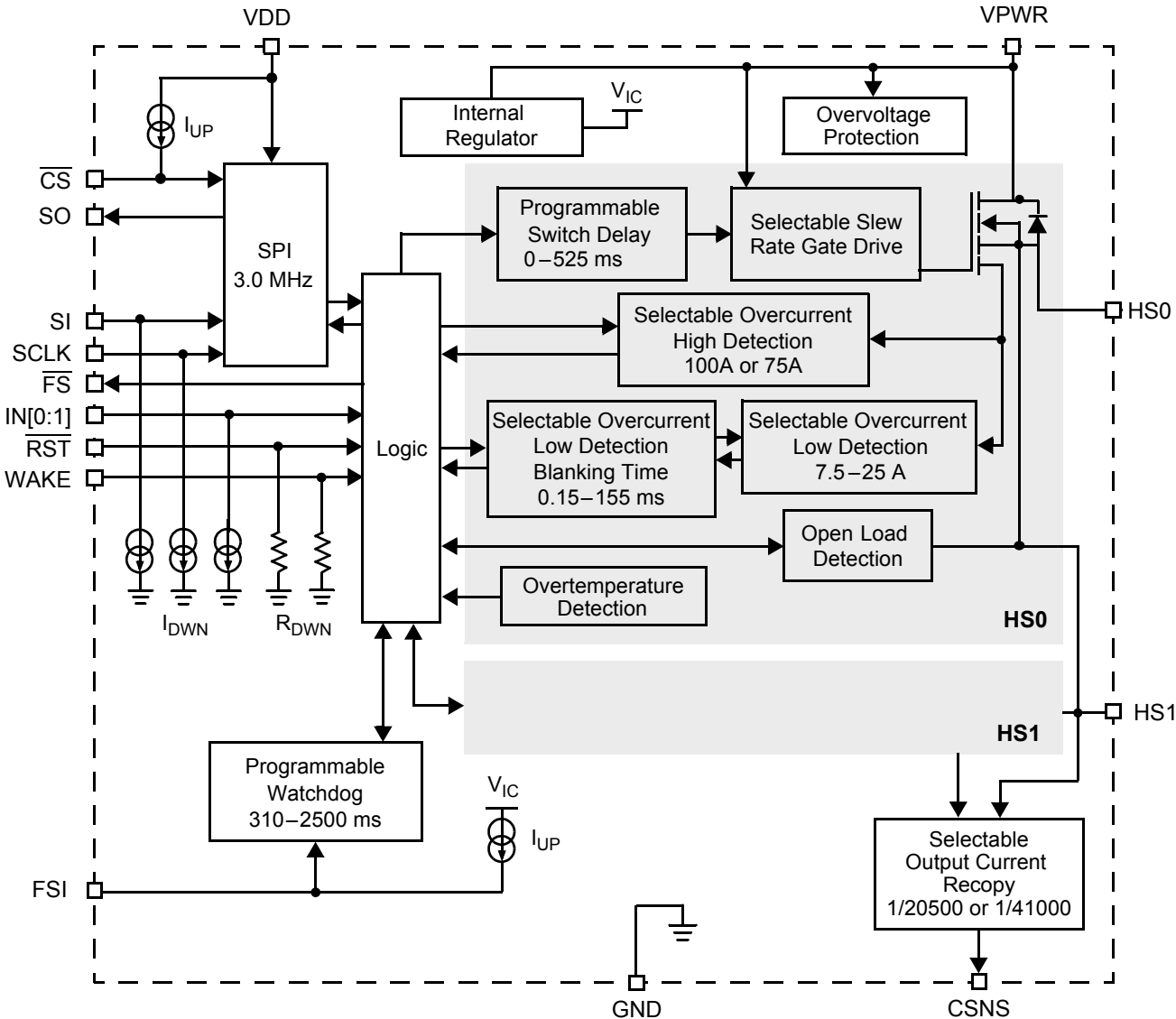

Figure 2. 34984 Simplified Internal Block Diagram

PIN CONNECTIONS

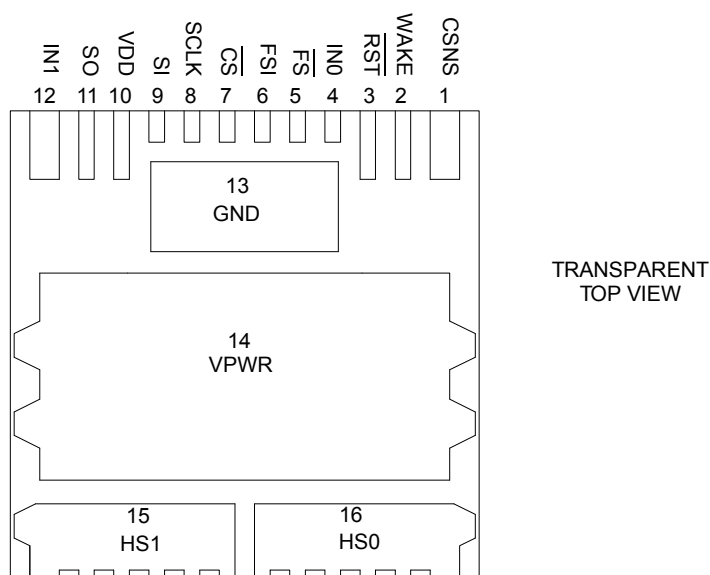

Figure 3. 34984 Pin Connections (Transparent Top View)

Functional descriptions of many of these pins can be found in the Functional Pin Description section beginning on [page 16](#).

Table 2. Pin Definitions

Pin	Pin Name	Pin Function	Formal Name	Definition
1	CSNS	Output	Output Current Monitoring	This pin is used to output a current proportional to the designated HS0-1 output.
2	WAKE	Input	Wake	This pin is used to input a Logic [1] signal so as to enable the watchdog timer function.
3	$\overline{\text{RST}}$	Input	Reset (Active Low)	This input pin is used to initialize the device configuration and fault registers, as well as place the device in a low current Sleep mode.
4	IN0	Input	Direct Input 0	This input pin is used to directly control the output HS0.
5	$\overline{\text{FS}}$	Output	Fault Status (Active Low)	This is an open drain configured output requiring an external pull-up resistor to VDD for fault reporting.
6	FSI	Input	Fail-safe Input	The value of the resistance connected between this pin and ground determines the state of the outputs after a watchdog timeout occurs.
7	$\overline{\text{CS}}$	Input	Chip Select (Active Low)	This input pin is connected to a chip select output of a master microcontroller (MCU).
8	SCLK	Input	Serial Clock	This input pin is connected to the MCU providing the required bit shift clock for SPI communication.
9	SI	Input	Serial Input	This is a command data input pin connected to the SPI Serial Data Output of the MCU or to the SO pin of the previous device of a daisy chain of devices.
10	VDD	Input	Digital Drain Voltage (Power)	This is an external voltage input pin used to supply power to the SPI circuit.
11	SO	Output	Serial Output	This output pin is connected to the SPI serial data input pin of the MCU or to the SI pin of the next device of a daisy chain of devices.
12	IN1	Input	Direct Input 1	This input pin is used to directly control the output HS1.
13	GND	Ground	Ground	This pin is the ground for the logic and analog circuitry of the device.
14	VPWR	Input	Positive Power Supply	This pin connects to the positive power supply and is the source input of operational power for the device.

Table 2. Pin Definitions (continued)

Pin	Pin Name	Pin Function	Formal Name	Definition
15	HS1	Output	High-side Output 1	Protected 4.0 mΩ high-side power output to the load.
16	HS0	Output	High-side Output 0	Protected 4.0 mΩ high-side power output to the load.

ELECTRICAL CHARACTERISTICS

MAXIMUM RATINGS

Table 3. Maximum Ratings

All voltages are with respect to ground unless otherwise noted.

Symbol	Rating	Value	Unit	Notes
ELECTRICAL RATINGS				
V_{PWR}	Operating Voltage Range Steady-state	-16 to 41	V	
V_{DD}	VDD Supply Voltage	-0.3 to 5.5	V	
$V_{IN[0:11]}$, \overline{RST} , FSI, CSNS, SI, SCLK, CS, FS	Input/Output Voltage	-0.3 to 7.0	V	(2)
V_{SO}	SO Output Voltage	-0.3 to $V_{DD}+0.3$	V	(2)
$I_{CL(WAKE)}$	WAKE Input Clamp Current	2.5	mA	
$I_{CL(CSNS)}$	CSNS Input Clamp Current	10	mA	
V_{HS}	Output Voltage Positive Negative	41 -15	V	
$I_{HS[0:1]}$	Output Current	30	A	(3)
$E_{CL[0:1]}$	Output Clamp Energy 34984B 34984C	0.75 0.5	J	(4)
V_{ESD1} V_{ESD3}	ESD Voltage Human Body Model (HBM) Charge Device Model (CDM) Corner Pins (1, 12, 15, 16) All Other Pins (2, 11, 13, 14)	± 2000 ± 750 ± 500	V	(5)

Notes

2. Exceeding this voltage limit may cause permanent damage to the device.
3. Continuous high-side output current rating so long as maximum junction temperature is not exceeded. Calculation of maximum output current using package thermal resistance is required.
4. Active clamp energy using single-pulse method ($L = 16$ mH, $R_L = 0$, $V_{PWR} = 12$ V, $T_J = 150$ °C).
5. ESD1 testing is performed in accordance with the Human Body Model (HBM) ($C_{ZAP} = 100$ pF, $R_{ZAP} = 1500$ Ω); ESD3 testing is performed in accordance with the Charge Device Model (CDM), Robotic ($C_{ZAP} = 4.0$ pF).

Table 3. Maximum Ratings (continued)

All voltages are with respect to ground unless otherwise noted.

Symbol	Rating	Value	Unit	Notes
THERMAL RATINGS				
T_A T_J	Operating Temperature Ambient Junction	-40 to 125 -40 to 150	°C	
T_{STG}	Storage Temperature	-55 to 150	°C	
$R_{\theta JC}$ $R_{\theta JA}$	Thermal Resistance Junction-to-Case Junction-to-Ambient	<1.0 30	°C/W	(7)
T_{PPRT}	Peak Package Reflow Temperature During Reflow	Note 9	°C	(8), (9)

Notes

6. To achieve high reliability over 10 years of continuous operation, the device's continuous operating junction temperature should not exceed 125 °C.
7. Device mounted on a 2s2p test board according to JEDEC JESD51-2.
8. Pin soldering temperature limit is for 40 seconds maximum duration. Not designed for immersion soldering. Exceeding these limits may cause malfunction or permanent damage to the device.
9. Freescale's Package Reflow capability meets Pb-free requirements for JEDEC standard J-STD-020. For Peak Package Reflow Temperature and Moisture Sensitivity Levels (MSL), Go to www.freescale.com, search by part number [e.g. remove prefixes/suffixes and enter the core ID to view all orderable parts. (i.e. MC33xxxD enter 33xxx), and review parametrics.

STATIC ELECTRICAL CHARACTERISTICS

Table 4. Static Electrical Characteristics

Characteristics noted under conditions $4.5\text{ V} \leq V_{DD} \leq 5.5\text{ V}$, $6.0\text{ V} \leq V_{PWR} \leq 27\text{ V}$, $-40\text{ }^\circ\text{C} \leq T_A \leq 125\text{ }^\circ\text{C}$, unless otherwise noted. Typical values noted reflect the approximate parameter mean at $T_A = 25\text{ }^\circ\text{C}$ under nominal conditions, unless otherwise noted.

Symbol	Characteristic	Min	Typ	Max	Unit	Notes
--------	----------------	-----	-----	-----	------	-------

POWER INPUT

V_{PWR}	Power Supply Voltage Range Full Operational	6.0	–	27	V	
$I_{PWR(ON)}$	VPWR Operating Supply Current Output ON, I_{HS0} and $I_{HS1} = 0\text{ A}$	–	–	20	mA	
$I_{PWR(SBY)}$	VPWR Supply Current Output OFF, Open Load Detection Disabled, $WAKE > 0.7 \times V_{DD}$, $\overline{RST} = V_{LOGIC\ HIGH}$	–	–	5.0	mA	
$I_{PWR(SLEEP)}$	Sleep State Supply Current ($V_{PWR} < 14\text{ V}$, $\overline{RST} < 0.5\text{ V}$, $WAKE < 0.5\text{ V}$) $T_J = 25\text{ }^\circ\text{C}$ $T_J = 85\text{ }^\circ\text{C}$	– –	– –	10 50	μA	
$V_{DD(ON)}$	VDD Supply Voltage	4.5	5.0	5.5	V	
$I_{DD(ON)}$	VDD Supply Current No SPI Communication 3.0 MHz SPI Communication	– –	– –	1.0 5.0	mA	
$I_{DD(SLEEP)}$	VDD Sleep State Current	–	–	5.0	μA	
$V_{PWR(OV)}$	Overvoltage Shutdown Threshold	28	32	36	V	
$V_{PWR(OVHYS)}$	Overvoltage Shutdown Hysteresis	0.2	0.8	1.5	V	
$V_{PWR(UV)}$	Undervoltage Output Shutdown Threshold	5.0	5.5	6.0	V	(10)
$V_{PWR(UVHYS)}$	Undervoltage Hysteresis	–	0.25	–	V	(11)
$V_{PWR(UVPOR)}$	Undervoltage Power-ON Reset	–	–	5.0	V	

POWER OUTPUT

$R_{DS(on)}$	Output Drain-to-Source ON Resistance ($I_{HS[0:1]} = 15\text{ A}$, $T_J = 25\text{ }^\circ\text{C}$) $V_{PWR} = 6.0\text{ V}$ $V_{PWR} = 10\text{ V}$ $V_{PWR} = 13\text{ V}$	– – –	– – –	6.0 4.0 4.0	$\text{m}\Omega$	
$R_{DS(on)}$	Output Drain-to-Source ON Resistance ($I_{HS[0:1]} = 15\text{ A}$, $T_J = 150\text{ }^\circ\text{C}$) $V_{PWR} = 6.0\text{ V}$ $V_{PWR} = 10\text{ V}$ $V_{PWR} = 13\text{ V}$	– – –	– – –	10.2 7.2 6.8	$\text{m}\Omega$	
$R_{DS(on)}$	Output Source-to-Drain ON Resistance $I_{HS[0:1]} = 15\text{ A}$, $T_J = 25\text{ }^\circ\text{C}$ $V_{PWR} = -12\text{ V}$	–	–	8.0	$\text{m}\Omega$	(12)
I_{OCH0} I_{OCH1}	Output Overcurrent High Detection Levels ($9.0\text{ V} \leq V_{PWR} \leq 16\text{ V}$) SOCH = 0 SOCH = 1	80 60	100 75	120 90	A	

Notes

10. This applies to all internal device logic supplied by V_{PWR} and assumes the external V_{DD} supply is within specification.
11. This applies when the undervoltage fault is not latched ($IN[0:1] = 0$).
12. Source-Drain ON Resistance (Reverse Drain-to-Source ON Resistance) with negative polarity V_{PWR} .

Table 4. Static Electrical Characteristics (continued)

Characteristics noted under conditions $4.5\text{ V} \leq V_{DD} \leq 5.5\text{ V}$, $6.0\text{ V} \leq V_{PWR} \leq 27\text{ V}$, $-40\text{ }^\circ\text{C} \leq T_A \leq 125\text{ }^\circ\text{C}$, unless otherwise noted. Typical values noted reflect the approximate parameter mean at $T_A = 25\text{ }^\circ\text{C}$ under nominal conditions, unless otherwise noted.

Symbol	Characteristic	Min	Typ	Max	Unit	Notes
POWER OUTPUT (CONTINUED)						
I _{OCL0} I _{OCL1} I _{OCL2} I _{OCL3} I _{OCL4} I _{OCL5} I _{OCL6} I _{OCL7}	Overcurrent Low Detection Levels (SOCL[2:0])					
	000	21	25	29		
	001	18	22.5	27		
	010	16	20	24		
	011	14	17.5	21	A	
	100	12	15	18		
	101	10	12.5	15		
	110	8.0	10	12		
111	6.0	7.5	9.0			
C _{SR0} C _{SR1}	Current Sense Ratio ($9.0\text{ V} \leq V_{PWR} \leq 16\text{ V}$, $CSNS \leq 4.5\text{ V}$)					
	DICR D2 = 0 DICR D2 = 1	– –	1/20500 1/41000	– –	– –	
C _{SR0_ACC}	Current Sense Ratio (C _{SR0}) Accuracy					
	Output Current					
	5.0 A	-20	–	20		
	10 A	-14	–	14	%	
	12.5 A	-13	–	13		
	15 A	-12	–	12		
20 A	-13	–	13			
25 A	-13	–	13			
C _{SR1_ACC}	Current Sense Ratio (C _{SR1}) Accuracy					
	Output Current					
	5.0 A	-25	–	25		
	10 A	-19	–	19	%	
	12.5 A	-18	–	18		
	15 A	-17	–	17		
20 A	-18	–	18			
25 A	-18	–	18			
V _{CL(CSNS)}	Current Sense Clamp Voltage CSNS Open; I _{HS[0:1]} = 29 A	4.5	6.0	7.0	V	
I _{OLDC}	Open Load Detection Current	30	–	100	μA	(13)
V _{OLD(THRES)}	Output Fault Detection Threshold Output Programmed OFF	2.0	3.0	4.0	V	
V _{CL}	Output Negative Clamp Voltage 0.5 A ≤ I _{HS[0:1]} ≤ 2.0 A, Output OFF	-20	–	-15	V	
T _{SD}	Overtemperature Shutdown	160	175	190	°C	(14)
T _{SD(HYS)}	Overtemperature Shutdown Hysteresis	5.0	–	20	°C	(14)

Notes

13. Output OFF open load detection current is the current required to flow through the load for the purpose of detecting the existence of an open load condition when the specific output is commanded OFF.
14. Guaranteed by process monitoring. Not production tested.

Table 4. Static Electrical Characteristics (continued)

Characteristics noted under conditions $4.5\text{ V} \leq V_{DD} \leq 5.5\text{ V}$, $6.0\text{ V} \leq V_{PWR} \leq 27\text{ V}$, $-40\text{ }^\circ\text{C} \leq T_A \leq 125\text{ }^\circ\text{C}$, unless otherwise noted. Typical values noted reflect the approximate parameter mean at $T_A = 25\text{ }^\circ\text{C}$ under nominal conditions, unless otherwise noted.

Symbol	Characteristic	Min	Typ	Max	Unit	Notes
Control Interface						
V_{IH}	Input Logic High-voltage	$0.7 \times V_{DD}$	–	–	V	(15)
V_{IL}	Input Logic Low-voltage	–	–	$0.2 \times V_{DD}$	V	(15)
$V_{IN[0:1](HYS)}$	Input Logic Voltage Hysteresis	100	600	1200	mV	(16)
I_{DWN}	Input Logic Pull-down Current (SCLK, IN, SI)	5.0	–	20	μA	
$V_{\overline{RST}}$	\overline{RST} Input Voltage Range	4.5	5.0	5.5	V	
C_{SO}	SO, \overline{FS} Tri-state Capacitance	–	–	20	pF	(17)
R_{DWN}	Input Logic Pull-down Resistor (\overline{RST}) and WAKE	100	200	400	$\text{k}\Omega$	
C_{IN}	Input Capacitance	–	4.0	12	pF	(17)
$V_{CL(WAKE)}$	WAKE Input Clamp Voltage $I_{CL(WAKE)} < 2.5\text{ mA}$	7.0	–	14	V	(18)
$V_{F(WAKE)}$	WAKE Input Forward Voltage $I_{CL(WAKE)} = -2.5\text{ mA}$	-2.0	–	-0.3	V	
V_{SOH}	SO High-state Output Voltage $I_{OH} = 1.0\text{ mA}$	$0.8 \times V_{DD}$	–	–	V	
V_{SOL}	\overline{FS} , SO Low-state Output Voltage $I_{OL} = -1.6\text{ mA}$	–	0.2	0.4	V	
$I_{SO(LEAK)}$	SO Tri-state Leakage Current $\overline{CS} > 0.7 V_{DD}$	-5.0	0.0	5.0	μA	
I_{UP}	Input Logic Pull-up Current \overline{CS} , $V_{IN[0:1]} > 0.7 \times V_{DD}$	5.0	–	20	μA	(19)
RFS RFS _{DIS} RFS _{OFFOFF} RFS _{ONOFF} RFS _{ONON}	FSI Input Pin External Pull-down Resistance FSI Disabled, HS[0:1] Indeterminate FSI Enabled, HS[0:1] OFF FSI Enabled, HS0 ON, HS1 OFF FSI Enabled, HS[0:1] ON	– 6.0 15 40	0.0 6.5 17 Infinite	1.0 7.0 19 –	$\text{k}\Omega$	

Notes

15. Upper and lower logic threshold voltage range applies to SI, \overline{CS} , SCLK, \overline{RST} , IN[0:1], and WAKE input signals. The WAKE and \overline{RST} signals may be supplied by a derived voltage reference to V_{PWR} .
16. No hysteresis on FSI and WAKE pins. Parameter is guaranteed by processing monitoring but is not production tested.
17. Input capacitance of SI, CS, SCLK, \overline{RST} , and WAKE. This parameter is guaranteed by process monitoring but is not production tested.
18. The current must be limited by a series resistance when using voltages $> 7.0\text{ V}$.
19. Pull-up current is with \overline{CS} Open. \overline{CS} has an active internal pull-up to V_{DD} .

DYNAMIC ELECTRICAL CHARACTERISTICS

Table 5. Dynamic Electrical Characteristics

Characteristics noted under conditions $4.5\text{ V} \leq V_{DD} \leq 5.5\text{ V}$, $6.0\text{ V} \leq V_{PWR} \leq 27\text{ V}$, $-40\text{ }^\circ\text{C} \leq T_A \leq 125\text{ }^\circ\text{C}$, unless otherwise noted. Typical values noted reflect the approximate parameter mean at $T_A = 25\text{ }^\circ\text{C}$ under nominal conditions, unless otherwise noted.

Symbol	Characteristic	Min	Typ	Max	Unit	Notes
POWER OUTPUT TIMING						
SR _{RA_SLOW}	Output Rising Slow Slew Rate A (DICR D3 = 0) 9.0 V < V _{PWR} < 16 V	0.15	0.5	1.0	V/μs	(20)
SR _{RB_SLOW}	Output Rising Slow Slew Rate B (DICR D3 = 0) 9.0 V < V _{PWR} < 16 V	0.06	0.2	0.6	V/μs	(21)
SR _{RA_FAST}	Output Rising Fast Slew Rate A (DICR D3 = 1) 9.0 V < V _{PWR} < 16 V	0.3	0.8	3.2	V/μs	(20)
SR _{RB_FAST}	Output Rising Fast Slew Rate B (DICR D3 = 1) 9.0 V < V _{PWR} < 16 V	0.06	0.2	2.4	V/μs	(21)
SR _{FA_SLOW}	Output Falling Slow Slew Rate A (DICR D3 = 0) 9.0 V < V _{PWR} < 16 V	0.15	0.5	1.0	V/μs	(20)
SR _{FB_SLOW}	Output Falling Slow Slew Rate B (DICR D3 = 0) 9.0 V < V _{PWR} < 16 V	0.06	0.2	0.6	V/μs	(21)
SR _{FA_FAST}	Output Falling Fast Slew Rate A (DICR D3 = 1) 9.0 V < V _{PWR} < 16 V	0.6	1.6	3.2	V/μs	(20)
SR _{FB_FAST}	Output Falling Fast Slew Rate B (DICR D3 = 1) 9.0 V < V _{PWR} < 16 V	0.2	0.7	2.4	V/μs	(21)
t _{DLY(ON)}	Output Turn-ON Delay Time in Fast/Slow Slew Rate DICR = 0, DICR = 1	0.5	18	100	μs	(22)
t _{DLY_SLOW(OFF)}	Output Turn-OFF Delay Time in Slow Slew Rate Mode DICR = 0	10	115	250	μs	(23)
t _{DLY_FAST(OFF)}	Output Turn-OFF Delay Time in Fast Slew Rate Mode DICR = 1	1.0	30	100	μs	(23)
f _{PWM}	Direct Input Switching Frequency (DICR D3 = 0)	–	300	–	Hz	
t _{OCL0}	Overcurrent Detection Blanking Time (OCLT[1:0])	00	155	202	ms	
t _{OCL1}		01	7.0	13		
t _{OCL2}		10	0.8	1.6		
t _{OCL3}		11	0.08	0.25		
t _{OCH}	Overcurrent High Detection Blanking Time	1.0	10	20	μs	
t _{CNS_VAL}	CS to CSNS Valid Time	–	–	10	μs	(24)

Notes

20. Rise and Fall Slew Rates A measured across a 5.0 Ω resistive load at high-side output = 0.5 V to V_{PWR} - 3.5 V. These parameters are guaranteed by process monitoring.
21. Rise and Fall Slew Rates B measured across a 5.0 Ω resistive load at high-side output = V_{PWR} - 3.5 V to V_{PWR} - 0.5 V. These parameters are guaranteed by process monitoring.
22. Turn-ON delay time measured from rising edge of IN[0:1] signal that would turn the output ON to V_{HS[0:1]} = 0.5 V with R_L = 5.0 Ω resistive load.
23. Turn-OFF delay time measured from falling edge that would turn the output OFF to V_{HS[0:1]} = V_{PWR} - 0.5 V with R_L = 5.0 Ω resistive load.
24. Time necessary for the CSNS to be within ±5% of the targeted value.

Table 5. Dynamic Electrical Characteristics (continued)

Characteristics noted under conditions $4.5\text{ V} \leq V_{DD} \leq 5.5\text{ V}$, $6.0\text{ V} \leq V_{PWR} \leq 27\text{ V}$, $-40\text{ }^\circ\text{C} \leq T_A \leq 125\text{ }^\circ\text{C}$, unless otherwise noted. Typical values noted reflect the approximate parameter mean at $T_A = 25\text{ }^\circ\text{C}$ under nominal conditions, unless otherwise noted.

Symbol	Characteristic	Min	Typ	Max	Unit	Notes
POWER OUTPUT TIMING (CONTINUED)						
t_{OSD0}	HS1 Switching Delay Time (OSD[2:0]) 000	–	0	–		
t_{OSD1}	001	55	75	95		
t_{OSD2}	010	110	150	190		
t_{OSD3}	011	165	225	285	ms	
t_{OSD4}	100	220	300	380		
t_{OSD5}	101	275	375	475		
t_{OSD6}	110	330	450	570		
t_{OSD7}	111	385	525	665		
t_{OSD0}	HS0 Switching Delay Time (OSD[2:0]) 000	–	0	–		
t_{OSD1}	001	–	0	–		
t_{OSD2}	010	110	150	190		
t_{OSD3}	011	110	150	190	ms	
t_{OSD4}	100	220	300	380		
t_{OSD5}	101	220	300	380		
t_{OSD6}	110	330	450	570		
t_{OSD7}	111	330	450	570		
t_{WDTO0}	Watchdog Timeout (WD[1:0]) 00	434	620	806		
t_{WDTO1}	01	207	310	403	ms	(25)
t_{WDTO2}	10	1750	2500	3250		
t_{WDTO3}	11	875	1250	1625		

SPI INTERFACE CHARACTERISTICS

f_{SPI}	Recommended Frequency of SPI Operation	–	–	3.0	MHz	
t_{WRST}	Required Low State Duration for \overline{RST}	–	50	350	ns	(26)
t_{CS}	Rising Edge of \overline{CS} to Falling Edge of \overline{CS} (Required Setup Time)	–	–	300	ns	(27)
t_{ENBL}	Rising Edge of \overline{RST} to Falling Edge of \overline{CS} (Required Setup Time)	–	–	5.0	μs	(27)
t_{LEAD}	Falling Edge of \overline{CS} to Rising Edge of SCLK (Required Setup Time)	–	50	167	ns	(27)
t_{WSCLKh}	Required High State Duration of SCLK (Required Setup Time)	–	–	167	ns	(27)
t_{WSCLKl}	Required Low State Duration of SCLK (Required Setup Time)	–	–	167	ns	(27)
t_{LAG}	Falling Edge of SCLK to Rising Edge of \overline{CS} (Required Setup Time)	–	50	167	ns	(27)
$t_{SI(SU)}$	SI to Falling Edge of SCLK (Required Setup Time)	–	25	83	ns	(28)
$t_{SI(HOLD)}$	Falling Edge of SCLK to SI (Required Setup Time)	–	25	83	ns	(28)
t_{RSO}	SO Rise Time $C_L = 200\text{ pF}$	–	25	50	ns	
t_{FSO}	SO Fall Time $C_L = 200\text{ pF}$	–	25	50	ns	
t_{RSI}	SI, \overline{CS} , SCLK, Incoming Signal Rise Time	–	–	50	ns	(28)
t_{RSI}	SI, \overline{CS} , SCLK, Incoming Signal Fall Time	–	–	50	ns	(28)

Notes

25. Watchdog timeout delay measured from the rising edge of WAKE to \overline{RST} from a sleep-state condition to output turn-ON with the output driven OFF and FSI floating. The values shown are for WDR setting of [00]. The accuracy of t_{WDTO} is consistent for all configured watchdog timeouts.
26. \overline{RST} low duration measured with outputs enabled and going to OFF or disabled condition.
27. Maximum setup time required for the 34984 is the minimum guaranteed time needed from the microcontroller.
28. Rise and Fall time of incoming SI, \overline{CS} , and SCLK signals suggested for design consideration to prevent the occurrence of double pulsing.

Table 5. Dynamic Electrical Characteristics (continued)

Characteristics noted under conditions $4.5\text{ V} \leq V_{DD} \leq 5.5\text{ V}$, $6.0\text{ V} \leq V_{PWR} \leq 27\text{ V}$, $-40\text{ }^\circ\text{C} \leq T_A \leq 125\text{ }^\circ\text{C}$, unless otherwise noted. Typical values noted reflect the approximate parameter mean at $T_A = 25\text{ }^\circ\text{C}$ under nominal conditions, unless otherwise noted.

Symbol	Characteristic	Min	Typ	Max	Unit	Notes
SPI INTERFACE CHARACTERISTICS (CONTINUED)						
$t_{SO(EN)}$	Time from Falling Edge of \overline{CS} to SO Low-impedance	–	–	145	ns	(29)
$t_{SO(DIS)}$	Time from Rising Edge of \overline{CS} to SO High-impedance	–	65	145	ns	(30)
t_{VALID}	Time from Rising Edge of SCLK to SO Data Valid $0.2 \times V_{DD} \leq SO \leq 0.8 \times V_{DD}$, $C_L = 200\text{ pF}$	–	65	105	ns	(31)

Notes

29. Time required for output status data to be available for use at SO. $1.0\text{ k}\Omega$ on pull-up on \overline{CS} .
 30. Time required for output status data to be terminated at SO. $1.0\text{ k}\Omega$ on pull-up on \overline{CS} .
 31. Time required to obtain valid data out from SO following the rise of SCLK.

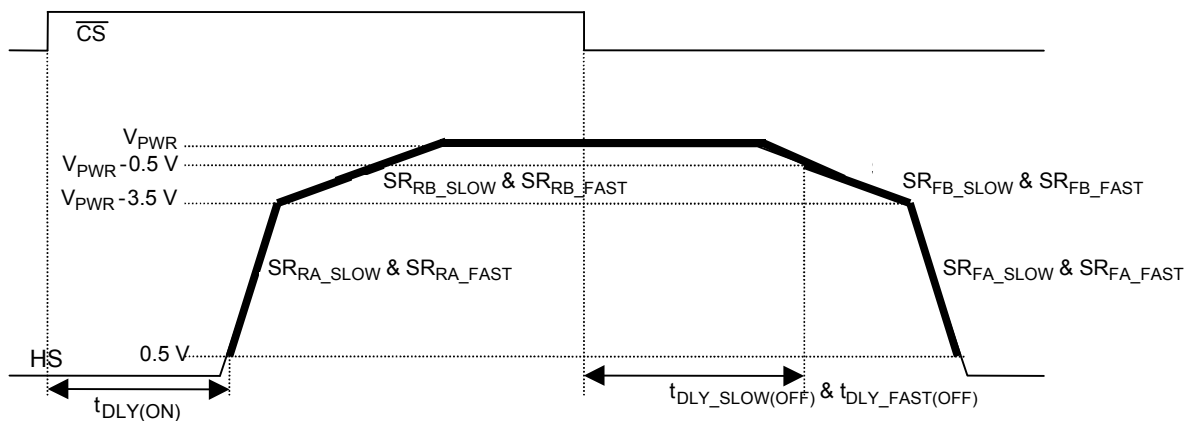
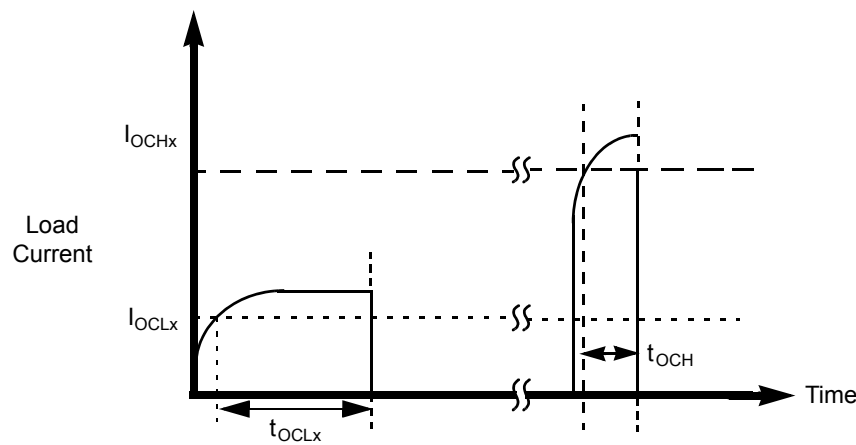
TIMING DIAGRAMS

Figure 4. Output Slew Rate and Time Delays

Figure 5. Overcurrent Shutdown

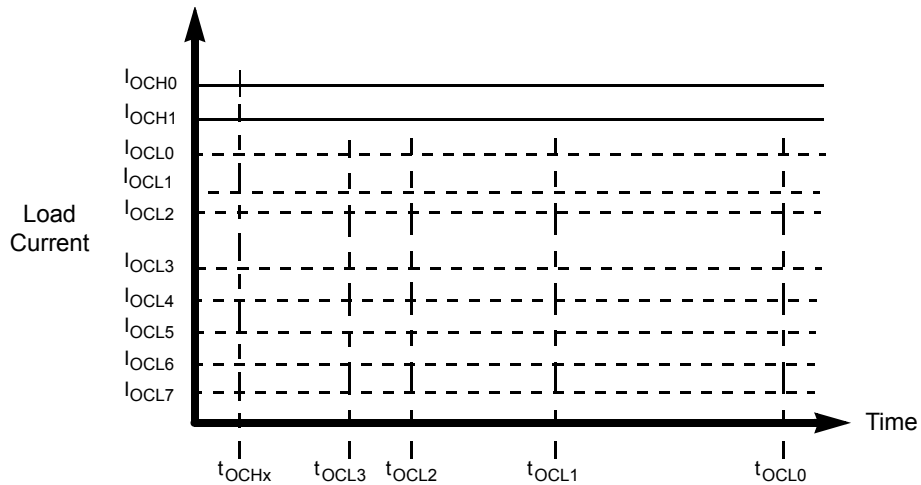

Figure 6. Overcurrent Low and High Detection

Figure 6 illustrates the overcurrent detection level (loclx, lochx) the device can reach for each overcurrent detection blanking time (tochx, toclx):

- During tochx, the device can reach up to loch0 overcurrent level.
- During tocl3 or tocl2 or tocl1 or tocl0, the device can be programmed to detect up to locl0.

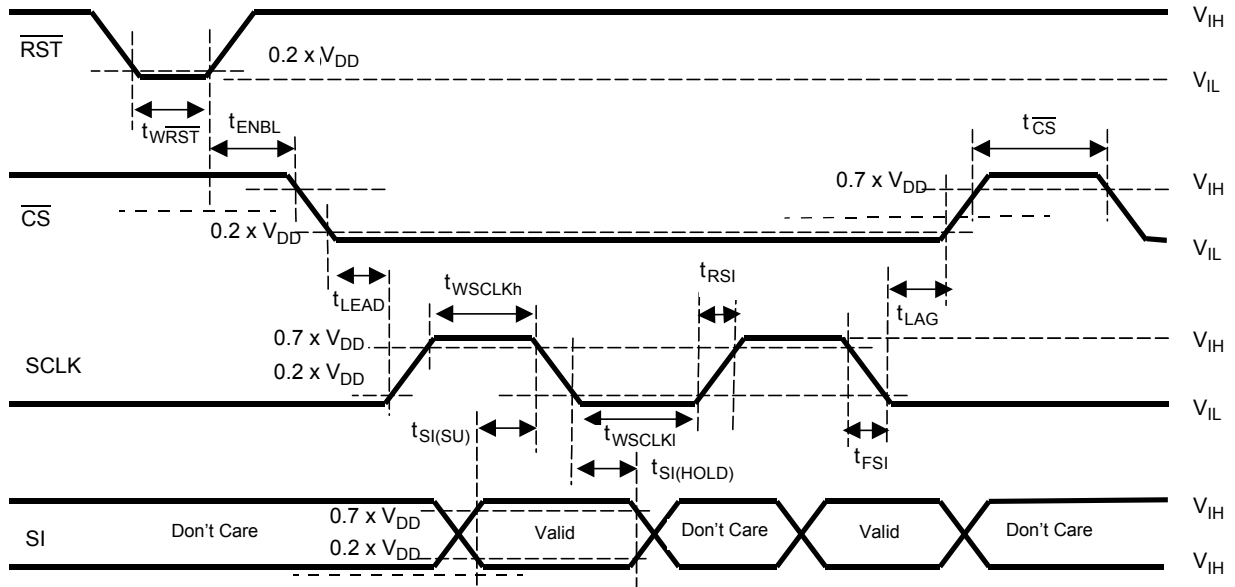

Figure 7. Input Timing Switching Characteristics

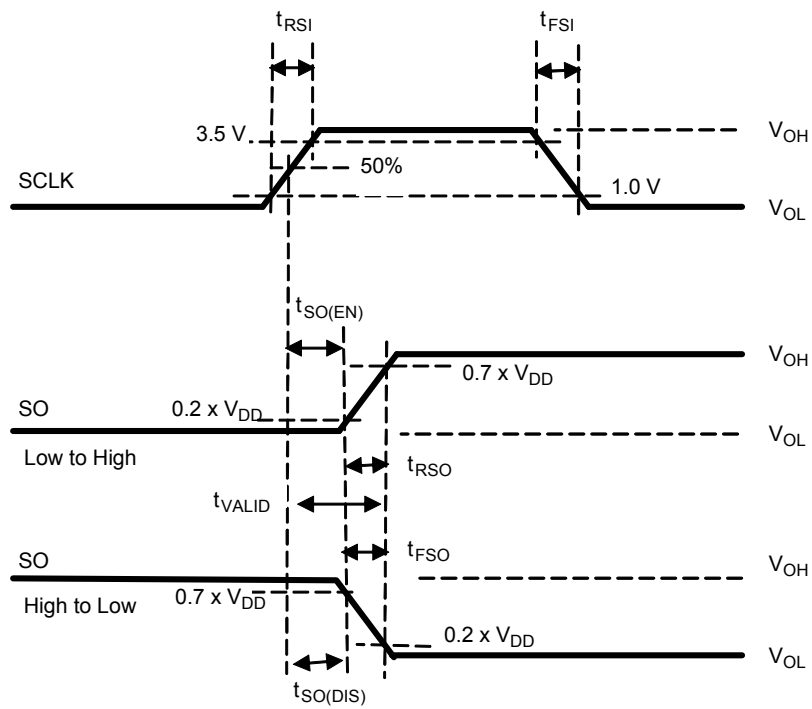

Figure 8. SCLK Waveform and Valid SO Data Delay Time

FUNCTIONAL DESCRIPTION

INTRODUCTION

The 34984 is a dual self-protected 4.0 mΩ silicon switch used to replace electromechanical relays, fuses, and discrete devices in power management applications. The 34984 is designed for harsh environments, and it includes self-recovery features. The device is suitable for loads with high inrush current, as well as motors and all types of resistive and inductive loads.

Programming, control, and diagnostics are implemented via the serial peripheral interface (SPI). A dedicated parallel input is available for alternate and pulse width modulation (PWM) control of each output. SPI-programmable fault trip thresholds allow the device to be adjusted for optimal performance in the application.

The 34984 is packaged in a power-enhanced 12 x 12 nonleaded PQFN package with exposed tabs.

FUNCTIONAL PIN DESCRIPTION

OUTPUT CURRENT MONITORING (CSNS)

This pin is used to output a current proportional to the designated HS0-1 output. That current is fed into a ground-referenced resistor and its voltage is monitored by an MCU's A/D. The channel to be monitored is selected via the SPI. This pin can be tri-stated through the SPI.

WAKE (WAKE)

This pin is used to input a Logic [1] signal so as to enable the watchdog timer function. An internal clamp protects this pin from high damaging voltages when the output is current limited with an external resistor. This input has a passive internal pull-down.

RESET ($\overline{\text{RST}}$)

This input pin is used to initialize the device configuration and fault registers, as well as place the device in a low-current Sleep mode. The pin also starts the watchdog timer when transitioning from Logic Low to Logic High. This pin should not be allowed to be Logic High until V_{DD} is in regulation. This pin has a passive internal pull-down.

DIRECT IN 0 & 1 (INx)

This input pin is used to directly control the output HS0 and 1. This input has an active internal pull-down current source and requires CMOS logic levels. This input may be configured via the SPI.

FAULT STATUS ($\overline{\text{FS}}$)

This is an open drain configured output requiring an external pull-up resistor to V_{DD} for fault reporting. When a device fault condition is detected, this pin is active Low. Specific device diagnostic faults are reported via the SPI SO pin.

FAIL-SAFE INPUT (FSI)

The value of the resistance connected between this pin and ground determines the state of the outputs after a watchdog timeout occurs. Depending on the resistance value, either all outputs are OFF, ON, or the output HS0 only is ON. When the FSI pin is connected to GND, the watchdog circuit and Fail-safe operation are disabled. This pin incorporates an active internal pull-up current source.

CHIP SELECT ($\overline{\text{CS}}$)

This input pin is connected to a chip select output of a master microcontroller (MCU). The MCU determines which device is addressed (selected) to receive data by pulling the CS pin of the selected device Logic Low, enabling SPI communication with the device. Other *unselected* devices on the serial link having their $\overline{\text{CS}}$ pins pulled-up Logic High disregard the SPI communication data sent. This pin incorporates an active internal pull-up current source.

SERIAL CLOCK (SCLK)

This input pin is connected to the MCU providing the required bit shift clock for SPI communication. It transitions one time per bit transferred at an operating frequency, f_{SPI} , defined by the communication interface. The 50 percent duty cycle CMOS-level serial clock signal is idle between command transfers. The signal is used to shift data into and out of the device. This input has an active internal pull-down current source.

SERIAL INPUT (SI)

This is a command data input pin connected to the SPI Serial Data Output of the MCU or to the SO pin of the previous device of a daisy chain of devices. The input requires CMOS logic-level signals and incorporates an active internal pull-down current source. Device control is facilitated by the input's receiving the MSB first of a serial 8-bit control command. The MCU ensures data is available upon the falling edge of SCLK. The logic state of SI present upon the rising edge of SCLK loads that bit command into the internal command shift register.

DIGITAL DRAIN VOLTAGE (VDD)

This is an external voltage input pin used to supply power to the SPI circuit. In the event V_{DD} is lost, an internal supply provides power to a portion of the logic, ensuring limited functionality of the device. All device configuration registers are reset.

SERIAL OUTPUT (SO)

This output pin is connected to the SPI Serial Data Input pin of the MCU or to the SI pin of the next device of a daisy chain of devices. This output will remain tri-stated (high-impedance OFF condition) so long as the \overline{CS} pin of the device is Logic High. SO is only active when the \overline{CS} pin of the device is asserted Logic Low. The generated SO output signals are CMOS logic levels. SO output data is available on the falling edge of SCLK and transitions immediately on the rising edge of SCLK.

POSITIVE POWER SUPPLY (VPWR)

This pin connects to the positive power supply and is the source input of operational power for the device. The VPWR pin is a backside surface mount tab of the package.

HIGH-SIDE OUTPUT 0 & 1 (HSx)

This pin protects 4.0 m Ω high-side power output to the load.

FUNCTIONAL INTERNAL BLOCK DESCRIPTION

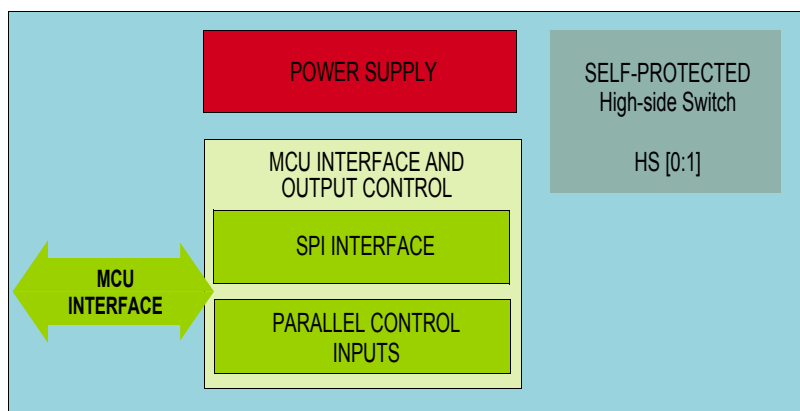

POWER SUPPLY

The 34984 is designed to operate from 4.0 V to 28 V on the VPWR pin. Characteristics are provided from 6.0 V to 20 V for the device. The VPWR pin supplies power to internal regulator, analog, and logic circuit blocks. The V_{DD} supply is used for serial peripheral interface (SPI) communication in order to configure and diagnose the device. This IC architecture provides a low quiescent current sleep mode. Applying V_{PWR} and V_{DD} to the device will place the device in the Normal mode. The device will transit to Fail-safe mode in case of failures on the SPI (watchdog timeout).

HIGH-SIDE SWITCH: HS[0:1]

Those pins are the high-side outputs controlling multiple loads with high inrush current, as well as motors and all types of resistive and inductive loads. This N-channel MOSFET with 4.0 mΩ R_{DS(on)}, is self-protected and each N-channel presents extended diagnostics in order to detect load disconnections and short-circuit fault conditions. The HS[0:1] outputs are actively clamped during a turn-off of inductive loads.

MCU INTERFACE AND OUTPUT CONTROL

In Normal mode, the loads are controlled directly from the MCU through the SPI. With a dedicated SPI command, it is possible to independently turn on and off several loads that are PWMed at the same frequency, and duty cycles with only one PWM signal. An analog feedback output provides a current proportional to each load current. The SPI is used to configure and to read the diagnostic status (faults) of the high-side output. The reported fault conditions are: open load, short-circuit to ground (OCLO-resistive and OCHI-severe short-circuit), thermal shutdown, and under/overvoltage.

In Fail-safe mode, the loads are controlled with dedicated parallel input pins. The device is configured in default mode.

FUNCTIONAL DEVICE OPERATION

OPERATIONAL MODES

The 34984 has four operating modes: Sleep, Normal, Fault, and Fail-safe. [Table 6](#) summarizes details contained in succeeding paragraphs.

Table 6. Fail-safe Operation and Transitions to Other 34984 Modes

Mode	$\overline{\text{FS}}$	WAKE	RST	WDT O	Comments
Sleep	x	0	0	x	Device is in Sleep mode. All outputs are OFF.
Normal	1	x	1	No	Normal mode. Watchdog is active if enabled.
Fault	0	1	x	No	The device is currently in Fault mode. The faulted output(s) is (are) OFF.
	0	x	1		
Fail-safe	1	0	1	Yes	Watchdog has timed out and the device is in Fail-safe mode. The outputs are as configured with the RFS resistor connected to FSI. RST and WAKE must be transitioned to Logic [0] simultaneously to bring the device out of the Fail-safe mode or momentarily tied the FSI pin to ground.
	1	1	1		
	1	1	0		

x = Don't care.

SLEEP MODE

The default mode of the 34984 is the Sleep mode. This is the state of the device after first applying power voltage (V_{PWR}), prior to any I/O transitions. This is also the state of the device when the WAKE and $\overline{\text{RST}}$ are both Logic [0]. In the Sleep mode, the output and all unused internal circuitry, such as the internal 5.0 V regulator, are off to minimize current draw. In addition, all SPI-configurable features of the device are as if set to Logic [0]. The device will transition to the Normal or Fail-safe operating modes based on the WAKE and RST inputs as defined in [Table 6](#).

NORMAL MODE

The 34984 is in Normal mode when:

- V_{PWR} is within the normal voltage range.
- $\overline{\text{RST}}$ pin is Logic [1].
- No fault has occurred.

FAIL-SAFE AND WATCHDOG

If the FSI input is not grounded, the watchdog timeout detection is active when either the WAKE or $\overline{\text{RST}}$ input pin transitions from Logic [0] to Logic [1]. The WAKE input is capable of being pulled up to V_{PWR} with a series of limiting resistance that limits the internal clamp current according to the specification.

The watchdog timeout is a multiple of an internal oscillator and is specified in [Table 15](#). As long as the WD bit (D7) of an incoming SPI message is toggled within the minimum watchdog timeout period (WDTO), based on the programmed value of the WDR the device will operate normally. If an internal watchdog timeout occurs before the WD bit, the device will revert to a Fail-safe mode until the device is reinitialized.

During the Fail-safe mode, the outputs will be ON or OFF depending upon the resistor RFS connected to the FSI pin, regardless of the state of the various direct inputs and modes ([Table 7](#)). In this mode, the SPI register content is retained except for overcurrent high and low detection levels and timing, which are reset to their default value (SOCL, SOCH, and OCLT). Then the watchdog, overvoltage, overtemperature, and overcurrent circuitry (with default value) are fully operational.

Table 7. Output State During Fail-safe Mode

RFS (k Ω)	High-side State
0	Fail-safe mode Disabled
6.0	Both HS0 and HS1 OFF
15	HS0 ON, HS1 OFF
30	Both HS0 and HS1 ON

The Fail-safe mode can be detected by monitoring the WDTO bit D2 of the WD register. This bit is Logic [1] when the device is in Fail-safe mode. The device can be brought out of the Fail-safe mode by transitioning the WAKE and $\overline{\text{RST}}$ pins from Logic [1] to Logic [0] or forcing the FSI pin to Logic [0]. [Table 6](#) summarizes the various methods for resetting the device from the latched Fail-safe mode.

If the FSI pin is tied to GND, the watchdog Fail-safe operation is disabled.

LOSS OF V_{DD}

If the external 5.0 V supply is not within specification, or even disconnected, all register content is reset. The two outputs can still be driven by the direct inputs IN1:IN0. The 34984 uses the supply input to power the output MOSFET related current sense circuitry and any other internal logic providing Fail-safe device operation with no V_{DD} supplied. In this state, the watchdog, overvoltage, overtemperature, and overcurrent circuitry are fully operational with default values.

FAULT MODE

The 34984 indicates the following faults as they occur by driving the $\overline{\text{FS}}$ pin to Logic [0]:

- Overtemperature fault
- Open load fault
- Overcurrent fault (high and low)
- Overvoltage and undervoltage fault

The $\overline{\text{FS}}$ pin will automatically return to Logic [1] when the fault condition is removed, except for overcurrent and in some cases undervoltage.

Fault information is retained in the fault register and is available (and reset) via the SO pin during the first valid SPI communication (refer to [Table 17](#)).

PROTECTION AND DIAGNOSIS FEATURES

OVERTEMPERATURE FAULT (NON-LATCHING)

The 34984 incorporates overtemperature detection and shutdown circuitry in each output structure. Overtemperature detection is enabled when an output is in the ON state.

For the output, an overtemperature fault (OTF) condition results in the faulted output turning OFF until the temperature falls below the $T_{SD(HYS)}$. This cycle will continue indefinitely until action is taken by the MCU to shut OFF the output, or until the offending load is removed. When experiencing this fault, the OTF fault bit will be set in the status register and cleared after either a valid SPI read or a power reset of the device.

OVERVOLTAGE FAULT (NON-LATCHING)

The 34984 shuts down the output during an overvoltage fault (OVF) condition on the VPWR pin. The output remains in the OFF state until the overvoltage condition is removed. When experiencing this fault, the OVF fault bit is set in the bit OD1 and cleared after either a valid SPI read or a power reset of the device.

The overvoltage protection and diagnostic can be disabled through the SPI (bit OV_dis).

UNDERVOLTAGE SHUTDOWN (LATCHING OR NON-LATCHING)

The output(s) will latch off at some supply voltage below 6.0 V. As long as the V_{DD} level stays within the normal specified range, the internal logic states within the device will be sustained.

In the case where supply voltage drops below the undervoltage threshold (VPWRUV) output will turn off, $\overline{\text{FS}}$ will go to Logic [0], and the fault register UVF bit will be set to 1.

Two cases need to be considered when the supply level recovers:

- If output(s) command is (are) low, $\overline{\text{FS}}$ will go to Logic [1] but the UVF bit will remain set to 1 until the next read operation.
- If the output command is ON, then $\overline{\text{FS}}$ will remain at Logic [0]. The output must be turned OFF and ON again to re-enable the state of output and release $\overline{\text{FS}}$. The UVF bit will remain set to 1 until the next read operation.

The undervoltage protection can be disabled through the SPI (bit UV_dis = 1). In this case, the $\overline{\text{FS}}$ and UVF bits do not report any undervoltage fault condition and the output state will not be changed as long as supply voltage does not drop any lower than 2.5 V.

OPEN LOAD FAULT (NON-LATCHING)

The 34984 incorporates open load detection circuitry on each output. Output open load fault (OLF) is detected and reported as a fault condition when that output is disabled (OFF). The open load fault is detected and latched into the status register after the internal gate voltage is pulled low enough to turn OFF the output. The OLF fault bit is set in the status register. If the open load fault is removed, the status register will be cleared after reading the register.

The open load protection can be disabled through SPI (bit OL_dis). It is recommended to disable the open load detection circuitry (OL_dis bit sets to logic [1]) in case of permanent open load fault condition.

OVERCURRENT FAULT (LATCHING)

The device has eight programmable overcurrent low detection levels (I_{OCL}) and two programmable overcurrent high detection levels (I_{OCH}) for maximum device protection. The two selectable, simultaneously active overcurrent detection levels, defined by I_{OCH} and I_{OCL} , are illustrated in [Figure 6](#). The eight different overcurrent low detect levels ($I_{OCL0}:I_{OCL7}$) are likewise illustrated in [Figure 6](#).

If the load current level ever reaches the selected overcurrent low detect level and the overcurrent condition exceeds the programmed overcurrent time period (t_{OCx}), the device will latch the effected output OFF.

If at any time the current reaches the selected I_{OCH} level, then the device will immediately latch the fault and turn OFF the output, regardless of the selected t_{OCL} driver. For both cases, the device output will stay off indefinitely until the device is commanded OFF and then ON again.

REVERSE VOLTAGE

The output survives the application of reverse voltage as low as -16 V. Under these conditions, the output's gates are enhanced to keep the junction temperature less than 150 °C. The ON resistance of the output is fairly similar to that in the Normal mode. No additional passive components are required. If one or more of the outputs is driving a DC motor with an external freewheeling diode in parallel to the load, a direct current passes through this diode and the internal high-side switch, in cases of reverse voltage.

As [Figure 9](#) shows, it is essential to protect this power line. The proposed solution is an external N-channel low-side with its gate tied to supply voltage through a resistor.

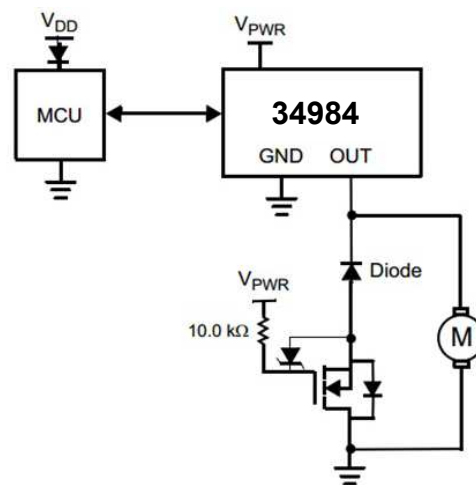

Figure 9. Reverse Voltage Protection

GROUND DISCONNECT PROTECTION

In the event the 34984 ground is disconnected from load ground, the device protects itself and safely turns OFF the output regardless the state of the output at the time of disconnection. A 10 k resistor needs to be added between the wake pin and the rest of the circuitry in order to ensure that the device turns off in case of ground disconnect, and to prevent this pin from exceeding its maximum ratings

Table 8. Device Behavior in Case of Undervoltage

High-side Switch (VPWR Voltage)**	State	UV Enable IN = 0 (Falling VPWR)	UV Enable IN = 0 (Rising VPWR)	UV Enable IN*** = 1 (Falling VPWR)	UV Enable IN*** = 1 (Rising VPWR)	UV Disable IN = 0 (Falling or Rising VPWR)	UV Disable IN*** = 1 (Falling or Rising VPWR)
VPWR > VPWRUV	Output State	OFF	OFF	ON	OFF	OFF	ON
	\overline{FS} State	1	1	1	0	1	1
	SPI Fault Register UVF Bit	0	1 until next read	0	1	0	0
VPWRUV > VPWR > UVPOR	Output State	OFF	OFF	OFF	OFF	OFF	ON
	\overline{FS} State	0	0	0	0	1	1
	SPI Fault Register UVF Bit	1	1	1	1	0	0

Table 8. Device Behavior in Case of Undervoltage

High-side Switch (VPWR Voltage)**	State	UV Enable IN = 0 (Falling VPWR)	UV Enable IN = 0 (Rising VPWR)	UV Enable IN*** = 1 (Falling VPWR)	UV Enable IN*** = 1 (Rising VPWR)	UV Disable IN = 0 (Falling or Rising VPWR)	UV Disable IN*** = 1 (Falling or Rising VPWR)
UVPOR > VPWR > 2.5 V*	Output State	OFF	OFF	OFF	OFF	OFF	ON
	\overline{FS} State	1	1	1	1	1	1
	SPI Fault Register UVF Bit	1 until next read	1	1 until next read	1 until next read	0	0
2.5 V > VPWR > 0 V	Output State	OFF	OFF	OFF	OFF	OFF	OFF
	\overline{FS} State	1	1	1	1	1	1
	SPI Fault Register UVF Bit	1 until next read	1 until next read	1 until next read	1 until next read	0	0
	Comments	UV fault is not latched	UV fault is not latched		UV fault is latched		

* Typical value; not guaranteed

** While VDD remains within specified range.

*** = IN is equivalent to IN direct input or IN_spi SPI input.

LOGIC COMMANDS AND REGISTERS

SPI PROTOCOL DESCRIPTION

The SPI interface has a full duplex, three-wire synchronous data transfer with four I/O lines associated with it: Serial Clock (SCLK), Serial Input (SI), Serial Output (SO), and Chip Select (CS).

The SI/SO pins of the 34984 follow a first-in first-out (D7/D0) protocol with both input and output words transferring the most significant bit (MSB) first. All inputs are compatible with 5.0 V CMOS logic levels.

The SPI lines perform the following functions:

SERIAL CLOCK (SCLK)

Serial clocks (SCLK) the internal shift registers of the 34984 device. The serial input (SI) pin accepts data into the input shift register on the falling edge of the SCLK signal while the serial output (SO) pin shifts data information out of the SO line driver on the rising edge of the SCLK signal. It is important that the SCLK pin be in a logic low state whenever CS makes any transition. For this reason, it is recommended that the SCLK pin be in a Logic [0] state whenever the device is not accessed (CS Logic [1] state). SCLK has an active internal pull-down, I_{DWN} . When CS is Logic [1], signals at the SCLK and SI pins are ignored and SO is tri-stated (high-impedance). See [Figure 10](#) and [Figure 11](#).

SERIAL INPUT (SI)

This is a serial interface (SI) command data input pin. SI instruction is read on the falling edge of SCLK. An 8-bit stream of serial data is required on the SI pin, starting with D7 to D0. The internal registers of the 34984 are configured and controlled using a 4-bit addressing scheme, as shown in [Table 9](#). Register addressing and configuration are described in [Table 10](#). The SI input has an active internal pull-down, I_{DWN} .

SERIAL OUTPUT (SO)

The SO data pin is a tri-stateable output from the shift register. The SO pin remains in a high-impedance state until the \overline{CS} pin is put into a Logic [0] state. The SO data is capable of reporting the status of the output, the device configuration, and the state of the key inputs. The SO pin changes states on the rising edge of SCLK and reads out on the falling edge of SCLK. Fault and Input Status descriptions are provided in [Table 6](#).

CHIP SELECT (\overline{CS})

The \overline{CS} pin enables communication with the master microcontroller (MCU). When this pin is in a Logic [0] state, the device is capable of transferring information to, and receiving information from, the MCU. The 34984 device latches in data from the Input shift registers to the addressed registers on the rising edge of \overline{CS} . The device transfers status information from the power output to the shift register on the falling edge of \overline{CS} . The SO output driver is enabled when \overline{CS} is Logic [0]. \overline{CS} should transition from a Logic [1] to a Logic [0] state only when SCLK is a Logic [0]. \overline{CS} has an active internal pull-up, I_{UP} .

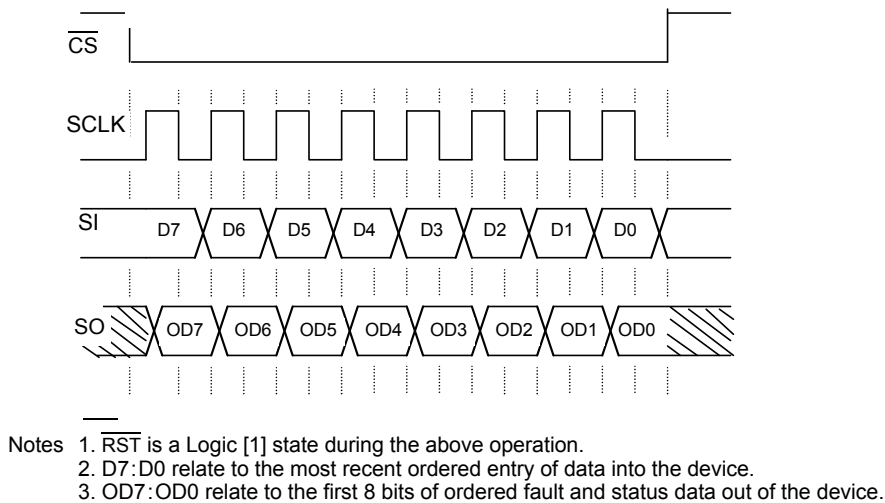

Figure 10. Single 8-Bit Word SPI Communication

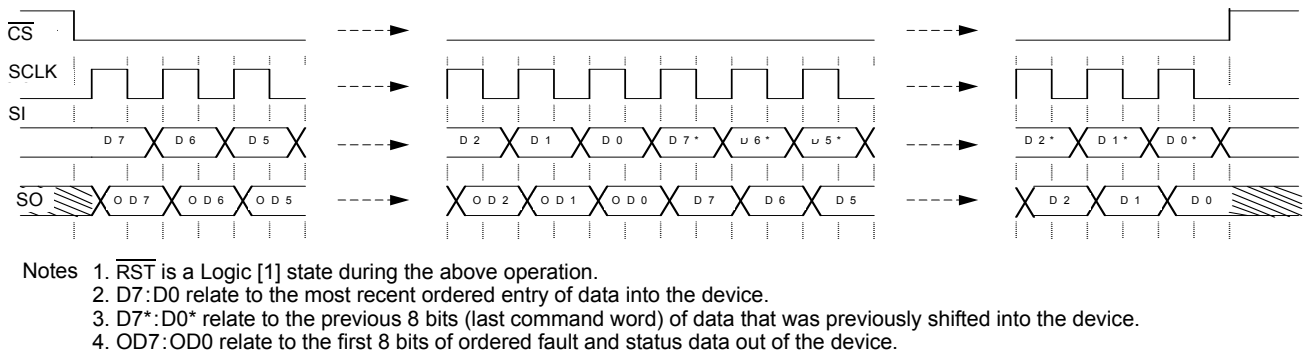

Figure 11. Multiple 8-Bit Word SPI Communication

SERIAL INPUT COMMUNICATION

SPI communication is accomplished using 8-bit messages. A message is transmitted by the MCU starting with the MSB, D7, and ending with the LSB, D0 ([Table 9](#)). Each incoming command message on the SI pin can be interpreted using the following bit assignments: the MSB (D7) is the watchdog bit and in some cases a register address bit common to both outputs or specific to an output; the next three bits, D6:D4, are used to select the command register; and the remaining four bits, D3:D0, are used to configure and control the outputs and their protection features.

Multiple messages can be transmitted in succession to accommodate those applications where daisy chaining is desirable, or to confirm transmitted data, as long as the messages are all multiples of eight bits. Any attempt made to latch in a message that is not eight bits will be ignored.

The 34984 has defined registers, which are used to configure the device and to control the state of the output. [Table 10](#), summarizes the SI registers. The registers are addressed via D6:D4 of the incoming SPI word ([Table 9](#)).

Table 9. SI Message Bit Assignment

Bit Sig	SI Msg Bit	Message Bit Description
MSB	D7	Register address bit for output selection. Also used for watchdog: toggled to satisfy watchdog requirements.
	D6:D4	Register address bits.
	D3:D1	Used to configure the inputs, outputs, and the device protection features and SO status content.
LSB	D0	Used to configure the inputs, outputs, and the device protection features and SO status content.

Table 10. Serial Input Address and Configuration Bit Map

SI Register	Serial Input Data							
	D7	D6	D5	D4	D3	D2	D1	D0
STATR	s	0	0	0	0	SOA2	SOA1	SOA0
OCR	x	0	0	1	CSNS1 $\overline{\text{EN}}$	IN1_SPI	CSNS0 $\overline{\text{EN}}$	IN0_SPI
SOCHLR	s	0	1	0	SOCHs	SOCL2s	SOCL1s	SOCL0s
CDTOLR	s	0	1	1	OL_DIS s	CD_DIS s	OCLT1s	OCLT0s
DICR	s	1	0	0	FAST SR s	CSNS high s	IN DIS s	A/Os
OSDR	0	1	0	1	0	OSD2	OSD1	OSD0
WDR	1	1	0	1	0	0	WD1	WD0
NAR	0	1	1	0	0	0	0	0
UOVR	1	1	1	0	0	0	UV_dis	OV_dis
TEST	x	1	1	1	Freescale Internal Use (Test)			

x = Don't care.

s (SOA3 bit) = Selection of output: Logic [0] = HS0, Logic [1] = HS1.

DEVICE REGISTER ADDRESSING

The following section describes the possible register addresses and their impact on device operation.

Address x000—Status Register (STATR)

The STATR register is used to read the device status and the various configuration register contents without disrupting the device operation or the register contents. The register bits D2:D0, determine the content of the first eight bits of SO data. When register content is specific to one of the two outputs, bit D7 is used to select the desired output (SOA3). In addition to the device status, this feature provides the ability to read the content of the OCR, SOCHLR, CDTOLR, DICR, OSDR, WDR, NAR, and UOVR registers. (Refer to the section entitled [Serial Output Communication \(Device Status Return Data\)](#).)

Address x001—Output Control Register (OCR)

The OCR register allows the MCU to control the outputs through the SPI. Incoming message bit D0 reflects the desired states of the high-side output HS0 (IN0_SPI): a Logic [1] enables the output switch and a Logic [0] turns it OFF. A Logic [1] on message bit D1 enables the Current Sense (CSNS) pin. Similarly, incoming message bit D2 reflects the desired states of the high-side output HS1 (IN1_SPI): Logic [1] enables the output switch and a Logic [0] turns it OFF. A Logic [1] on message bit D3 enables the CSNS pin. In the event that the current sense is enabled for both outputs, the current will be summed. Bit D7 is used to feed the watchdog if enabled.

Address x010— Select Overcurrent High and Low Register (SOCHLR)

The SOCHLR register allows the MCU to configure the output overcurrent low and high detection levels, respectively. Each output is independently selected for configuration based on the state of the D7 bit; a write to this register when D7 is Logic [0] will configure the current detection levels for the HS0. Similarly, if D7 is Logic [1] when this register is written, HS1 is configured. Each output can be configured to different levels. In addition to protecting the device, this slow blow fuse emulation feature can be used to optimize the load requirements matching system characteristics. Bits D2:D0 set the overcurrent low detection level to one of eight possible levels, as shown in [Table 11](#). Bit D3 sets the overcurrent high detection level to one of two levels, which is described in [Table 12](#).

Table 11. Overcurrent Low Detection Levels

SOCL2 (D2)	SOCL1 (D1)	SOCL0 (D0)	Overcurrent Low Detection (Amperes)
0	0	0	25
0	0	1	22.5
0	1	0	20
0	1	1	17.5
1	0	0	15
1	0	1	12.5
1	1	0	10
1	1	1	7.5

Table 12. Overcurrent High Detection Levels

SOCH (D3)	Overcurrent High Detection (Amperes)
0	100
1	75

Address x011—Current Detection Time and Open Load Register (CDTOLR)

The CDTOLR register is used by the MCU to determine the amount of time the device will allow an overcurrent low condition before output latches OFF occurs. Each output is independently selected for configuration based on the state of the D7 bit. A write to this register when bit 7 is Logic [0] will configure the timeout for the HS0. Similarly, if D7 is Logic [1] when this register is written, then HS1 is configured. Bits D1:D0 allow the MCU to select one of four fault blanking times defined in [Table 13](#). Note that these timeouts apply only to the overcurrent low detection levels. If the selected overcurrent high level is reached, the device will latch off within 20 μ s.

Table 13. Overcurrent Low Detection Blanking Time

OCLT[1:0]	Timing
00	155 ms
01	10 ms
10	1.2 ms
11	150 μ s

A Logic [1] on bit D2 disables the overcurrent low (CD_dis) detection timeout feature. A Logic [1] on bit D3 disables the open load (OL) detection feature.

Address x100—Direct Input Control Register (DICR)

The DICR register is used by the MCU to enable, disable, or configure the direct IN pin control of each output. Each output is independently selected for configuration based on the state of bit D7. A write to this register when bit D7 is Logic [0] will configure the direct input control for the HS0. Similarly, if D7 is Logic [1] when this register is written, then HS1 is configured.

A Logic [0] on bit D1 will enable the output for direct control by the IN pin. A Logic [1] on bit D1 will disable the output from direct control. While addressing this register, if the input was enabled for direct control, a Logic [1] for the D0 bit will result in a Boolean AND of the IN pin with its corresponding D0 message bit when addressing the OCR register. Similarly, a Logic [0] on the D0 pin results in a Boolean OR of the IN pin with the corresponding message bits when addressing the OCR register.

The DICR register is useful if there is a need to independently turn on and off several loads that are PWM'd at the same frequency and duty cycle with only one PWM signal. This type of operation can be accomplished by connecting the pertinent direct IN pins of several devices to a PWM output port from the MCU and configuring each of the outputs to be controlled via their respective direct IN pin. The DICR is then used to Boolean AND the direct IN(s) of each of the outputs with the dedicated SPI bit that also controls the output. Each configured SPI bit can now be used to enable and disable the common PWM signal from controlling its assigned output.

A Logic [1] on bit D2 is used to select the high ratio (C_{SR1} , 1/41000) on the CSNS pin for the selected output. The default value [0] is used to select the low ratio (C_{SR0} , 1/20500). A Logic [1] on bit D3 is used to select the high speed slew rate for the selected output. The default value [0] corresponds to the low speed slew rate.