



Chipsmall Limited consists of a professional team with an average of over 10 year of expertise in the distribution of electronic components. Based in Hongkong, we have already established firm and mutual-benefit business relationships with customers from,Europe,America and south Asia,supplying obsolete and hard-to-find components to meet their specific needs.

With the principle of "Quality Parts,Customers Priority,Honest Operation,and Considerate Service",our business mainly focus on the distribution of electronic components. Line cards we deal with include Microchip,ALPS,ROHM,Xilinx,Pulse,ON,Everlight and Freescale. Main products comprise IC,Modules,Potentiometer,IC Socket,Relay,Connector.Our parts cover such applications as commercial,industrial, and automotives areas.

We are looking forward to setting up business relationship with you and hope to provide you with the best service and solution. Let us make a better world for our industry!



## Contact us

Tel: +86-755-8981 8866 Fax: +86-755-8427 6832

Email & Skype: info@chipsmall.com Web: www.chipsmall.com

Address: A1208, Overseas Decoration Building, #122 Zhenhua RD., Futian, Shenzhen, China



## Penta 40 mOhm high-side switch

The 12XS6 is the latest SMARTMOS achievement in automotive lighting drivers. It belongs to an expanding family that helps to control and diagnose incandescent lamps and light-emitting diodes (LEDs) with enhanced precision. It combines flexibility through daisy-chainable SPI 5.0 MHz, extended digital and analog feedbacks, safety and robustness.

Output edge shaping helps to improve electromagnetic performance. To avoid shutting off the device upon inrush current, while still being able to closely track the load current, a dynamic overcurrent threshold profile is featured. Current of each channel can be sensed with a programmable sensing ratio. Whenever communication with the external microcontroller is lost, the device enters a fail operation mode, but remains operational, controllable, and protected.

This new generation of high-side switch products family facilitates ECU design thanks to compatible MCU software and PCB foot print for each device variant. This family is in an end of life vehicles directive compliant package.

### Features

- Penta 40 mΩ high-side switches with high transient current capability
- 16-bit 5.0 MHz SPI control of overcurrent profiles, channel control including PWM duty cycles, output-on and -off open load detections, thermal shutdown and prewarning, and fault reporting
- Output current monitoring with programmable synchronization signal and battery voltage feedback
- Limp home mode
- External smart power switch control
- Operating voltage is 7.0 V to 18 V with sleep current < 5.0 μA, extended mode from 6.0 V to 28 V
- -16 V reverse polarity and ground disconnect protections
- Compatible PCB foot print and SPI software driver among the family

**12XS6D3**

---

**ENHANCED PENTA HIGH-SIDE SWITCH**

---



**EK SUFFIX (PB-FREE)  
98ASA00368D  
32-PIN SOICEP**

### Applications

- Low-voltage exterior lighting
- Incandescent bulbs (21 W)
- Light-emitting diodes (LEDs)

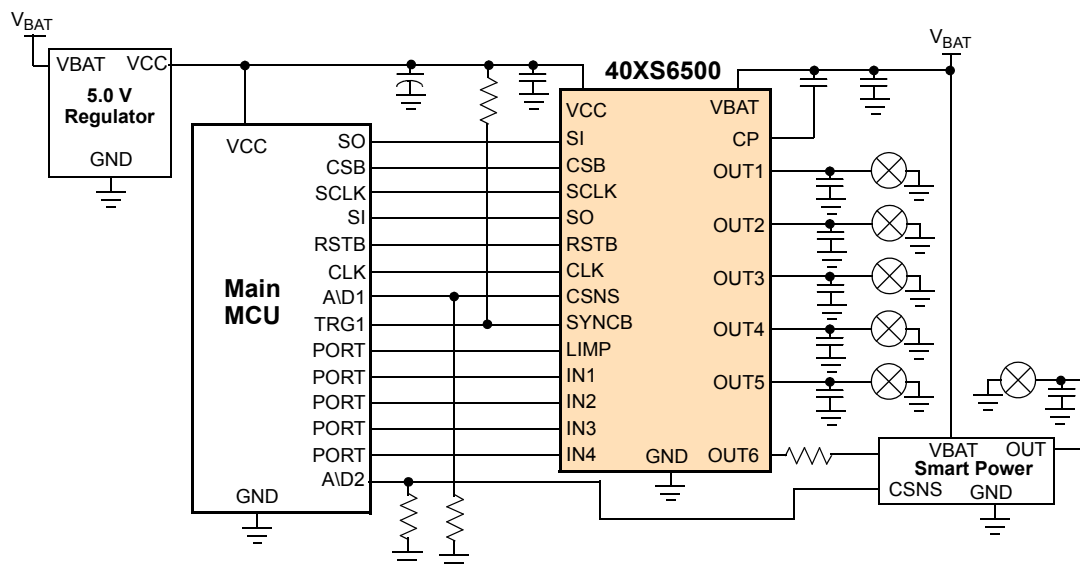

Figure 1. Penta 40 mΩ high-side simplified application diagram

\* This document contains certain information on a new product. Specifications and information herein are subject to change without notice.

# 1 Orderable parts

This section describes the part numbers available to be purchased along with their differences. Valid orderable part numbers are provided on the web. To determine the orderable part numbers for this device, go to <http://www.nxp.com> and perform a part number search for the following device numbers.

**Table 1. Orderable part variations**

Part number	Notes	Temperature (T <sub>A</sub> )	Package	OUT1 R <sub>DS(on)</sub>	OUT2 R <sub>DS(on)</sub>	OUT3 R <sub>DS(on)</sub>	OUT4 R <sub>DS(on)</sub>	OUT5 R <sub>DS(on)</sub>	OUT6
MC40XS6500EK	(1)	-40 °C to 125 °C	SOIC 32 pins exposed pad	40 mΩ	40 mΩ	40 mΩ	40 mΩ	40 mΩ	Yes
MC40XS6500BEK									

Notes

1. To order parts in tape and reel, add the R2 suffix to the part number.

# Table of Contents

1	Orderable parts	2
2	Internal block diagram	4
3	Pin connections	5
3.1	Pinout diagram	5
3.2	Pin definitions	5
4	General product characteristics	7
4.1	Relationship between ratings and operating requirements	7
4.2	Maximum ratings	8
4.3	Thermal characteristics	9
4.4	Operating conditions	9
4.5	Supply currents	10
5	General IC functional description and application information	11
5.1	Introduction	11
5.2	Features	11
5.3	Block diagram	12
5.4	Functional description	12
5.5	Modes of operation	13
5.6	SPI interface and configurations	15
6	Functional block requirements and behaviors	20
6.1	Self-protected high-side switches description and application information	20
6.2	Power supply functional block description and application information	50
6.3	Communication interface and device control functional block description and application information	51
7	Typical applications	55
7.1	Introduction	55
7.2	EMC and EMI considerations	57
7.3	PCB Layout Recommendations	58
7.3	PCB Layout Recommendations	58
7.4	Thermal information	59
8	Packaging	60
8.1	Marking information	60
8.2	Package mechanical dimensions	60
9	Revision History	64



## 2 Internal block diagram

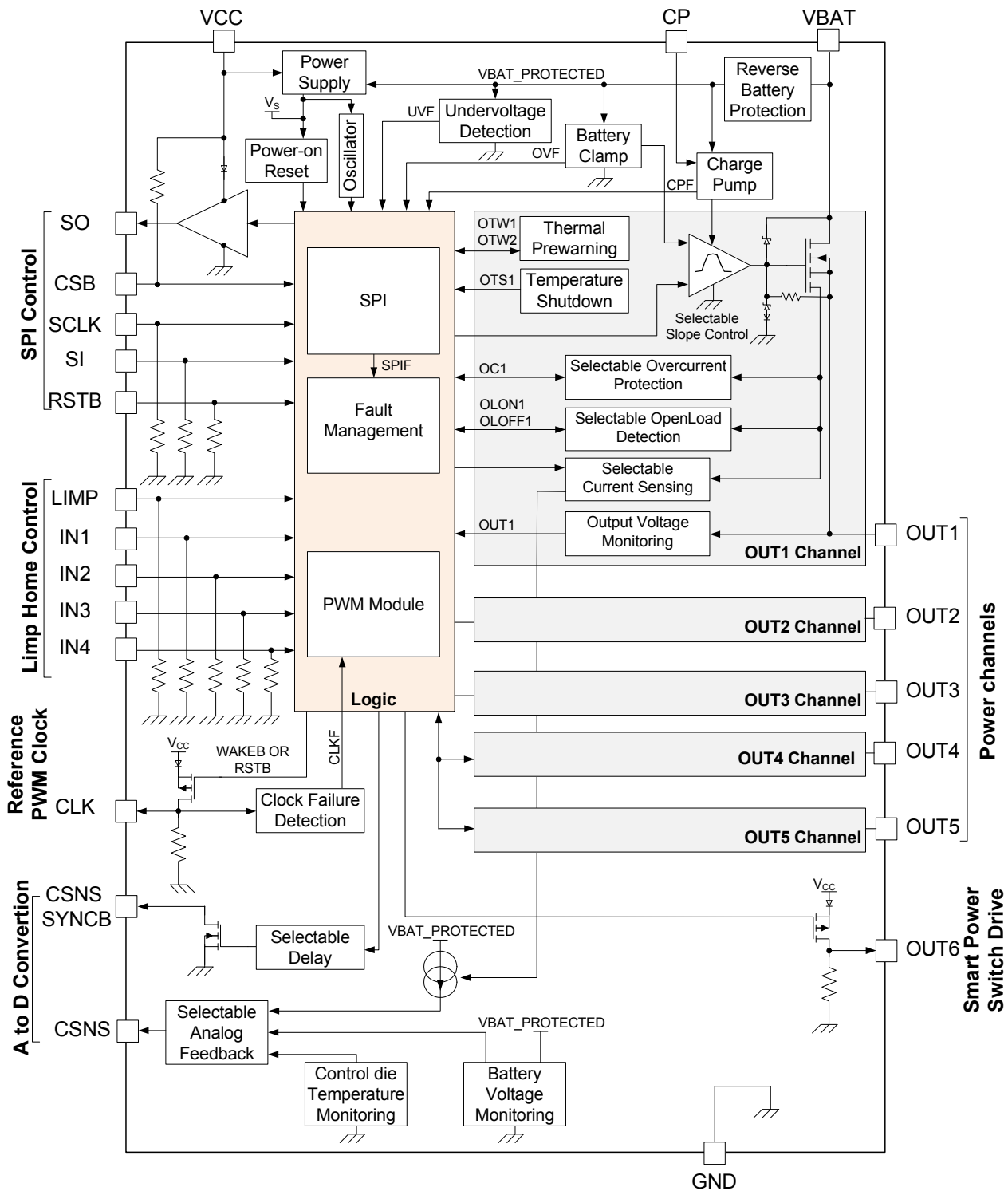

Figure 2. 12XS6 simplified internal block diagram (penta version)

## 3 Pin connections

### 3.1 Pinout diagram

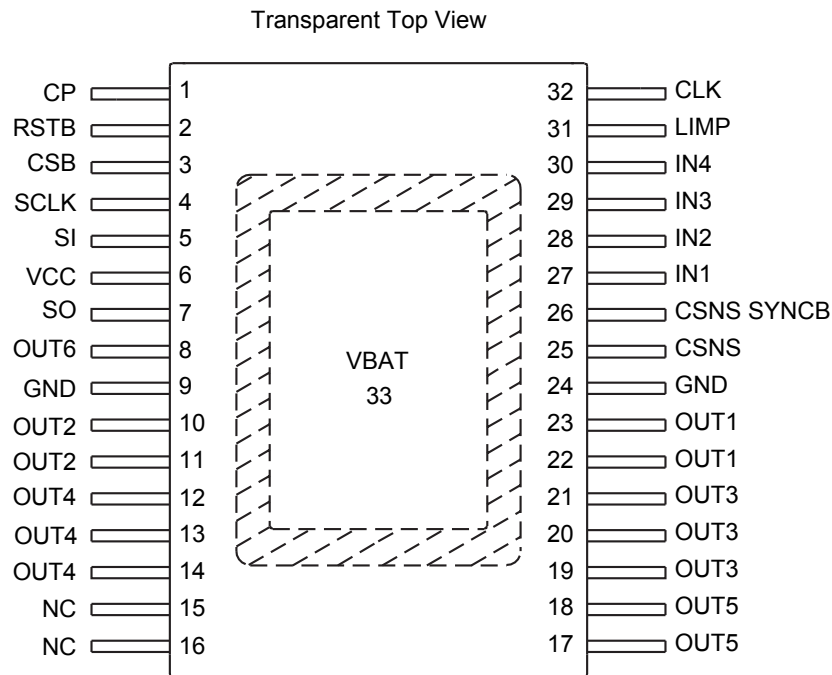

Figure 3. 12XS6 pinout diagram

### 3.2 Pin definitions

Table 2. 12XS6 pin definitions

Pin number	Pin name	Pin function	Formal name	Definition
1	CP	Internal supply	Charge Pump	This pin is the connection for an external capacitor for charge pump use only.
2	RSTB	SPI	Reset	This input pin is used to initialize the device configuration and fault registers, as well as place the device in a low-current sleep mode. This pin has a passive internal pull-down.
3	CSB	SPI	Chip Select	This input pin is connected to a chip select output of a master microcontroller (MCU). When this digital signal is high, SPI signals are ignored. Asserting this pin low starts the SPI transaction. The transaction is indicated as completed when this signal returns to a high level. This pin has a passive internal pull-up to $V_{CC}$ through a diode.
4	SCLK	SPI	Serial Clock	This input pin is connected to the MCU providing the required bit shift clock for SPI communication. This pin has a passive internal pull-down.
5	SI	SPI	Serial input	This pin is the data input of the SPI communication interface. The data at the input is sampled on the positive edge of the SCLK. This pin has a passive internal pull-down.
6	VCC	Power Supply	MCU Power Supply	This pin is a power supply pin is for internal logic, the SPI I/Os, and the OUT6 driver.
7	SO	SPI	Serial Output	This output pin is connected to the SPI serial data input pin of the MCU, or to the SI pin of the next device of a daisy chain of devices. The SPI changes on the negative edge of SCLK. When CSB is high, this pin is high-impedance.

**Table 2. 12XS6 pin definitions(continued)**

Pin number	Pin name	Pin function	Formal name	Definition
8	OUT6	Output	External Solid State	This output pin controls an external smart power switch by logic level. This pin has a passive internal pull-down.
9, 24	GND	Ground	Ground	These pins are the ground for the logic and analog circuitries of the device. For ESD and electrical parameter accuracy purpose, the ground pins must be shorted in the board.
10, 11	OUT2	Output	Channel #2	Protected high-side power output pins to the load.
12, 13, 14	OUT4	Output	Channel #4	Protected high-side power output pins to the load.
15, 16	NC	N/A	Not Connected	These pins may not be connected. It is recommended to connect those pins to ground.
17, 18	OUT5	Output	Channel #5	Protected high-side power output pins to the load.
19, 20, 21	OUT3	Output	Channel #3	Protected high-side power output pins to the load.
22, 23	OUT1	Output	Channel #1	Protected high-side power output pins to the load.
25	CSNS	Feedback	Current Sense	This pin reports an analog value proportional to the designated OUT[1:5] output current, or the temperature of the exposed pad, or the battery voltage. It is used externally to generate a ground referenced voltage for the microcontroller (MCU). Current recopy and analog voltage feedbacks are SPI programmable.
26	CSNS SYNCB	Feedback	Current Sense Synchronization	This open drain output pin allows synchronizing the MCU A/D conversion. This pin requires an external pull-up resistor to V <sub>CC</sub> .
27	IN1	Input	Direct Input #1	This input wakes up the device. This input pin is used to directly control corresponding channel in fail mode. During normal mode, the control of the outputs by the control inputs is SPI programmable. This pin has a passive internal pull-down.
28	IN2	Input	Direct Input #2	This input wakes up the device. This input pin is used to directly control corresponding channel in fail mode. During normal mode, the control of the outputs by the control inputs is SPI programmable. This pin has a passive internal pull-down.
29	IN3	Input	Direct Input #3	This input wakes up the device. This input pin is used to directly control corresponding channel in fail mode. During normal mode, the control of the outputs by the control inputs is SPI programmable. This pin has a passive internal pull-down.
30	IN4	Input	Direct Input #4	This input wakes up the device. This input pin is used to directly control corresponding channel in fail mode. During normal mode the control of the outputs by the control inputs is SPI programmable. This pin has a passive internal pull-down.
31	LIMP	Input	Limp Home	The fail mode can be activated by this digital input. This pin has a passive internal pull-down.
32	CLK	Input/Output	Device Mode Feedback Reference PWM Clock	This pin is an input/output pin. It is used to report the device sleep-state information. It is also used to apply the reference PWM clock which is divided by 2 <sup>8</sup> in normal operating mode. This pin has a passive internal pull-down.
33	VBAT	Power Supply	Battery Power Supply	This exposed pad connects to the positive power supply and is the source of operational power for the device.

# 4 General product characteristics

## 4.1 Relationship between ratings and operating requirements

The analog portion of device is supplied by the voltage applied to the VBAT exposed pad. Thereby the supply of internal circuitry (logic in case of V<sub>CC</sub> disconnect, charge pump, gate drive,...) is derived from the VBAT pin.

In case of reverse battery:

- the internal supply rail is protected (max. -16 V)
- the output drivers (OUT1:OUT5) are switched on to reduce the power consumption in the drivers, when using incandescent bulbs

The device's digital circuitry is powered by the voltage applied to the VCC pin. In case of a V<sub>CC</sub> disconnection, the logic part is supplied by the VBAT pin. The output driver for SPI signals, CLK pin (wake feedback) and OUT6 are supplied by the VCC pin only. This pin must be protected externally, in case of a reverse polarity, or in case of high-voltage disturbance.

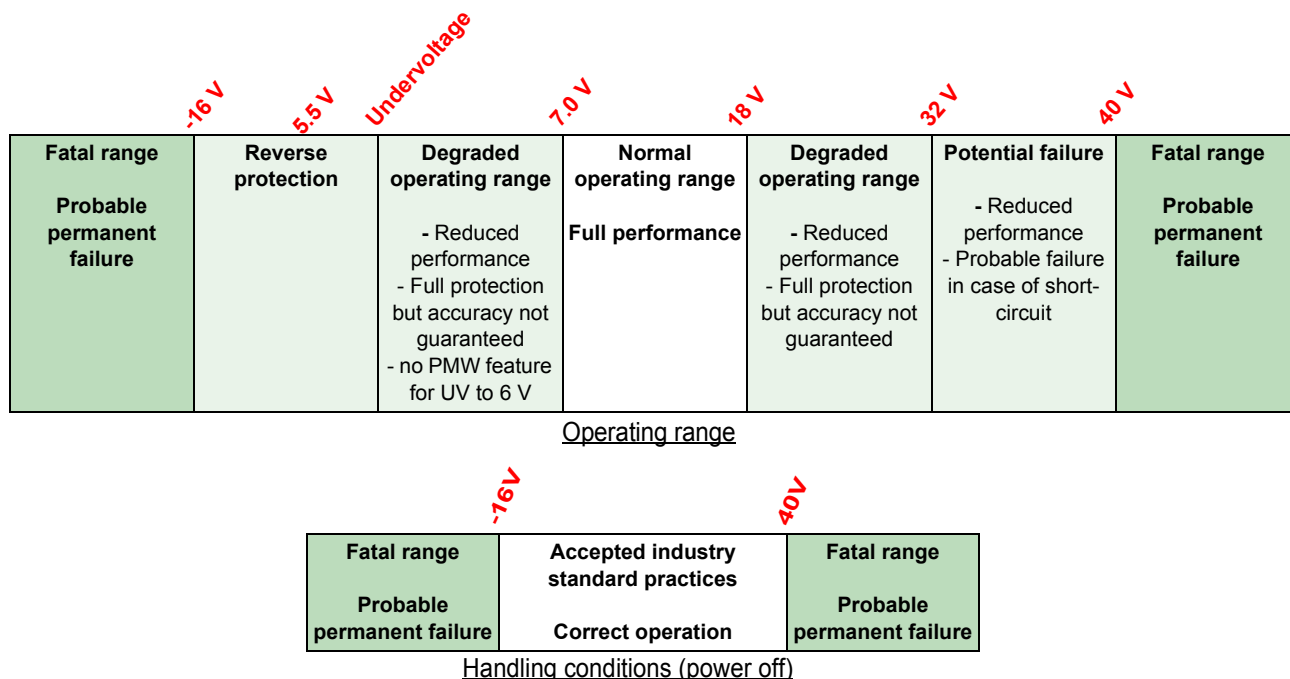

Figure 4. Ratings vs. operating requirements (VBAT pin)

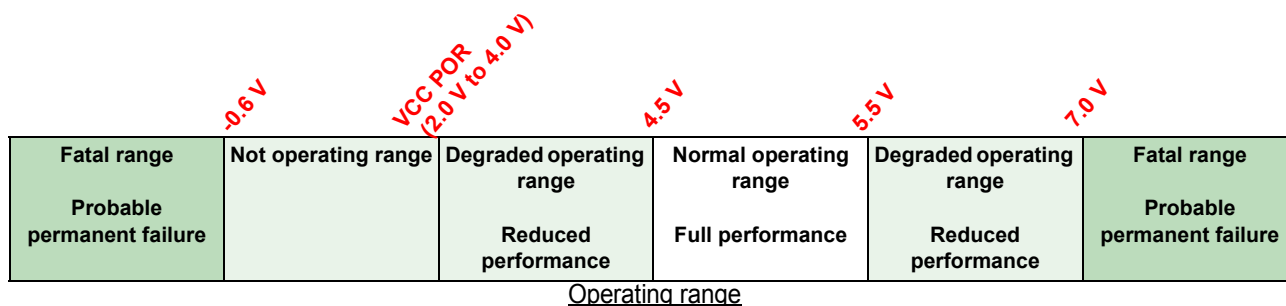

Figure 5. Ratings vs. operating requirements (VCC pin)



## 4.2 Maximum ratings

**Table 3. Maximum ratings**

All voltages are with respect to ground unless otherwise noted. Exceeding these ratings may cause a malfunction or permanent damage to the device.

Symbol	Description (rating)	Min.	Max.	Unit	Notes
<b>Electrical ratings</b>					
$V_{BAT}$	VBAT voltage range	-16	40	V	
$V_{CC}$	VCC logic supply voltage	-0.3	7.0	V	
$V_{IN}$	Digital input voltage <ul style="list-style-type: none"> <li>• IN1:IN4 and LIMP</li> <li>• CLK, SI, SCLK, CSB, and RSTB</li> </ul>	-0.3 -0.3	40 20	V	(2)
$V_{OUT}$	Digital output voltage <ul style="list-style-type: none"> <li>• SO, CSNS, SYNC, OUT6, CLK</li> </ul>	-0.3	20	V	(2)
$I_{CL}$	Negative digital input clamp current	–	5.0	mA	(3)
$I_{OUT}$	Power channel current	–	3.9	A	(4)
$E_{CL}$	Power channel clamp energy capability <ul style="list-style-type: none"> <li>• Initial <math>T_J = 25\text{ °C}</math></li> <li>• Initial <math>T_J = 150\text{ °C}</math></li> </ul>	– –	40 20	mJ	(5)
$V_{ESD}$	ESD voltage <ul style="list-style-type: none"> <li>• Human body model (HBM) - VBAT, power channel and GND pins</li> <li>• Human body model (HBM) - All other pins</li> <li>• Charge device model (CDM) - Corner pins</li> <li>• Charge device model (CDM) - All other pins</li> </ul>	-8000 -2000 -750 -500	+8000 +2000 +750 +500	V	(6)

**Notes**

2. Exceeding voltage limits on those pins may cause a malfunction or permanent damage to the device.
3. Maximum current in negative clamping for IN1:IN4, LIMP, RSTB, CLK, SI, SO, SCLK, and CSB pins.
4. Continuous high-side output current rating so long as maximum junction temperature is not exceeded. Calculation of maximum output current using package thermal resistance is required.
5. Active clamp energy using single-pulse method ( $L = 2.0\text{ mH}$ ,  $R_L = 0\ \Omega$ ,  $V_{BAT} = 14\text{ V}$ ). Refer to [Output clamps](#) section.
6. ESD testing is performed in accordance with the human body model (HBM) ( $C_{ZAP} = 100\text{ pF}$ ,  $R_{ZAP} = 1500\ \Omega$ ), and the charge device model.

## 4.3 Thermal characteristics

**Table 4. Thermal ratings**

All voltages are with respect to ground unless otherwise noted. Exceeding these ratings may cause a malfunction or permanent damage to the device.

Symbol	Description (rating)	Min.	Max.	Unit	Notes
<b>Thermal ratings</b>					
$T_A$ $T_J$	Operating temperature • Ambient • Junction	-40 -40	+125 +150	°C	
$T_{STG}$	Storage temperature	-55	+150	°C	
$T_{PPRT}$	Peak package reflow temperature during reflow	–	260	°C	(7) (8)

### Thermal resistance and package dissipation ratings

$R_{\theta JB}$	Junction-to-board	–	2.5	°C/W	(9)
$R_{\theta JA}$	Junction-to-ambient, natural convection, four-layer board (2s2p)	–	22	°C/W	(10) (11)
$R_{\theta JC}$	Junction-to-case (case top surface)	–	20	°C/W	(12)

### Notes

- Pin soldering temperature limit is for 10 seconds maximum duration. Not designed for immersion soldering. Exceeding these limits may cause malfunction or permanent damage to the device.
- NXP's package reflow capability meets Pb-free requirements for JEDEC standard J-STD-020C. for peak package reflow temperature and moisture sensitivity levels (MSL). Go to [www.NXP.com](http://www.NXP.com), search by part number [e.g. remove prefixes/suffixes and enter the core ID to view all orderable parts. (i.e. MC33xxx enter 33xxx), and review parametrics.
- Thermal resistance between the die and the printed circuit board per JEDEC JESD51-8. Board temperature is measured on the top surface of the board near the package.
- Junction temperature is a function of die size, on-chip power dissipation, package thermal resistance, mounting site (board) temperature, ambient temperature, air flow, power dissipation of other components on the board, and board thermal resistance.
- Per JEDEC JESD51-6 with the board (JESD51-7) horizontal.
- Thermal resistance between the die and the case top surface as measured by the cold plate method (MIL SPEC-883 Method 1012.1).

## 4.4 Operating conditions

This section describes the operating conditions of the device. Conditions apply to all the following data, unless otherwise noted.

**Table 5. Operating conditions**

All voltages are with respect to ground unless otherwise noted. Exceeding these ratings may cause a malfunction or permanent damage to the device.

Symbol	Ratings	Min.	Max.	Unit	Notes
$V_{BAT}$	Functional operating supply voltage - Device is fully functional. All features are operating.	7.0	18	V	
	Overvoltage range • Jump start • Load dump	– –	28 40	V	
	Reverse battery	-16	–	V	
$V_{CC}$	Functional operating supply voltage - Device is fully functional. All features are operating.	4.5	5.5	V	

## 4.5 Supply currents

This section describes the current consumption characteristics of the device.

**Table 6. Supply currents**

Characteristics noted under conditions  $4.5\text{ V} \leq V_{CC} \leq 5.5\text{ V}$ ,  $-40\text{ }^\circ\text{C} \leq T_A \leq 125\text{ }^\circ\text{C}$ ,  $\text{GND} = 0\text{ V}$ , unless otherwise noted. Typical values noted reflect the approximate parameter means at  $T_A = 25\text{ }^\circ\text{C}$  under nominal conditions, unless otherwise noted.

Symbol	Ratings	Min.	Typ.	Max.	Unit	Notes
<b>VBAT current consumptionS</b>						
$I_{QVBAT}$	Sleep mode measured at $V_{PWR} = 12\text{ V}$ <ul style="list-style-type: none"> <li>• <math>T_A = 25\text{ }^\circ\text{C}</math></li> <li>• <math>T_A = 125\text{ }^\circ\text{C}</math></li> </ul>	– –	1.2 10	5.0 30	$\mu\text{A}$	(13) (14)
$I_{VBAT}$	Operating mode measured at $V_{PWR} = 18\text{ V}$	–	7.0	8.0	mA	(14)
<b>VCC current consumptionS</b>						
$I_{QVCC}$	Sleep mode measured at $V_{CC} = 5.5\text{ V}$	–	0.05	5.0	$\mu\text{A}$	
$I_{VCC}$	Operating mode measured at $V_{PWR} = 5.5\text{ V}$ (SPI frequency 5.0 MHz)	–	2.8	4.0	mA	

**Notes**

13. With the OUT1:OUT5 power channels grounded.
14. With the OUT1:OUT5 power channels opened.

# 5 General IC functional description and application information

## 5.1 Introduction

The 12XS6 family is the latest SMARTMOS achievement in automotive drivers for all types of centralized automotive lighting applications. It is an evolution of the successful 12XS3 by providing improved features of a complete family of devices using NXP's latest and unique technologies for the controller and the power stages.

It consists of a scalable family of devices with different  $R_{DS(on)}$  and different number of outputs, compatible in terms of software driver and package footprint. It allows diagnosing the light-emitting diodes (LEDs) with an enhanced current sense precision with synchronization pin. It combines flexibility through daisy chainable SPI 5.0 MHz, extended digital and analog feedbacks, safety, and robustness. It integrates an enhanced PWM module with an 8-bit duty cycle capability and PWM frequency prescaler, per power channel.

## 5.2 Features

The main attributes of 12XS6 are:

- Dual, triple, quad, or penta high-side switches devices with overload, overtemperature, and undervoltage protection
- Control output for one external smart power switch
- 16-bit SPI communication interface with daisy chain capability
- Dedicated control inputs for use in fail mode
- Analog feedback pin with SPI programmable multiplexer and sync signal
- Channel diagnosis by SPI communication
- Advanced current sense mode for LED usage
- Synchronous PWM module with external clock, prescaler and multi-phase feature
- Excellent EMC behavior
- Power net and reverse polarity protection
- Ultra low-power mode
- Scalable and flexible family concept
- Board layout compatible SOIC54 and SOIC32 package with exposed pad

## 5.3 Block diagram

The choice of multi-die technology in SOIC exposed pad package including low cost vertical trench FET power die associated with smart power control die lead to an optimized solution.

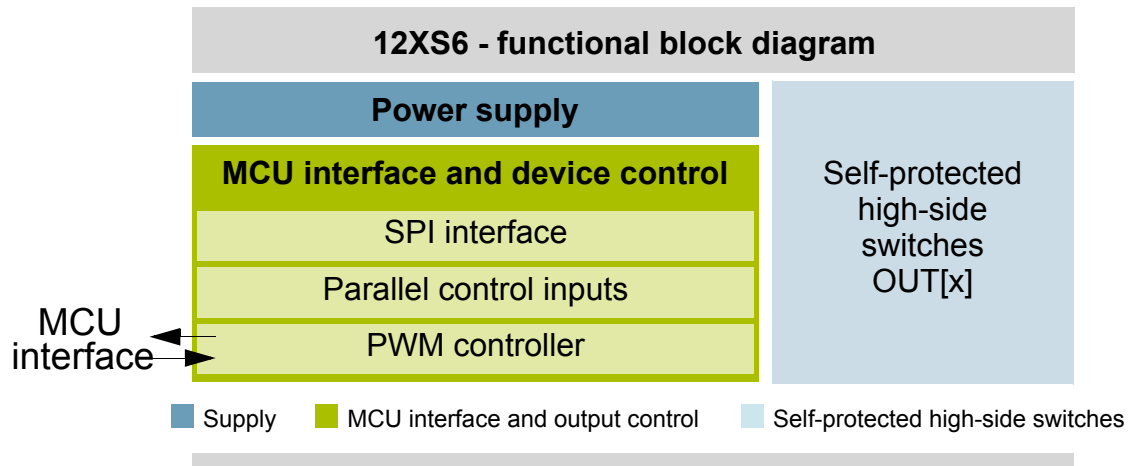

Figure 6. Functional block diagram

### 5.3.1 Self-protected high-side switches

OUT1:OUT5 are the output pins of the power switches. The power channels are protected against various kinds of short-circuits and have active clamp circuitry which may be activated when switching off inductive loads. Many protective and diagnostic functions are available.

### 5.3.2 Power supply

The device operates with supply voltages from 5.5 V to 40 V ( $V_{BAT}$ ), but is full spec. compliant only between 7.0 V and 18 V. The  $V_{BAT}$  pin supplies power to the internal regulator, analog, and logic circuit blocks. The  $V_{CC}$  pin (5.0 V typ.) supplies the output register of the serial peripheral interface (SPI). Consequently, the SPI registers cannot be read without presence of  $V_{CC}$ . The employed IC architecture guarantees a low quiescent current in sleep mode.

### 5.3.3 MCU interface and device control

In normal mode the power output channels are controlled by the embedded PWM module, which is configured by the SPI register settings. For bidirectional SPI communication,  $V_{CC}$  has to be in the authorized range. Failure diagnostics and configuration are also performed through the SPI port. The reported failure types are: open load, short-circuit to battery, severe short-circuit to ground, overcurrent, overtemperature, clock-fail, and under and overvoltage. The device allows driving loads at different frequencies up to 400 Hz.

## 5.4 Functional description

The device has four fundamental operating modes: sleep, normal, fail, and power off. It possesses multiple high-side switches (power channels) each of which can be controlled independently:

- in normal mode by SPI interface. A second supply voltage ( $V_{CC}$ ) is required for bidirectional SPI communication
- in fail mode by the corresponding direct inputs IN1:IN4. The OUT5 for the penta version and the OUT6 are off in this mode



## 5.5 Modes of operation

The operating modes are based on the signals:

- wake = (IN1\_ON) OR (IN2\_ON) OR (IN3\_ON) OR (IN4\_ON) OR (RST). More details in [Logic I/O plausibility check](#) section
- fail = (SPI\_fail) OR (LIMP). More details in [Loss of communication interface](#) section

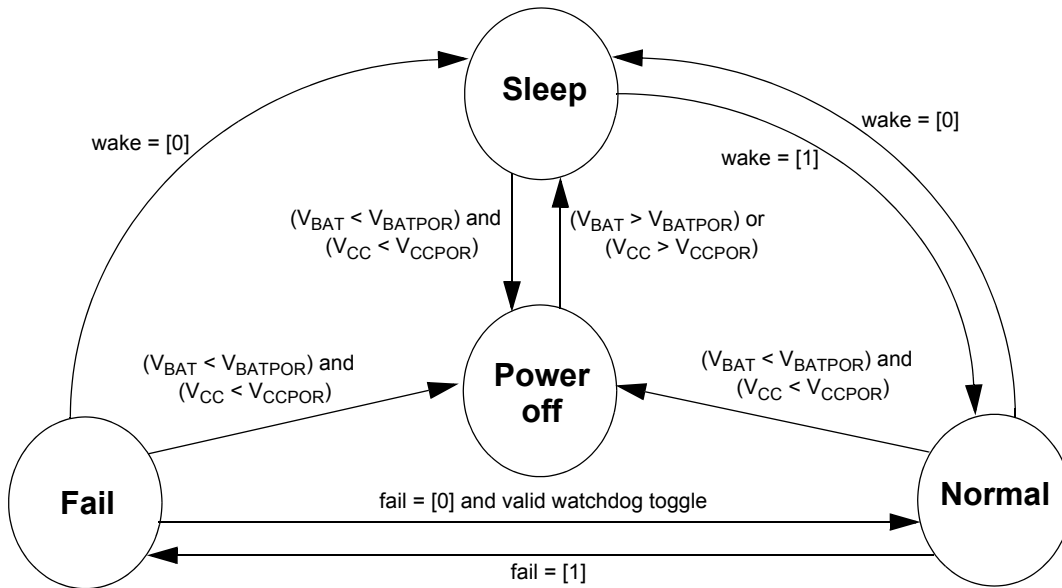

Figure 7. General IC operating modes

### 5.5.1 Power off mode

The power off mode is applied when  $V_{BAT}$  and  $V_{CC}$  are below the power on reset threshold ( $V_{BAT\ POR}$ ,  $V_{CC\ POR}$ ). In power off, no functionality is available but the device is protected by the clamping circuits. Refer to the [Supply voltages disconnection](#) section.

### 5.5.2 Sleep mode

The sleep mode is used to provide ultra low-current consumption. During sleep mode:

- the component is inactive and all outputs are disabled
- the outputs are protected by the clamping circuits
- the pull-up/pull-down resistors are present

The sleep mode is the default mode of the device after applying the supply voltages ( $V_{BAT}$  or  $V_{CC}$ ) prior to any wake-up condition (wake = [0]). The wake-up from sleep mode is provided by the wake signal.

### 5.5.3 Normal Mode

The normal mode is the regular operating mode of the device. The device is in normal mode, when the device is in wake state (wake = [1]) and no fail condition (fail = [0]) is detected.

During normal mode:

- the power outputs are under control of the SPI
- the power outputs are controlled by the programmable PWM module
- the power outputs are protected by the overload protection circuit
- the control of the power outputs by SPI programming
- the digital diagnostic feature transfers status of the smart switch via the SPI
- the analog feedback output (CSNS and CSNS SYNC) can be controlled by the SPI

The channel control (CHx) can be summarized:

- CH1:4 controlled by ONx or iINx (if it is programmed by the SPI)
- CH5:6 controlled by ONx
- Rising CHx by definition means starting overcurrent window for OUT1:5

### 5.5.4 Fail mode

The device enters the fail mode, when:

- the LIMP input pin is high (logic [1])
- or the SPI failure is detected

During fail mode (wake = [1] & fail = [1]):

- the OUT1:OUT4 outputs are directly controlled by the corresponding control inputs (IN1:IN4)
- the OUT5:OUT6 are turned off
- the PWM module is not available
- while no SPI control is feasible, the SPI diagnosis is functional (depending on the fail mode condition):
  - the SO shall report the content of SO register defined by SOA0:3 bits
  - the outputs are fully protected in case of an overload, overtemperature and undervoltage
  - no analog feedback is available
  - the max. output overcurrent profile is activated (OCLO and window times)
  - in case of an overload condition or undervoltage, the auto-restart feature controls the OUT1:OUT4 outputs
  - in case of an overtemperature condition or OCHI1 detection or severe short-circuit detection, the corresponding output is latched OFF until a new wake-up event

The channel control (CHx) can be summarized:

- CH1: 4 controlled by iINx, while the overcurrent windows are controlled by IN\_ONx
- CH5: 6 are off

### 5.5.5 Mode transitions

After a wake-up:

- a power on reset is applied and all SPI SI and SO registers are cleared (logic[0])
- the faults are blanked during  $t_{BLANKING}$

The device enters in normal mode after start-up if following sequence is provided:

- $V_{BAT}$  and  $V_{CC}$  power supplies must be above their undervoltage thresholds (sleep mode)
- generate wake-up event (wake = 1) setting RSTB from 0 to 1

The device initialization is completed after 50  $\mu$ sec (typ.). During this time, the device is robust, in case of  $V_{BAT}$  interrupts higher than 150 nsec.

The transition from 'normal mode' to 'fail mode' is executed immediately when a fail condition is detected.

During the transition, the SPI SI settings are cleared and the SPI SO registers are not cleared.

When the fail mode condition was a:

- LIMP input, WD toggle timeout, WD toggle sequence or the SPI modulo 16 error, the SPI diagnosis is available during fail mode
- SI/SO stuck to static level, the SPI diagnosis is not available during fail mode

The transition from 'fail mode' to 'normal mode' is enabled, when:

- the fail condition is removed and
- two SPI commands are sent within a valid watchdog cycle (first WD = [0] and then WD = [1])

During this transition:

- all SPI SI and SO registers are cleared (logic[0])
- the DSF (device status flag) in the registers #1:#7 and the RCF (register clearer flag) in the device status register #1 are set (logic[1])

To delatch the RCF diagnosis, a read command of the quick status register #1 must be performed.

## 5.6 SPI interface and configurations

### 5.6.1 Introduction

The SPI is used to:

- control the device in case of normal mode
- provide diagnostics in case of normal and fail mode

The SPI is a 16-bit full-duplex synchronous data transfer interface with daisy chain capability.

The interface consists of four I/O lines with 5.0 V CMOS logic levels and termination resistors:

- The SCLK pin clocks the internal shift registers of the device
- The SI pin accepts data into the input shift register on the rising edge of the SCLK signal
- The SO pin changes its state on the rising edge of SCLK and reads out on the falling edge
- The CSB enables the SPI interface
  - with the leading edge of CSB the registers are loaded
  - while CSB is logic [0] SI/SO data are shifted
  - with the trailing edge of the CSB signal, SPI data is latched into the internal registers
  - when CSB is logic [1], the signals at the SCLK and SI pins are ignored and SO is high-impedance

When the RSTB input is:

- low (logic [0]), the SPI and the fault registers are reset. The wake state then depends on the status of the input pins (IN\_ON1:IN\_ON4)
- high (logic[1]), the device is in wake status and the SPI is enabled

The functionality of the SPI is checked by a plausibility check. In case of the SPI failure, the device enters the fail mode.

### 5.6.2 SPI input register and bit descriptions

The first nibble of the 16 bit data word (D15:D12) serves as address bits.

Register	SI address				SI data												
	#	D15	D14	D13	D12	D11	D10	D9	D8	D7	D6	D5	D4	D3	D2	D1	D0
name	8	4 Bit address				WD	11 Bit address										

11 bits (D10:D1) are used as data bits.

The D11 bit is the WD toggle bit. This bit has to be toggled with each write command.

When the toggling of the bit is not executed within the WD timeout, the SPI fail is detected.

All register values are logic [0] after a reset. The predefined value is off/inactive, unless otherwise noted.

Register	SI address					SI data											
	#	D15	D14	D13	D12	D11	D10	D9	D8	D7	D6	D5	D4	D3	D2	D1	D0
Initialisation 1	0	0	0	0	0	WD	WD SEL	SYNC EN1	SYNC EN0	MUX2	MUX1	MUX0	SOA MODE	SOA3	SOA2	SOA1	SOA0
initialisation 2	1	0	0	0	1	WD	OCHI THERMAL	OCHI TRANSIENT	NO HID1	NO HID0	OCHI OD5	OCHI OD4	OCHI OD3	OCHI OD2	OCHI OD1	PWM sync	OTW SEL
CH1 control	2	0	0	1	0	WD	PH11	PH01	ON1	PWM71	PWM61	PWM51	PWM41	PWM31	PWM21	PWM11	PWM01
CH2 control	3	0	0	1	1	WD	PH12	PH02	ON2	PWM72	PWM62	PWM52	PWM42	PWM32	PWM22	PWM12	PWM02
CH3 control	4	0	1	0	0	WD	PH13	PH03	ON3	PWM73	PWM63	PWM53	PWM43	PWM33	PWM23	PWM13	PWM03
CH4 control	5	0	1	0	1	WD	PH14	PH04	ON4	PWM74	PWM64	PWM54	PWM44	PWM34	PWM24	PWM14	PWM04
CH5 control	6	0	1	1	0	WD	PH15	PH05	ON5	PWM75	PWM65	PWM55	PWM45	PWM35	PWM25	PWM15	PWM05
CH6 control	7	0	1	1	1	WD	PH16	PH06	ON6	PWM76	PWM66	PWM56	PWM46	PWM36	PWM26	PWM16	PWM06
output control	8	1	0	0	0	WD	PSF5	PSF4	PSF3	PSF2	PSF1	ON6	ON5	ON4	ON3	ON2	ON1
Global PWM control	9-1	1	0	0	1	WD	0	X	X	X	X	GPWM EN6	GPWM EN5	GPWM EN4	GPWM EN3	GPWM EN2	GPWM EN1
	9-2	1	0	0	1	WD	1	X	X	GPWM7	GPWM6	GPWM5	GPWM4	GPWM3	GPWM2	GPWM1	GPWM0
over current control	10-1	1	0	1	0	WD	0	OCL05	OCL04	OCL03	OCL02	OCL01	ACM EN5	ACM EN4	ACM EN3	ACM EN2	ACM EN1
	10-2	1	0	1	0	WD	1	NO OCHI5	NO OCHI4	NO OCHI3	NO OCHI2	NO OCHI1	SHORT OCHI5	SHORT OCHI4	SHORT OCHI3	SHORT OCHI2	SHORT OCHI1
input enable	11	1	0	1	1	WD	0	X	X	INEN14	INEN04	INEN13	INEN03	INEN12	INEN02	INEN11	INEN01
prescaler settings	12-1	1	1	0	0	WD	0	PRS15	PRS05	PRS14	PRS04	PRS13	PRS03	PRS12	PRS02	PRS11	PRS01
	12-2	1	1	0	0	WD	1	X	X	X	X	X	X	X	X	PRS16	PRS06
OL control	13-1	1	1	0	1	WD	0	OLON DGL5	OLON DGL4	OLON DGL3	OLON DGL2	OLON DGL1	OLOFF EN5	OLOFF EN4	OLOFF EN3	OLOFF EN2	OLOFF EN1
OLLED control	13-2	1	1	0	1	WD	1	res	res	res	res	OLLED TRIG	OLLED EN5	OLLED EN4	OLLED EN3	OLLED EN2	OLLED EN1
increment / decrement	14	1	1	1	0	WD	INCR SGN	INCR15	INCR05	INCR14	INCR04	INCR13	INCR03	INCR12	INCR02	INCR11	INCR01
testmode	15	1	1	1	1	X	X	X	X	X	X	X	X	X	X	X	X

WD #0-#14 = watchdog toggle bit	#0	<b>MUX2</b>	<b>MUX1</b>	<b>MUX0</b>	<b>CSNS</b>		
SOA0 ~ SOA3 #0 = address of next SO data word	0	0	0	0	off		
SOA MODE #0 = single read address of next SO data word	0	0	0	1	OUT1 current		
MUX0 ~ MUX2 #0 = CSNS multiplexer setting	0	1	0	0	OUT2 current		
SYNC EN0 ~ SYNC EN1 #0 = SYNC delay setting	0	1	1	0	OUT3 current		
WD SEL #0 = watchdog timeout select	1	0	0	0	OUT4 current		
OTW SEL #1 = over temperature warning threshold selection	1	0	1	0	OUT5 current		
PWM SYNC #1 = reset clock module	1	1	0	0	VBAT monitor		
OCHI ODx #1 = OCHI window on load demand	1	1	1	1	control die temp.monitor		
NO HIDx #1 = HID outputs selection	#0	<b>SYNC EN1</b>	<b>SYNC EN0</b>	<b>Sync status</b>			
OCHI THERMAL #1 = OCHI1 level depending on control die temperature	0	0	0	sync off			
OCHI TRANSIENT #1 = OCHIx levels adjusted during OFF-to-ON transition	0	0	1	valid			
PWM0x ~ PWM7x #2-#7 = PWM value (8Bit)	1	0	0	trig0			
PH0x ~ PH1x #2-#7 = phase control	1	1	1	trig1/2			
ONx #2-#8 = channel on/off incl. OCHI control	#2-#7	<b>PH 1x</b>	<b>PH 0x</b>	<b>Phase</b>			
PSFx #8 = pulse skipping feature for power output channels	0	0	0	0°			
GPWM ENx #9-1 = global PWM enable	0	0	1	90°			
GPWM1 ~ GPWM7 #9-2 = global PWM value (8Bit)	1	0	0	180°			
ACM ENx #10-1 = advanced current sense mode enable	1	0	1	270°			
OCL0x #10-1 = OCL0 level control	#11	<b>ONx</b>	<b>INEN1x</b>	<b>INEN0x</b>	<b>GPWM ENx</b>	<b>INx=0</b>	<b>INx=1</b>
SHORT OCHIx #10-2 = use short OCHI window time	0	x	x	x	OFF	x	OFF
NO OCHIx #10-2 = start with OCL0 threshold	0	0	0	0	ON	individual	ON
INEN0x ~ INEN1x #11 = input enable control	0	0	0	1	ON	global	ON
PRS0x ~ PRS1x #12 = pre scaler setting	0	0	1	0	OFF	individual	ON
OLOFF ENx #13-1 = OL load in off state enable	1	0	1	1	OFF	global	ON
OLON DGLx #13-1 = OL ON deglitch time	1	0	0	0	OFF	individual	ON
OLLED ENx #13-2 = OL LED mode enable	1	1	0	0	OFF	individual	ON
OLLED TRIG #13-2 = trigger for OLLED detection in 100% d.c.	1	1	0	1	OFF	global	ON
INCR SGN #14 = PWM increment / decrement sign	1	1	0	0	ON	individual	ON
INCR0x ~ INCR1x #14 = PWM increment / decrement setting	1	1	1	1	ON	global	ON
#1	<b>NO HID1 NO HID0</b>	<b>HID Selection</b>					
	0	0	available for all channels				
	0	1	available for channel 3 only				
	1	0	available for channels 3 and 4 only				
	1	1	unavailable for all channels				
#12	<b>PRS 1x</b>	<b>PRS 0x</b>	<b>PRS divider</b>				
	0	0	/4	25Hz ... 100Hz			
	0	1	/2	50Hz ... 200Hz			
	1	x	/1	100Hz ... 400Hz			
#14	<b>INCR SGN</b>	<b>increment/decrement</b>					
	0	decrement					
	1	increment					
#14	<b>INCR 1x</b>	<b>INCR 0x</b>	<b>increment/decrement</b>				
	0	0	no increment/decrement				
	0	1	4 LSB				
	1	0	8 LSB				
	1	1	16 LSB				

## 5.6.3 SPI output register and bit descriptions

The first nibble of the 16 Bit data word (D12:D15) serves as address bits.

All register values are logic [0] after a reset, except DSF and RCF bits. The predefined value is off/inactive unless otherwise noted.

Register	SO address					SO data											
	#	D15	D14	D13	D12	D11	D10	D9	D8	D7	D6	D5	D4	D3	D2	D1	D0
not used	0	0	0	0	0	X	X	X	X	X	X	X	X	X	X	X	X
quick status	1	0	0	0	1	FM	DSF	OVLf	OLf	CPF	RCF	CLKF	QSF5	QSF4	QSF3	QSF2	QSF1
CH1 status	2	0	0	1	0	FM	DSF	OVLf	OLf	res	OTS1	OTW1	OC21	OC11	OC01	OLON1	OLOFF1
CH2 status	3	0	0	1	1	FM	DSF	OVLf	OLf	res	OTS2	OTW2	OC22	OC12	OC02	OLON2	OLOFF2
CH3 status	4	0	1	0	0	FM	DSF	OVLf	OLf	res	OTS3	OTW3	OC23	OC13	OC03	OLON3	OLOFF3
CH4 status	5	0	1	0	1	FM	DSF	OVLf	OLf	res	OTS4	OTW4	OC24	OC14	OC04	OLON4	OLOFF4
CH5 status	6	0	1	1	0	FM	DSF	OVLf	OLf	res	OTS5	OTW5	OC25	OC15	OC05	OLON5	OLOFF5
device status	7	0	1	1	1	FM	DSF	OVLf	OLf	res	res	res	TMF	OvF	UVF	SPIf	iLIMP
I/O status	8	1	0	0	0	FM	res	TOGGLE	iIN4	iIN3	iIN2	iIN1	OUT5	OUT4	OUT3	OUT2	OUT1
device ID	9	1	0	0	1	FM	UVF	res	res	DEVID7	DEVID6	DEVID5	DEVID4	DEVID3	DEVID2	DEVID1	DEVID0
not used	10	1	0	1	0	X	X	X	X	X	X	X	X	X	X	X	X
not used	11	1	0	1	1	X	X	X	X	X	X	X	X	X	X	X	X
not used	12	1	1	0	0	X	X	X	X	X	X	X	X	X	X	X	X
not used	13	1	1	0	1	X	X	X	X	X	X	X	X	X	X	X	X
not used	14	1	1	1	0	X	X	X	X	X	X	X	X	X	X	X	X
testmode	15	1	1	1	1	X	X	X	X	X	X	X	X	X	X	X	X

<b>QSFx</b> #1 = quick status (OC or OTW or OTS or OLON or OLOFF)	#2-#6	<b>OC2x</b>	<b>OC1x</b>	<b>OC0x</b>	<b>over current status</b>
<b>CLKF</b> #1 = PWM clock fail flag		0	0	0	no overcurrent
<b>RCF</b> #1 = register clear flag		0	0	1	OCH11
<b>CPF</b> #1 = charge pump flag		0	1	0	OCH12
<b>OLf</b> #1-#7 = open load flag (wired or of all OL signals)		0	1	1	OCH13
<b>OVLf</b> #1-#7 = over load flag (wired or of all OC and OTS signals)		1	0	0	OCLO
<b>DSF</b> #1-#7 = device status flag (UVF or OVf or CPF or RCF or CLKF or TMF)		1	0	1	OCH10D
<b>FM</b> #1-#8 = fail mode flag		1	1	0	SSC
<b>OLOFFx</b> #2-#6 = open load in off state status bit		1	1	1	not used
<b>OLONx</b> #2-#6 = open load in on state status bit	#9	<b>DEVID2</b>	<b>DEVID1</b>	<b>DEVID0</b>	<b>device type</b>
<b>OTWx</b> #2-#6 = over temperature warning bit		0	0	0	Penta3/2
<b>OTSx</b> #2-#6 = over temperature shutdown bit		0	0	1	Penta0/5
<b>iLIMP</b> #7 = status of LIMP input after deglitcher (reported in real time)		0	1	0	Quad2/4
<b>SPIf</b> #7 = SPI fail flag		0	1	1	Quad0/4
<b>UVF</b> #7 = under voltage flag		1	0	0	Triple1/2
<b>OVf</b> #7 = over voltage flag		1	0	1	Triple0/3
<b>TMF</b> #7 = testmode activation flag		1	1	0	res
<b>OUTx</b> #8 = status of VBAT/2 comparator (reported in real time)		1	1	1	res
<b>iINx</b> #8 = status of INx pin after deglitcher (reported in real time)					
<b>TOGGLE</b> #8 = status of INx_ON signals (IN1_ON or IN2_ON or IN3_ON or IN4_ON)					
<b>DEVID0 ~ DEVID2</b> #9 = device type					
<b>DEVID3 ~ DEVID4</b> #9 = device family					
<b>DEVID5 ~ DEVID7</b> #9 = design status (incremented number)					



## 5.6.4 Timing diagrams

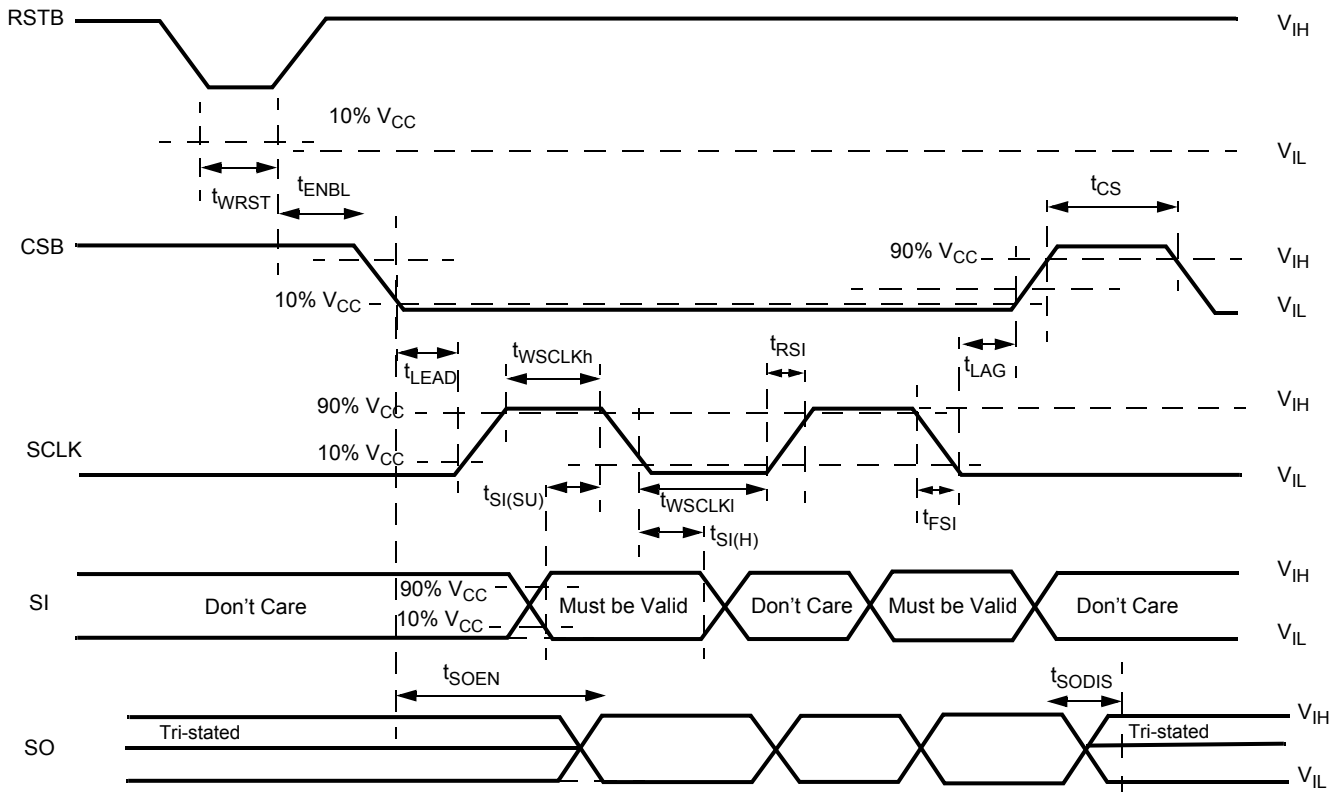

Figure 8. Timing requirements during SPI communication

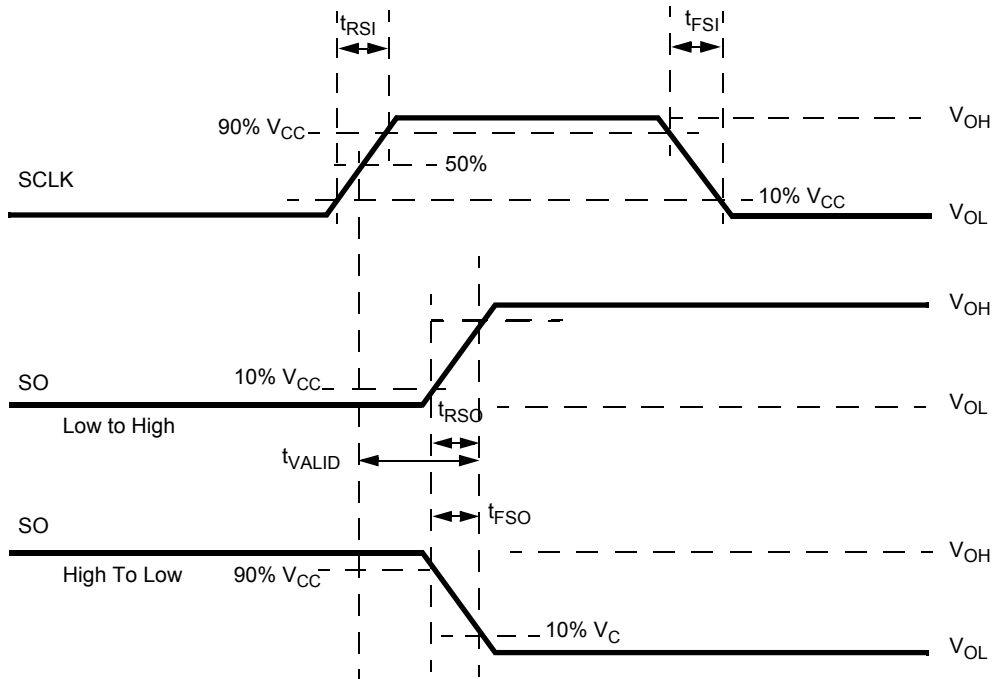

Figure 9. Timing diagram for serial output (SO) data communication

## 5.6.5 Electrical Characterization

**Table 7. Electrical characteristics**

Characteristics noted under conditions  $4.5\text{ V} \leq V_{CC} \leq 5.5\text{ V}$ ,  $-40\text{ }^\circ\text{C} \leq T_A \leq 125\text{ }^\circ\text{C}$ ,  $\text{GND} = 0\text{ V}$ , unless otherwise noted. Typical values noted reflect the approximate parameter means at  $T_A = 25\text{ }^\circ\text{C}$  under nominal conditions, unless otherwise noted.

Symbol	Characteristic	Min.	Typ.	Max.	Unit	Notes
<b>SPI signals CSB, SI, SO, SCLK, SO</b>						
$f_{\text{SPI}}$	SPI clock frequency	0.5	–	5.0	MHz	
$V_{\text{IH}}$	Logic input high state level (SI, SCLK, CSB, RSTB)	3.5	–	–	V	
$V_{\text{IH(WAKE)}}$	Logic input high state level for wake-up (RSTB)	3.75	–	–	V	
$V_{\text{IL}}$	Logic input low state level (SI, SCLK, CSB, RSTB)	–	–	0.85	V	
$V_{\text{OH}}$	Logic output high state level (SO)	$V_{CC} - 0.4$	–	–	V	
$V_{\text{OL}}$	Logic output low state level (SO)	–	–	0.4	V	
$I_{\text{IN}}$	Logic input leakage current in inactive state (SI = SCLK = RSTB = [0] and CSB = [1])	-0.5	–	+0.5	$\mu\text{A}$	
$I_{\text{OUT}}$	Logic output tri-state leakage current (SO from 0 V to $V_{CC}$ )	-10	–	+1.0	$\mu\text{A}$	
$R_{\text{PULL}}$	Logic input pull-up/pull-down resistor	25	–	100	$\text{k}\Omega$	
$C_{\text{IN}}$	Logic input capacitance	–	–	20	pF	(15)
$t_{\text{RST\_DGL}}$	RSTB deglitch time	7.5	10	12.5	$\mu\text{s}$	
$t_{\text{SO}}$	SO rising and falling edges with 80 pF	–	–	20	ns	
$t_{\text{WCLKh}}$	Required high state duration of SCLK (required setup time)	80	–	–	ns	
$t_{\text{WCLKl}}$	Required low state duration of SCLK (required setup time)	80	–	–	ns	
$t_{\text{CS}}$	Required duration from the rising to the falling edge of CSB (required setup time)	1.0	–	–	$\mu\text{s}$	
$t_{\text{RST}}$	Required low state duration for reset RSTB	1.0	–	–	$\mu\text{s}$	
$t_{\text{LEAD}}$	Falling edge of CSB to rising edge of SCLK (required setup time)	320	–	–	ns	
$t_{\text{LAG}}$	Falling edge of SCLK to rising edge of CSB (required setup lag time)	100	–	–	ns	
$t_{\text{SI(SU)}}$	SI to falling edge of SCLK (required setup time)	20	–	–	ns	
$t_{\text{SI(H)}}$	Falling edge of SCLK to SI (required hold time of the SI signal)	20	–	–	ns	
$t_{\text{RSI}}$	SI, CSB, SCLK, Max. rise time allowing operation at maximum $f_{\text{SPI}}$	–	20	50	ns	
$t_{\text{FSI}}$	SI, CSB, SCLK, Max. fall time allowing operation at maximum $f_{\text{SPI}}$	–	20	50	ns	
$t_{\text{SO(EN)}}$	Time from falling edge of CSB to reach low-impedance on SO (access time)	–	–	60	ns	
$t_{\text{SO(DIS)}}$	Time from rising edge of CSB to reach tri-state on SO	–	–	60	ns	

**Notes**

15. Parameter is derived from simulations.

## 6 Functional block requirements and behaviors

### 6.1 Self-protected high-side switches description and application information

#### 6.1.1 Features

Up to five power outputs are foreseen to drive automotive light applications. The outputs are optimized for driving automotive bulbs, LEDs, and other primarily resistive loads.

The smart switches are controlled by use of high sophisticated gate drivers. The gate drivers provide:

- output pulse shaping
- output protections
- active clamps
- output diagnostics

#### 6.1.2 Output pulse shaping

The outputs are controlled with a closed loop active pulse shaping in order to provide the best compromise between:

- low switching losses
- low EMC emission performance
- minimum propagation delay time

Depending on the programming of the prescaler setting register #12-1, #12-2 the switching speeds of the outputs are adjusted to the output frequency range of each channel. The edge shaping shall be designed according the following table:

Divider factor	PWM freq. (Hz)		PWM period (ms)		D.C. range (hex)		D.C. range (LSB)		min. on/off duty cycle time (µs)
	min.	max.	min.	max.	min.	max.	min.	max	
4	25	100	10	40	03	FB	4	252	156
2	50	200	5	20	07	F7	8	248	156
1	100	400	2.5	10	07	F7	8	248	78

The edge shaping provides full symmetry for rising and falling transition:

- the slopes for the rising and falling edge are matched to provide best EMC emission performance
- the shaping of the upper edges and the lower edges is matched to provide the best EMC emission performance
- the propagation delay time for the rising edge and the falling edge are matched in order to provide true duty cycle control of the output duty cycle error  $\leq 1$  LSB at the max. frequency
- a digital regulation loop is used to minimize the duty cycle error of the output signal

##### 6.1.2.1 SPI control and configuration

A synchronous clock module is integrated for optimized control of the outputs. The PWM frequency and output timing during normal mode is generated from the clock input (CLK) by the integrated PWM module. In case of a clock fail (very low frequency, very high frequency), the output duty cycle is 100%. Each output (OUT1:OUT6) can be controlled by an individual channel control register:

Register	SI address					SI data											
	#	D15	D14	D13	D12	D11	D10	D9	D8	D7	D6	D5	D4	D3	D2	D1	D0
CHx control	2-7	channel address				WD	PH1x	PH0x	Onx	PWM7	PWM6	PWM5	PWM4	PWM3	PWM2	PWM1	PWM0
										x	x	x	x	x	x	x	

where:

- PH0x:PH1x: phase assignment of the output channel x
- ONx: on/off control including overcurrent window control of the output channel x
- PWM0x:PWM7x: 8-bit PWM value individually for each output channel x

The ONx bits are duplicated in the output control register #8, in order to control the outputs with either the CHx control register or the output control register. The PRS1x:PRS0x prescaler settings can be set in the prescaler settings register #12-1 and #12-2.

The following changes of the duty cycle are performed asynchronous (with pos. edge of CSB signal):

- turn on with 100% duty cycle (CHx = ON)
- change of duty cycle value to 100%
- turn off (CHx = OFF)
- phase setting (PH0x:PH1x)
- prescaler setting (PRS1x:PRS0x)

A change in phase setting or prescaler setting during CHx = ON may cause an unwanted long on-time. Therefore it is recommended to turn off the output(s) before execution of this change.

The following changes of the duty cycle are performed synchronous (with the next PWM cycle):

- turn on with less than 100% duty cycle (OUTx = ONx)
- change of duty cycle value to less than 100%

A change of the duty cycle value can be achieved by a change of the:

- PWM0x:PWM7x bits in individual channel control register #2:#7
- GPWM EN1:GPWM EN6 bits (change between individual PWM and global PWM settings) in global PWM control register #9-1
- incremental/decremental register #14

The synchronisation of the switching phases between different devices is provided by the PWM SYNC bit in the initialization 2 register #1.

On the SPI write into initialization 2 register (#1):

- initialization when the bit D1 (PWM SYNC) is logic[1], all counters of the PWM module are reset with the positive edge of CSB, i.e. the phase synchronization is performed immediately within one SPI frame. It could help to synchronize different 12XS6 devices in the board
- when the bit D1 is logic[0], no action is executed

The switching frequency can be adjusted for the corresponding channel as described in the table below:

CLK freq. (kHz)		Prescaler setting		Divider factor	PWM freq. (Hz)		slew rate	PWM resolution)	
min.	max.	PRS1x	PRS0x		min.	max.		(Bit)	(steps)
25.6	102.4	0	0	4	25	100	slow	8	256
		0	1	2	50	200	slow		
		1	X	1	100	400	fast		

No PWM feature is provided in case of:

- Fail mode
- clock input signal failure

### 6.1.2.2 Global PWM Control

In addition to the individual PWM register, each channel can be assigned independently to a global PWM register.

The setting is controlled by the GPWM EN bits inside the global PWM control register #9-1. When no control by direct input pin is enabled and the GPWM EN bit is:

- low (logic[0]), the output is assigned to individual PWM (default status)
- high (logic[1]), the output is assigned to global PWM

The PWM value of the global PWM channel is controlled by the global PWM control register #9-2.

**Table 8. Global PWM register**

ONx	INEN1x	INEN0x	GPWM ENx	INx = 0		INx = 1	
				CHx	PWMx	CHx	PWMx
0	x	x	x	OFF	x	OFF	x
1	0	0	0	ON	individual	ON	individual
			1	ON	global	ON	global
	0	1	0	OFF	individual	ON	individual
			1	OFF	global	ON	global
	1	1	0	ON	individual	ON	global
			1	ON	global	ON	individual

When a channel is assigned to global PWM, the switching phase the prescaler and the pulse skipping are according the corresponding output channel setting.

### 6.1.2.3 Incremental PWM control

To reduce the control overhead during soft start/stop of bulbs (e.g. theatre dimming), an incremental PWM control feature is implemented. With the incremental PWM control feature, the PWM values of all internal channels OUT1:OUT5 can be incremented or decremented with one SPI frame. The incremental PWM feature is not available for:

- the global PWM channel
- the external channel OUT6

The control is according the increment/decrement register #14:

- INCR SGN: sign of incremental dimming (valid for all channels)
- INCR 1x, INCR 0x increment/decrement

***INCR SGN increment/decrement***

0	<i>decrement</i>
1	<i>increment</i>

***INCR 1x INCR 0x increment/decrement***

0	0	<i>no increment/decrement</i>
0	1	4
1	0	8
1	1	16

This feature limits the duty cycle to the rails (00 resp. FF) in order to avoid any overflow.

### 6.1.2.4 Pulse skipping

Due to the output pulse shaping feature and the thereof resulting switching delay time of the smart switches, duty cycles close to 0% resp. 100% can not be generated by the device. Therefore the pulse skipping feature (PSF) is integrated to interpolate this output duty cycle range in normal mode. The pulse skipping provides a fixed duty cycle pattern with eight states to interpolate the duty cycle values between F7 (Hex) and FF (Hex). The range between 00 (Hex) and 07 (Hex) is not considered to be provided.

The pulse skipping feature:

- is available individually for the power output channels (OUT1:OUT5)
- is not available for the external channel (OUT6)

The feature is enabled with the PSF bits in the output control register #8.

When the corresponding PSF bit is:

- low (logic[0]), the pulse skipping feature is disabled on this channel (default status)
- high (logic[1]), the pulse skipping feature is enabled on this channel



PWM duty cycle			pulse skipping frame							
hex	dec	[%]	S0	S1	S2	S3	S4	S5	S6	S7
<b>FF</b>	256	<b>100,00%</b>	FF	FF	FF	FF	FF	FF	FF	FF
<b>FE</b>	255	<b>99,61%</b>	F7	FF	FF	FF	FF	FF	FF	FF
<b>FD</b>	254	<b>99,22%</b>	F7	FF	FF	FF	F7	FF	FF	FF
<b>FC</b>	253	<b>98,83%</b>	F7	FF	F7	FF	F7	FF	FF	FF
<b>FB</b>	252	<b>98,44%</b>	F7	FF	F7	FF	F7	FF	F7	FF
<b>FA</b>	251	<b>98,05%</b>	F7	F7	F7	FF	F7	FF	F7	FF
<b>F9</b>	250	<b>97,66%</b>	F7	F7	F7	FF	F7	F7	F7	FF
<b>F8</b>	249	<b>97,27%</b>	F7	F7	F7	F7	F7	F7	F7	FF
<b>F7</b>	248	<b>96,88%</b>								
<b>F6</b>	247	<b>96,48%</b>								
<b>F5</b>	246	<b>96,09%</b>								
<b>F4</b>	245	<b>95,70%</b>								
.	.	.								
.	.	.								
.	.	.								
.	.	.								
<b>03</b>	4	<b>1,56%</b>								
<b>02</b>	3	<b>1,17%</b>								
<b>01</b>	2	<b>0,78%</b>								
<b>00</b>	1	<b>0,39%</b>								

### 6.1.2.5 Input control

Up to four dedicated control inputs (IN1:IN4) are foreseen to:

- wake-up the device
- fully control the corresponding output in case of fail mode
- control the corresponding output in case of normal mode

The control during normal mode is according the INEN0x and INEN1x bits in the input enable register #11. See [Table 8](#).

An input deglitcher is provided at each control input in order to avoid high frequency control of the outputs. The internal signal is called iINx.

The channel control (CHx) can be summarized:

- Normal mode:
  - CH1: 4 controlled by ONx or INx (if it is programmed by the SPI)
  - CH5: 6 controlled by ONx
  - Rising CHx by definition means starting overcurrent window for OUT1:5
- Fail mode:
  - CH1: 4 controlled by iINx, while the overcurrent windows are controlled by IN\_ONx
  - CH5: 6 are off

The input thresholds are logic level compatible, so the input structure of the pins are able to withstand battery voltage level (max. 40 V) without damage. External current limit resistors (i.e. 1.0 kΩ:10 kΩ) can be used to handle reverse current conditions.

The inputs have an integrated pull-down resistor.

## 6.1.2.6 Electrical characterization

**Table 9. Electrical characteristics**

Characteristics noted under conditions  $7.0\text{ V} \leq V_{\text{BAT}} \leq 18\text{ V}$ ,  $-40\text{ }^\circ\text{C} \leq T_{\text{A}} \leq 125\text{ }^\circ\text{C}$ ,  $\text{GND} = 0\text{ V}$ , unless otherwise noted. Typical values noted reflect the approximate parameter means at  $T_{\text{A}} = 25\text{ }^\circ\text{C}$  under nominal conditions, unless otherwise noted.

Symbol	Characteristic	Min.	Typ.	Max.	Unit	Notes
<b>Power outputs OUT1:OUT5</b>						
$R_{\text{DS(on)}}$	On-resistance, drain-to-source <ul style="list-style-type: none"> <li><math>T_{\text{J}} = 25\text{ }^\circ\text{C}</math></li> <li><math>T_{\text{J}} = 150\text{ }^\circ\text{C}</math></li> <li><math>T_{\text{J}} = 25\text{ }^\circ\text{C}</math>, <math>V_{\text{BAT}} = -12\text{ V}</math></li> <li><math>T_{\text{J}} = 150\text{ }^\circ\text{C}</math>, <math>V_{\text{BAT}} = -12\text{ V}</math></li> </ul>	–	32	–	m $\Omega$	
$I_{\text{LEAK SLEEP}}$	Sleep mode output leakage current (output shorted to GND) per channel <ul style="list-style-type: none"> <li><math>T_{\text{J}} = 25\text{ }^\circ\text{C}</math>, <math>V_{\text{BAT}} = 12\text{ V}</math></li> <li><math>T_{\text{J}} = 125\text{ }^\circ\text{C}</math>, <math>V_{\text{BAT}} = 12\text{ V}</math></li> <li><math>T_{\text{J}} = 25\text{ }^\circ\text{C}</math>, <math>V_{\text{BAT}} = 35\text{ V}</math></li> <li><math>T_{\text{J}} = 125\text{ }^\circ\text{C}</math>, <math>V_{\text{BAT}} = 35\text{ V}</math></li> </ul>	–	–	0.5	$\mu\text{A}$	
$I_{\text{OUT OFF}}$	Operational output leakage current in off-state per channel <ul style="list-style-type: none"> <li><math>T_{\text{J}} = 25\text{ }^\circ\text{C}</math>, <math>V_{\text{BAT}} = 18\text{ V}</math></li> <li><math>T_{\text{J}} = 125\text{ }^\circ\text{C}</math>, <math>V_{\text{BAT}} = 18\text{ V}</math></li> </ul>	–	–	10	$\mu\text{A}$	
$\delta_{\text{PWM}}$	Output PWM duty cycle range (measured at $V_{\text{OUT}} = V_{\text{BAT}/2}$ ) <ul style="list-style-type: none"> <li>Low frequency range (25 Hz to 100 Hz)</li> <li>Medium frequency range (50 Hz to 200 Hz)</li> <li>High frequency range (100 Hz to 400 Hz)</li> </ul>	4.0	–	252	LSB	
SR	Rising and falling edges slew rate at $V_{\text{BAT}} = 14\text{ V}$ (measured from $V_{\text{OUT}} = 2.5\text{ V}$ to $V_{\text{BAT}} - 2.5\text{ V}$ ) <ul style="list-style-type: none"> <li>Low frequency range</li> <li>Medium frequency range</li> <li>High frequency range</li> </ul>	0.35	0.6	0.85	V/ $\mu\text{s}$	(16)
$\Delta\text{SR}$	Rising and falling edges slew rate matching at $V_{\text{BAT}} = 14\text{ V}$ ( $\text{SRr}/\text{SRf}$ )	0.8	1.0	1.1		(16)
$t_{\text{DLY}}$	Turn-on and turn-off delay times at $V_{\text{BAT}} = 14\text{ V}$ <ul style="list-style-type: none"> <li>Low frequency range</li> <li>Medium frequency range</li> <li>High frequency range</li> </ul>	20	50	80	$\mu\text{s}$	(16)
$\Delta t_{\text{DLY}}$	Turn-on and turn-off delay times matching at $V_{\text{BAT}} = 14\text{ V}$ <ul style="list-style-type: none"> <li>Low frequency range</li> <li>Medium frequency range</li> <li>High frequency range</li> </ul>	-20	–	20	$\mu\text{s}$	(16)
$t_{\text{OUTPUT SD}}$	Shutdown delay time in case of fault	0.5	2.5	4.5	$\mu\text{s}$	
<b>Reference PWM clock</b>						
$f_{\text{CLK}}$	Clock input frequency range	25.6	–	102.4	kHz	

**Notes**

16. With nominal resistive load 5.0  $\Omega$ .

## 6.1.3 Output protections

The power outputs are protected against fault conditions in normal and fail mode in case of:

- overload conditions
- harness short-circuit
- overcurrent protection against ultra-low resistive short-circuit conditions due to smart overcurrent profile and severe short-circuit protection
- overtemperature protection including overtemperature warning
- under and overvoltage protections
- charge pump monitoring
- reverse battery protection

If a fault condition is detected, the corresponding output is commanded off immediately after the deglitch time  $t_{\text{FAULT SD}}$ .

The turn off in case of a fault shutdown (OCHI1, OCHI2, OCHI3, OCLO, OTS, UV, CPF, OLOFF) is provided by the FTO feature (fast turn off).

The FTO:

- does not use edge shaping
- is provided with high slew rate to minimize the output turn-off time  $t_{\text{OUTPUT SD}}$ , in regards to the detected fault
- uses a latch, which keeps the FTO active during an undervoltage condition ( $0 \leq V_{\text{BAT}} \leq V_{\text{BAT UVF}}$ )

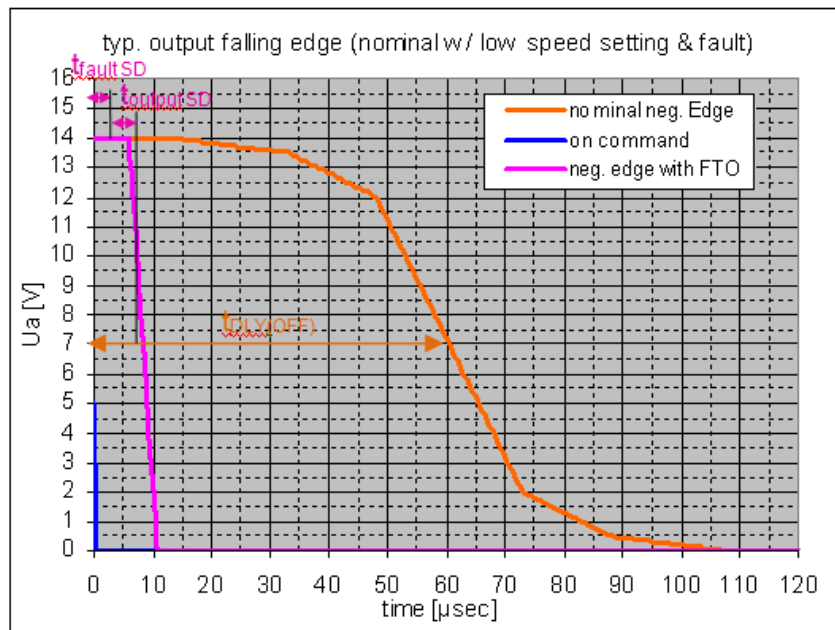

Figure 10. Power output switching in nominal operation and in case of fault

Normal mode

In case of a fault condition during normal mode:

- the status is reported in the quick status register #1 and the corresponding channel status register #2:#6.

To restart the output:

- the channel must be restarted by writing the corresponding on bit in the channel control register #2:#6 or output control register #8