



Chipsmall Limited consists of a professional team with an average of over 10 year of expertise in the distribution of electronic components. Based in Hongkong, we have already established firm and mutual-benefit business relationships with customers from,Europe,America and south Asia,supplying obsolete and hard-to-find components to meet their specific needs.

With the principle of "Quality Parts,Customers Priority,Honest Operation,and Considerate Service",our business mainly focus on the distribution of electronic components. Line cards we deal with include Microchip,ALPS,ROHM,Xilinx,Pulse,ON,Everlight and Freescale. Main products comprise IC,Modules,Potentiometer,IC Socket,Relay,Connector.Our parts cover such applications as commercial,industrial, and automotives areas.

We are looking forward to setting up business relationship with you and hope to provide you with the best service and solution. Let us make a better world for our industry!



Contact us

Tel: +86-755-8981 8866 Fax: +86-755-8427 6832

Email & Skype: info@chipsmall.com Web: www.chipsmall.com

Address: A1208, Overseas Decoration Building, #122 Zhenhua RD., Futian, Shenzhen, China



MC74HC161A, MC74HC163A



ON Semiconductor®

<http://onsemi.com>

Presettable Counters

High-Performance Silicon-Gate CMOS

The MC74HC161A and HC163A are identical in pinout to the LS161 and LS163. The device inputs are compatible with standard CMOS outputs; with pullup resistors, they are compatible with LSTTL outputs.

The HC161A and HC163A are programmable 4-bit binary counters with asynchronous and synchronous reset, respectively.

Features

- Output Drive Capability: 10 LSTTL Loads
- Outputs Directly Interface to CMOS, NMOS, and TTL
- Operating Voltage Range: 2.0 to 6.0 V
- Low Input Current: 1.0 μ A
- High Noise Immunity Characteristic of CMOS Devices
- In Compliance with the Requirements Defined by JEDEC Standard No. 7A
- Chip Complexity: 192 FETs or 48 Equivalent Gates
- Pb-Free Packages are Available*

MARKING DIAGRAMS

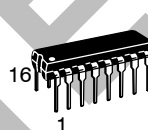

PDIP-16
N SUFFIX
CASE 648

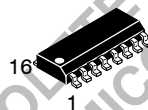

SOIC-16
D SUFFIX
CASE 751B

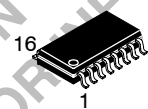
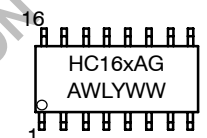

SOEIAJ-16
F SUFFIX
CASE 966

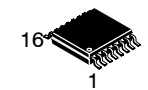
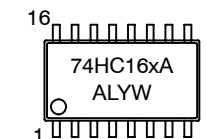

TSSOP-16
DT SUFFIX
CASE 948F

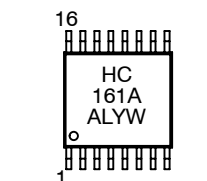

- x = 1 or 3
- A = Assembly Location
- WL, L = Wafer Lot
- Y, YY = Year
- W, WW = Work Week
- G = Pb-Free Package

ORDERING INFORMATION

See detailed ordering and shipping information in the package dimensions section on page 13 of this data sheet.

*For additional information on our Pb-Free strategy and soldering details, please download the ON Semiconductor Soldering and Mounting Techniques Reference Manual, SOLDERRM/D.

MC74HC161A, MC74HC163A

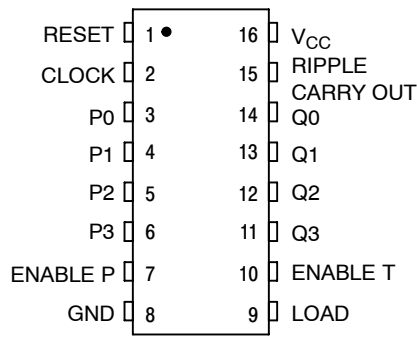

FUNCTION TABLE

Inputs					Output Q
Clock	Reset*	Load	Enable P	Enable T	
↘	L	X	X	X	Reset
↘	H	L	X	X	Load Preset Data
↘	H	H	H	H	Count
↘	H	H	L	X	No Count
↘	H	H	X	L	No Count

*HC163A only. HC161A is an Asynchronous Reset Device
 H = high level, L = low level, X = don't care

Figure 1. Pin Assignment

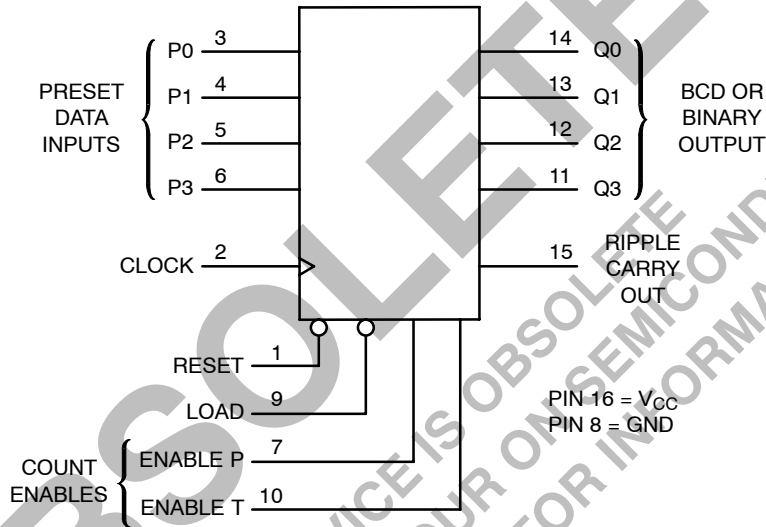

Figure 2. Logic Diagram

DEVICE/MODE TABLE

Device	Count Mode	Reset Mode
HC161A	Binary	Asynchronous
HC163A	Binary	Synchronous

MC74HC161A, MC74HC163A

MAXIMUM RATINGS

Symbol	Parameter	Value	Unit	
V _{CC}	DC Supply Voltage	-0.5 to +7.0	V	
V _I	DC Input Voltage	-0.5 to V _{CC} + 0.5	V	
V _O	DC Output Voltage (Note 1)	-0.5 ≤ V _O ≤ V _{CC} + 0.5	V	
I _{IK}	DC Input Diode Current	±20	mA	
I _{OK}	DC Output Diode Current	±25	mA	
I _O	DC Output Sink Current	±25	mA	
I _{CC}	DC Supply Current per Supply Pin	±50	mA	
I _{GND}	DC Ground Current per Ground Pin	±50	mA	
T _{STG}	Storage Temperature Range	-65 to +150	°C	
T _L	Lead Temperature, 1 mm from Case for 10 Seconds	260	°C	
T _J	Junction Temperature Under Bias	+150	°C	
θ _{JA}	Thermal Resistance	PDIP SOIC TSSOP	78 112 148	°C/W
P _D	Power Dissipation in Still Air at 85°C	PDIP SOIC TSSOP	750 500 450	mW
MSL	Moisture Sensitivity		Level 1	
F _R	Flammability Rating	Oxygen Index: 30% - 35%	UL 94 V-0 @ 0.125 in	
V _{ESD}	ESD Withstand Voltage	Human Body Model (Note 2) Machine Model (Note 3) Charged Device Model (Note 4)	> 2000 > 200 > 1000	V
I _{LATCHUP}	Latchup Performance	Above V _{CC} and Below GND at 85°C (Note 5)	±300	mA

Stresses exceeding Maximum Ratings may damage the device. Maximum Ratings are stress ratings only. Functional operation above the Recommended Operating Conditions is not implied. Extended exposure to stresses above the Recommended Operating Conditions may affect device reliability.

1. I_O absolute maximum rating must be observed.
2. Tested to EIA/JESD22-A114-A.
3. Tested to EIA/JESD22-A115-A.
4. Tested to JESD22-C101-A.
5. Tested to EIA/JESD78.

RECOMMENDED OPERATING CONDITIONS

Symbol	Parameter	Min	Max	Unit
V _{CC}	DC Supply Voltage (Referenced to GND)	2.0	6.0	V
V _{in} , V _{out}	DC Input Voltage, Output Voltage (Referenced to GND)	0	V _{CC}	V
T _A	Operating Temperature, All Package Types	-55	+125	°C
t _p , t _f	Input Rise and Fall Time (Figure 4)	V _{CC} = 2.0 V V _{CC} = 3.0 V V _{CC} = 4.5 V V _{CC} = 6.0 V	0 1000 600 500 400	ns

6. Unused inputs may not be left open. All inputs must be tied to a high- or low-logic input voltage level.

MC74HC161A, MC74HC163A

DC ELECTRICAL CHARACTERISTICS (Voltages Referenced to GND)

Symbol	Parameter	Test Conditions	V _{CC} V	Guaranteed Limit			Unit
				-55 to 25°C	≤ 85°C	≤ 125°C	
V _{IH}	Minimum High-Level Input Voltage	V _{out} = 0.1 V or V _{CC} - 0.1 V I _{out} ≤ 20 μA	2.0	1.5	1.5	1.5	V
			3.0	2.1	2.1	2.1	
			4.5	3.15	3.15	3.15	
			6.0	4.2	4.2	4.2	
V _{IL}	Maximum Low-Level Input Voltage	V _{out} = 0.1 V or V _{CC} - 0.1 V I _{out} ≤ 20 μA	2.0	0.5	0.5	0.5	V
			3.0	0.9	0.9	0.9	
			4.5	1.35	1.35	1.35	
			6.0	1.8	1.8	1.8	
V _{OH}	Minimum High-Level Output Voltage	V _{in} = V _{IH} or V _{IL} I _{out} ≤ 20 μA	2.0	1.9	1.9	1.9	V
			4.5	4.4	4.4	4.4	
			6.0	5.9	5.9	5.9	
		V _{in} = V _{IH} or V _{IL} I _{out} ≤ 3.6 mA I _{out} ≤ 4.0 mA I _{out} ≤ 5.2 mA	3.0	2.48	2.34	2.2	
			4.5	3.98	3.84	3.7	
			6.0	5.48	5.34	5.2	
V _{OL}	Maximum Low-Level Output Voltage	V _{in} = V _{IH} or V _{IL} I _{out} ≤ 20 μA	2.0	0.1	0.1	0.1	V
			4.5	0.1	0.1	0.1	
			6.0	0.1	0.1	0.1	
		V _{in} = V _{IH} or V _{IL} I _{out} ≤ 3.6 mA I _{out} ≤ 4.0 mA I _{out} ≤ 5.2 mA	3.0	0.26	0.33	0.4	
			4.5	0.26	0.33	0.4	
			6.0	0.26	0.33	0.4	
I _{in}	Maximum Input Leakage Current	V _{in} = V _{CC} or GND	6.0	±0.1	±1.0	±1.0	μA
I _{CC}	Maximum Quiescent Supply Current	V _{in} = V _{CC} or GND I _{out} = 0 μA	6.0	4.0	40	160	μA

7. Information on typical parametric values can be found in the ON Semiconductor High-Speed CMOS Data Book (DL129/D).

OBSOLETE
THIS DEVICE IS OBSOLETE
PLEASE CONTACT YOUR ONSEMI REPRESENTATIVE FOR INFORMATION

MC74HC161A, MC74HC163A

AC ELECTRICAL CHARACTERISTICS (C_L = 50 pF, Input t_r = t_f = 6.0 ns)

Symbol	Parameter	Figure	V _{CC} V	Guaranteed Limit			Unit
				- 55 to 25 °C	≤ 85 °C	≤ 125 °C	
f _{max}	Maximum Clock Frequency (50% Duty Cycle) (Note 8)	4, 10	2.0	6	5	4	MHz
			3.0	15	12	10	
			4.5	30	24	20	
			6.0	35	28	24	
t _{PLH}	Maximum Propagation Delay, Clock to Q	4, 10	2.0	120	160	200	ns
			3.0	75	120	150	
			4.5	20	23	28	
			6.0	16	20	22	
t _{PHL}		4, 10	2.0	145	185	220	ns
			3.0	100	135	150	
			4.5	22	25	30	
			6.0	18	20	23	
t _{PHL}	Maximum Propagation Delay, Reset to Q (HC161A Only)	5, 10	2.0	145	185	220	ns
			3.0	100	135	150	
			4.5	20	22	25	
			6.0	17	19	21	
t _{PLH}	Maximum Propagation Delay, Enable T to Ripple Carry Out	6, 10	2.0	110	150	190	ns
			3.0	60	115	140	
			4.5	16	18	20	
			6.0	14	15	17	
t _{PHL}		6, 10	2.0	135	175	210	ns
			3.0	100	130	160	
			4.5	18	20	22	
			6.0	15	16	20	
t _{PLH}	Maximum Propagation Delay, Clock to Ripple Carry Out	4, 10	2.0	120	160	200	ns
			3.0	75	135	150	
			4.5	22	27	30	
			6.0	18	22	25	
t _{PHL}		4, 10	2.0	145	185	220	ns
			3.0	100	135	150	
			4.5	22	28	35	
			6.0	20	24	28	
t _{PHL}	Maximum Propagation Delay, Reset to Ripple Carry Out (HC161A Only)	5, 10	2.0	155	190	230	ns
			3.0	120	140	155	
			4.5	22	26	30	
			6.0	18	22	25	
t _{TLH} , t _{THL}	Maximum Output Transition Time, Any Output	5, 10	2.0	75	95	110	ns
			3.0	30	40	55	
			4.5	15	19	22	
			6.0	13	16	19	
C _{in}	Maximum Input Capacitance	4, 10	-	10	10	10	pF

8. Applies to noncascaded/nonsynchronous clocked configurations only with synchronously cascaded counters. (1) Clock to Ripple Carry Out propagation delays. (2) Enable T or Enable P to Clock setup times and (3) Clock to Enable T or Enable P hold times determine f_{max}. However, if Ripple Carry out of each stage is tied to the Clock of the next stage (nonsynchronously clocked) the f_{max} in the table above is applicable. See Applications information in this data sheet.

9. For propagation delays with loads other than 50 pF, and information on typical parametric values, see the ON Semiconductor High-Speed CMOS Data Book (DL129/D).

C _{PD}	Power Dissipation Capacitance (Per Gate) (Note 10)	Typical @ 25°C, V _{CC} = 5.0 V	

10. Used to determine the no-load dynamic power consumption: P_D = C_{PD} V_{CC}²f + I_{CC} V_{CC}. For load considerations, see the ON Semiconductor High-Speed CMOS Data Book (DL129/D).

MC74HC161A, MC74HC163A

TIMING REQUIREMENTS ($C_L = 50$ pF, Input $t_r = t_f = 6.0$ ns)

Symbol	Parameter	Figure	V _{CC} V	Guaranteed Limit			Unit
				- 55 to 25 °C	≤ 85 °C	≤ 125 °C	
t _{su}	Minimum Setup Time, Preset Data Inputs to Clock	8	2.0	40	60	80	ns
			3.0	20	30	40	
			4.5	15	20	30	
			6.0	12	18	20	
t _{su}	Minimum Setup Time, Load to Clock	8	2.0	60	75	90	ns
			3.0	25	30	40	
			4.5	15	20	30	
			6.0	12	18	20	
t _{su}	Minimum Setup Time, Reset to Clock (HC163A Only)	7	2.0	60	75	90	ns
			3.0	25	30	40	
			4.5	20	25	35	
			6.0	17	23	25	
t _{su}	Minimum Setup Time, Enable T or Enable P to Clock	9	2.0	80	95	110	ns
			3.0	35	40	50	
			4.5	20	25	35	
			6.0	17	23	25	
t _h	Minimum Hold Time, Clock to Load or Preset Data Inputs	8	2.0	3	3	3	ns
			3.0	3	3	3	
			4.5	3	3	3	
			6.0	3	3	3	
t _h	Minimum Hold Time, Clock to Reset (HC163A Only)	7	2.0	3	3	3	ns
			3.0	3	3	3	
			4.5	3	3	3	
			6.0	3	3	3	
t _h	Minimum Hold Time, Clock to Enable T or Enable P	9	2.0	3	3	3	ns
			3.0	3	3	3	
			4.5	3	3	3	
			6.0	3	3	3	
t _{rec}	Minimum Recovery Time, Reset Inactive to Clock (HC161A Only)	5	2.0	80	95	110	ns
			3.0	35	40	50	
			4.5	15	20	26	
			6.0	12	17	23	
t _{rec}	Minimum Recovery Time, Load Inactive to Clock	8	2.0	80	95	110	ns
			3.0	35	40	50	
			4.5	15	20	26	
			6.0	12	17	23	
t _w	Minimum Pulse Width, Clock	4	2.0	60	75	90	ns
			3.0	25	30	40	
			4.5	12	15	18	
			6.0	10	13	15	
t _w	Minimum Pulse Width, Reset (HC161A Only)	5	2.0	60	75	90	ns
			3.0	25	30	40	
			4.5	12	15	18	
			6.0	10	13	15	
t _r , t _f	Maximum Input Rise and Fall Times		2.0	1000	1000	1000	ns
			3.0	800	800	800	
			4.5	500	500	500	
			6.0	400	400	400	

MC74HC161A, MC74HC163A

FUNCTION DESCRIPTION

The HC161A/163A are programmable 4-bit synchronous counters that feature parallel Load, synchronous or asynchronous Reset, a Carry Output for cascading, and count-enable controls.

The HC161A and HC163A are binary counters with asynchronous Reset and synchronous Reset, respectively.

INPUTS

Clock (Pin 2)

The internal flip-flops toggle and the output count advances with the rising edge of the Clock input. In addition, control functions, such as resetting and loading, occur with the rising edge of the Clock input.

Preset Data Inputs P0, P1, P2, P3 (Pins 3, 4, 5, 6)

These are the data inputs for programmable counting. Data on these pins may be synchronously loaded into the internal flip-flops and appear at the counter outputs. P0 (Pin 3) is the least-significant bit and P3 (Pin 6) is the most-significant bit.

OUTPUTS

Q0, Q1, Q2, Q3 (Pins 14, 13, 12, 11)

These are the counter outputs. Q0 (Pin 14) is the least-significant bit and Q3 (Pin 11) is the most-significant bit.

Ripple Carry Out (Pin 15)

When the counter is in its maximum state, 1111, this output goes high, providing an external look-ahead carry pulse that may be used to enable successive cascaded counters. Ripple Carry Out remains high only during the maximum count state. The logic equation for this output is:

$$\text{Ripple Carry Out} = \text{Enable T} \cdot \text{Q0} \cdot \text{Q1} \cdot \text{Q2} \cdot \text{Q3}$$

OUTPUT STATE DIAGRAMS

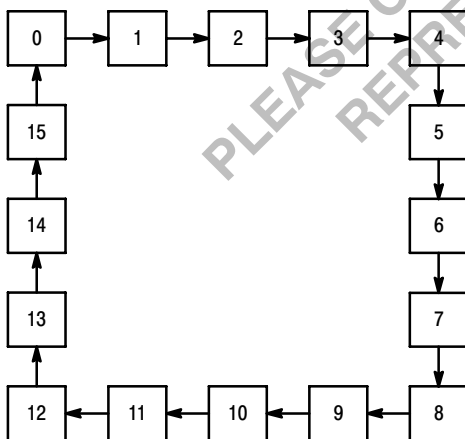

Figure 3. Binary Counters

CONTROL FUNCTIONS

Resetting

A low level on the Reset pin (Pin 1) resets the internal flip-flops and sets the outputs (Q0 through Q3) to a low level. The HC161A resets asynchronously, and the HC163A resets with the rising edge of the Clock input (synchronous reset).

Loading

With the rising edge of the Clock, a low level on Load (Pin 9) loads the data from the Preset Data input pins (P0, P1, P2, P3) into the internal flip-flops and onto the output pins, Q0 through Q3. The count function is disabled as long as Load is low.

Count Enable/Disable

These devices have two count-enable control pins: Enable P (Pin 7) and Enable T (Pin 10). The devices count when these two pins and the Load pin are high. The logic equation is:

$$\text{Count Enable} = \text{Enable P} \cdot \text{Enable T} \cdot \text{Load}$$

The count is either enabled or disabled by the control inputs according to Table 1. In general, Enable P is a count-enable control; Enable T is both a count-enable and a Ripple-Carry Output control.

Table 1. Count Enable/Disable

Control Inputs			Result at Outputs	
Load	Enable P	Enable T	Q0 - Q3	Ripple Carry Out
H	H	H	Count	High when Q0-Q3 are maximum*
L	H	H	No Count	
X	L	H	No Count	High when Q0-Q3 are maximum*
X	X	L	No Count	L

*Q0 through Q3 are maximum when Q3, Q2, Q1, Q0 = 1111.

MC74HC161A, MC74HC163A

SWITCHING WAVEFORMS

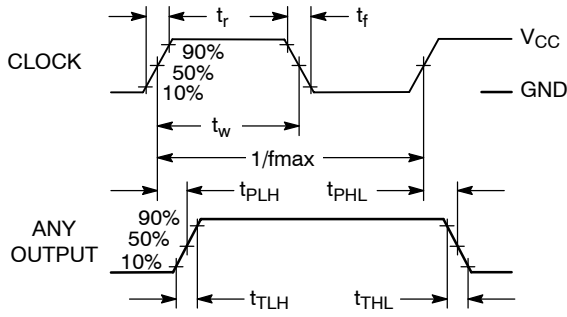

Figure 4.

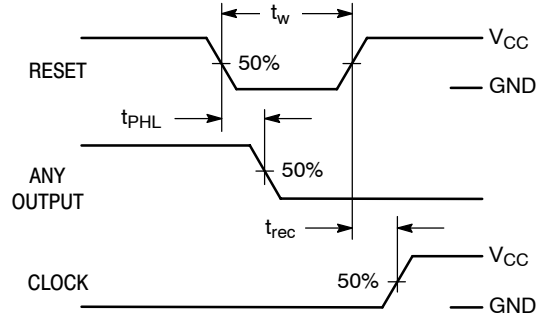

Figure 5.

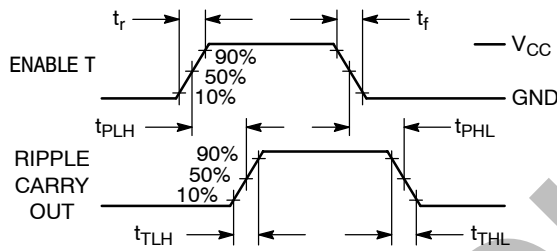

Figure 6.

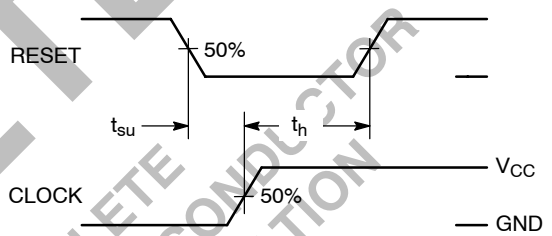

Figure 7. HC163A Only

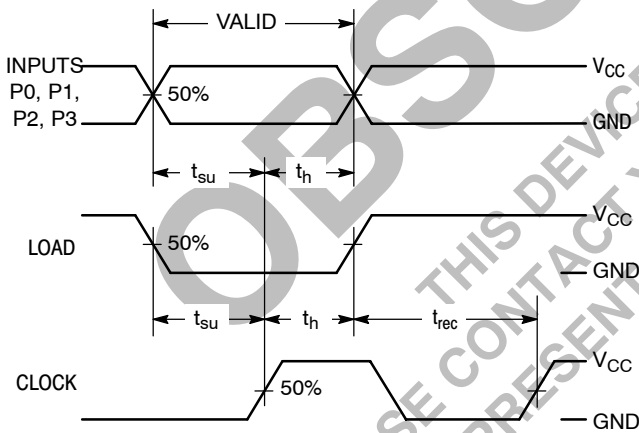

Figure 8.

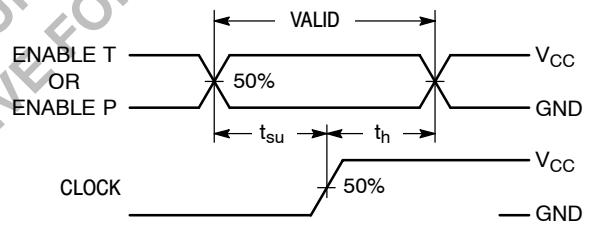
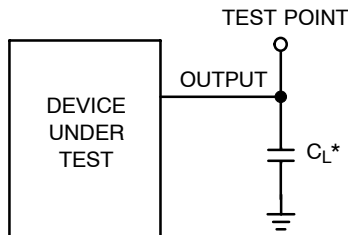

Figure 9.

TEST CIRCUIT



*Includes all probe and jig capacitance

Figure 10.

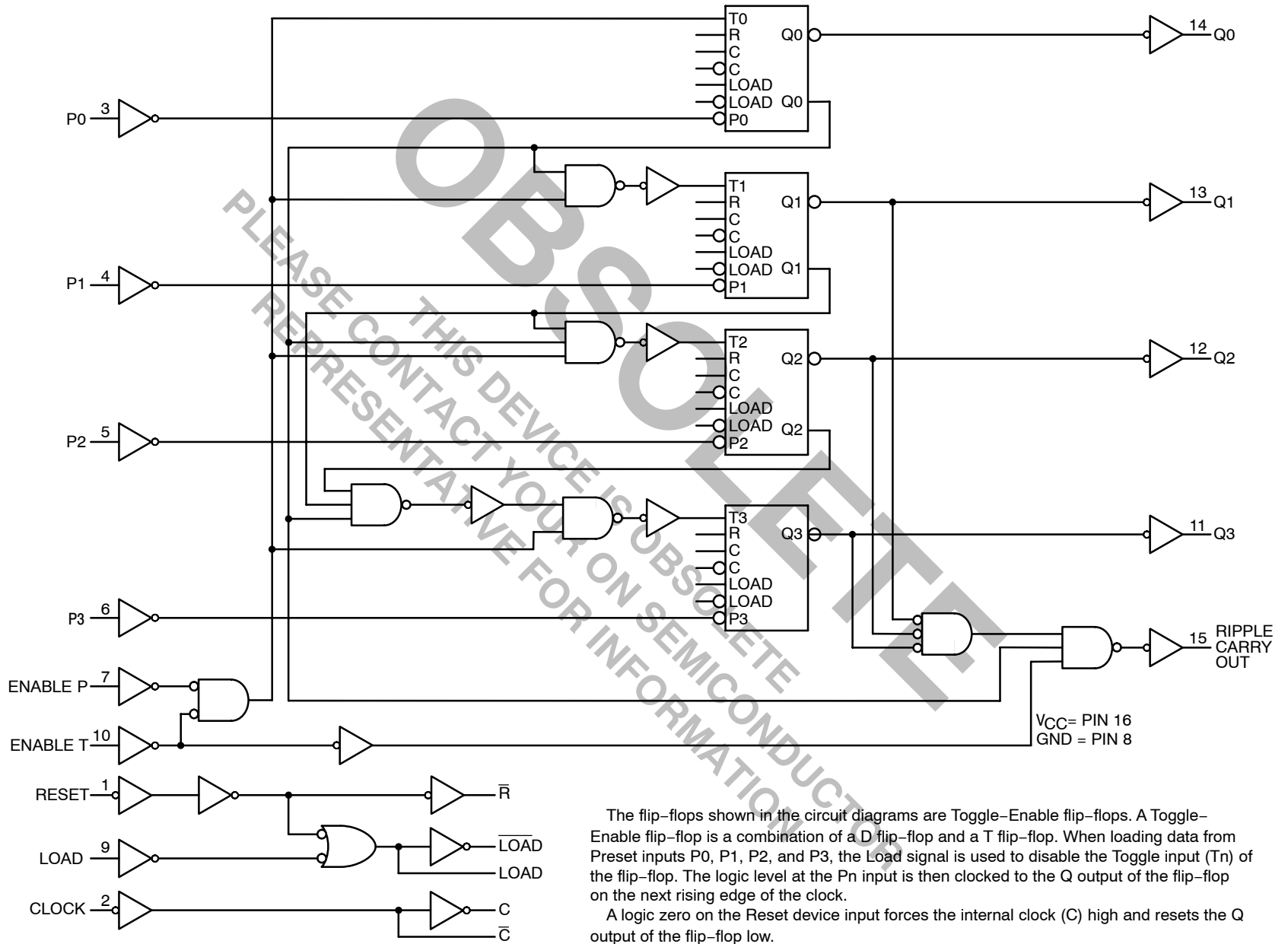

The flip-flops shown in the circuit diagrams are Toggle-Enable flip-flops. A Toggle-Enable flip-flop is a combination of a D flip-flop and a T flip-flop. When loading data from Preset inputs P0, P1, P2, and P3, the Load signal is used to disable the Toggle input (Tn) of the flip-flop. The logic level at the Pn input is then clocked to the Q output of the flip-flop on the next rising edge of the clock.

A logic zero on the Reset device input forces the internal clock (C) high and resets the Q output of the flip-flop low.

Figure 11. 4-Bit Binary Counter with Asynchronous Reset (MC74HC161A)

MC74HC161A, MC74HC163A

Sequence illustrated in waveforms:

1. Reset outputs to zero.
2. Preset to binary twelve.
3. Count to thirteen, fourteen, fifteen, zero, one and two.
4. Inhibit.

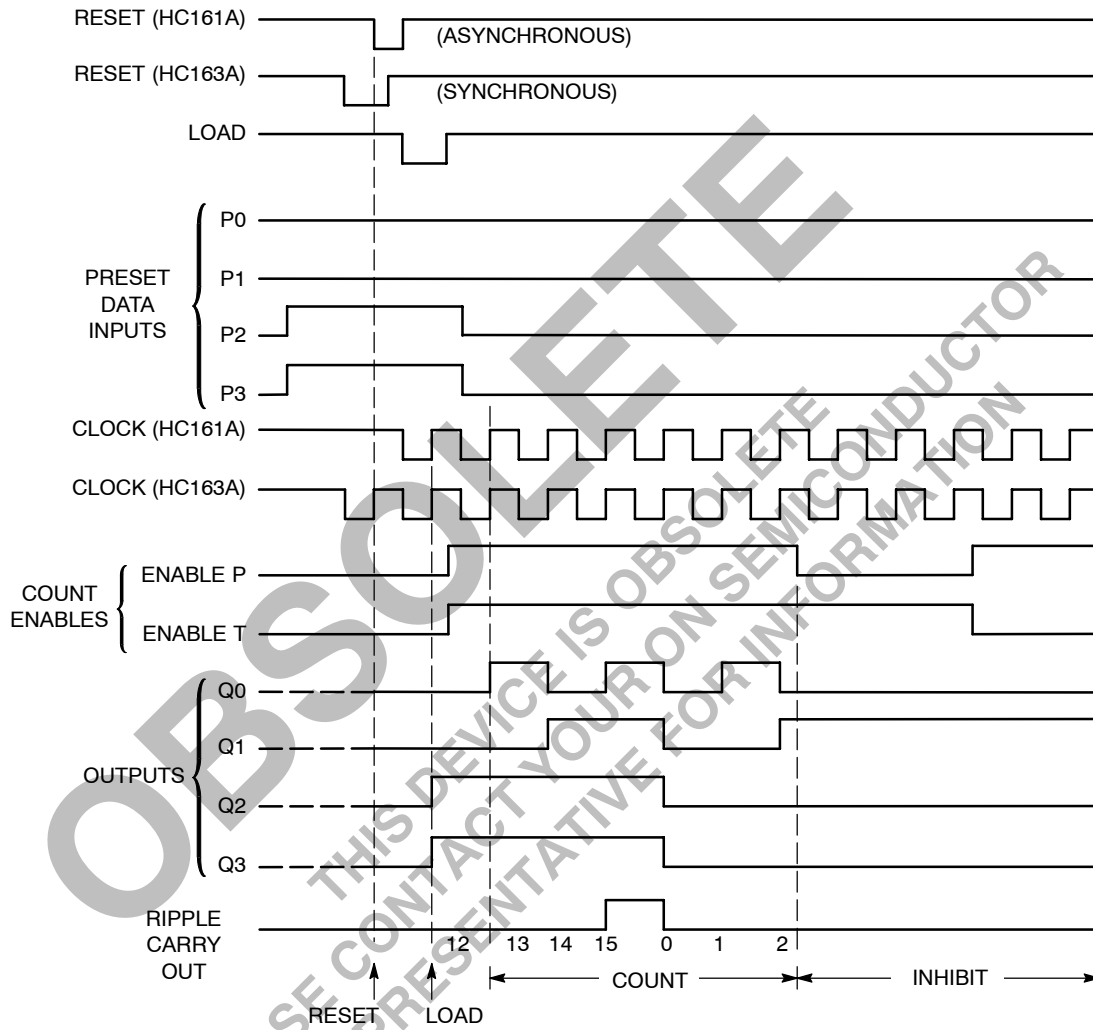
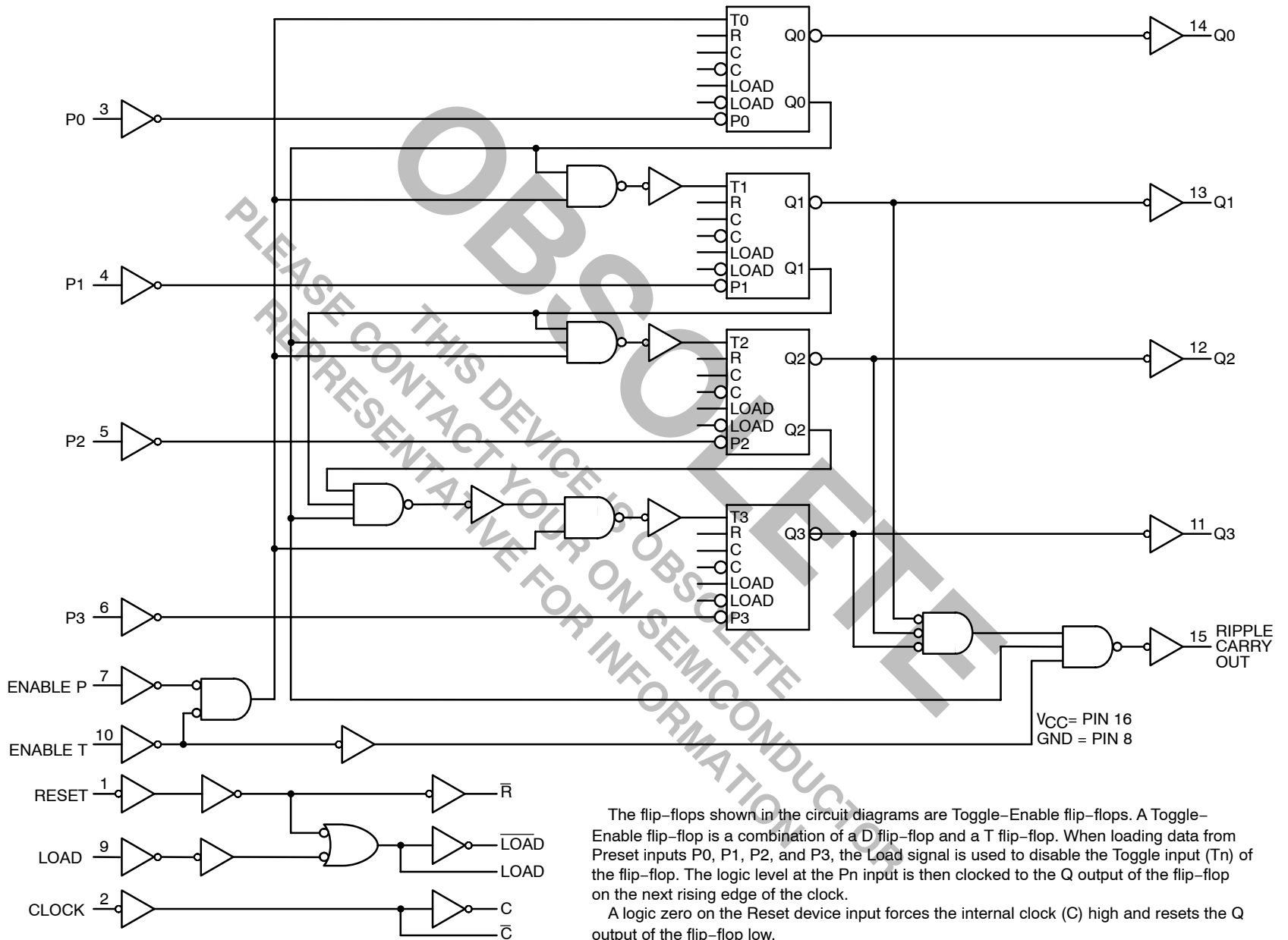

Figure 12. Timing Diagram



The flip-flops shown in the circuit diagrams are Toggle-Enable flip-flops. A Toggle-Enable flip-flop is a combination of a D flip-flop and a T flip-flop. When loading data from Preset inputs P0, P1, P2, and P3, the Load signal is used to disable the Toggle input (Tn) of the flip-flop. The logic level at the Pn input is then clocked to the Q output of the flip-flop on the next rising edge of the clock.

A logic zero on the Reset device input forces the internal clock (C) high and resets the Q output of the flip-flop low.

Figure 13. 4-Bit Binary Counter with Synchronous Reset (MC74HC163A)

MC74HC161A, MC74HC163A

TYPICAL APPLICATIONS CASCADING

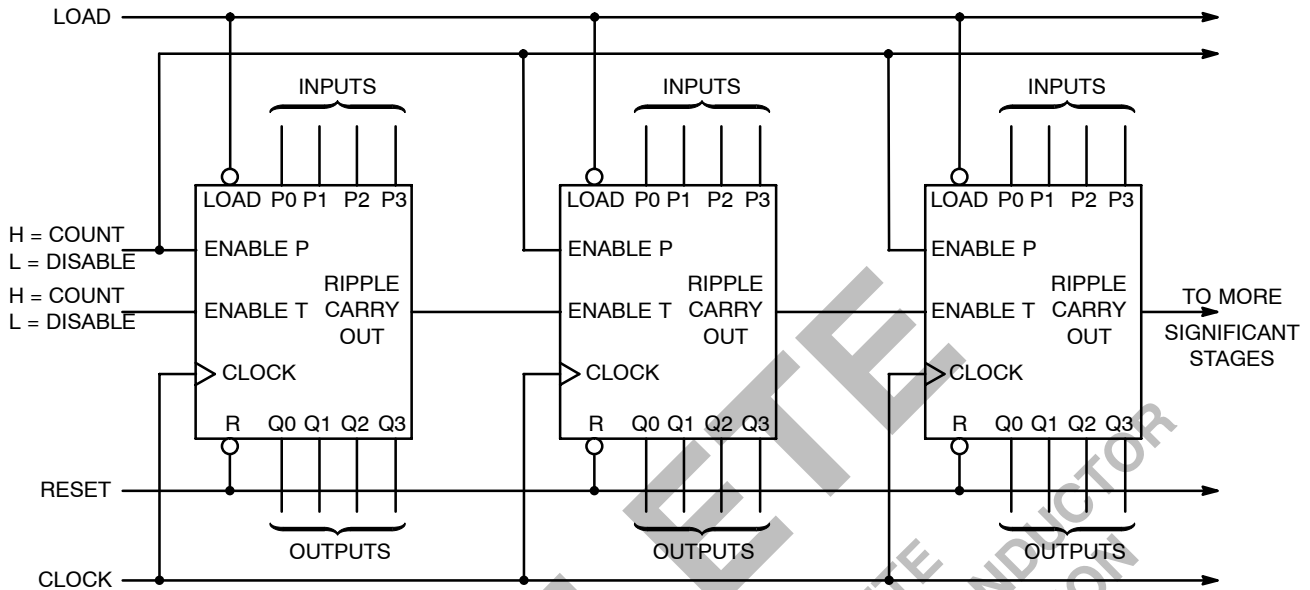

NOTE: When used in these cascaded configurations the clock f_{max} guaranteed limits may not apply. Actual performance will depend on number of stages. This limitation is due to set up times between Enable (Port) and Clock.

Figure 14. N-Bit Synchronous Counters

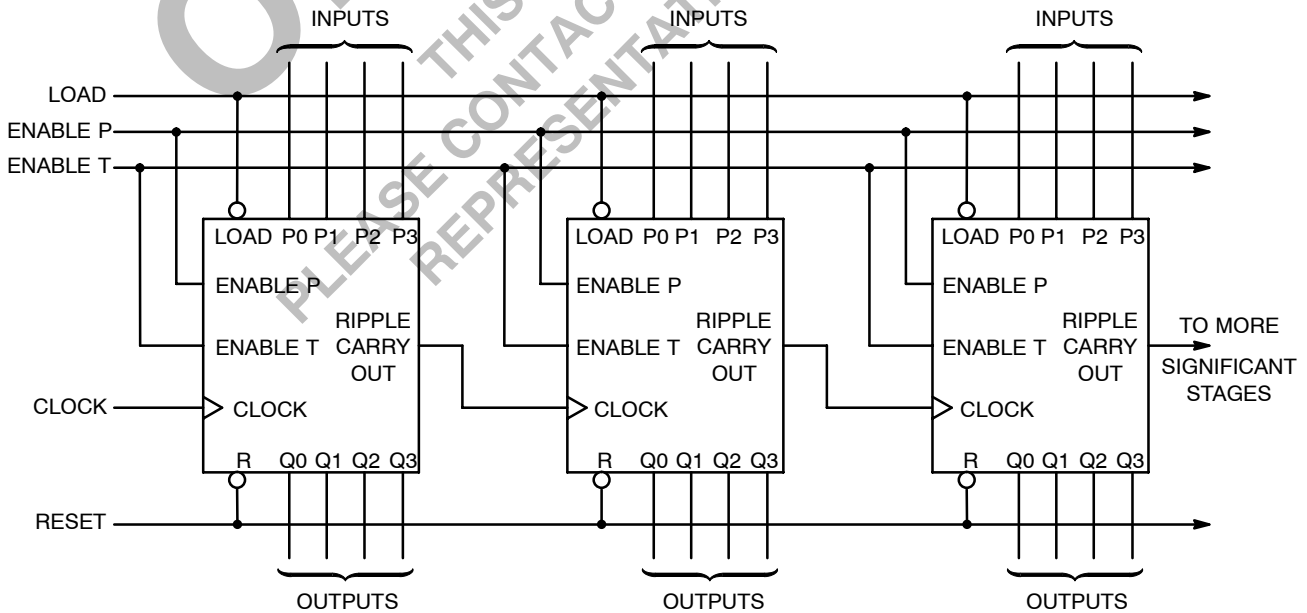

Figure 15. Nibble Ripple Counter

MC74HC161A, MC74HC163A

TYPICAL APPLICATIONS VARYING THE MODULUS

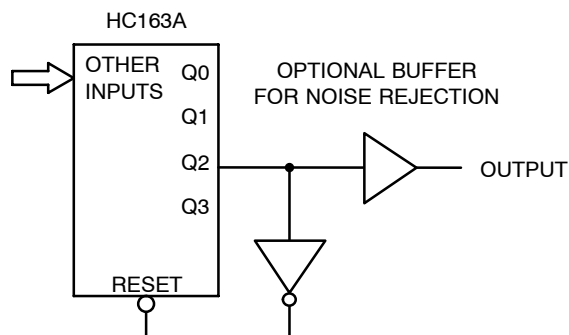

Figure 16. Modulo-5 Counter

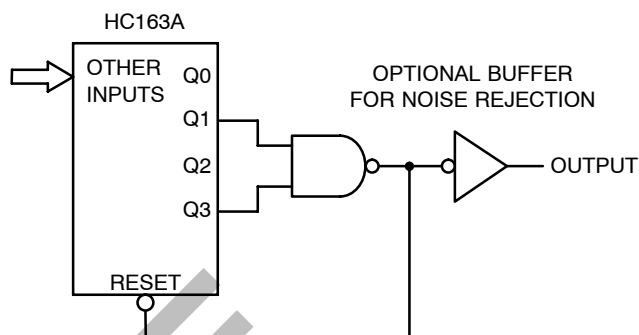

Figure 17. Modulo-11 Counter

The HC163A facilitates designing counters of any modulus with minimal external logic. The output is glitch-free due to the synchronous Reset.

ORDERING INFORMATION

Device	Package	Shipping†
MC74HC161AN	PDIP-16	500 Units / Box
MC74HC161ANG	PDIP-16 (Pb-Free)	500 Units / Box
MC74HC161AD	SOIC-16	48 Units / Rail
MC74HC161ADG	SOIC-16 (Pb-Free)	48 Units / Rail
MC74HC161ADR2	SOIC-16	2500 Units / Tape & Reel
MC74HC161ADR2G	SOIC-16 (Pb-Free)	2500 Units / Tape & Reel
MC74HC161AFEL	SOEIAJ-16	2000 Units / Tape & Reel
MC74HC161ADTR2	TSSOP-16*	2500 Units / Tape & Reel
MC74HC163AN	PDIP-16	500 Units / Box
MC74HC163ANG	PDIP-16 (Pb-Free)	500 Units / Box
MC74HC163AD	SOIC-16	48 Units / Rail
MC74HC163ADG	SOIC-16 (Pb-Free)	48 Units / Rail
MC74HC4163DR2	SOIC-16	2500 Units / Tape & Reel
MC74HC163ADR2G	SOIC-16 (Pb-Free)	2500 Units / Tape & Reel
MC74HC163AFEL	SOEIAJ-16	2000 Units / Tape & Reel

†For information on tape and reel specifications, including part orientation and tape sizes, please refer to our Tape and Reel Packaging Specifications Brochure, BRD8011/D.

*This package is inherently Pb-Free.

MC74HC161A, MC74HC163A

PACKAGE DIMENSIONS

PDIP-16
N SUFFIX
CASE 648-08
ISSUE T

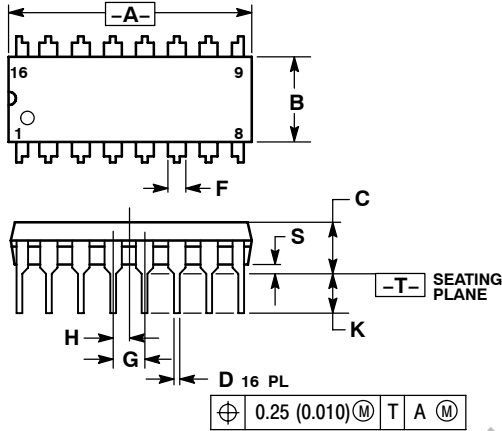

- NOTES:
1. DIMENSIONING AND TOLERANCING PER ANSI Y14.5M, 1982.
 2. CONTROLLING DIMENSION: INCH.
 3. DIMENSION L TO CENTER OF LEADS WHEN FORMED PARALLEL.
 4. DIMENSION B DOES NOT INCLUDE MOLD FLASH.
 5. ROUNDED CORNERS OPTIONAL.

DIM	INCHES		MILLIMETERS	
	MIN	MAX	MIN	MAX
A	0.740	0.770	18.80	19.55
B	0.250	0.270	6.35	6.85
C	0.145	0.175	3.69	4.44
D	0.015	0.021	0.39	0.53
F	0.040	0.70	1.02	1.77
G	0.100 BSC		2.54 BSC	
H	0.050 BSC		1.27 BSC	
J	0.008	0.015	0.21	0.38
K	0.110	0.130	2.80	3.30
L	0.295	0.305	7.50	7.74
M	0° - 10°		0° - 10°	
S	0.020	0.040	0.51	1.01

SOIC-16
D SUFFIX
CASE 751B-05
ISSUE J

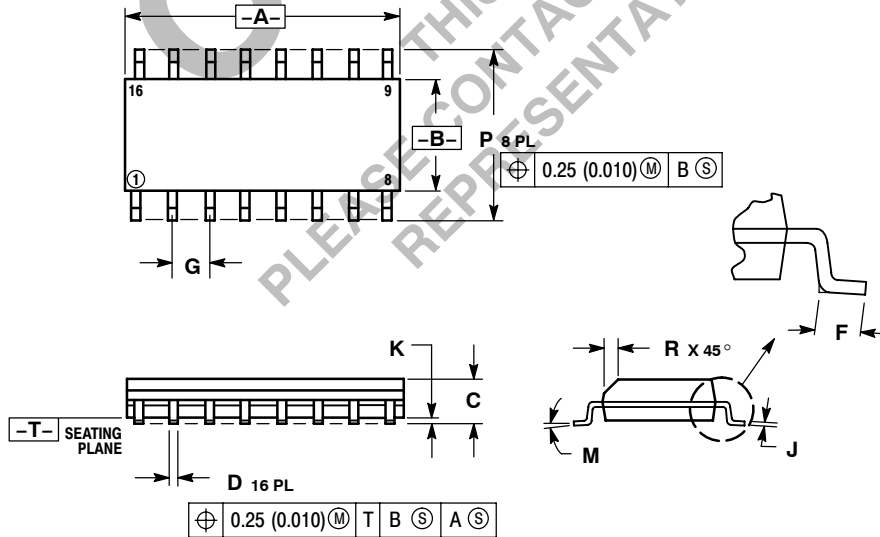

- NOTES:
1. DIMENSIONING AND TOLERANCING PER ANSI Y14.5M, 1982.
 2. CONTROLLING DIMENSION: MILLIMETER.
 3. DIMENSIONS A AND B DO NOT INCLUDE MOLD PROTRUSION.
 4. MAXIMUM MOLD PROTRUSION 0.15 (0.006) PER SIDE.
 5. DIMENSION D DOES NOT INCLUDE DAMBAR PROTRUSION. ALLOWABLE DAMBAR PROTRUSION SHALL BE 0.127 (0.005) TOTAL IN EXCESS OF THE D DIMENSION AT MAXIMUM MATERIAL CONDITION.

DIM	MILLIMETERS		INCHES	
	MIN	MAX	MIN	MAX
A	9.80	10.00	0.386	0.393
B	3.80	4.00	0.150	0.157
C	1.35	1.75	0.054	0.068
D	0.35	0.49	0.014	0.019
F	0.40	1.25	0.016	0.049
G	1.27 BSC 0.050 BSC			
J	0.19	0.25	0.008	0.009
K	0.10	0.25	0.004	0.009
M	0° - 7°			
P	5.80	6.20	0.229	0.244
R	0.25	0.50	0.010	0.019

MC74HC161A, MC74HC163A

PACKAGE DIMENSIONS

SOEIAJ-16
F SUFFIX
CASE 966-01
ISSUE O

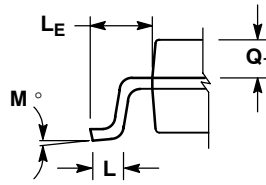
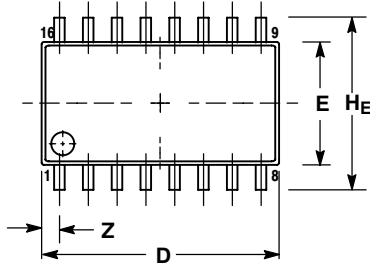

DETAIL P

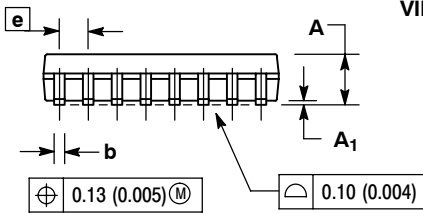

VIEW P

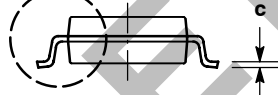

NOTES:

1. DIMENSIONING AND TOLERANCING PER ANSI Y14.5M, 1982.
2. CONTROLLING DIMENSION: MILLIMETER.
3. DIMENSIONS D AND E DO NOT INCLUDE MOLD FLASH OR PROTRUSIONS AND ARE MEASURED AT THE PARTING LINE. MOLD FLASH OR PROTRUSIONS SHALL NOT EXCEED 0.15 (0.006) PER SIDE.
4. TERMINAL NUMBERS ARE SHOWN FOR REFERENCE ONLY.
5. THE LEAD WIDTH DIMENSION (b) DOES NOT INCLUDE DAMBAR PROTRUSION. ALLOWABLE DAMBAR PROTRUSION SHALL BE 0.08 (0.003) TOTAL IN EXCESS OF THE LEAD WIDTH DIMENSION AT MAXIMUM MATERIAL CONDITION. DAMBAR CANNOT BE LOCATED ON THE LOWER RADIUS OR THE FOOT. MINIMUM SPACE BETWEEN PROTRUSIONS AND ADJACENT LEAD TO BE 0.46 (0.018).

DIM	MILLIMETERS		INCHES	
	MIN	MAX	MIN	MAX
A	---	2.05	---	0.081
A ₁	0.05	0.20	0.002	0.008
b	0.35	0.50	0.014	0.020
c	0.18	0.27	0.007	0.011
D	9.90	10.50	0.390	0.413
E	5.10	5.45	0.201	0.215
e	1.27 BSC		0.050 BSC	
H _E	7.40	8.20	0.291	0.323
L	0.50	0.85	0.020	0.033
L _E	1.10	1.50	0.043	0.059
M	0°	10°	0°	10°
Q ₁	0.70	0.90	0.028	0.035
Z	---	0.78	---	0.031

OBSOLETE

THIS DEVICE IS OBSOLETE
PLEASE CONTACT YOUR ON SEMICONDUCTOR
REPRESENTATIVE FOR INFORMATION

MC74HC161A, MC74HC163A

PACKAGE DIMENSIONS

TSSOP-16
DT SUFFIX
CASE 948F-01
ISSUE A

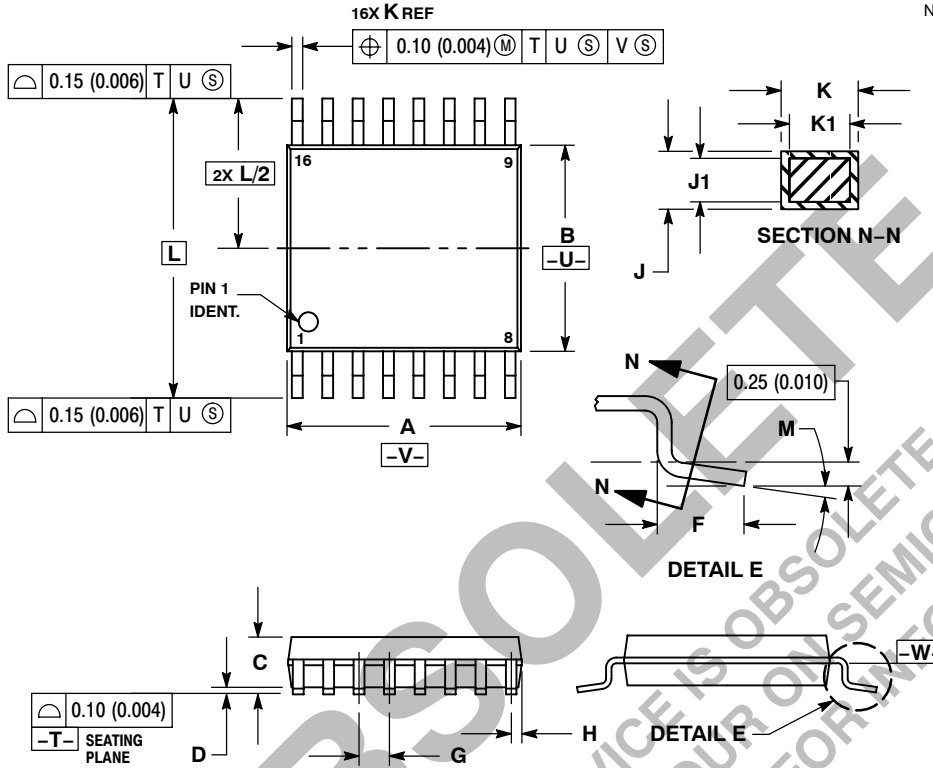

NOTES:

1. DIMENSIONING AND TOLERANCING PER ANSI Y14.5M, 1982.
2. CONTROLLING DIMENSION: MILLIMETER.
3. DIMENSION A DOES NOT INCLUDE MOLD FLASH, PROTRUSIONS OR GATE BURRS. MOLD FLASH OR GATE BURRS SHALL NOT EXCEED 0.15 (0.006) PER SIDE.
4. DIMENSION B DOES NOT INCLUDE INTERLEAD FLASH OR PROTRUSION. INTERLEAD FLASH OR PROTRUSION SHALL NOT EXCEED 0.25 (0.010) PER SIDE.
5. DIMENSION K DOES NOT INCLUDE DAMBAR PROTRUSION. ALLOWABLE DAMBAR PROTRUSION SHALL BE 0.08 (0.003) TOTAL IN EXCESS OF THE K DIMENSION AT MAXIMUM MATERIAL CONDITION.
6. TERMINAL NUMBERS ARE SHOWN FOR REFERENCE ONLY.
7. DIMENSION A AND B ARE TO BE DETERMINED AT DATUM PLANE -W-.

DIM	MILLIMETERS		INCHES	
	MIN	MAX	MIN	MAX
A	4.90	5.10	0.193	0.200
B	4.30	4.50	0.169	0.177
C	---	1.20	---	0.047
D	0.05	0.15	0.002	0.006
F	0.50	0.75	0.020	0.030
G	0.65 BSC		0.026 BSC	
H	0.18	0.28	0.007	0.011
J	0.09	0.20	0.004	0.008
J1	0.09	0.16	0.004	0.006
K	0.19	0.30	0.007	0.012
K1	0.19	0.25	0.007	0.010
L	6.40 BSC		0.252 BSC	
M	0°	8°	0°	8°

ON Semiconductor and are registered trademarks of Semiconductor Components Industries, LLC (SCILLC). SCILLC reserves the right to make changes without further notice to any products herein. SCILLC makes no warranty, representation or guarantee regarding the suitability of its products for any particular purpose, nor does SCILLC assume any liability arising out of the application or use of any product or circuit, and specifically disclaims any and all liability, including without limitation special, consequential or incidental damages. "Typical" parameters which may be provided in SCILLC data sheets and/or specifications can and do vary in different applications and actual performance may vary over time. All operating parameters, including "Typicals" must be validated for each customer application by customer's technical experts. SCILLC does not convey any license under its patent rights nor the rights of others. SCILLC products are not designed, intended, or authorized for use as components in systems intended for surgical implant into the body, or other applications intended to support or sustain life, or for any other application in which the failure of the SCILLC product could create a situation where personal injury or death may occur. Should Buyer purchase or use SCILLC products for any such unintended or unauthorized application, Buyer shall indemnify and hold SCILLC and its officers, employees, subsidiaries, affiliates, and distributors harmless against all claims, costs, damages, and expenses, and reasonable attorney fees arising out of, directly or indirectly, any claim of personal injury or death associated with such unintended or unauthorized use, even if such claim alleges that SCILLC was negligent regarding the design or manufacture of the part. SCILLC is an Equal Opportunity/Affirmative Action Employer. This literature is subject to all applicable copyright laws and is not for resale in any manner.

PUBLICATION ORDERING INFORMATION

LITERATURE FULFILLMENT:
Literature Distribution Center for ON Semiconductor
P.O. Box 5163, Denver, Colorado 80217 USA
Phone: 303-675-2175 or 800-344-3860 Toll Free USA/Canada
Fax: 303-675-2176 or 800-344-3867 Toll Free USA/Canada
Email: orderlit@onsemi.com

N. American Technical Support: 800-282-9855 Toll Free
USA/Canada
Europe, Middle East and Africa Technical Support:
Phone: 421 33 790 2910
Japan Customer Focus Center
Phone: 81-3-5773-3850

ON Semiconductor Website: www.onsemi.com
Order Literature: <http://www.onsemi.com/orderlit>

For additional information, please contact your local Sales Representative