



Chipsmall Limited consists of a professional team with an average of over 10 year of expertise in the distribution of electronic components. Based in Hongkong, we have already established firm and mutual-benefit business relationships with customers from,Europe,America and south Asia,supplying obsolete and hard-to-find components to meet their specific needs.

With the principle of “Quality Parts,Customers Priority,Honest Operation,and Considerate Service”,our business mainly focus on the distribution of electronic components. Line cards we deal with include Microchip,ALPS,ROHM,Xilinx,Pulse,ON,Everlight and Freescale. Main products comprise IC,Modules,Potentiometer,IC Socket,Relay,Connector.Our parts cover such applications as commercial,industrial, and automotives areas.

We are looking forward to setting up business relationship with you and hope to provide you with the best service and solution. Let us make a better world for our industry!



Contact us

Tel: +86-755-8981 8866 Fax: +86-755-8427 6832

Email & Skype: info@chipsmall.com Web: www.chipsmall.com

Address: A1208, Overseas Decoration Building, #122 Zhenhua RD., Futian, Shenzhen, China



MC74LVX8051

Analog Multiplexer/ Demultiplexer High-Performance Silicon-Gate CMOS

The MC74LVX8051 utilizes silicon-gate CMOS technology to achieve fast propagation delays, low ON resistances, and low OFF leakage currents. This analog multiplexer/demultiplexer controls analog voltages that may vary across the complete power supply range (from V_{CC} to GND).

The LVX8051 is similar in pinout to the high-speed HC4051A and the metal-gate MC14051B. The Channel-Select inputs determine which one of the Analog Inputs/Outputs is to be connected, by means of an analog switch, to the Common Output/Input. When the Enable pin is HIGH, all analog switches are turned off.

The Channel-Select and Enable inputs are compatible with standard CMOS outputs; with pull-up resistors they are compatible with LSTTL outputs.

This device has been designed so that the ON resistance (R_{on}) is more linear over input voltage than R_{on} of metal-gate CMOS analog switches.

Features

- Fast Switching and Propagation Speeds
- Low Crosstalk Between Switches
- Diode Protection on All Inputs/Outputs
- Analog Power Supply Range ($V_{CC} - GND$) = 2.5 to 6.0 V
- Digital (Control) Power Supply Range ($V_{CC} - GND$) = 2.5 to 6.0 V
- Improved Linearity and Lower ON Resistance Than Metal-Gate Counterparts
- Low Noise
- In Compliance With the Requirements of JEDEC Standard No. 7A
- Chip Complexity: LVX8051 – 184 FETs or 46 Equivalent Gates
- These Devices are Pb-Free and are RoHS Compliant



ON Semiconductor®

<http://onsemi.com>



**SOIC-16
D SUFFIX
CASE 751B**



**TSSOP-16
DT SUFFIX
CASE 948F**

PIN ASSIGNMENT

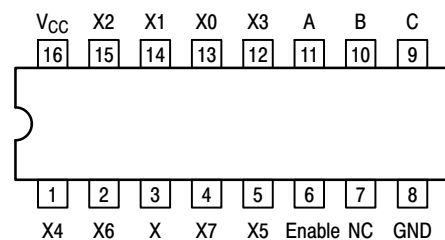

MARKING DIAGRAMS

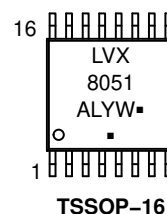
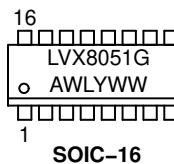

LVX8051 = Specific Device Code
 A = Assembly Location
 WL, L = Wafer Lot
 Y = Year
 WW, W = Work Week
 G or ■ = Pb-Free Package

(Note: Microdot may be in either location)

ORDERING INFORMATION

See detailed ordering and shipping information in the package dimensions section on page 10 of this data sheet.

MC74LVX8051

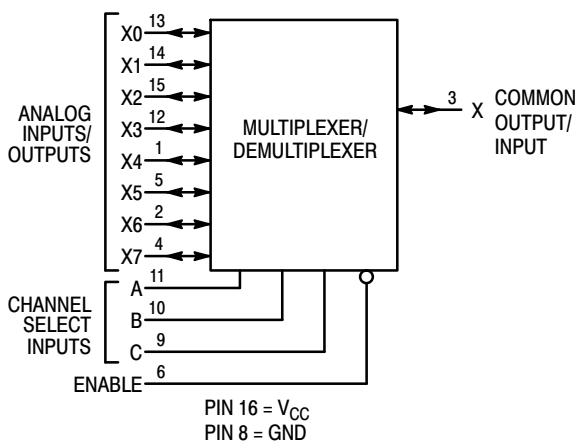

FUNCTION TABLE – MC74LVX8051

| Control Inputs | | | | ON Channels |
|----------------|--------|---|---|-------------|
| Enable | Select | | | |
| | C | B | A | |
| L | L | L | L | X0 |
| L | L | L | H | X1 |
| L | L | H | L | X2 |
| L | L | H | H | X3 |
| L | H | L | L | X4 |
| L | H | L | H | X5 |
| L | H | H | L | X6 |
| L | H | H | H | X7 |
| H | X | X | X | NONE |

X = Don't Care

**LOGIC DIAGRAM
MC74LVX8051**

Single-Pole, 8-Position Plus Common Off

MAXIMUM RATINGS

| Symbol | Parameter | Value | Unit |
|-----------|---|------------------------|------|
| V_{CC} | Positive DC Supply Voltage (Referenced to GND) | -0.5 to +7.0 | V |
| V_{IS} | Analog Input Voltage | -0.5 to $V_{CC} + 0.5$ | V |
| V_{in} | Digital Input Voltage (Referenced to GND) | -0.5 to $V_{CC} + 0.5$ | V |
| I | DC Current, Into or Out of Any Pin | ± 20 | mA |
| P_D | Power Dissipation in Still Air, SOIC Package† TSSOP Package† | 500 450 | mW |
| T_{stg} | Storage Temperature Range | -65 to +150 | °C |
| T_L | Lead Temperature, 1 mm from Case for 10 Seconds | 260 | °C |

This device contains protection circuitry to guard against damage due to high static voltages or electric fields. However, precautions must be taken to avoid applications of any voltage higher than maximum rated voltages to this high-impedance circuit. For proper operation, V_{in} and V_{out} should be constrained to the range $GND \leq (V_{in} \text{ or } V_{out}) \leq V_{CC}$. Unused inputs must always be tied to an appropriate logic voltage level (e.g., either GND or V_{CC}). Unused outputs must be left open.

Stresses exceeding those listed in the Maximum Ratings table may damage the device. If any of these limits are exceeded, device functionality should not be assumed, damage may occur and reliability may be affected.

†Derating: SOIC Package: -7 mW/°C from 65° to 125°C
TSSOP Package: -6.1 mW/°C from 65° to 125°C

RECOMMENDED OPERATING CONDITIONS

| Symbol | Parameter | Min | Max | Unit |
|------------|--|--|----------|------|
| V_{CC} | Positive DC Supply Voltage (Referenced to GND) | 2.5 | 6.0 | V |
| V_{IS} | Analog Input Voltage | 0.0 | V_{CC} | V |
| V_{in} | Digital Input Voltage (Referenced to GND) | GND | V_{CC} | V |
| V_{IO}^* | Static or Dynamic Voltage Across Switch | | 1.2 | V |
| T_A | Operating Temperature Range, All Package Types | -55 | +85 | °C |
| t_r, t_f | Input Rise/Fall Time (Channel Select or Enable Inputs) | $V_{CC} = 3.3 \text{ V} \pm 0.3 \text{ V}$ $V_{CC} = 5.0 \text{ V} \pm 0.5 \text{ V}$ | 0 100 | ns/V |

Functional operation above the stresses listed in the Recommended Operating Ranges is not implied. Extended exposure to stresses beyond the Recommended Operating Ranges limits may affect device reliability.

*For voltage drops across switch greater than 1.2 V (switch on), excessive V_{CC} current may be drawn; i.e., the current out of the switch may contain both V_{CC} and switch input components. The reliability of the device will be unaffected unless the Maximum Ratings are exceeded.

MC74LVX8051

DC CHARACTERISTICS — Digital Section (Voltages Referenced to GND)

| Symbol | Parameter | Condition | V _{CC} V | Guaranteed Limit | | | Unit |
|-----------------|---|--|----------------------|------------------|-------|--------|------|
| | | | | -55 to 25°C | ≤85°C | ≤125°C | |
| V _{IH} | Minimum High-Level Input Voltage, Channel-Select or Enable Inputs | R _{on} = Per Spec | 2.5 | 1.50 | 1.50 | 1.50 | V |
| | | | 3.0 | 2.10 | 2.10 | 2.10 | |
| | | | 4.5 | 3.15 | 3.15 | 3.15 | |
| | | | 5.5 | 3.85 | 3.85 | 3.85 | |
| V _{IL} | Maximum Low-Level Input Voltage, Channel-Select or Enable Inputs | R _{on} = Per Spec | 2.5 | 0.5 | 0.5 | 0.5 | V |
| | | | 3.0 | 0.9 | 0.9 | 0.9 | |
| | | | 4.5 | 1.35 | 1.35 | 1.35 | |
| | | | 5.5 | 1.65 | 1.65 | 1.65 | |
| I _{in} | Maximum Input Leakage Current, Channel-Select or Enable Inputs | V _{in} = V _{CC} or GND | 5.5 | ±0.1 | ±1.0 | ±1.0 | μA |
| I _{CC} | Maximum Quiescent Supply Current (per Package) | Channel Select, Enable and V _{IS} = V _{CC} or GND; V _{IO} = 0 V | 5.5 | 4.0 | 40 | 160 | μA |

DC ELECTRICAL CHARACTERISTICS (Analog Section)

| Symbol | Parameter | Test Conditions | V _{CC} V | Guaranteed Limit | | | Unit |
|------------------|--|--|----------------------|------------------|-------|--------|------|
| | | | | -55 to 25°C | ≤85°C | ≤125°C | |
| R _{on} | Maximum "ON" Resistance | V _{in} = V _{IL} or V _{IH} V _{IS} = V _{CC} to GND I _S ≤ 10.0 mA (Figures 1, 2) | 3.0 | 40 | 45 | 50 | Ω |
| | | | 4.5 | 30 | 32 | 37 | |
| | | | 5.5 | 25 | 28 | 30 | |
| | | V _{in} = V _{IL} or V _{IH} V _{IS} = V _{CC} or GND (Endpoints) I _S ≤ 10.0 mA (Figures 1, 2) | 3.0 | 30 | 35 | 40 | |
| | | | 4.5 | 25 | 28 | 35 | |
| | | | 5.5 | 20 | 25 | 30 | |
| ΔR _{on} | Maximum Difference in "ON" Resistance Between Any Two Channels in the Same Package | V _{in} = V _{IL} or V _{IH} V _{IS} = 1/2 (V _{CC} - GND) I _S ≤ 10.0 mA | 3.0 | 15 | 20 | 25 | Ω |
| | | | 4.5 | 8.0 | 12 | 15 | |
| | | | 5.5 | 8.0 | 12 | 15 | |
| I _{off} | Maximum Off-Channel Leakage Current, Any One Channel | V _{in} = V _{IL} or V _{IH} ; V _{IO} = V _{CC} or GND; Switch Off (Figure 3) | 5.5 | 0.1 | 0.5 | 1.0 | μA |
| | Maximum Off-Channel Leakage Current, Common Channel | V _{in} = V _{IL} or V _{IH} ; V _{IO} = V _{CC} or GND; Switch Off (Figure 4) | 5.5 | 0.2 | 2.0 | 4.0 | |
| I _{on} | Maximum On-Channel Leakage Current, Channel-to-Channel | V _{in} = V _{IL} or V _{IH} ; Switch-to-Switch = V _{CC} or GND; (Figure 5) | 5.5 | 0.2 | 2.0 | 4.0 | μA |

MC74LVX8051

AC CHARACTERISTICS (C_L = 50 pF, Input t_r = t_f = 3 ns)

| Symbol | Parameter | V _{CC} V | Guaranteed Limit | | | Unit |
|--|--|---|------------------|-------|--------|------|
| | | | -55 to 25°C | ≤85°C | ≤125°C | |
| t _{PLH} , t _{PHL} | Maximum Propagation Delay, Channel–Select to Analog Output (Figure 9) | 2.5 | 30 | 35 | 40 | ns |
| | | 3.0 | 20 | 25 | 30 | |
| | | 4.5 | 15 | 18 | 22 | |
| | | 5.5 | 15 | 18 | 20 | |
| t _{PLH} , t _{PHL} | Maximum Propagation Delay, Analog Input to Analog Output (Figure 10) | 2.5 | 4.0 | 6.0 | 8.0 | ns |
| | | 3.0 | 3.0 | 5.0 | 6.0 | |
| | | 4.5 | 1.0 | 2.0 | 2.0 | |
| | | 5.5 | 1.0 | 2.0 | 2.0 | |
| t _{PLZ} , t _{PHZ} | Maximum Propagation Delay, Enable to Analog Output (Figure 11) | 2.5 | 30 | 35 | 40 | ns |
| | | 3.0 | 20 | 25 | 30 | |
| | | 4.5 | 15 | 18 | 22 | |
| | | 5.5 | 15 | 18 | 20 | |
| t _{PZL} , t _{PZH} | Maximum Propagation Delay, Enable to Analog Output (Figure 11) | 2.5 | 20 | 25 | 30 | ns |
| | | 3.0 | 12 | 14 | 15 | |
| | | 4.5 | 8.0 | 10 | 12 | |
| | | 5.5 | 8.0 | 10 | 12 | |
| C _{in} | Maximum Input Capacitance, Channel–Select or Enable Inputs | | 10 | 10 | 10 | pF |
| C _{I/O} | Maximum Capacitance (All Switches Off) | Analog I/O | 35 | 35 | 35 | pF |
| | | Common O/I | 130 | 130 | 130 | |
| | | Feedthrough | 1.0 | 1.0 | 1.0 | |
| C _{PD} | Power Dissipation Capacitance (Figure 13)* | Typical @ 25°C, V _{CC} = 5.0 V | | | pF | |
| | | 45 | | | | |

* Used to determine the no-load dynamic power consumption: $P_D = C_{PD} V_{CC}^2 f + I_{CC} V_{CC}$.

ADDITIONAL APPLICATION CHARACTERISTICS (GND = 0 V)

| Symbol | Parameter | Condition | V _{CC} V | Limit* | Unit |
|--------|--|---|----------------------|----------------------|------------------|
| | | | | 25°C | |
| BW | Maximum On–Channel Bandwidth or Minimum Frequency Response (Figure 6) | f _{in} = 1MHz Sine Wave; Adjust f _{in} Voltage to Obtain 0dBm at V _{OS} ; Increase f _{in} Frequency Until dB Meter Reads –3 dB; R _L = 50 Ω, C _L = 10 pF | 3.0 4.5 5.5 | 80 80 80 | MHz |
| – | Off–Channel Feedthrough Isolation (Figure 7) | f _{in} = Sine Wave; Adjust f _{in} Voltage to Obtain 0dBm at V _{IS} f _{in} = 10 kHz, R _L = 600 Ω, C _L = 50 pF | 3.0 4.5 5.5 | –50 –50 –50 | dB |
| | | f _{in} = 1.0 MHz, R _L = 50 Ω, C _L = 10 pF | 3.0 4.5 5.5 | –37 –37 –37 | |
| – | Feedthrough Noise. Channel–Select Input to Common I/O (Figure 8) | V _{in} ≤ 1MHz Square Wave (t _r = t _f = 6ns); Adjust R _L at Setup so that I _S = 0 A; Enable = GND R _L = 600 Ω, C _L = 50 pF | 3.0 4.5 5.5 | 25 105 135 | mV _{PP} |
| | | R _L = 10 kΩ, C _L = 10 pF | 3.0 4.5 5.5 | 35 145 190 | |
| THD | Total Harmonic Distortion (Figure 14) | f _{in} = 1 kHz, R _L = 10 kΩ, C _L = 50 pF THD = THD _{measured} – THD _{source} V _{IS} = 2.0 V _{PP} sine wave V _{IS} = 4.0 V _{PP} sine wave V _{IS} = 5.0 V _{PP} sine wave | 3.0 4.5 5.5 | 0.10 0.08 0.05 | % |

*Limits not tested. Determined by design and verified by qualification.

MC74LVX8051

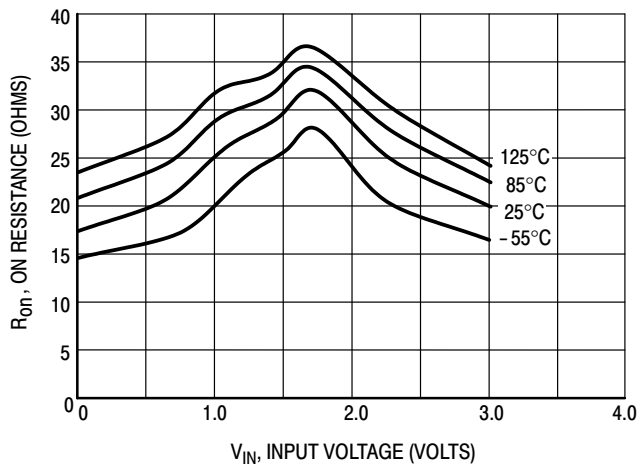

Figure 1a. Typical On Resistance, $V_{CC} = 3.0$ V

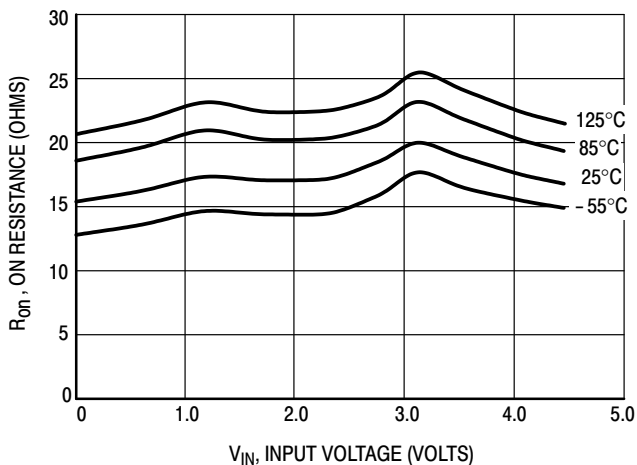

Figure 1b. Typical On Resistance, $V_{CC} = 4.5$ V

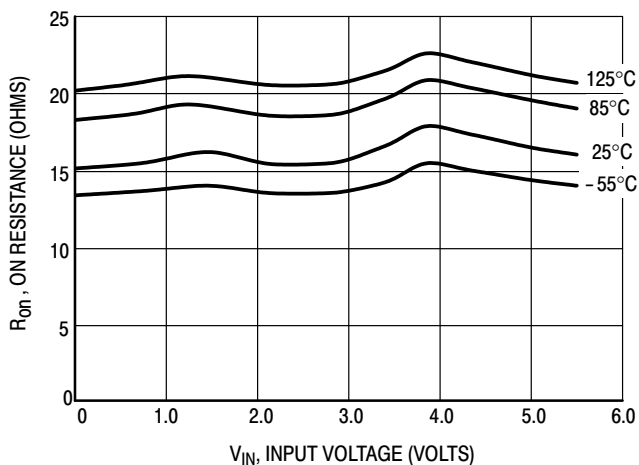

Figure 1c. Typical On Resistance, $V_{CC} = 5.5$ V

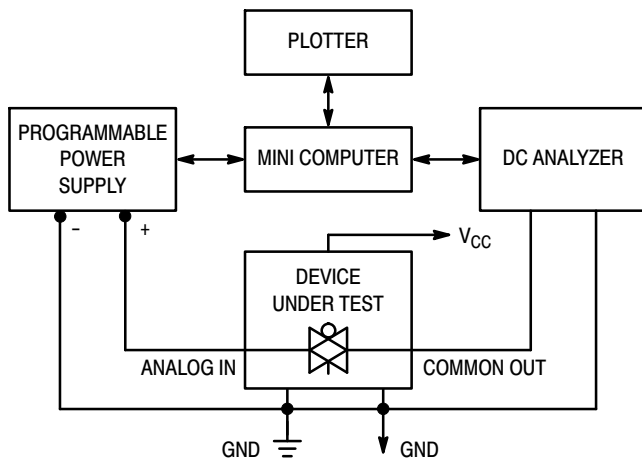

Figure 2. On Resistance Test Set-Up

MC74LVX8051

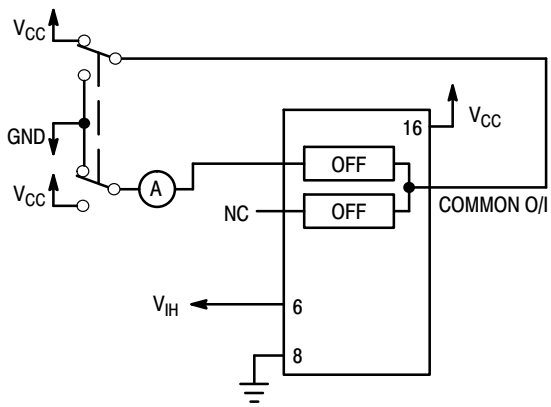

Figure 3. Maximum Off Channel Leakage Current, Any One Channel, Test Set-Up

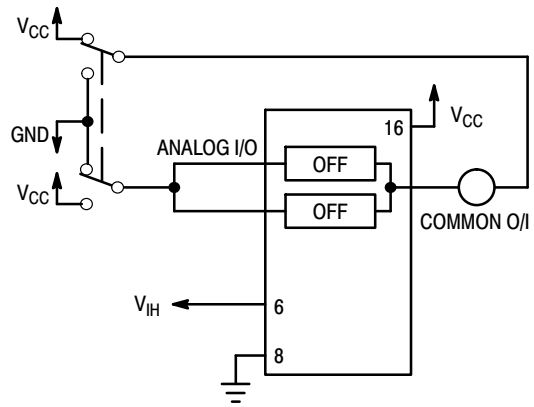

Figure 4. Maximum Off Channel Leakage Current, Common Channel, Test Set-Up

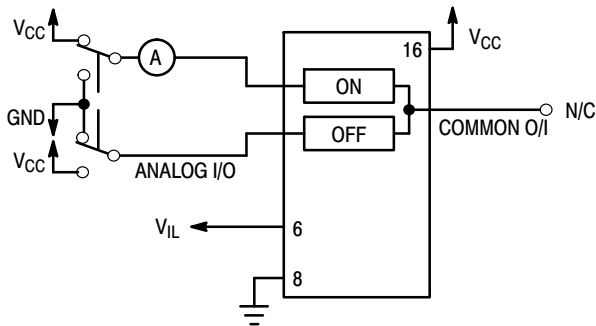
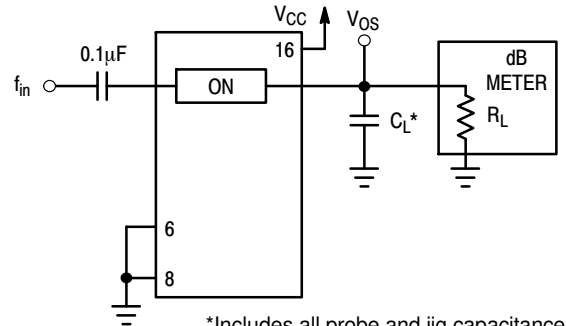
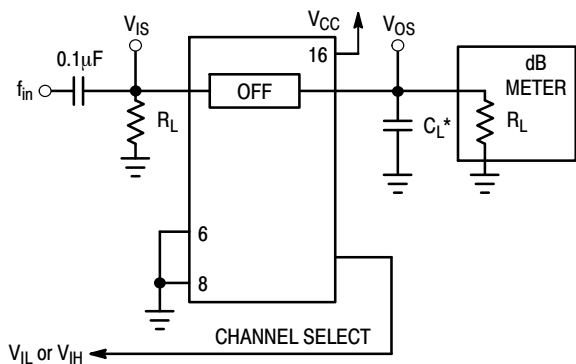

Figure 5. Maximum On Channel Leakage Current, Channel to Channel, Test Set-Up



*Includes all probe and jig capacitance

Figure 6. Maximum On Channel Bandwidth, Test Set-Up



*Includes all probe and jig capacitance

Figure 7. Off Channel Feedthrough Isolation, Test Set-Up

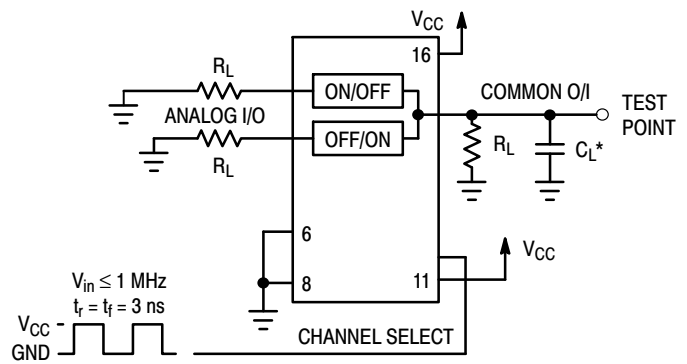

*Includes all probe and jig capacitance

Figure 8. Feedthrough Noise, Channel Select to Common Out, Test Set-Up

MC74LVX8051

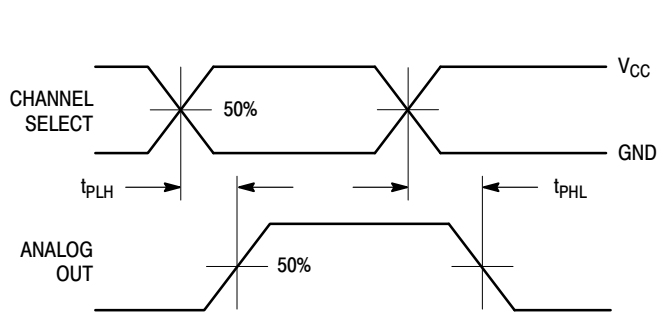
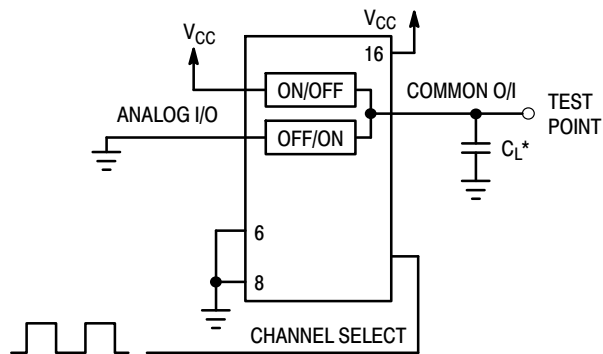

Figure 9a. Propagation Delays, Channel Select to Analog Out



*Includes all probe and jig capacitance

Figure 9b. Propagation Delay, Test Set-Up Channel Select to Analog Out

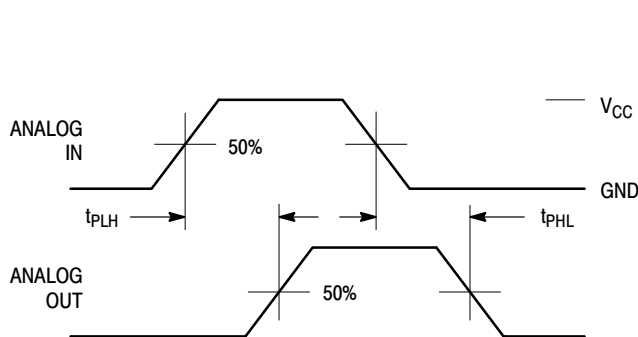
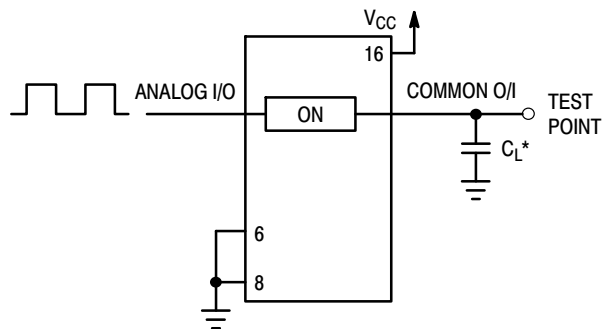

Figure 10a. Propagation Delays, Analog In to Analog Out



*Includes all probe and jig capacitance

Figure 10b. Propagation Delay, Test Set-Up Analog In to Analog Out

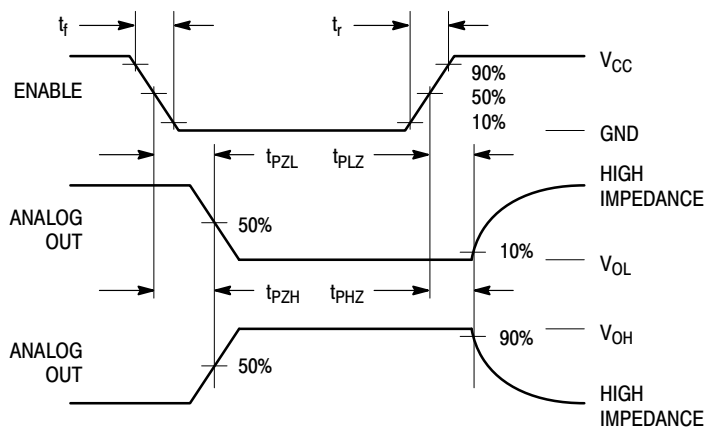

Figure 11a. Propagation Delays, Enable to Analog Out

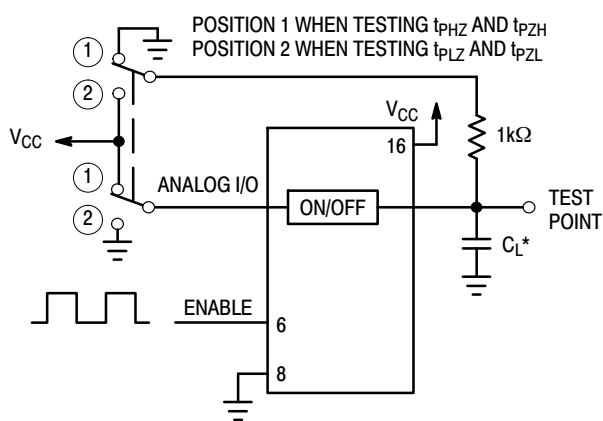
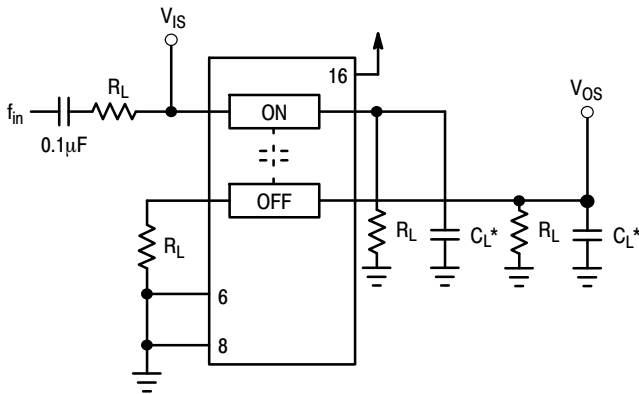

Figure 11b. Propagation Delay, Test Set-Up Enable to Analog Out



*Includes all probe and jig capacitance

Figure 12. Crosstalk Between Any Two Switches, Test Set-Up

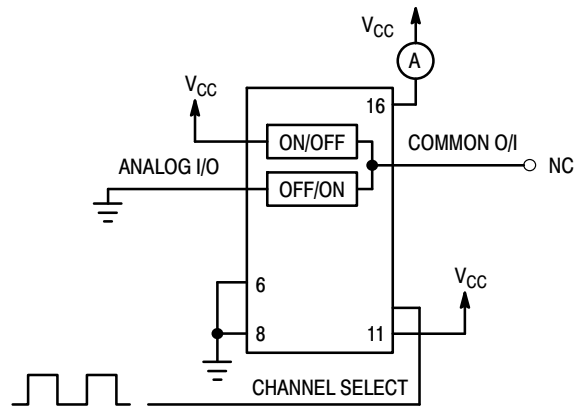
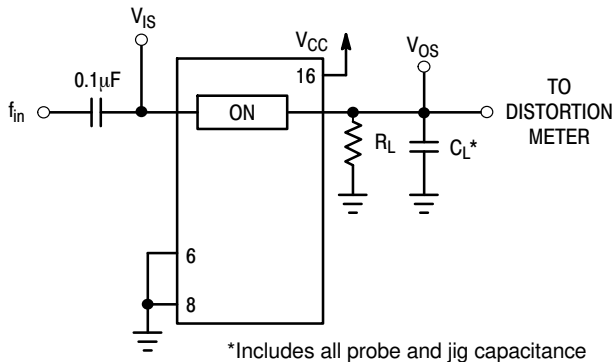

Figure 13. Power Dissipation Capacitance, Test Set-Up



*Includes all probe and jig capacitance

Figure 14a. Total Harmonic Distortion, Test Set-Up

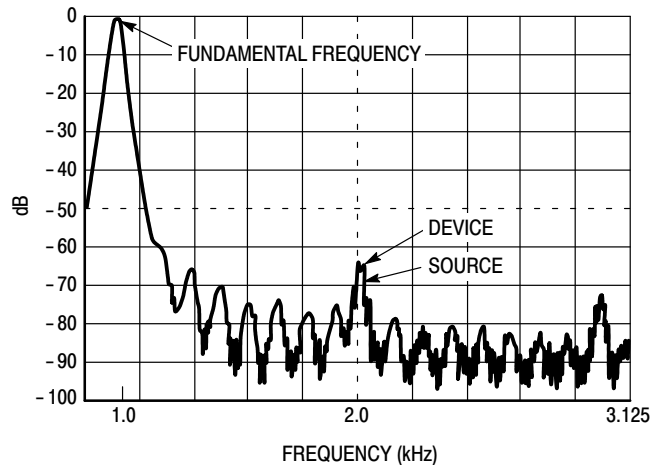

Figure 14b. Plot, Harmonic Distortion

APPLICATIONS INFORMATION

The Channel Select and Enable control pins should be at V_{CC} or GND logic levels. V_{CC} being recognized as a logic high and GND being recognized as a logic low. In this example:

$$\begin{aligned} V_{CC} &= +5V = \text{logic high} \\ GND &= 0V = \text{logic low} \end{aligned}$$

The maximum analog voltage swing is determined by the supply voltage V_{CC} . The positive peak analog voltage should not exceed V_{CC} . Similarly, the negative peak analog voltage should not go below GND. In this example, the difference between V_{CC} and GND is five volts. Therefore, using the configuration of Figure 15, a maximum analog signal of five volts peak-to-peak can be controlled. Unused analog inputs/outputs may be left floating (i.e., not

connected). However, tying unused analog inputs and outputs to V_{CC} or GND through a low value resistor helps minimize crosstalk and feedthrough noise that may be picked up by an unused switch.

Although used here, balanced supplies are not a requirement. The only constraints on the power supplies are that:

$$V_{CC} - GND = 2 \text{ to } 6 \text{ volts}$$

When voltage transients above V_{CC} and/or below GND are anticipated on the analog channels, external Germanium or Schottky diodes (D_x) are recommended as shown in Figure 16. These diodes should be able to absorb the maximum anticipated current surges during clipping.

MC74LVX8051

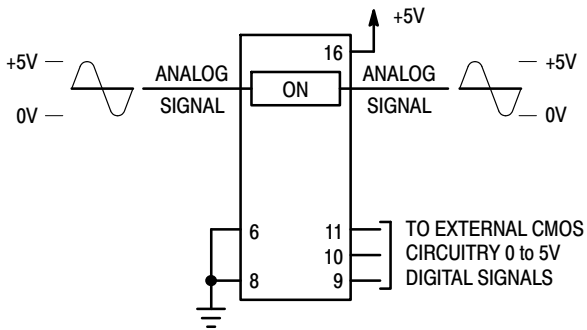

Figure 15. Application Example

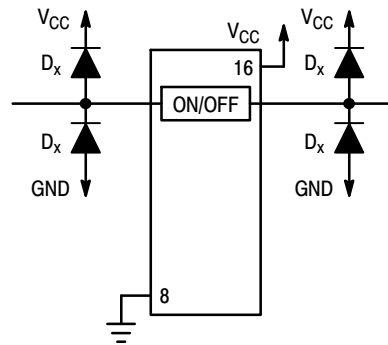
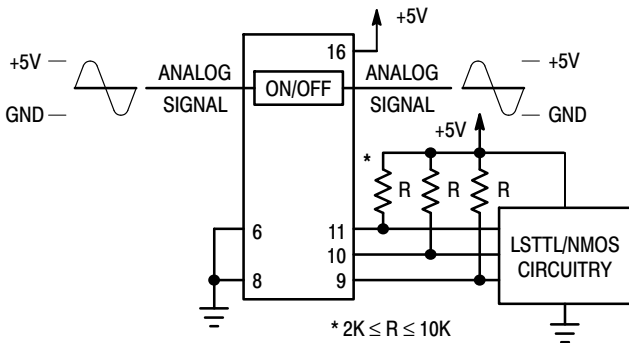
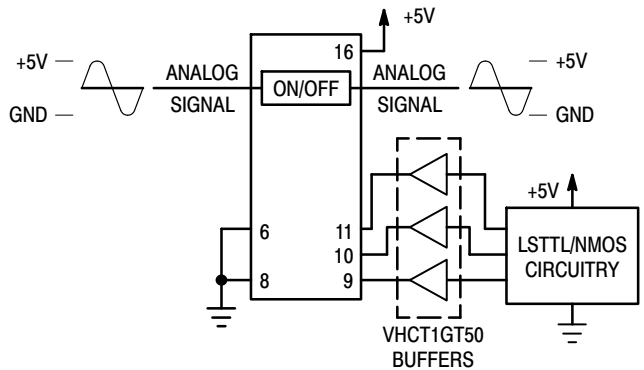

Figure 16. External Germanium or Schottky Clipping Diodes



a. Using Pull-Up Resistors



b. Using HCT Interface

Figure 17. Interfacing LSTTL/NMOS to CMOS Inputs

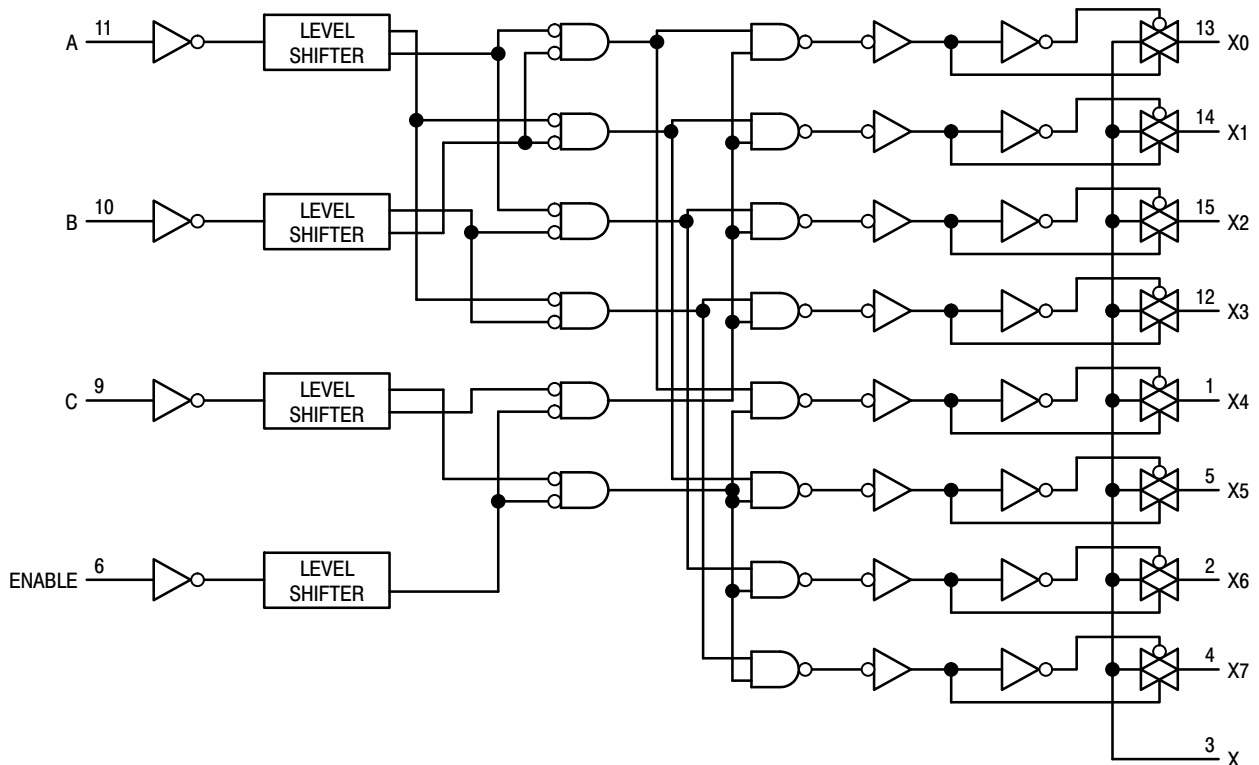

Figure 18. Function Diagram, LVX8051

MC74LVX8051

ORDERING INFORMATION

| Device | Package | Shipping† |
|------------------|-----------------------|------------------|
| MC74LVX8051DR2G | SOIC-16 (Pb-Free) | 2500 Tape & Reel |
| MC74LVX8051DTG | TSSOP-16 (Pb-Free) | 96 Units / Rail |
| MC74LVX8051DTR2G | TSSOP-16 (Pb-Free) | 2500 Tape & Reel |

†For information on tape and reel specifications, including part orientation and tape sizes, please refer to our Tape and Reel Packaging Specifications Brochure, BRD8011/D.

MC74LVX8051

PACKAGE DIMENSIONS

TSSOP-16
CASE 948F
ISSUE B

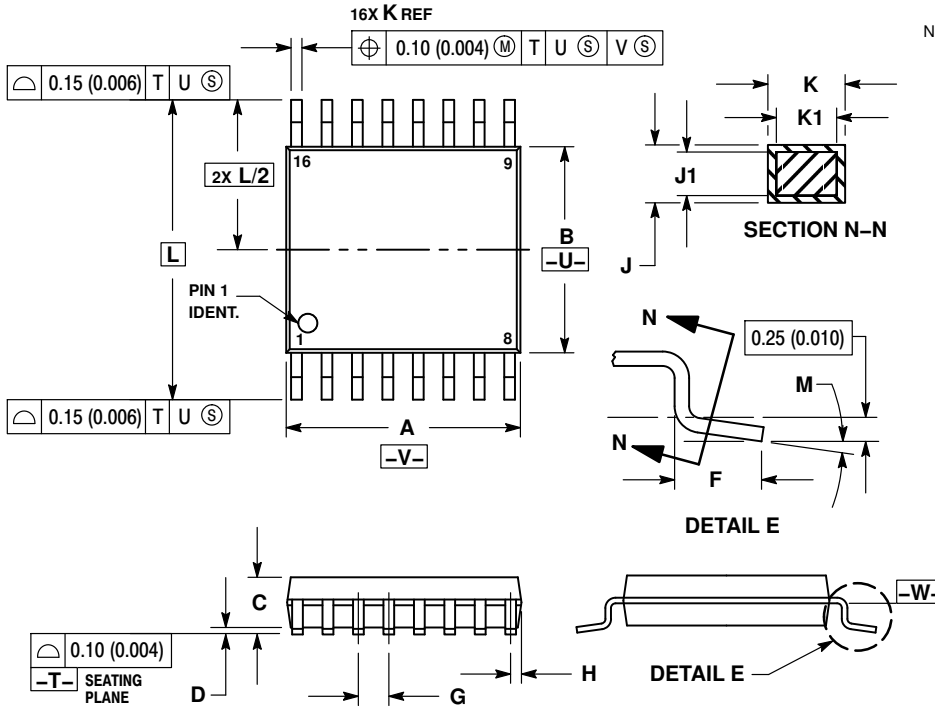

NOTES:

1. DIMENSIONING AND TOLERANCING PER ANSI Y14.5M, 1982.
2. CONTROLLING DIMENSION: MILLIMETER.
3. DIMENSION A DOES NOT INCLUDE MOLD FLASH. PROTRUSIONS OR GATE BURRS. MOLD FLASH OR GATE BURRS SHALL NOT EXCEED 0.15 (0.006) PER SIDE.
4. DIMENSION B DOES NOT INCLUDE INTERLEAD FLASH OR PROTRUSION. INTERLEAD FLASH OR PROTRUSION SHALL NOT EXCEED 0.25 (0.010) PER SIDE.
5. DIMENSION K DOES NOT INCLUDE DAMBAR PROTRUSION. ALLOWABLE DAMBAR PROTRUSION SHALL BE 0.08 (0.003) TOTAL IN EXCESS OF THE K DIMENSION AT MAXIMUM MATERIAL CONDITION.
6. TERMINAL NUMBERS ARE SHOWN FOR REFERENCE ONLY.
7. DIMENSION A AND B ARE TO BE DETERMINED AT DATUM PLANE -W-.

| DIM | MILLIMETERS | | INCHES | |
|-----|-------------|------|-----------|-------|
| | MIN | MAX | MIN | MAX |
| A | 4.90 | 5.10 | 0.193 | 0.200 |
| B | 4.30 | 4.50 | 0.169 | 0.177 |
| C | --- | 1.20 | --- | 0.047 |
| D | 0.05 | 0.15 | 0.002 | 0.006 |
| F | 0.50 | 0.75 | 0.020 | 0.030 |
| G | 0.65 BSC | | 0.026 BSC | |
| H | 0.18 | 0.28 | 0.007 | 0.011 |
| J | 0.09 | 0.20 | 0.004 | 0.008 |
| J1 | 0.09 | 0.16 | 0.004 | 0.006 |
| K | 0.19 | 0.30 | 0.007 | 0.012 |
| K1 | 0.19 | 0.25 | 0.007 | 0.010 |
| L | 6.40 BSC | | 0.252 BSC | |
| M | 0° | 8° | 0° | 8° |

SOLDERING FOOTPRINT*

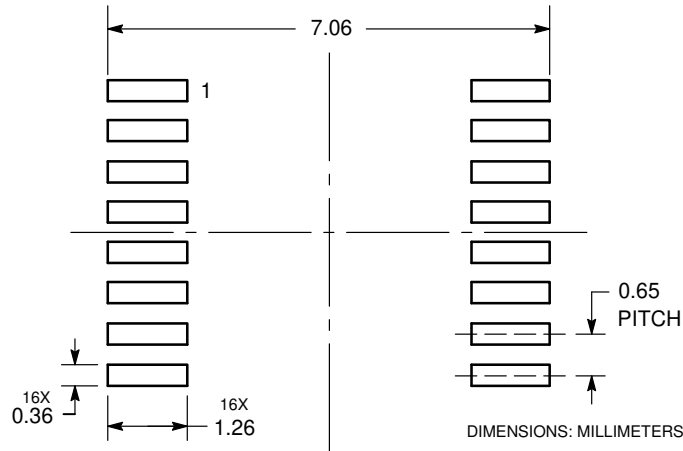

*For additional information on our Pb-Free strategy and soldering details, please download the ON Semiconductor Soldering and Mounting Techniques Reference Manual, SOLDERRM/D.

MC74LVX8051

PACKAGE DIMENSIONS

SOIC-16
CASE 751B-05
ISSUE K

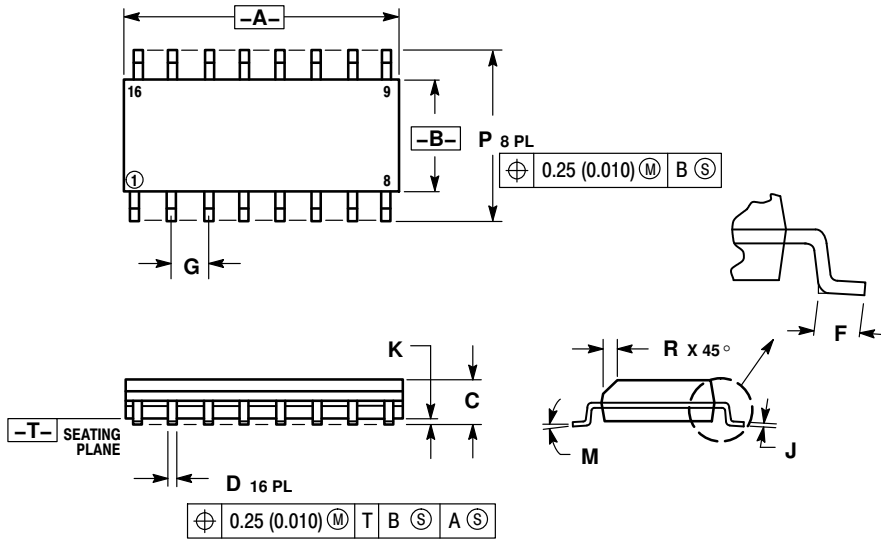

NOTES:

1. DIMENSIONING AND TOLERANCING PER ANSI Y14.5M, 1982.
2. CONTROLLING DIMENSION: MILLIMETER.
3. DIMENSIONS A AND B DO NOT INCLUDE MOLD PROTRUSION.
4. MAXIMUM MOLD PROTRUSION 0.15 (0.006) PER SIDE.
5. DIMENSION D DOES NOT INCLUDE DAMBAR PROTRUSION. ALLOWABLE DAMBAR PROTRUSION SHALL BE 0.127 (0.005) TOTAL IN EXCESS OF THE D DIMENSION AT MAXIMUM MATERIAL CONDITION.

| DIM | MILLIMETERS | | INCHES | |
|-----|-------------|-------|-----------|-------|
| | MIN | MAX | MIN | MAX |
| A | 9.80 | 10.00 | 0.386 | 0.393 |
| B | 3.80 | 4.00 | 0.150 | 0.157 |
| C | 1.35 | 1.75 | 0.054 | 0.068 |
| D | 0.35 | 0.49 | 0.014 | 0.019 |
| F | 0.40 | 1.25 | 0.016 | 0.049 |
| G | 1.27 BSC | | 0.050 BSC | |
| J | 0.19 | 0.25 | 0.008 | 0.009 |
| K | 0.10 | 0.25 | 0.004 | 0.009 |
| M | 0° | 7° | 0° | 7° |
| P | 5.80 | 6.20 | 0.229 | 0.244 |
| R | 0.25 | 0.50 | 0.010 | 0.019 |

SOLDERING FOOTPRINT*

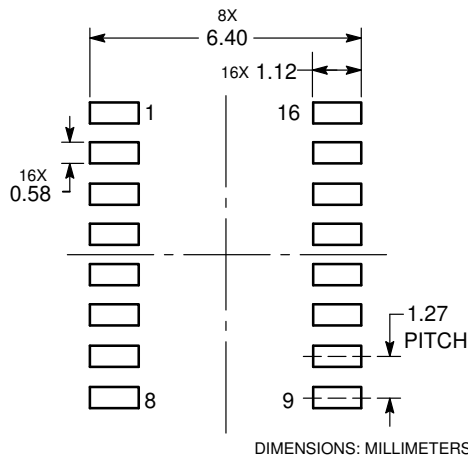

*For additional information on our Pb-Free strategy and soldering details, please download the ON Semiconductor Soldering and Mounting Techniques Reference Manual, SOLDERRM/D.

ON Semiconductor and the  are registered trademarks of Semiconductor Components Industries, LLC (SCILLC) or its subsidiaries in the United States and/or other countries. SCILLC owns the rights to a number of patents, trademarks, copyrights, trade secrets, and other intellectual property. A listing of SCILLC's product/patent coverage may be accessed at www.onsemi.com/site/pdf/Patent-Marking.pdf. SCILLC reserves the right to make changes without further notice to any products herein. SCILLC makes no warranty, representation or guarantee regarding the suitability of its products for any particular purpose, nor does SCILLC assume any liability arising out of the application or use of any product or circuit, and specifically disclaims any and all liability, including without limitation special, consequential or incidental damages. "Typical" parameters which may be provided in SCILLC data sheets and/or specifications can and do vary in different applications and actual performance may vary over time. All operating parameters, including "Typicals" must be validated for each customer application by customer's technical experts. SCILLC does not convey any license under its patent rights nor the rights of others. SCILLC products are not designed, intended, or authorized for use as components in systems intended for surgical implant into the body, or other applications intended to support or sustain life, or for any other application in which the failure of the SCILLC product could create a situation where personal injury or death may occur. Should Buyer purchase or use SCILLC products for any such unintended or unauthorized application, Buyer shall indemnify and hold SCILLC and its officers, employees, subsidiaries, affiliates, and distributors harmless against all claims, costs, damages, and expenses, and reasonable attorney fees arising out of, directly or indirectly, any claim of personal injury or death associated with such unintended or unauthorized use, even if such claim alleges that SCILLC was negligent regarding the design or manufacture of the part. SCILLC is an Equal Opportunity/Affirmative Action Employer. This literature is subject to all applicable copyright laws and is not for resale in any manner.

PUBLICATION ORDERING INFORMATION

LITERATURE FULFILLMENT:

Literature Distribution Center for ON Semiconductor
P.O. Box 5163, Denver, Colorado 80217 USA
Phone: 303-675-2175 or 800-344-3860 Toll Free USA/Canada
Fax: 303-675-2176 or 800-344-3867 Toll Free USA/Canada
Email: orderlit@onsemi.com

N. American Technical Support: 800-282-9855 Toll Free
USA/Canada
Europe, Middle East and Africa Technical Support:
Phone: 421 33 790 2910
Japan Customer Focus Center
Phone: 81-3-5817-1050

ON Semiconductor Website: www.onsemi.com

Order Literature: <http://www.onsemi.com/orderlit>

For additional information, please contact your local Sales Representative