



Chipsmall Limited consists of a professional team with an average of over 10 year of expertise in the distribution of electronic components. Based in Hongkong, we have already established firm and mutual-benefit business relationships with customers from,Europe,America and south Asia,supplying obsolete and hard-to-find components to meet their specific needs.

With the principle of “Quality Parts,Customers Priority,Honest Operation,and Considerate Service”,our business mainly focus on the distribution of electronic components. Line cards we deal with include Microchip,ALPS,ROHM,Xilinx,Pulse,ON,Everlight and Freescale. Main products comprise IC,Modules,Potentiometer,IC Socket,Relay,Connector.Our parts cover such applications as commercial,industrial, and automotives areas.

We are looking forward to setting up business relationship with you and hope to provide you with the best service and solution. Let us make a better world for our industry!



## Contact us

Tel: +86-755-8981 8866 Fax: +86-755-8427 6832

Email & Skype: info@chipsmall.com Web: www.chipsmall.com

Address: A1208, Overseas Decoration Building, #122 Zhenhua RD., Futian, Shenzhen, China



## Low Voltage Low Skew CMOS PLL Clock Driver, 3-State

The MC88LV915T Clock Driver utilizes phase-locked loop technology to lock its low skew outputs' frequency and phase onto an input reference clock. It is designed to provide clock distribution for high performance PC's and workstations.

The PLL allows the high current, low skew outputs to lock onto a single clock input and distribute it with essentially zero delay to multiple components on a board. The PLL also allows the MC88LV915T to multiply a low frequency input clock and distribute it locally at a higher (2X) system frequency. Multiple 88LV915's can lock onto a single reference clock, which is ideal for applications when a central system clock must be distributed synchronously to multiple boards (see Figure 4 on Page 9).

Five "Q" outputs (Q0-Q4) are provided with less than 500 ps skew between their rising edges. The  $\overline{Q5}$  output is inverted (180° phase shift) from the "Q" outputs. The 2X\_Q output runs at twice the "Q" output frequency, while the Q/2 runs at 1/2 the "Q" frequency.

The VCO is designed to run optimally between 20 MHz and the 2X\_Q  $F_{max}$  specification. The wiring diagrams in Figure 2 detail the different feedback configurations which create specific input/output frequency relationships. Possible frequency ratios of the "Q" outputs to the SYNC input are 2:1, 1:1, and 1:2.

The  $FREQ\_SEL$  pin provides one bit programmable divide-by in the feedback path of the PLL. It selects between divide-by-1 and divide-by-2 of the VCO before its signal reaches the internal clock distribution section of the chip (see the block diagram on page 2). In most applications  $FREQ\_SEL$  should be held high (+1). If a low frequency reference clock input is used, holding  $FREQ\_SEL$  low (+2) will allow the VCO to run in its optimal range (>20MHz).

In normal phase-locked operation the  $PLL\_EN$  pin is held high. Pulling the  $PLL\_EN$  pin low disables the VCO and puts the 88LV915T in a static "test mode". In this mode there is no frequency limitation on the input clock, which is necessary for a low frequency board test environment. The second SYNC input can be used as a test clock input to further simplify board-level testing (see detailed description on page 11).

Pulling the  $\overline{OE/RST}$  pin low puts the clock outputs 2X\_Q, Q0-Q4,  $\overline{Q5}$  and Q/2 into a high impedance state (3-state). After the  $\overline{OE/RST}$  pin goes back high Q0-Q4,  $\overline{Q5}$  and Q/2 will be reset in the low state, with 2X\_Q being the inverse of the selected SYNC input. Assuming  $PLL\_EN$  is low, the outputs will remain reset until the 88LV915 sees a SYNC input pulse.

A lock indicator output (LOCK) will go high when the loop is in steady-state phase and frequency lock. The LOCK output will go low if phase-lock is lost or when the  $PLL\_EN$  pin is low. The LOCK output will go high no later than 10ms after the 88LV915 sees a SYNC signal and full 5V  $V_{CC}$ .

### Features

- Five Outputs (Q0-Q4) with Output-Output Skew < 500 ps each being phase and frequency locked to the SYNC input
- The phase variation from part-to-part between the SYNC and FEEDBACK inputs is less than 550 ps (derived from the  $t_{PD}$  specification, which defines the part-to-part skew)
- Input/Output phase-locked frequency ratios of 1:2, 1:1, and 2:1 are available
- Input frequency range from 5MHz – 2X\_Q  $F_{MAX}$  spec.
- Additional outputs available at 2X and +2 the system "Q" frequency. Also a  $\overline{Q}$  (180° phase shift) output available
- All outputs have  $\pm 36$  mA drive (equal high and low) at CMOS levels, and can drive either CMOS or TTL inputs. All inputs are TTL-level compatible.  $\pm 88$ mA  $I_{OL}/I_{OH}$  specifications guarantee 50 $\Omega$  transmission line switching on the incident edge
- Test Mode pin ( $PLL\_EN$ ) provided for low frequency testing. Two selectable CLOCK inputs for test or redundancy purposes. All outputs can go into high impedance (3-state) for board test purposes
- Lock Indicator (LOCK) accuracy indicates a phase-locked state

Yield Surface Modeling and YSM are trademarks of Motorola, Inc.

**MC88LV915T**

**LOW SKEW CMOS  
PLL CLOCK DRIVER**

**Pinout: 28-Lead PLCC (Top View)**

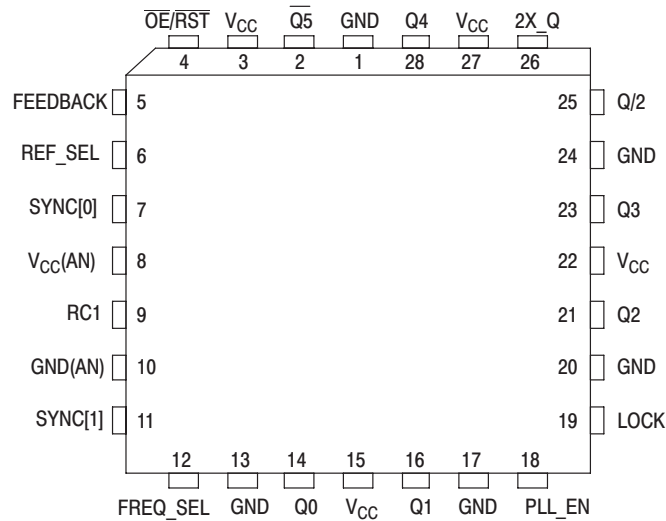

**FN SUFFIX**  
 PLASTIC PLCC  
 CASE 776-02

**PIN SUMMARY**

Pin Name	Num	I/O	Function
SYNC[0]	1	Input	Reference clock input
SYNC[1]	1	Input	Reference clock input
REF_SEL	1	Input	Chooses reference between sync[0] & Sync[1]
FREQ_SEL	1	Input	Doubles VCO Internal Frequency (low)
FEEDBACK	1	Input	Feedback input to phase detector
RC1	1	Input	Input for external RC network
Q(0-4)	5	Output	Clock output (locked to sync)
$\overline{Q5}$	1	Output	Inverse of clock output
2x_Q	1	Output	2 x clock output (Q) frequency (synchronous)
Q/2	1	Output	Clock output(Q) frequency $\div 2$ (synchronous)
LOCK	1	Output	Indicates phase lock has been achieved (high when locked)
$\overline{OE/RST}$	1	Input	Output Enable/Asynchronous reset (active low)
PLL_EN	1	Input	Disables phase-lock for low freq. testing
V <sub>CC</sub> ,GND	11		Power and ground pins (note pins 8, 10 are "analog" supply pins for internal PLL only)

### MC88LV915T BLOCK DIAGRAM

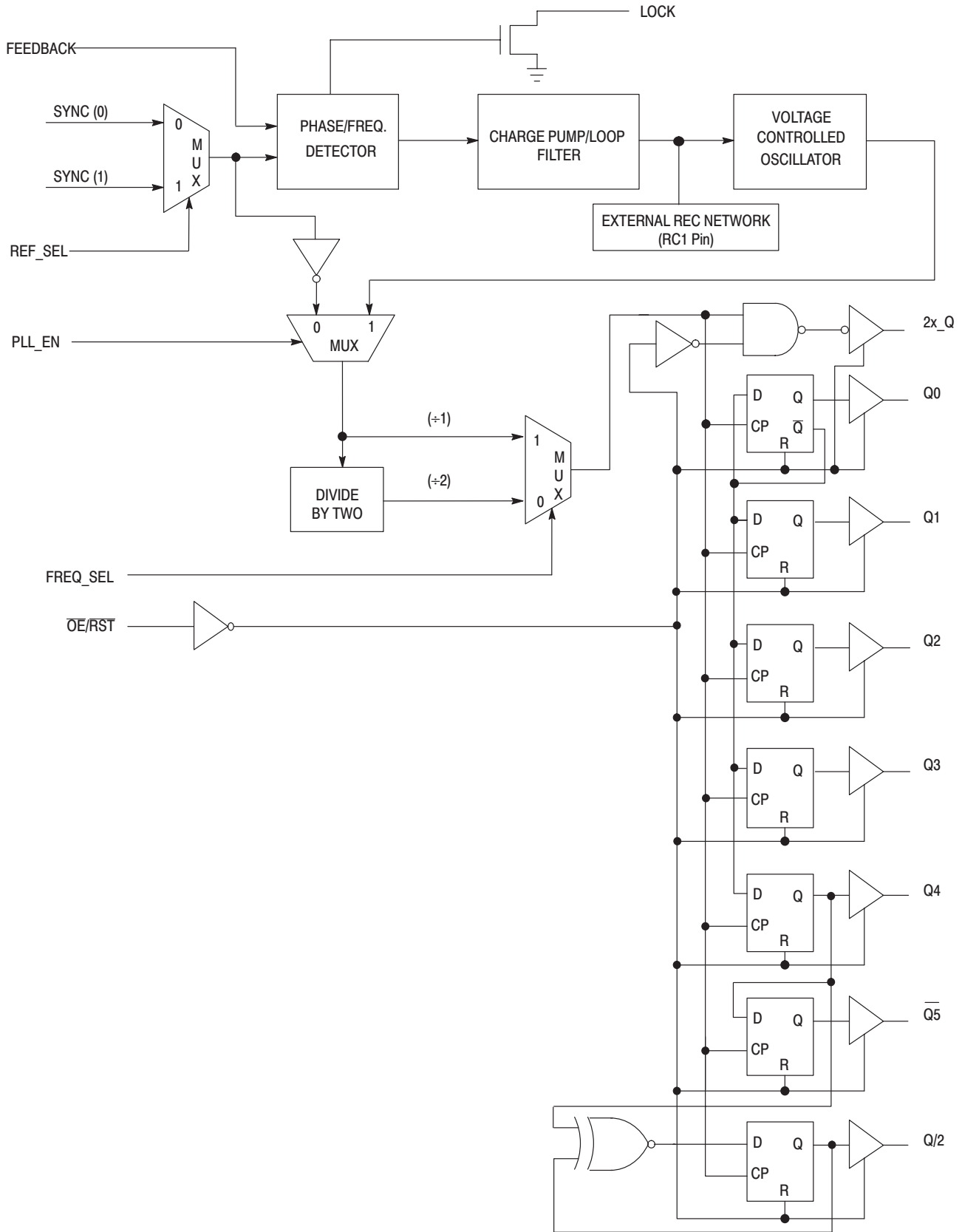

## MAXIMUM RATINGS\*

Symbol	Parameter	Limits	Unit
$V_{CC}, AV_{CC}$	DC Supply Voltage Referenced to GND	-0.5 to 7.0	V
$V_{in}$	DC Input Voltage (Referenced to GND)	-0.5 to $V_{CC} + 0.5$	V
$V_{out}$	DC Output Voltage (Referenced to GND)	-0.5 to $V_{CC} + 0.5$	V
$I_{in}$	DC Input Current, Per Pin	$\pm 20$	mA
$I_{out}$	DC Output Sink/Source Current, Per Pin	$\pm 50$	mA
$I_{CC}$	DC $V_{CC}$ or GND Current Per Output Pin	$\pm 50$	mA
$T_{stg}$	Storage Temperature	-65 to +150	$^{\circ}C$

\* Maximum Ratings are those values beyond which damage to the device may occur. Functional operation should be restricted to the Recommended Operating Conditions.

## RECOMMENDED OPERATING CONDITIONS

Symbol	Parameter	Limits	Unit
$V_{CC}$	Supply Voltage	$3.3 \pm 0.3$	V
$V_{in}$	DC Input Voltage	0 to $V_{CC}$	V
$V_{out}$	DC Output Voltage	0 to $V_{CC}$	V
$T_A$	Ambient Operating Temperature	0 to 70	$^{\circ}C$
ESD	Static Discharge Voltage	> 1000	V

## DC CHARACTERISTICS ( $T_A = 0^{\circ}C$ to $70^{\circ}C$ ; $V_{CC} = 3.3V \pm 0.3V$ )

Symbol	Parameter	$V_{CC}$	Guaranteed Limits	Unit	Condition
$V_{IH}$	Minimum High Level Input Voltage	3.0 3.3	2.0 2.0	V	$V_{OUT} = 0.1V$ or $V_{CC} - 0.1V$
$V_{IL}$	Minimum Low Level Input Voltage	3.0 3.3	0.8 0.8	V	$V_{OUT} = 0.1V$ or $V_{CC} - 0.1V$
$V_{OH}$	Minimum High Level Output Voltage	3.0 3.3	2.4 2.7	V	$V_{IN} = V_{IH}$ or $V_{IL}$ $I_{OH} = -24mA$
$V_{OL}$	Minimum Low Level Output Voltage	3.0 3.3	0.44 0.44	V	$V_{IN} = V_{IH}$ or $V_{IL}$ $I_{OH} = 24mA$
$I_{IN}$	Maximum Input Leakage Current	3.6	$\pm 1.0$	$\mu A$	$V_I = V_{CC}, GND$
$I_{CCT}$	Maximum $I_{CC}/Input$	3.6	2.0	mA	$V_I = V_{CC} - 2.1V$
$I_{OLD}$	Minimum Dynamic <sup>3</sup> Output Current	3.6	+50	mA	$V_{OLD} = 1.25V$
$I_{OHD}$		3.6	-50	mA	$V_{OHD} = 2.35V$
$I_{CC}$	Maximum Quiescent Supply Current	3.6	TBD	$\mu A$	$V_I = V_{CC}, GND$

- $I_{OL}$  is +12mA for the  $RST\_OUT$  output.
- The  $PLL\_EN$  input pin is not guaranteed to meet this specification.
- Maximum test duration 2.0ms, one output loaded at a time.

## SYNC INPUT TIMING REQUIREMENTS

Symbol	Parameter	Minimum	Maximum	Unit
$t_{RISE/FALL}$ SYNC Input	Rise/Fall Time, SYNC Input From 0.8V to 2.0V	—	5.0	ns
$t_{CYCLE}$ SYNC Input	Input Clock Period SYNC Input	$\frac{1}{f_{2X\_Q/4}}$	100	ns
Duty Cycle	Duty Cycle, SYNC Input	50% $\pm$ 25%		

**FREQUENCY SPECIFICATIONS** ( $T_A = 0^\circ\text{C}$  to  $70^\circ\text{C}$ ;  $V_{CC} = 3.3\text{V} \pm 0.3\text{V}$ )

Symbol	Parameter	Guaranteed Minimum	Unit
Fmax (2X_Q)	Maximum Operating Frequency, 2X_Q Output	100	MHz
Fmax ('Q')	Maximum Operating Frequency, Q0–Q3 Outputs	50	MHz

NOTE: Maximum Operating Frequency is guaranteed with the 88LV926 in a phase-locked condition.

**AC CHARACTERISTICS** ( $T_A = 0^\circ\text{C}$  to  $+70^\circ\text{C}$ ,  $V_{CC} = 3.3\text{V} \pm 0.3\text{V}$ , Load =  $50\Omega$  Terminated to  $V_{CC}/2$ )

Symbol	Parameter	Min	Max	Unit	Condition	
$t_{RISE/FALL}$ Outputs	Rise/Fall Time, All Outputs (Between 0.8 to 2.0V)	0.5	2.0	ns	Into a $50\Omega$ Load Terminated to $V_{CC}/2$	
$t_{PULSE\ WIDTH}$ (Q0–Q4, Q5, Q/2)	Output Pulse Width: Q0, Q1, Q2, Q3, Q4, Q5, Q/2 @ $V_{CC}/2$	$0.5t_{CYCLE} - 0.5$ <sup>1</sup>	$0.5t_{CYCLE} + 0.5$ <sup>1</sup>	ns	Into a $50\Omega$ Load Terminated to $V_{CC}/2$	
$t_{PULSE\ WIDTH}$ (2X_Q Output)	Output Pulse Width: 2X_Q @ 1.5V	40MHz 66MHz 80MHz 100MHz	$0.5t_{CYCLE} - 1.5$ $0.5t_{CYCLE} - 1.0$ $0.5t_{CYCLE} - 1.0$ $0.5t_{CYCLE} - 1.0$	$0.5t_{CYCLE} + 0.5$ $0.5t_{CYCLE} + 0.5$ $0.5t_{CYCLE} + 0.5$ $0.5t_{CYCLE} + 0.5$	ns	Into a $50\Omega$ Load Terminated to $V_{CC}/2$
$t_{CYCLE}$ (2X_Q Output)	Cycle-to-Cycle Variation 2x_Q @ $V_{CC}/2$	40MHz 66MHz 80MHz 100MHz	$t_{CYCLE} - 600\text{ps}$ $t_{CYCLE} - 300\text{ps}$ $t_{CYCLE} - 300\text{ps}$ $t_{CYCLE} - 400\text{ps}$	$t_{CYCLE} + 600\text{ps}$ $t_{CYCLE} + 300\text{ps}$ $t_{CYCLE} + 300\text{ps}$ $t_{CYCLE} + 400\text{ps}$		
$t_{PD}^2$ SYNC Feedback		(With $1\text{M}\Omega$ from RC1 to An $V_{CC}$ )		ns		
	SYNC Input to Feedback Delay (Measured at SYNC0 or 1 and FEEDBACK Input Pins)	66MHz 80MHz 100MHz	$-1.65$ $-1.45$ $-1.25$	$-1.05$ $-0.85$ $-0.65$		
$t_{SKEW}^3$ (Rising) See Note 4	Output-to-Output Skew Between Outputs Q0–Q4, Q/2 (Rising Edges Only)	—	500	ps	All Outputs Into a Matched $50\Omega$ Load Terminated to $V_{CC}/2$	
$t_{SKEW}^3$ (Falling)	Output-to-Output Skew Between Outputs Q0–Q4 (Falling Edges Only)	—	750	ps	All Outputs Into a Matched $50\Omega$ Load Terminated to $V_{CC}/2$	
$t_{SKEW}^3$	Output-to-Output Skew 2X_Q, Q/2, Q0–Q4 Rising, Q5 Falling	—	750	ps	All Outputs Into a Matched $50\Omega$ Load Terminated to $V_{CC}/2$	
$t_{LOCK}^4$	Time Required to Acquire Phase-Lock From Time SYNC Input Signal is Received	1.0	10	ms	Also Time to LOCK Indicator High	
$t_{PZL}^5$	Output Enable Time $\overline{OE}/\overline{RST}$ to 2X_Q, Q0–Q4, Q5, and Q/2	3.0	14	ns	Measured With the PLL_EN Pin Low	
$t_{PHZ}, t_{PLZ}^5$	Output Disable Time $\overline{OE}/\overline{RST}$ to 2X_Q, Q0–Q4, Q5, and Q/2	3.0	14	ns	Measured With the PLL_EN Pin Low	

- $t_{CYCLE}$  in this spec is  $1/\text{Frequency}$  at which the particular output is running.
- The  $t_{PD}$  specification's min/max values may shift closer to zero if a larger pullup resistor is used.
- Under equally loaded conditions and at a fixed temperature and voltage.
- With  $V_{CC}$  fully powered-on, and an output properly connected to the FEEDBACK pin.  $t_{LOCK}$  maximum is with  $C1 = 0.1\mu\text{F}$ ,  $t_{LOCK}$  minimum is with  $C1 = 0.01\mu\text{F}$ .
- The  $t_{PZL}$ ,  $t_{PHZ}$ ,  $t_{PLZ}$  minimum and maximum specifications are estimates, the final guaranteed values will be available when 'MC' status is reached.

## Applications Information for All Versions

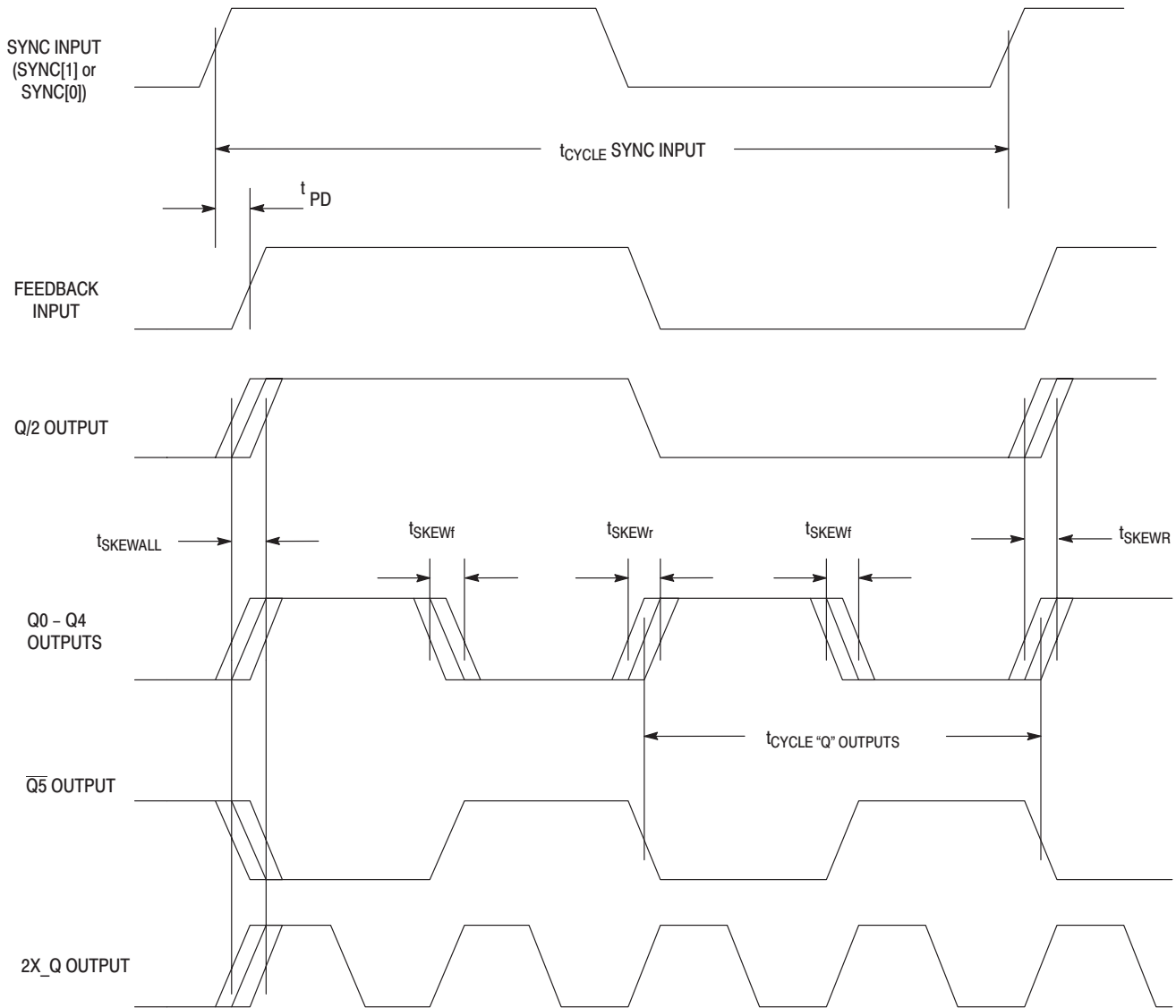
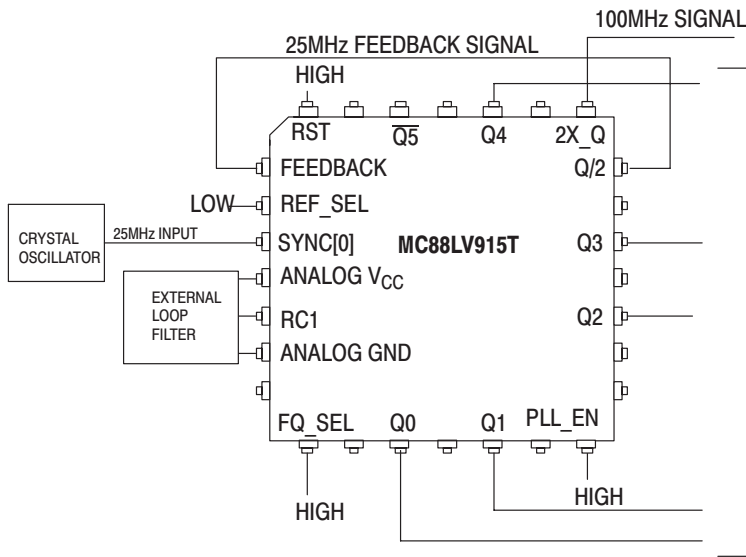

**Figure 1. Output/Input Switching Waveforms and Timing Diagrams**

(These waveforms represent the hook-up configuration of Figure 2a on page 7)

### Timing Notes:

- The MC88LV915T aligns rising edges of the FEEDBACK input and SYNC input, therefore the SYNC input does not require a 50% duty cycle.
- All skew specs are measured between the  $V_{\text{CC}}/2$  crossing point of the appropriate output edges. All skews are specified as 'windows', not as a  $\pm$  deviation around a center point.
- If a "Q" output is connected to the FEEDBACK input (this situation is not shown), the "Q" output frequency would match the SYNC input frequency, the 2X\_Q output would run at twice the SYNC frequency, and the Q/2 output would run at half the SYNC frequency.



### 1:2 Input to "Q" Output Frequency Relationship

In this application, the Q/2 output is connected to the FEEDBACK input. The internal PLL will line up the positive edges of Q/2 and SYNC, thus the Q/2 frequency will equal the SYNC frequency. The "Q" outputs (Q0-Q4, Q<sub>5</sub>) will always run at 2X the Q/2 frequency, and the 2X\_Q output will run at 4X the Q/2 frequency.

50MHz "Q" CLOCK OUTPUTS

#### Allowable Input Frequency Range:

5MHz to (2X\_Q FMAX Spec)/4 (for FREQ\_SEL HIGH)  
 2.5MHz to (2X\_Q FMAX Spec)/8 (for FREQ\_SEL LOW)

Note: If the  $\overline{OE}/\overline{RST}$  input is active, a pull-up or pull-down resistor isn't necessary at the FEEDBACK pin so it won't when the fed back output goes into 3-state.

Figure 2a. Wiring Diagram and Frequency Relationships With Q/2 Output Feed Back

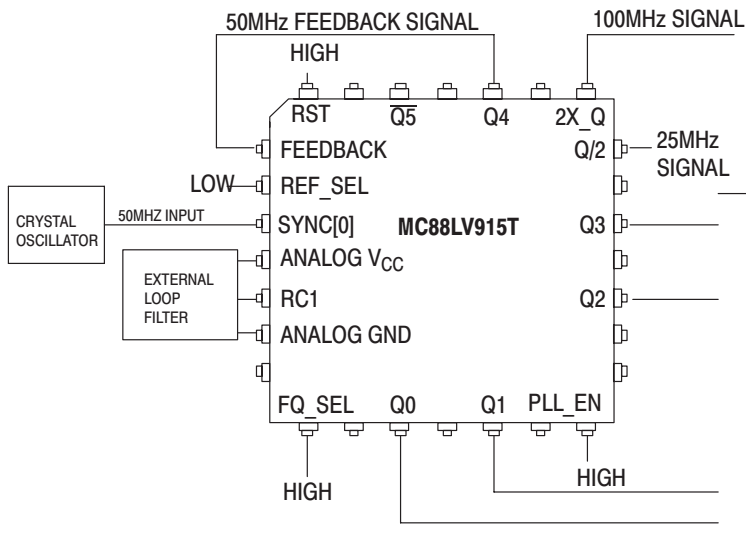

### 1:1 Input to "Q" Output Frequency Relationship

In this application, the Q4 output is connected to the FEEDBACK input. The internal PLL will line up the positive edges of Q4 and SYNC, thus the Q4 frequency (and the rest of the "Q" outputs) will equal the SYNC frequency. The Q/2 output will always run at 1/2 the "Q" frequency, and the 2X\_Q output will run at 2X the "Q" frequency.

50MHz "Q" CLOCK OUTPUTS

#### Allowable Input Frequency Range:

10MHz to (2X\_Q FMAX Spec)/2 (for FREQ\_SEL HIGH)  
 5MHz to (2X\_Q FMAX Spec)/4 (for FREQ\_SEL LOW)

Figure 2b. Wiring Diagram and Frequency Relationships With Q4 Output Feed Back

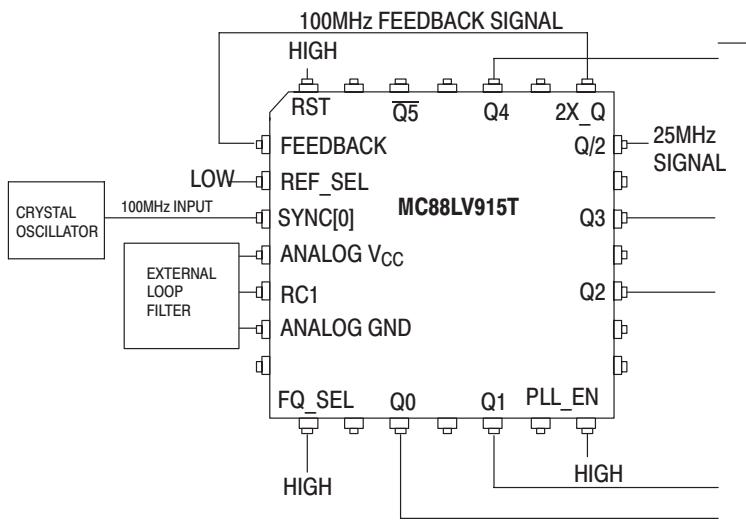

### 2:1 Input to "Q" Output Frequency Relationship

In this application, the 2X\_Q output is connected to the FEEDBACK input. The internal PLL will line up the positive edges of 2X\_Q and SYNC, thus the 2X\_Q frequency will equal the SYNC frequency. The Q/2 output will always run at 1/4 the 2X\_Q frequency, and the "Q" outputs will run at 1/2 the 2X\_Q frequency.

50MHz "Q" CLOCK OUTPUTS

#### Allowable Input Frequency Range:

20MHz to (2X\_Q FMAX Spec) (for FREQ\_SEL HIGH)  
 10MHz to (2X\_Q FMAX Spec)/2 (for FREQ\_SEL LOW)

Figure 2c. Wiring Diagram and Frequency Relationships with 2X\_Q Output Feed Back



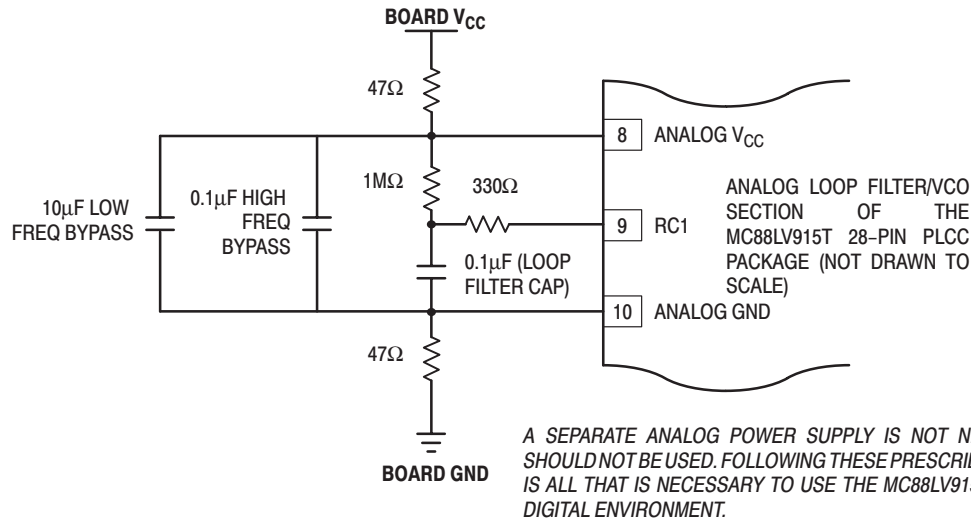

**Figure 3. Recommended Loop Filter and Analog Isolation Scheme for the MC88LV915T**

### Notes Concerning Loop Filter and Board Layout Issues

1. Figure 3 shows a loop filter and analog isolation scheme which will be effective in most applications. The following guidelines should be followed to ensure stable and jitter-free operation:

1a. All loop filter and analog isolation components should be tied as close to the package as possible. Stray current passing through the parasitics of long traces can cause undesirable voltage transients at the RC1 pin.

1b. The 47Ω resistors, the 10µF low frequency bypass capacitor, and the 0.1µF high frequency bypass capacitor form a wide bandwidth filter that will minimize the 88LV915T's sensitivity to voltage transients from the system digital V<sub>CC</sub> supply and ground planes. This filter will typically ensure that a 100mV step deviation on the digital V<sub>CC</sub> supply will cause no more than a 100pS phase deviation on the 88LV915T outputs. A 250mV step deviation on V<sub>CC</sub> using the recommended filter values should cause no more than a 250pS phase deviation; if a 25µF bypass capacitor is used (instead of 10µF) a 250mV V<sub>CC</sub> step should cause no more than a 100pS phase deviation.

If good bypass techniques are used on a board design near components which may cause digital V<sub>CC</sub> and ground noise, the above described V<sub>CC</sub> step deviations should not occur at the 88LV915T's digital V<sub>CC</sub> supply. The purpose

of the bypass filtering scheme shown in Figure 3 is to give the 88LV915T additional protection from the power supply and ground plane transients that can occur in a high frequency, high speed digital system.

1c. There are no special requirements set forth for the loop filter resistors (1MΩ and 330Ω). The loop filter capacitor (0.1µF) can be a ceramic chip capacitor, the same as a standard bypass capacitor.

1d. The 1M reference resistor injects current into the internal charge pump of the PLL, causing a fixed offset between the outputs and the SYNC input. This also prevents excessive jitter caused by inherent PLL dead-band. If the VCO (2X\_Q output) is running above 40MHz, the 1MΩ resistor provides the correct amount of current injection into the charge pump (2–3µA). For the TFN55, 70 or 100, if the VCO is running below 40MHz, a 1.5MΩ reference resistor should be used (instead of 1MΩ).

2. In addition to the bypass capacitors used in the analog filter of Figure 3, there should be a 0.1µF bypass capacitor between each of the other (digital) four V<sub>CC</sub> pins and the board ground plane. This will reduce output switching noise caused by the 88LV915T outputs, in addition to reducing potential for noise in the 'analog' section of the chip. These bypass capacitors should also be tied as close to the 88LV915T package as possible.

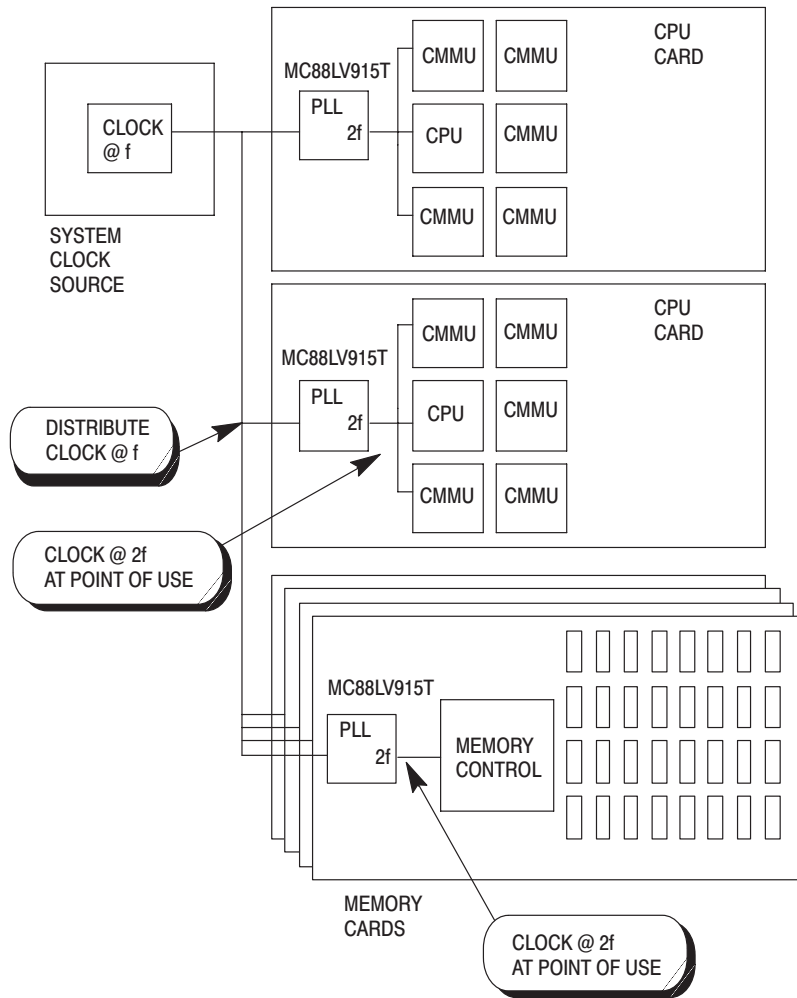

**Figure 4. Representation of a Potential Multi-Processing Application Utilizing the MC88LV915T for Frequency Multiplication and Low Board-to-Board Skew**

#### MC88LV915T System Level Testing Functionality

3-state functionality has been added to the 100MHz version of the MC88LV915T to ease system board testing. Bringing the  $\overline{OE/RST}$  pin low will put all outputs (except for LOCK) into the high impedance state. As long as the PLL\_EN pin is low, the Q0–Q4, Q5, and the Q/2 outputs will remain reset in the low state after the  $\overline{OE/RST}$  until a falling SYNC edge is seen. The 2X\_Q output will be the inverse of the SYNC signal in this mode. If the 3-state functionality will be used, a pull-up or pull-down resistor must be tied to the FEEDBACK input pin to prevent it from floating when the feedback output goes into high impedance.

With the PLL\_EN pin low the selected SYNC signal is gated directly into the internal clock distribution network, bypassing and disabling the VCO. In this mode the outputs are directly driven by the SYNC input (per the block diagram). This mode can also be used for low frequency board testing.

Note: If the outputs are put into 3-state during normal PLL operation, the loop will be broken and phase-lock will be lost. It will take a maximum of 10mS (tLOCK spec) to regain phase-lock after the  $\overline{OE/RST}$  pin goes back high.

# OUTLINE DIMENSIONS

## FN SUFFIX PLASTIC PACKAGE CASE 776-02 ISSUE D

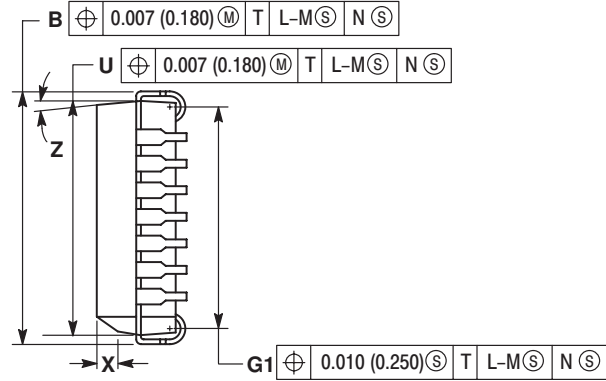
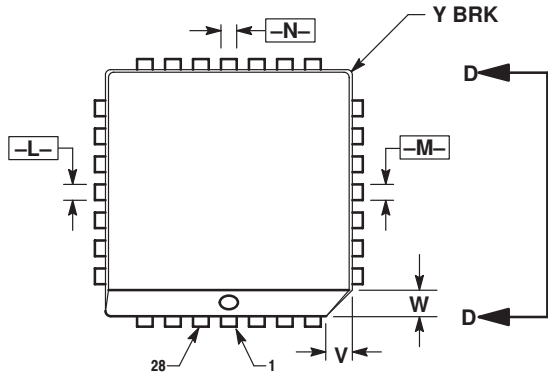

VIEW D-D

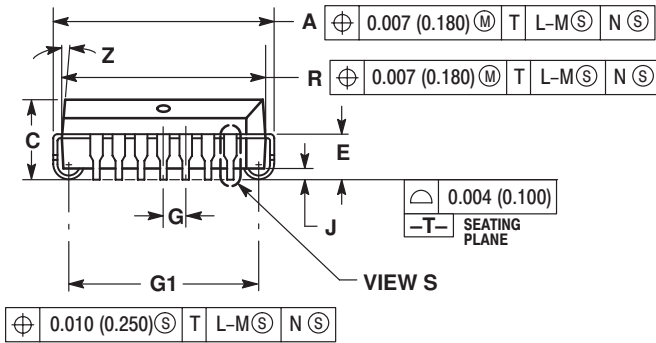

VIEW S

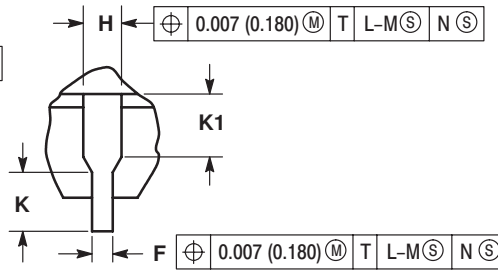

VIEW S

**NOTES:**

- DATUMS -L-, -M-, AND -N- DETERMINED WHERE TOP OF LEAD SHOULDER EXITS PLASTIC BODY AT MOLD PARTING LINE.
- DIMENSION G1, TRUE POSITION TO BE MEASURED AT DATUM -T-, SEATING PLANE.
- DIMENSIONS R AND U DO NOT INCLUDE MOLD FLASH. ALLOWABLE MOLD FLASH IS 0.010 (0.250) PER SIDE.
- DIMENSIONING AND TOLERANCING PER ANSI Y14.5M, 1982.
- CONTROLLING DIMENSION: INCH.
- THE PACKAGE TOP MAY BE SMALLER THAN THE PACKAGE BOTTOM BY UP TO 0.012 (0.300). DIMENSIONS R AND U ARE DETERMINED AT THE OUTERMOST EXTREMES OF THE PLASTIC BODY EXCLUSIVE OF MOLD FLASH, TIE BAR BURRS, GATE BURRS AND INTERLEAD FLASH, BUT INCLUDING ANY MISMATCH BETWEEN THE TOP AND BOTTOM OF THE PLASTIC BODY.
- DIMENSION H DOES NOT INCLUDE DAMBAR PROTRUSION OR INTRUSION. THE DAMBAR PROTRUSION(S) SHALL NOT CAUSE THE H DIMENSION TO BE GREATER THAN 0.037 (0.940). THE DAMBAR INTRUSION(S) SHALL NOT CAUSE THE H DIMENSION TO BE SMALLER THAN 0.025 (0.635).

DIM	INCHES		MILLIMETERS	
	MIN	MAX	MIN	MAX
A	0.485	0.495	12.32	12.57
B	0.485	0.495	12.32	12.57
C	0.165	0.180	4.20	4.57
E	0.090	0.110	2.29	2.79
F	0.013	0.019	0.33	0.48
G	0.050 BSC		1.27 BSC	
H	0.026	0.032	0.66	0.81
J	0.020	----	0.51	----
K	0.025	----	0.64	----
R	0.450	0.456	11.43	11.58
U	0.450	0.456	11.43	11.58
V	0.042	0.048	1.07	1.21
W	0.042	0.048	1.07	1.21
X	0.042	0.056	1.07	1.42
Y	----	0.020	----	0.50
Z	2°		10°	
G1	0.410	0.430	10.42	10.92
K1	0.040	----	1.02	----

## NOTES

Motorola reserves the right to make changes without further notice to any products herein. Motorola makes no warranty, representation or guarantee regarding the suitability of its products for any particular purpose, nor does Motorola assume any liability arising out of the application or use of any product or circuit, and specifically disclaims any and all liability, including without limitation consequential or incidental damages. "Typical" parameters which may be provided in Motorola data sheets and/or specifications can and do vary in different applications and actual performance may vary over time. All operating parameters, including "Typicals" must be validated for each customer application by customer's technical experts. Motorola does not convey any license under its patent rights nor the rights of others. Motorola products are not designed, intended, or authorized for use as components in systems intended for surgical implant into the body, or other applications intended to support or sustain life, or for any other application in which the failure of the Motorola product could create a situation where personal injury or death may occur. Should Buyer purchase or use Motorola products for any such unintended or unauthorized application, Buyer shall indemnify and hold Motorola and its officers, employees, subsidiaries, affiliates, and distributors harmless against all claims, costs, damages, and expenses, and reasonable attorney fees arising out of, directly or indirectly, any claim of personal injury or death associated with such unintended or unauthorized use, even if such claim alleges that Motorola was negligent regarding the design or manufacture of the part. Motorola and  are registered trademarks of Motorola, Inc. Motorola, Inc. is an Equal Opportunity/Affirmative Action Employer.

MOTOROLA and the Stylized M Logo are registered in the US Patent & Trademark Office. All other product or service names are the property of their respective owners. © Motorola, Inc. 2001.

**How to reach us:**

**USA/EUROPE/Locations Not Listed:** Motorola Literature Distribution; P.O. Box 5405, Denver, Colorado 80217. 1-303-675-2140 or 1-800-441-2447

**JAPAN:** Motorola Japan Ltd.; SPS, Technical Information Center, 3-20-1, Minami-Azabu. Minato-ku, Tokyo 106-8573 Japan. 81-3-3440-3569

**ASIA/PACIFIC:** Motorola Semiconductors H.K. Ltd.; Silicon Harbour Centre, 2 Dai King Street, Tai Po Industrial Estate, Tai Po, N.T., Hong Kong. 852-26668334

**Technical Information Center: 1-800-521-6274**

**HOME PAGE:** <http://www.motorola.com/semiconductors/>



**MOTOROLA**



**MC88LV915T/D**