



Chipsmall Limited consists of a professional team with an average of over 10 year of expertise in the distribution of electronic components. Based in Hongkong, we have already established firm and mutual-benefit business relationships with customers from,Europe,America and south Asia,supplying obsolete and hard-to-find components to meet their specific needs.

With the principle of “Quality Parts,Customers Priority,Honest Operation,and Considerate Service”,our business mainly focus on the distribution of electronic components. Line cards we deal with include Microchip,ALPS,ROHM,Xilinx,Pulse,ON,Everlight and Freescale. Main products comprise IC,Modules,Potentiometer,IC Socket,Relay,Connector.Our parts cover such applications as commercial,industrial, and automotives areas.

We are looking forward to setting up business relationship with you and hope to provide you with the best service and solution. Let us make a better world for our industry!



## Contact us

Tel: +86-755-8981 8866 Fax: +86-755-8427 6832

Email & Skype: info@chipsmall.com Web: www.chipsmall.com

Address: A1208, Overseas Decoration Building, #122 Zhenhua RD., Futian, Shenzhen, China



## Low Skew CMOS PLL 68060 Clock Driver

The MC88LV926 Clock Driver utilizes phase-locked loop technology to lock its low skew outputs' frequency and phase onto an input reference clock. It is designed to provide clock distribution for CISC microprocessor or single processor RISC systems. The RST\_IN/RST\_OUT(LOCK) pins provide a processor reset function designed specifically for the MC68/EC/LC030/040/060 microprocessor family. To support the 68060 processor, the 88LV926 operates from a 3.3V as well as a 5.0V supply.

The PLL allows the high current, low skew outputs to lock onto a single clock input and distribute it with essentially zero delay to multiple locations on a board. The PLL also allows the MC88LV926 to multiply a low frequency input clock and distribute it locally at a higher (2X) system frequency.

- 2X\_Q Output Meets All Requirements of the 50 and 66MHz 68060 Microprocessor PCLK Input Specifications
- Low Voltage 3.3V V<sub>CC</sub>
- Three Outputs (Q0-Q2) With Output-Output Skew <500ps
- CLKEN Output for Half Speed Bus Applications
- The Phase Variation From Part-to-Part Between SYNC and the 'Q' Outputs Is Less Than 600ps (Derived From the T<sub>PD</sub> Specification, Which Defines the Part-to-Part Skew)
- SYNC Input Frequency Range From 5MHz to 2X\_Q F<sub>Max</sub>/4
- All Outputs Have ±36mA Drive (Equal High and Low) CMOS Levels
- Can Drive Either CMOS or TTL Inputs. All Inputs Are TTL-Level Compatible with V<sub>CC</sub> = 3.3V
- Test Mode Pin (PLL\_EN) Provided for Low Frequency Testing

Three 'Q' outputs (Q0-Q2) are provided with less than 500ps skew between their rising edges. A 2X\_Q output runs at twice the 'Q' output frequency. The 2X\_Q output is ideal for 68060 systems which require a 2X processor clock input, and it meets the tight duty cycle spec of the 50 and 66MHz 68060. The QCLKEN output is designed to drive the CLKEN input of the 68060 when the bus logic runs at half of the microprocessor clock rate. The QCLKEN output is skewed relative to the 2X\_Q output to ensure that CLKEN setup and hold times of the 68060 are satisfied. A Q/2 frequency is fed back internally, providing a fixed 2X multiplication from the 'Q' outputs to the SYNC input. Since the feedback is done internally (no external feedback pin is provided) the input/output frequency relationships are fixed. The Q3 output provides an inverted clock output to allow flexibility in the clock tree design.

In normal phase-locked operation the PLL\_EN pin is held high. Pulling the PLL\_EN pin low disables the VCO and puts the 88LV926 in a static 'test mode'. In this mode there is no frequency limitation on the input clock, which is necessary for a low frequency board test environment.

The RST\_OUT(LOCK) pin doubles as a phase-lock indicator. When the RST\_IN pin is held high, the open drain RST\_OUT pin will be pulled actively low until phase-lock is achieved. When phase-lock occurs, the RST\_OUT(LOCK) is released and a pull-up resistor will pull the signal high. To give a processor reset signal, the RST\_IN pin is toggled low, and the RST\_OUT(LOCK) pin will stay low for 1024 cycles of the 'Q' output frequency after the RST\_IN pin is brought back high.

### Description of the RST\_IN/RST\_OUT(LOCK) Functionality

The RST\_IN and RST\_OUT(LOCK) pins provide a 68030/040/060 processor reset function, with the RST\_OUT pin also acting as a lock indicator. If the RST\_IN pin is held high during system power-up, the RST\_OUT pin will be in the low state until steady state phase/frequency lock to the input reference is achieved. 1024 'Q' output cycles after phase-lock is achieved the RST\_OUT(LOCK) pin will go into a high impedance state, allowing it to be pulled high by an external pull-up resistor (see the AC/DC specs for the characteristics of the RST\_OUT(LOCK) pin). If the RST\_IN pin is held low during power-up, the RST\_OUT(LOCK) pin will remain low.

**MC88LV926**

**LOW SKEW CMOS PLL  
68060 CLOCK DRIVER**

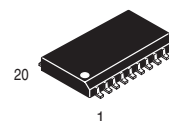

**DW SUFFIX**  
PLASTIC SOIC PACKAGE  
CASE 751D





Pinout: 20-Lead Wide SOIC Package (Top View)

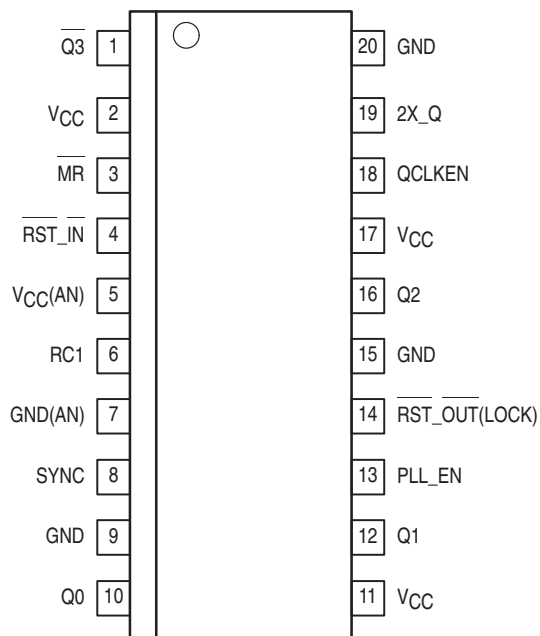

#### Description of the $\overline{\text{RST\_IN}}/\overline{\text{RST\_OUT(LOCK)}}$ Functionality (continued)

After the system start-up is complete and the 88LV926 is phase-locked to the SYNC input signal ( $\overline{\text{RST\_OUT}}$  high), the processor reset functionality can be utilized. When the  $\overline{\text{RST\_IN}}$  pin is toggled low (min. pulse width=10nS),  $\overline{\text{RST\_OUT(LOCK)}}$  will go to the low state and remain there for 1024 cycles of the 'Q' output frequency (512 SYNC cycles). During the time in which the  $\overline{\text{RST\_OUT(LOCK)}}$  is actively pulled low, all the 88LV926 clock outputs will continue operating correctly and in a locked condition to the SYNC input (clock signals to the 68030/040/060 family of processors must continue while the processor is in reset). A propagation delay after the 1024th cycle  $\overline{\text{RST\_OUT(LOCK)}}$  goes back to the high impedance state to be pulled high by the resistor.

#### Power Supply Ramp Rate Restriction for Correct 030/040 Processor Reset Operation During System Start-up

Because the  $\overline{\text{RST\_OUT(LOCK)}}$  pin is an indicator of

phase-lock to the reference source, some constraints must be placed on the power supply ramp rate to make sure the  $\overline{\text{RST\_OUT(LOCK)}}$  signal holds the processor in reset during system start-up (power-up). With the recommended loop filter values (see Figure 6.) the lock time is approximately 10ms. The phase-lock loop will begin attempting to lock to a reference source (if it is present) when VCC reaches 2V. If the VCC ramp rate is significantly slower than 10ms, then the PLL could lock to the reference source, causing  $\overline{\text{RST\_OUT(LOCK)}}$  to go high before the 88LV926 and '030/040 processor is fully powered up, violating the processor reset specification. Therefore, if it is necessary for the  $\overline{\text{RST\_IN}}$  pin to be held high during power-up, the VCC ramp rate must be less than 10mS for proper 68030/040/060 reset operation.

This ramp rate restriction can be ignored if the  $\overline{\text{RST\_IN}}$  pin can be held low during system start-up (which holds  $\overline{\text{RST\_OUT}}$  low). The  $\overline{\text{RST\_OUT(LOCK)}}$  pin will then be pulled back high 1024 cycles after the  $\overline{\text{RST\_IN}}$  pin goes high.

#### CAPACITANCE AND POWER SPECIFICATIONS

Symbol	Parameter	Value Typ	Unit	Test Conditions
C <sub>IN</sub>	Input Capacitance	4.5*	pF	V <sub>CC</sub> = 5.0V
C <sub>PD</sub>	Power Dissipation Capacitance	40*	pF	V <sub>CC</sub> = 5.0V
PD <sub>1</sub>	Power Dissipation at 33MHz With 50Ω Thevenin Termination	15mW/Output* 90mW/Device	mW	V <sub>CC</sub> = 5.0V T = 25°C
PD <sub>2</sub>	Power Dissipation at 33MHz With 50Ω Parallel Termination to GND	37.5mW/Output* 225mW/Device	mW	V <sub>CC</sub> = 5.0V T = 25°C

\* Value at V<sub>CC</sub> = 3.3V TBD.

## MAXIMUM RATINGS\*

Symbol	Parameter	Limits	Unit
$V_{CC}$ , $AV_{CC}$	DC Supply Voltage Referenced to GND	-0.5 to 7.0	V
$V_{in}$	DC Input Voltage (Referenced to GND)	-0.5 to $V_{CC} + 0.5$	V
$V_{out}$	DC Output Voltage (Referenced to GND)	-0.5 to $V_{CC} + 0.5$	V
$I_{in}$	DC Input Current, Per Pin	$\pm 20$	mA
$I_{out}$	DC Output Sink/Source Current, Per Pin	$\pm 50$	mA
$I_{CC}$	DC $V_{CC}$ or GND Current Per Output Pin	$\pm 50$	mA
$T_{stg}$	Storage Temperature	-65 to +150	$^{\circ}C$

\* Maximum Ratings are those values beyond which damage to the device may occur. Functional operation should be restricted to the Recommended Operating Conditions.

## RECOMMENDED OPERATING CONDITIONS

Symbol	Parameter	Limits	Unit
$V_{CC}$	Supply Voltage	$3.3 \pm 0.3$	V
$V_{in}$	DC Input Voltage	0 to $V_{CC}$	V
$V_{out}$	DC Output Voltage	0 to $V_{CC}$	V
$T_A$	Ambient Operating Temperature	0 to 70	$^{\circ}C$
ESD	Static Discharge Voltage	> 1500	V

DC CHARACTERISTICS ( $T_A = 0^{\circ}C$  to  $70^{\circ}C$ ;  $V_{CC} = 3.3V \pm 0.3V$ )<sup>4</sup>

Symbol	Parameter	$V_{CC}$	Guaranteed Limits	Unit	Condition
$V_{IH}$	Minimum High Level Input Voltage <sup>4</sup>	3.0 3.3	2.0 2.0	V	$V_{OUT} = 0.1V$ or $V_{CC} - 0.1V$
$V_{IL}$	Minimum Low Level Input Voltage	3.0 3.3	0.8 0.8	V	$V_{OUT} = 0.1V$ or $V_{CC} - 0.1V$
$V_{OH}$	Minimum High Level Output Voltage	3.0 3.3	2.2 2.5	V	$V_{IN} = V_{IH}$ or $V_{IL}$ $I_{OH} \quad -24mA$ $\quad \quad -24mA$
$V_{OL}$	Minimum Low Level Output Voltage	3.0 3.3	0.55 0.55	V	$V_{IN} = V_{IH}$ or $V_{IL}$ $I_{OH} \quad +24mA$ <sup>1</sup> $\quad \quad +24mA$
$I_{IN}$	Maximum Input Leakage Current	3.3	$\pm 1.0$	$\mu A$	$V_I = V_{CC}, GND$
$I_{CCT}$	Maximum $I_{CC}/Input$	3.3	2.0 <sup>2</sup>	mA	$V_I = V_{CC} - 2.1V$
$I_{OLD}$	Minimum Dynamic <sup>3</sup> Output Current	3.3	50	mA	$V_{OLD} = 1.25V$ Max
$I_{OHD}$		3.3	-50	mA	$V_{OHD} = 2.35$ Min
$I_{CC}$	Maximum Quiescent Supply Current	3.3	750	$\mu A$	$V_I = V_{CC}, GND$

1.  $I_{OL}$  is +12mA for the RST\_OUT output.

2. The PLL\_EN input pin is not guaranteed to meet this specification.

3. Maximum test duration 2.0ms, one output loaded at a time.

4. The MC88LV926 can also be operated from a 5.0V supply.  $V_{OH}$  output levels will vary 1:1 with  $V_{CC}$ , input levels and current specs will be unchanged, except  $V_{IH}$ ; when  $V_{CC} > 4.0$  volts,  $V_{IH}$  minimum level is 2.7 volts.

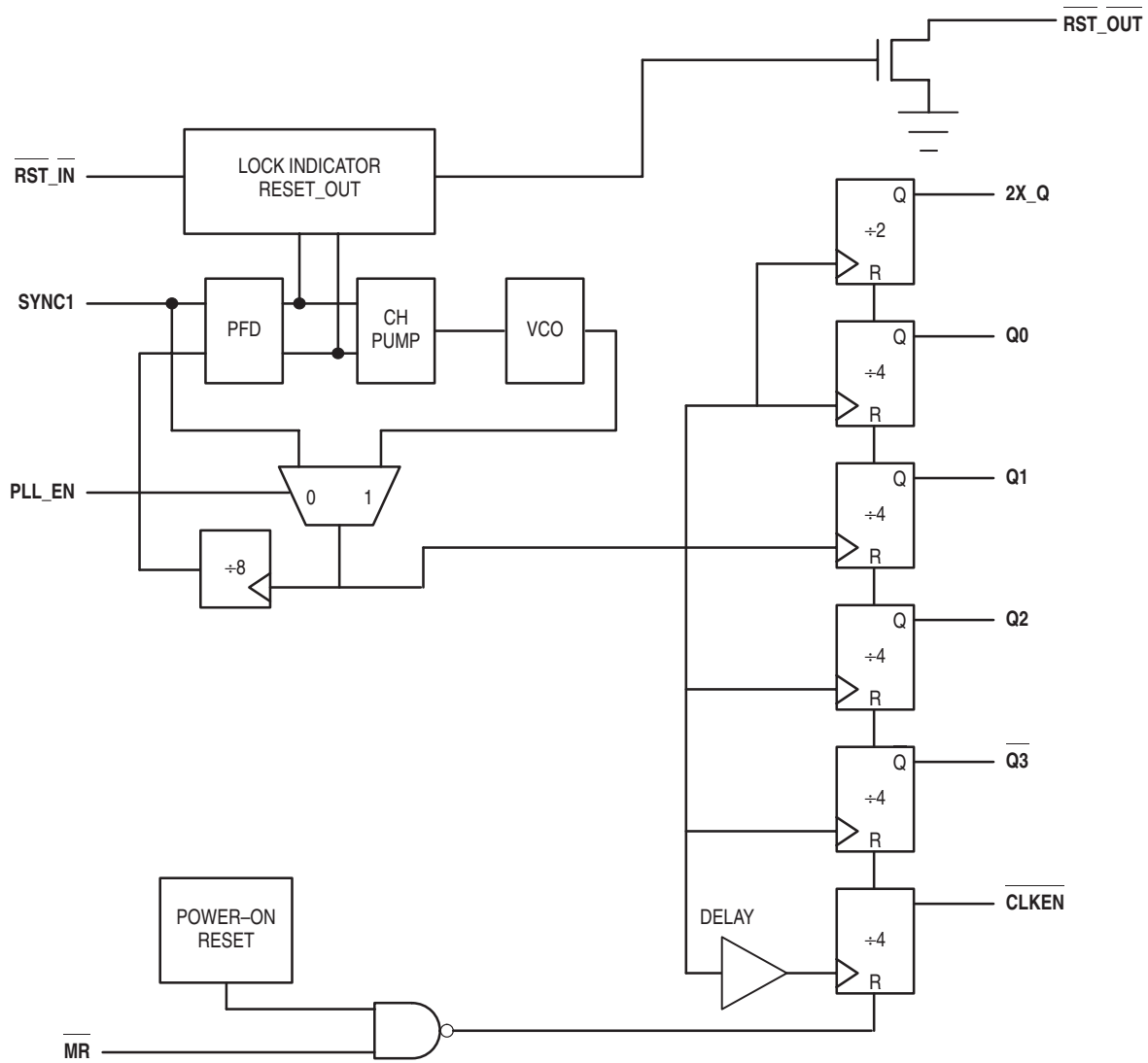

Figure 1. MC88LV926 Logic Block Diagram

**SYNC INPUT TIMING REQUIREMENTS**

Symbol	Parameter	Minimum	Maximum	Unit
tRISE/FALL SYNC Input	Rise/Fall Time, SYNC Input From 0.8V to 2.0V	—	5.0	ns
tCYCLE, SYNC Input	Input Clock Period SYNC Input <sup>1</sup>	$\frac{1}{f_{2X\_Q}/4}$	200 <sup>1</sup>	ns
Duty Cycle	Duty Cycle, SYNC Input	50% ± 25%		

1. When V<sub>CC</sub> > 4.0 volts, Maximum SYNC Input Period is 125ns.

**FREQUENCY SPECIFICATIONS (T<sub>A</sub> = 0°C to 70°C; V<sub>CC</sub> = 3.3V ± 0.3V or 5.0V ± 5%)**

Symbol	Parameter	Guaranteed Minimum	Unit
Fmax (2X_Q)	Maximum Operating Frequency, 2X_Q Output	66	MHz
Fmax ('Q')	Maximum Operating Frequency, Q0–Q3 Outputs	33	MHz

Maximum Operating Frequency is guaranteed with the 88LV926 in a phase-locked condition.

AC CHARACTERISTICS ( $T_A = 0^\circ\text{C}$  to  $70^\circ\text{C}$ ;  $V_{CC} = 3.3\text{V} \pm 0.3\text{V}$  or  $5.0\text{V} \pm 5\%$ )

Symbol	Parameter	Minimum	Maximum	Unit	Condition
$t_{RISE/FALL}$ All Outputs	Rise/Fall Time, into $50\Omega$ Load	0.3	1.6	ns	$t_{RISE} - 0.8\text{V}$ to $2.0\text{V}$ $t_{FALL} - 2.0\text{V}$ to $0.8\text{V}$
$t_{RISE/FALL}$ $2X\_Q$ Output	Rise/Fall Time into a $50\Omega$ Load	0.5	1.6	ns	$t_{RISE} - 0.8\text{V}$ to $2.0\text{V}$ $t_{FALL} - 2.0\text{V}$ to $0.8\text{V}$
$t_{pulse\ width(a)}^1$ (Q0, Q1, Q2, Q3)	Output Pulse Width Q0, Q1, Q2, Q3 at $1.65\text{V}$	$0.5t_{cycle} - 0.5$	$0.5t_{cycle} + 0.5$	ns	$50\Omega$ Load Terminated to $V_{CC}/2$ (See Application Note 3)
$t_{pulse\ width(b)}^1$ ( $2X\_Q$ Output)	Output Pulse Width $2X\_Q$ at $1.65\text{V}$	$0.5t_{cycle} - 0.5$	$0.5t_{cycle} + 0.5$	ns	$50\Omega$ Load Terminated to $V_{CC}/2$ (See Application Note 3)
$t_{SKEW_r}^2$ (Rising)	Output-to-Output Skew Between Outputs Q0-Q2 (Rising Edge Only)	—	500	ps	Into a $50\Omega$ Load Terminated to $V_{CC}/2$ (See Timing Diagram in Figure 5.)
$t_{SKEW_f}^2$ (Falling)	Output-to-Output Skew Between Outputs Q0-Q2 (Falling Edge Only)	—	1.0	ns	Into a $50\Omega$ Load Terminated to $V_{CC}/2$ (See Timing Diagram in Figure 5.)
$t_{SKEW_{all}}^2$	Output-to-Output Skew $2X\_Q$ , Q0-Q2, Q3	—	750	ps	Into a $50\Omega$ Load Terminated to $V_{CC}/2$ (See Timing Diagram in Figure 5.)
$t_{SKEW\ QCLKEN}^{1,2}$	Output-to-Output Skew QCLKEN to $2X\_Q$ $2X\_Q = 50\text{MHz}$ $2X\_Q = 66\text{MHz}$	$9.7^6$ $7.0^6$	—	ns	Into a $50\Omega$ Load Terminated to $V_{CC}/2$ (See Timing Diagram in Figure 5.)
$t_{LOCK}^3$	Phase-Lock Acquisition Time, All Outputs to SYNC Input	1	10	ms	
$t_{PHL\ MR - Q}^1$	Propagation Delay, MR to Any Output (High-Low)	1.5	13.5	ns	Into a $50\Omega$ Load Terminated to $V_{CC}/2$
$t_{REC, MR\ to\ SYNC}^{5, 1}$	Reset Recovery Time rising MR edge to falling SYNC edge	9	—	ns	
$t_{W, MR\ LOW}^{5, 1}$	Minimum Pulse Width, MR input Low	5	—	ns	
$t_{W, RST\_IN\ LOW}^1$	Minimum Pulse Width, RST_IN Low	10	—	ns	When in Phase-Lock
$t_{PZL}^1$	Output Enable Time _____ RST_IN Low to RST_OUT Low	1.5	16.5	ns	See Application Note 5
$t_{PLZ}^1$	Output Enable Time _____ RST_IN High to RST_OUT High Z	1016 'Q' Cycles (508 Q/2 Cycles)	1024 'Q' Cycles (512 Q/2 Cycles)	ns	See Application Note 5

1. These specifications are not tested, they are guaranteed by statistical characterization. See Application Note 1 for a discussion of this methodology.

2. Under equally loaded conditions and at a fixed temperature and voltage.

3. With  $V_{CC}$  fully powered-on:  $t_{CLOCK}$  Max is with  $C1 = 0.1\mu\text{F}$ ;  $t_{LOCK}$  Min is with  $C1 = 0.01\mu\text{F}$ .

4. See Application Note 4 for the distribution in time of each output referenced to SYNC.

5. Specification is valid only when the PLL\_EN pin is low.

6. Guaranteed that QCLKEN will meet the setup and hold time requirement of the 68060.

Application Notes

1. Several specifications can only be measured when the MC88LV926 is in phase-locked operation. It is not possible to have the part in phase-lock on ATE (automated test equipment). Statistical characterization techniques were used to guarantee those specifications which cannot be measured on the ATE. MC88LV926 units were fabricated with key transistor properties intentionally varied to create a 14 cell designed experimental matrix. IC performance was characterized over a range of transistor properties (represented by the 14 cells) in excess of the expected process variation of the wafer fabrication area. Response Surface Modeling (RSM) techniques were used to relate IC performance to the CMOS transistor properties over operation voltage and temperature. IC performance to each specification and fab variation were used in conjunction with Yield Surface Modeling™ (YSM™) methodology to set performance limits of ATE testable specifications within those which are to be guaranteed by statistical characterization. In this way, all units passing the ATE test will meet or exceed the non-tested specifications limits.

2. A 470KΩ resistor tied to either Analog VCC or Analog GND, as shown in Figure 2., is required to ensure no jitter is present on the MC88LV926 outputs. This technique causes a phase offset between the SYNC input and the Q0 output, measured at the pins. The t<sub>PD</sub> spec describes how this offset varies with process, temperature, and voltage. The specs were arrived at by measuring the phase relationship for the 14 lots described in note 1 while the part was in phase-locked operation. The actual measurements were made with a 10MHz SYNC input (1.0ns edge rate from 0.8V to 2.0V). The phase measurements were made at 1.5V. See Figure 2. for a graphical description.

3. Two specs (t<sub>RISE/FALL</sub> and t<sub>PULSE</sub> Width 2X\_Q output, see AC Specifications) guarantee that the MC88LV926 meets the 33MHz and 66MHz 68060 P-Clock input specification.

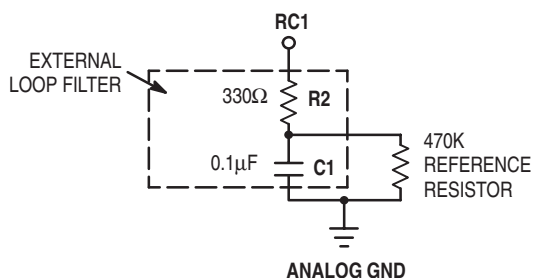

WITH THE 470KΩ RESISTOR TIED IN THIS FASHION THE T<sub>PD</sub> SPECIFICATION, MEASURED AT THE INPUT PINS IS:

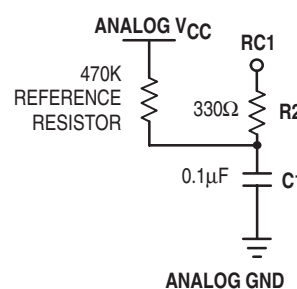
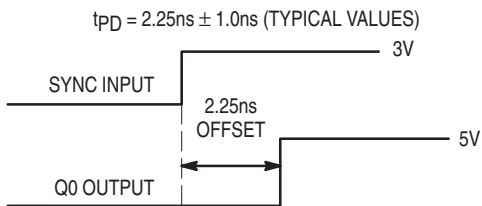

WITH THE 470KΩ RESISTOR TIED IN THIS FASHION THE T<sub>PD</sub> SPECIFICATION, MEASURED AT THE INPUT PINS IS:

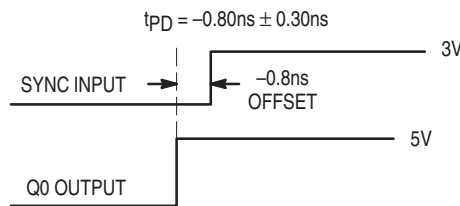

Figure 2. Depiction of the Fixed SYNC to Q0 Offset (t<sub>PD</sub>) Which Is Present When a 470KΩ Resistor Is Tied to V<sub>CC</sub> or Ground

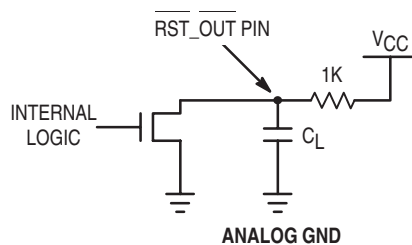

Figure 3. RST\_OUT Test Circuit

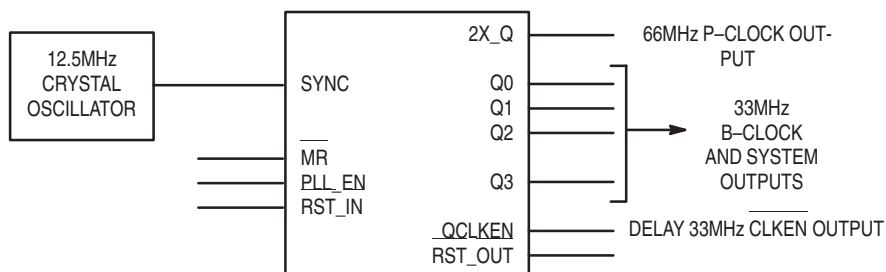

Figure 4. Logical Representation of the MC88LV926 With Input/Output Frequency Relationships

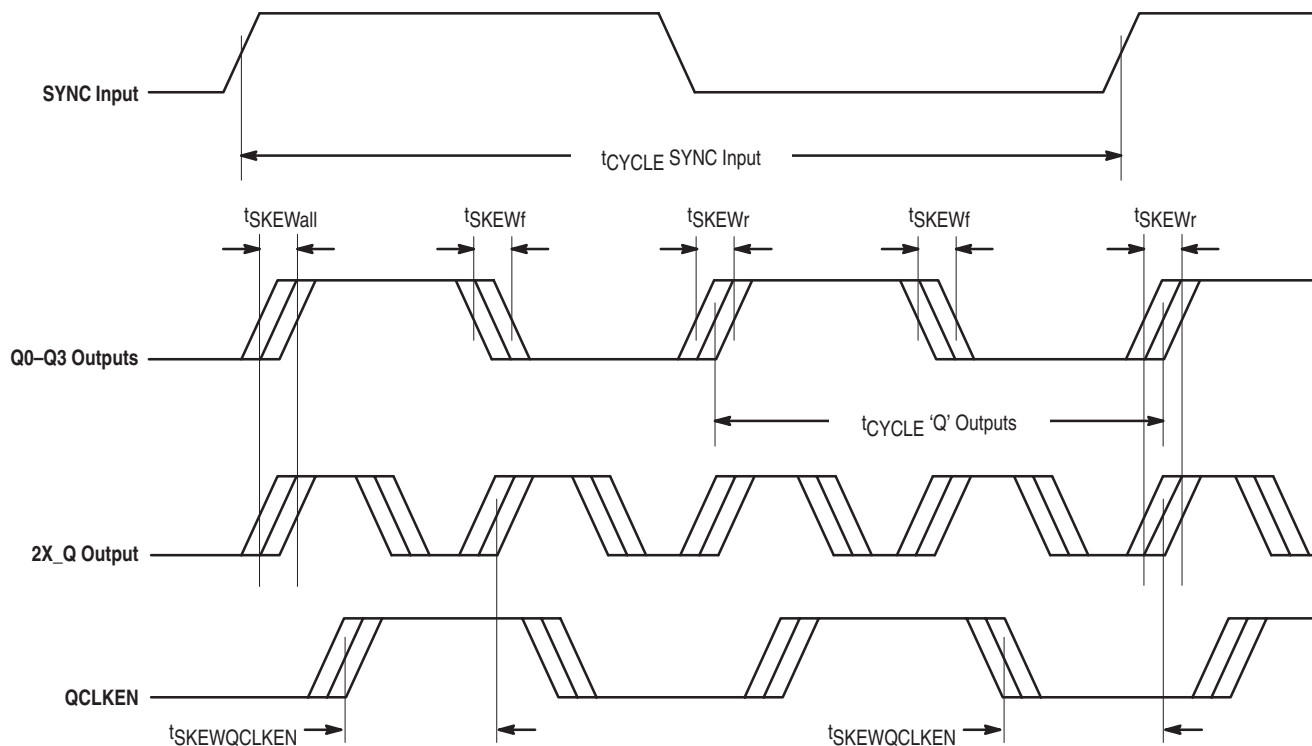

Figure 5. Output/Input Switching Waveforms and Timing Relationships

### Timing Notes

1. The MC88LV926 aligns rising edges of the outputs and the SYNC input, therefore the SYNC input does not require a 50% duty cycle.
2. All skew specs are measured between the  $V_{CC}/2$  crossing point of the appropriate output edges. All skews are specified as 'windows', not as a  $\pm$  deviation around a center point.



The  $t_{PD}$  spec includes the full temperature range from 0°C to 70°C and the full  $V_{CC}$  range from 3.0V to 3.3V. If the  $\Delta T$  and  $\Delta V_{CC}$  in a given system are less than the specification limits, the  $t_{PD}$  spec window will be reduced. The  $t_{PD}$  window for a given  $\Delta T$  and  $\Delta V_{CC}$  is given by the following regression formula:

TBD

- The  $\overline{RST\_OUT}$  pin is an open drain N-Channel output. Therefore an external pull-up resistor must be provided to pull up the  $\overline{RST\_OUT}$  pin when it goes into the high impedance state (after the MC88LV926 is phase-locked to the reference input with  $RST\_IN$  held high or 1024 'Q' cycles after the  $RST\_IN$  pin goes high when the part is locked). In the  $t_{pLZ}$  and  $t_{pZL}$  specifications, a 1K $\Omega$  resistor is used as a pull-up as shown in Figure 3.

### Notes Concerning Loop Filter and Board Layout Issues

- Figure 6. shows a loop filter and analog isolation scheme which will be effective in most applications. The following guidelines should be followed to ensure stable and jitter-free operation:
  - All loop filter and analog isolation components should be tied as close to the package as possible. Stray current passing through the parasitics of long traces can cause undesirable voltage transients at the RC1 pin.
  - The 47 $\Omega$  resistors, the 10 $\mu F$  low frequency bypass capacitor, and the 0.1 $\mu F$  high frequency bypass capacitor form a wide bandwidth filter that will make the 88LV926 PLL insensitive to voltage transients from the system digital  $V_{CC}$  supply and ground planes. This filter will typically ensure that a 100mV step deviation on the digital  $V_{CC}$  supply will cause no more than a 100ps phase deviation on the 88LV926 outputs. A 250mV step deviation on  $V_{CC}$  using the recommended filter values will cause no more than a 250ps phase deviation; if a 25 $\mu F$  bypass capacitor is used (instead of 10 $\mu F$ ) a 250mV  $V_{CC}$  step will cause no more than a 100ps phase deviation.

If good bypass techniques are used on a board design near components which may cause digital  $V_{CC}$  and ground noise, the above described  $V_{CC}$  step deviations should not occur at the 88LV926's digital  $V_{CC}$  supply. The

- purpose of the bypass filtering scheme shown in Figure 6. is to give the 88LV926 additional protection from the power supply and ground plane transients that can occur in a high frequency, high speed digital system.
  - There are no special requirements set forth for the loop filter resistors (470K and 330 $\Omega$ ). The loop filter capacitor (0.1 $\mu F$ ) can be a ceramic chip capacitor, the same as a standard bypass capacitor.
  - The 470K reference resistor injects current into the internal charge pump of the PLL, causing a fixed offset between the outputs and the SYNC input. This also prevents excessive jitter caused by inherent PLL dead-band. If the VCO (2X\_Q output) is running above 40MHz, the 470K resistor provides the correct amount of current injection into the charge pump (2–3 $\mu A$ ). If the VCO is running below 40MHz, a 1M $\Omega$  reference resistor should be used (instead of 470K).
- In addition to the bypass capacitors used in the analog filter of Figure 6., there should be a 0.1 $\mu F$  bypass capacitor between each of the other (digital) four  $V_{CC}$  pins and the board ground plane. This will reduce output switching noise caused by the 88LV926 outputs, in addition to reducing potential for noise in the 'analog' section of the chip. These bypass capacitors should also be tied as close to the 88LV926 package as possible.

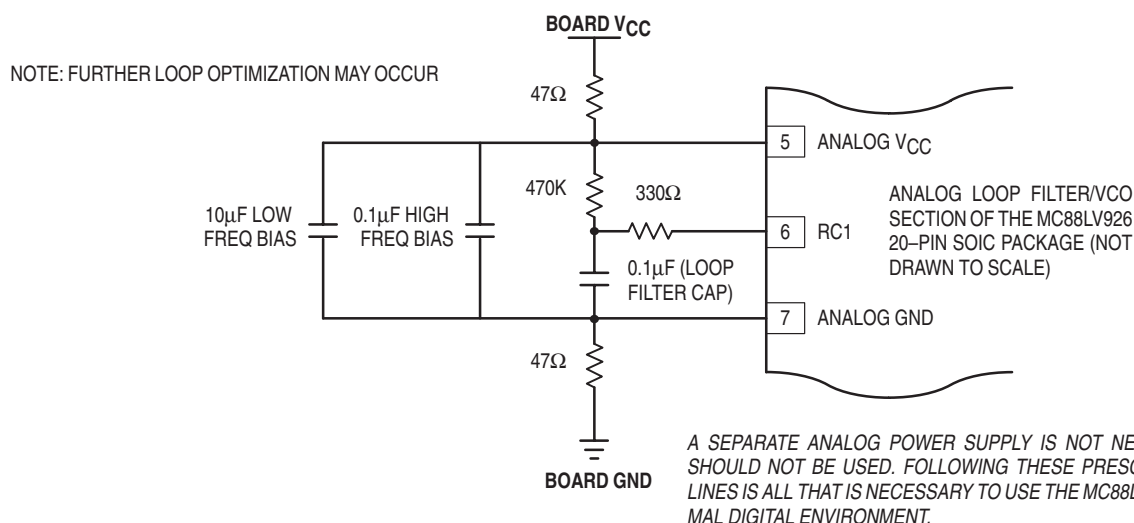

Figure 6. Recommended Loop Filter and Analog Isolation Scheme for the MC88LV926

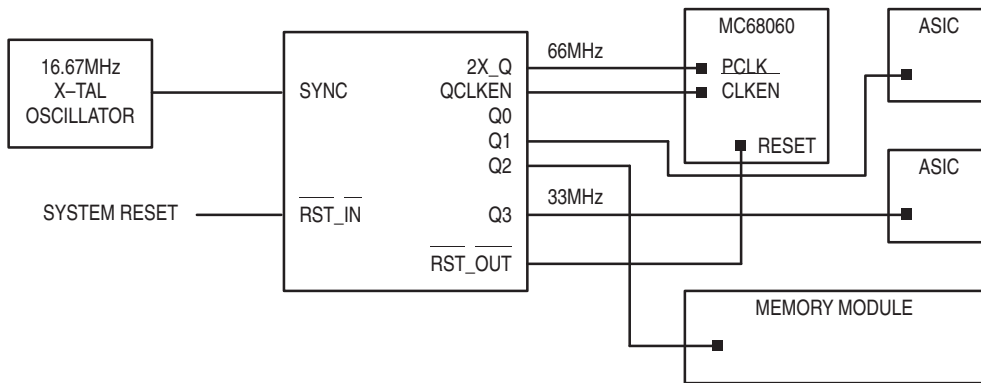
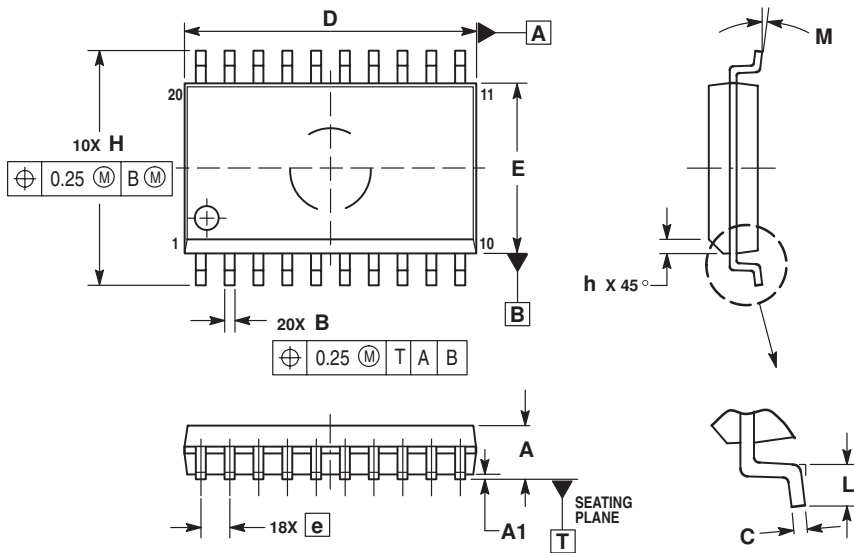

Figure 7. Typical MC88LV926/MC68060 System Configuration

OUTLINE DIMENSIONS

DW SUFFIX  
SOIC PACKAGE  
CASE 751D-06  
ISSUE G



- NOTES:
1. DIMENSIONS ARE IN MILLIMETERS.
  2. INTERPRET DIMENSIONS AND TOLERANCES PER ASME Y14.5M, 1994.
  3. DIMENSIONS D AND E DO NOT INCLUDE MOLD PROTRUSION.
  4. MAXIMUM MOLD PROTRUSION 0.15 PER SIDE.
  5. DIMENSION B DOES NOT INCLUDE DAMBAR PROTRUSION. ALLOWABLE PROTRUSION SHALL BE 0.13 TOTAL IN EXCESS OF B DIMENSION AT MAXIMUM MATERIAL CONDITION.

MILLIMETERS		
DIM	MIN	MAX
A	2.35	2.65
A1	0.10	0.25
B	0.35	0.49
C	0.23	0.32
D	12.65	12.95
E	7.40	7.60
e	1.27 BSC	
H	10.05	10.55
h	0.25	0.75
L	0.40	1.00
θ	0°	7°

## NOTES

Motorola reserves the right to make changes without further notice to any products herein. Motorola makes no warranty, representation or guarantee regarding the suitability of its products for any particular purpose, nor does Motorola assume any liability arising out of the application or use of any product or circuit, and specifically disclaims any and all liability, including without limitation consequential or incidental damages. "Typical" parameters which may be provided in Motorola data sheets and/or specifications can and do vary in different applications and actual performance may vary over time. All operating parameters, including "Typicals" must be validated for each customer application by customer's technical experts. Motorola does not convey any license under its patent rights nor the rights of others. Motorola products are not designed, intended, or authorized for use as components in systems intended for surgical implant into the body, or other applications intended to support or sustain life, or for any other application in which the failure of the Motorola product could create a situation where personal injury or death may occur. Should Buyer purchase or use Motorola products for any such unintended or unauthorized application, Buyer shall indemnify and hold Motorola and its officers, employees, subsidiaries, affiliates, and distributors harmless against all claims, costs, damages, and expenses, and reasonable attorney fees arising out of, directly or indirectly, any claim of personal injury or death associated with such unintended or unauthorized use, even if such claim alleges that Motorola was negligent regarding the design or manufacture of the part. Motorola and  are registered trademarks of Motorola, Inc. Motorola, Inc. is an Equal Opportunity/Affirmative Action Employer.

**How to reach us:**

**USA/EUROPE/Locations Not Listed:** Motorola Literature Distribution;  
P.O. Box 5405, Denver, Colorado 80217. 1-303-675-2140 or 1-800-441-2447

**JAPAN:** Motorola Japan Ltd.; SPS, Technical Information Center, 3-20-1,  
Minami-Azabu, Minato-ku, Tokyo 106-8573 Japan. 81-3-3440-3569

**Technical Information Center: 1-800-521-6274**

**ASIA/PACIFIC:** Motorola Semiconductors H.K. Ltd.; Silicon Harbour Centre,  
2, Dai King Street, Tai Po Industrial Estate, Tai Po, N.T., Hong Kong.  
852-26668334

**HOME PAGE:** <http://www.motorola.com/semiconductors/>