



Chipsmall Limited consists of a professional team with an average of over 10 year of expertise in the distribution of electronic components. Based in Hongkong, we have already established firm and mutual-benefit business relationships with customers from,Europe,America and south Asia,supplying obsolete and hard-to-find components to meet their specific needs.

With the principle of “Quality Parts,Customers Priority,Honest Operation,and Considerate Service”,our business mainly focus on the distribution of electronic components. Line cards we deal with include Microchip,ALPS,ROHM,Xilinx,Pulse,ON,Everlight and Freescale. Main products comprise IC,Modules,Potentiometer,IC Socket,Relay,Connector.Our parts cover such applications as commercial,industrial, and automotives areas.

We are looking forward to setting up business relationship with you and hope to provide you with the best service and solution. Let us make a better world for our industry!



Contact us

Tel: +86-755-8981 8866 Fax: +86-755-8427 6832

Email & Skype: info@chipsmall.com Web: www.chipsmall.com

Address: A1208, Overseas Decoration Building, #122 Zhenhua RD., Futian, Shenzhen, China





MCF5275 Integrated Microprocessor Family Hardware Specification

by: Microcontroller Solutions Group

The MCF5275 family is a highly integrated implementation of the ColdFire[®] family of reduced instruction set computing (RISC) microprocessors. This document describes pertinent features and functions characteristics of the MCF5275 family. The MCF5275 family includes the MCF5275, MCF5275L, MCF5274 and MCF5274L microprocessors. The differences between these parts are summarized in [Table 1](#). This document is written from the perspective of the MCF5275 and unless otherwise noted, the information applies also to the MCF5275L, MCF5274 and MCF5274L.

The MCF5275 family delivers a new level of performance and integration on the popular version 2 ColdFire core with up to 159 (Dhrystone 2.1) MIPS @ 166MHz. These highly integrated microprocessors build upon the widely used peripheral mix on the popular MCF5272 ColdFire microprocessor (10/100 Mbps Ethernet MAC and USB device) by adding a second 10/100 Mbps Ethernet MAC (MCF5274 and MCF5275) and hardware encryption (MCF5275L and MCF5275).

Contents

1	MCF5275 Family Configurations	2
2	Block Diagram	3
3	Features	3
4	Signal Descriptions	4
5	Design Recommendations	9
6	Mechanicals/Pinouts	14
7	Ordering Information	18
8	Electrical Characteristics	18
9	Documentation	43
10	Revision History	43

MCF5275 Family Configurations

In addition, the MCF5275 family features an enhanced multiply accumulate unit (EMAC), large on-chip memory (64 Kbytes SRAM, 16 Kbytes configurable cache), and a 16-bit DDR SDRAM memory controller.

These devices are ideal for cost-sensitive applications requiring significant control processing for file management, connectivity, data buffering, and user interface, as well as signal processing in a variety of key markets such as security, imaging, networking, gaming, and medical. This leading package of integration and high performance allows fast time to market through easy code reuse and extensive third party tool support.

To locate any published errata or updates for this document, refer to the ColdFire products website at <http://www.freescale.com/coldfire>.

1 MCF5275 Family Configurations

Table 1. MCF5275 Family Configurations

Module	MCF5274L	MCF5275L	MCF5274	MCF5275
ColdFire Version 2 Core with EMAC (Enhanced Multiply-Accumulate Unit)	•	•	•	•
System Clock	up to 166 MHz			
Performance (Dhrystone 2.1 MIPS)	up to 159			
Instruction/Data Cache	16 Kbytes (configurable)			
Static RAM (SRAM)	64 Kbytes			
Interrupt Controllers (INTC)	2	2	2	2
Edge Port Module (EPORT)	•	•	•	•
External Interface Module (EIM)	•	•	•	•
4-channel Direct-Memory Access (DMA)	•	•	•	•
DDR SDRAM Controller	•	•	•	•
Fast Ethernet Controller (FEC)	1	1	2	2
Watchdog Timer Module (WDT)	•	•	•	•
4-channel Programmable Interval Timer Module (PIT)	•	•	•	•
32-bit DMA Timers	4	4	4	4
USB	•	•	•	•
QSPI	•	•	•	•
UART(s)	3	3	3	3
I ² C	•	•	•	•
PWM	4	4	4	4
General Purpose I/O Module (GPIO)	•	•	•	•
CIM = Chip Configuration Module + Reset Controller Module	•	•	•	•
Debug BDM	•	•	•	•
JTAG - IEEE 1149.1 Test Access Port	•	•	•	•
Hardware Encryption	—	•	—	•
Package	196 MAPBGA		256 MAPBGA	

2 Block Diagram

The superset device in the MCF5275 family comes in a 256 Mold Array Plastic Ball Grid Array (MAPBGA) package. [Figure 1](#) shows a top-level block diagram of the MCF5275, the superset device.

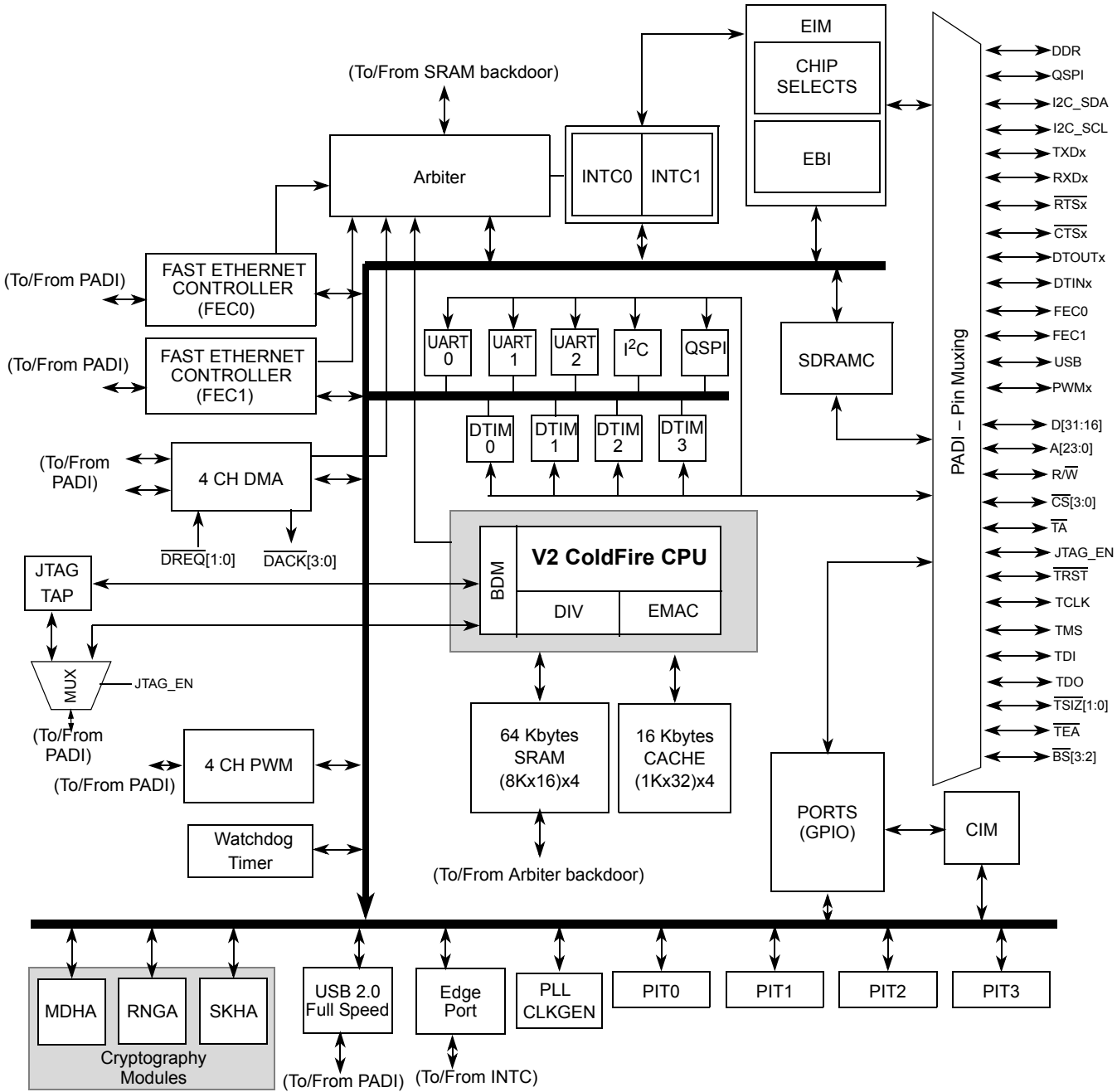

Figure 1. MCF5275 Block Diagram

3 Features

For a detailed feature list see the *MCF5275 Reference Manual* (MCF5275RM).

4 Signal Descriptions

This section describes signals that connect off chip, including a table of signal properties. For a more detailed discussion of the MCF5275 signals, consult the *MCF5275 Reference Manual* (MCF5275RM).

Table 2 lists the signals for the MCF5275 in functional group order. The “Dir” column is the direction for the primary function of the pin. Refer to Section 6, “Mechanicals/Pinouts,” for package diagrams.

NOTE

In this table and throughout this document a single signal within a group is designated without square brackets (i.e., A24), while designations for multiple signals within a group use brackets (i.e., A[23:21]) and is meant to include all signals within the two bracketed numbers when these numbers are separated by a colon.

NOTE

The primary functionality of a pin is not necessarily its default functionality. Pins that are muxed with GPIO will default to their GPIO functionality.

Table 2. MCF5274 and MCF5275 Signal Information and Muxing

Signal Name	GPIO	Alternate1	Alternate2	Dir. ¹	MCF5274 MCF5275 256 MAPBGA	MCF5274L MCF5275L 196 MAPBGA
Reset						
$\overline{\text{RESET}}$	—	—	—	I	N15	K12
RSTOUT	—	—	—	O	N14	L12
Clock						
EXTAL	—	—	—	I	L16	M14
XTAL	—	—	—	O	M16	N14
CLKOUT	—	—	—	O	T12	P9
Mode Selection						
CLKMOD[1:0]	—	—	—	I	N13, P13	M11, N11
$\overline{\text{RCON}}$	—	—	—	I	P8	M6
External Memory Interface and Ports						
A[23:21]	PADDR[7:5]	$\overline{\text{CS}}[6:4]$	—	O	A11, B11, C11	A8, B8, C8
A[20:0]	—	—	—	O	A12, B12, C12, A13, B13, C13, A14, B14, C14, B15, C15, B16, C16, D14, D15, E14:16, F14:16	B9, D9, C9, C10, B10, A11, C11, B11, A12, D11, C12, B13, C13, D12, E11, D13, E12, F11, D14, E13, F13

Table 2. MCF5274 and MCF5275 Signal Information and Muxing (continued)

Signal Name	GPIO	Alternate1	Alternate2	Dir. ¹	MCF5274 MCF5275 256 MAPBGA	MCF5274L MCF5275L 196 MAPBGA
D[31:16]	—	—	—	O	M1, N1, N2, N3, P1, P2, R1, R2, P3, R3, T3, N4, P4, R4, T4, N5	J3, L1, K2, K3, M1, L2, L3, L4, K4, J4, M2, N1, N2, M3, M4, N3
\overline{BS} [3:2]	\overline{PBS} [3:2]	\overline{CAS} [3:2]	—	O	M3, R5	K1, L5
\overline{OE}	PBUSCTL[7]	—	—	O	K1	H4
\overline{TA}	PBUSCTL[6]	—	—	I	L13	K14
\overline{TEA}	PBUSCTL[5]	$\overline{DREQ1}$	—	I	T8	—
R/ \overline{W}	PBUSCTL[4]	—	—	O	P7	L6
TSIZ1	PBUSCTL[3]	DACK1	—	O	D16	B14
TSIZ0	PBUSCTL[2]	DACK0	—	O	G16	E14
\overline{TS}	PBUSCTL[1]	DACK2	—	O	L4	H2
\overline{TIP}	PBUSCTL[0]	$\overline{DREQ0}$	—	O	P6	—
Chip Selects						
\overline{CS} [7:1]	PCS[7:1]	—	—	O	D10:13, E13, F13, N7	D8, A9, A10, D10, B12, C14, P4
$\overline{CS0}$	—	—	—	O	R6	N5
DDR SDRAM Controller						
DDR_CLKOUT	—	—	—	O	T7	P6
$\overline{DDR_CLKOUT}$	—	—	—	O	T6	P5
$\overline{SD_CS}$ [1:0]	PSDRAM[7:6]	\overline{CS} [3:2]	—	O	M2, T5	H3, M5
$\overline{SD_SRAS}$	PSDRAM[5]	—	—	O	L2	H1
$\overline{SD_SCAS}$	PSDRAM[4]	—	—	O	L1	G3
$\overline{SD_WE}$	PSDRAM[3]	—	—	O	K2	G4
SD_A10	—	—	—	O	N6	N4
$\overline{SD_DQS}$ [3:2]	PSDRAM[2:1]	—	—	I/O	M4, P5	J2, P3
SD_CKE	PSDRAM[0]	—	—	O	L3	J1
SD_VREF	—	—	—	I	A15, T2	A13, P2
External Interrupts Port						
\overline{IRQ} [7:5]	PIRQ[7:5]	—	—	I	G13, H16, H15	F14, G13, G14
\overline{IRQ} [4]	PIRQ[4]	$\overline{DREQ2}$	—	I	H14	H11
\overline{IRQ} [3:2]	PIRQ[3:2]	\overline{DREQ} [3:2]	—	I	J14, J13	H14, H12

Table 2. MCF5274 and MCF5275 Signal Information and Muxing (continued)

Signal Name	GPIO	Alternate1	Alternate2	Dir. ¹	MCF5274 MCF5275 256 MAPBGA	MCF5274L MCF5275L 196 MAPBGA
$\overline{\text{IRQ1}}$	PIRQ[1]	—	—	I	K13	J13
FEC0						
FEC0_MDIO	PFECI2C[5]	I2C_SDA	U2RXD	I/O	A7	A3
FEC0_MDC	PFECI2C[4]	I2C_SCL	U2TXD	O	B7	C5
FEC0_TXCLK	PFEC0H[7]	—	—	I	C3	C1
FEC0_TXEN	PFEC0H[6]	—	—	O	D4	C3
FEC0_TXD[0]	PFEC0H[5]	—	—	O	G4	D2
FEC0_COL	PFEC0H[4]	—	—	I	A6	B4
FEC0_RXCLK	PFEC0H[3]	—	—	I	B6	B3
FEC0_RXDV	PFEC0H[2]	—	—	I	B5	C4
FEC0_RXD[0]	PFEC0H[1]	—	—	I	C6	D5
FEC0_CRS	PFEC0H[0]	—	—	I	C7	A2
FEC0_TXD[3:1]	PFEC0L[7:5]	—	—	O	E3, F3, F4	D1, E3, D3
FEC0_TXER	PFEC0L[4]	—	—	O	D3	C2
FEC0_RXD[3:1]	PFEC0L[3:1]	—	—	I	D5, C5, D6	D4, B1, B2
FEC0_RXER	PFEC0L[0]	—	—	I	C4	E4
FEC1						
FEC1_MDIO	PFECI2C[3]	—	—	I/O	G1	—
FEC1_MDC	PFECI2C[2]	—	—	O	G2	—
FEC1_TXCLK	PFEC1H[7]	—	—	I	C1	—
FEC1_TXEN	PFEC1H[6]	—	—	O	D2	—
FEC1_TXD[0]	PFEC1H[5]	—	—	O	F1	—
FEC1_COL	PFEC1H[4]	—	—	I	A5	—
FEC1_RXCLK	PFEC1H[3]	—	—	I	B4	—
FEC1_RXDV	PFEC1H[2]	—	—	I	A3	—
FEC1_RXD[0]	PFEC1H[1]	—	—	I	B3	—
FEC1_CRS	PFEC1H[0]	—	—	I	A4	—
FEC1_TXD[3:1]	PFEC1L[7:5]	—	—	O	E1, E2, F2	—
FEC1_TXER	PFEC1L[4]	—	—	O	D1	—
FEC1_RXD[3:1]	PFEC1L[3:1]	—	—	I	B1, B2, A2	—
FEC1_RXER	PFEC1L[0]	—	—	I	C2	—

Table 2. MCF5274 and MCF5275 Signal Information and Muxing (continued)

Signal Name	GPIO	Alternate1	Alternate2	Dir. ¹	MCF5274 MCF5275 256 MAPBGA	MCF5274L MCF5275L 196 MAPBGA
I²C						
I2C_SDA	PFECI2C[1]	U2RXD	—	I/O	B10	B7
I2C_SCL	PFECI2C[0]	U2TXD	—	I/O	C10	A7
DMA						
DACK[3:0] and $\overline{\text{DREQ}}[3:0]$ do not have a dedicated bond pads. Please refer to the following pins for muxing: PCS3/PWM3 for DACK3, PCS2/PWM2 for DACK2, TSIZ1 for DACK1, TSIZ0 for DACK0, $\overline{\text{IRQ3}}$ for $\overline{\text{DREQ3}}$, $\overline{\text{IRQ2}}$ and $\overline{\text{TA}}$ for DREQ2, TEA for DREQ1, and $\overline{\text{TIP}}$ for DREQ0.					—	—
QSPI						
QSPI_CS[3:2]	PQSPI[6:5]	PWM[3:2]	DACK[3:2]	O	R13, N12	P10, N9
QSPI_CS1	PQSPI[4]	—	—	O	T14	N10
QSPI_CS0	PQSPI[3]	—	—	O	P12	M9
QSPI_CLK	PQSPI[2]	I2C_SCL	—	O	T15	L11
QSPI_DIN	PQSPI[1]	I2C_SDA	—	I	T13	M10
QSPI_DOUT	PQSPI[0]	—	—	O	R12	L10
UARTs						
U2RXD	PUARTH[3]	—	—	I	T9	—
U2TXD	PUARTH[2]	—	—	O	R9	—
$\overline{\text{U2CTS}}$	PUARTH[1]	PWM1	—	I	P9	—
$\overline{\text{U2RTS}}$	PUARTH[0]	PWM0	—	O	R8	—
U1RXD	PUARTL[7]	—	—	I	A9	A6
U1TXD	PUARTL[6]	—	—	O	B9	D7
$\overline{\text{U1CTS}}$	PUARTL[5]	—	—	I	C9	C7
$\overline{\text{U1RTS}}$	PUARTL[4]	—	—	O	D9	B6
U0RXD	PUARTL[3]	—	—	I	A8	A4
U0TXD	PUARTL[2]	—	—	O	B8	A5
$\overline{\text{U0CTS}}$	PUARTL[1]	—	—	I	C8	C6
$\overline{\text{U0RTS}}$	PUARTL[0]	—	—	O	D7	B5
USB						
USB_SPEED	PUSBH[0]	—	—	I/O	G14	G11
USB_CLK	PUSBL[7]	—	—	I	G15	F12

Table 2. MCF5274 and MCF5275 Signal Information and Muxing (continued)

Signal Name	GPIO	Alternate1	Alternate2	Dir. ¹	MCF5274 MCF5275 256 MAPBGA	MCF5274L MCF5275L 196 MAPBGA
USB_RN	PUSBL[6]	—	—	I	J16	H13
USB_RP	PUSBL[5]	—	—	I	J15	J11
USB_RXD	PUSBL[4]	—	—	I	L15	L14
USB_SUSP	PUSBL[3]	—	—	O	M13	N13
USB_TN	PUSBL[2]	—	—	O	K14	J14
USB_TP	PUSBL[1]	—	—	O	K15	J12
USB_TXEN	PUSBL[0]	—	—	O	L14	K13
Timers (and PWMs)						
DT3IN	PTIMERH[3]	DT3OUT	$\overline{U2RTS}$	I	J4	G2
DT3OUT	PTIMERH[2]	PWM3	$\overline{U2CTS}$	O	K3	G1
DT2IN	PTIMERH[1]	DT2OUT	—	I	J2	F3
DT2OUT	PTIMERH[0]	PWM2	—	O	J3	F4
DT1IN	PTIMERL[3]	DT1OUT	—	I	H1	F1
DT1OUT	PTIMERL[2]	PWM1	—	O	H2	F2
DT0IN	PTIMERL[1]	DT0OUT	—	I	H3	E1
DT0OUT	PTIMERL[0]	PWM0	—	O	G3	E2
BDM/JTAG²						
DSCLK	—	\overline{TRST}	—	I	P14	P13
PSTCLK	—	TCLK	—	O	P16	P12
\overline{BKPT}	—	TMS	—	I	R15	N12
DSI	—	TDI	—	I	R16	M12
DSO	—	TDO	—	O	P15	K11
JTAG_EN	—	—	—	I	R14	P11
DDATA[3:0]	—	—	—	O	P10, N10, P11, N11	M7, N7, P8, L9
PST[3:0]	—	—	—	O	T10, R10, T11, R11	P7, L8, M8, N8
Test						
TEST	—	—	—	I	N9	N6
PLL_TEST	—	—	—	I	M14	—
Power Supplies						
VDDPLL	—	—	—	I	M15	M13

Table 2. MCF5274 and MCF5275 Signal Information and Muxing (continued)

Signal Name	GPIO	Alternate1	Alternate2	Dir. ¹	MCF5274 MCF5275 256 MAPBGA	MCF5274L MCF5275L 196 MAPBGA
VSSPLL	—	—	—	I	K16	L13
VSS	—	—	—	I	A1, A10, A16, E5, E12, F6, F11, G7:10, H7:10, J1, J7:10, K7:10, L6, L11, M5, N16, R7, T1, T16	F7, F8, G6:9, H6:9, J7, J8
OVDD	—	—	—	I	E6:8, F5, F7, F8, G5, G6, H5, H6, J11, J12, K11, K12, L9, L10, L12, M9:11	E5:7, F5, F6, H10, J9, J10, K8:10
VDD	—	—	—	I	D8, H13, K4, N8	D6, G5, G12, L7
SD_VDD	—	—	—	I	E9:11, F9, F10, F12, G11, G12, H11, H12, J5, J6, K5, K6, L5, L7, L8, M6, M7, M8	E8:10, F9, F10, G10, H5, J5, J6, K5:7

¹ Refers to pin's primary function. All pins which are configurable for GPIO have a pullup enabled in GPIO mode with the exception of PBUSCTL[7], PBUSCTL[4:0], PADDR, PBS, PSDRAM.

² If JTAG_EN is asserted, these pins default to Alternate 1 (JTAG) functionality. The GPIO module is not responsible for assigning these pins.

5 Design Recommendations

5.1 Layout

- Use a 4-layer printed circuit board with the VDD and GND pins connected directly to the power and ground planes for the MCF5275.
- See application note AN1259 System Design and Layout Techniques for Noise Reduction in MCU-Based Systems.
- Match the PCB layout trace width and routing to match trace length to operating frequency and board impedance. Add termination (series or therein) to the traces to dampen reflections. Increase the PCB impedance (if possible) keeping the trace lengths balanced and short. Then do cross-talk analysis to separate traces with significant parallelism or are otherwise "noisy". Use 6 mils trace and separation. Clocks get extra separation and more precise balancing.

5.2 Power Supply

- 33 μ F, 0.1 μ F, and 0.01 μ F across each power supply

5.2.1 Supply Voltage Sequencing and Separation Cautions

Figure 2 shows situations in sequencing the I/O V_{DD} (OV_{DD}), SDRAM V_{DD} (SDV_{DD}), PLL V_{DD} ($PLLV_{DD}$), and Core V_{DD} (V_{DD}).

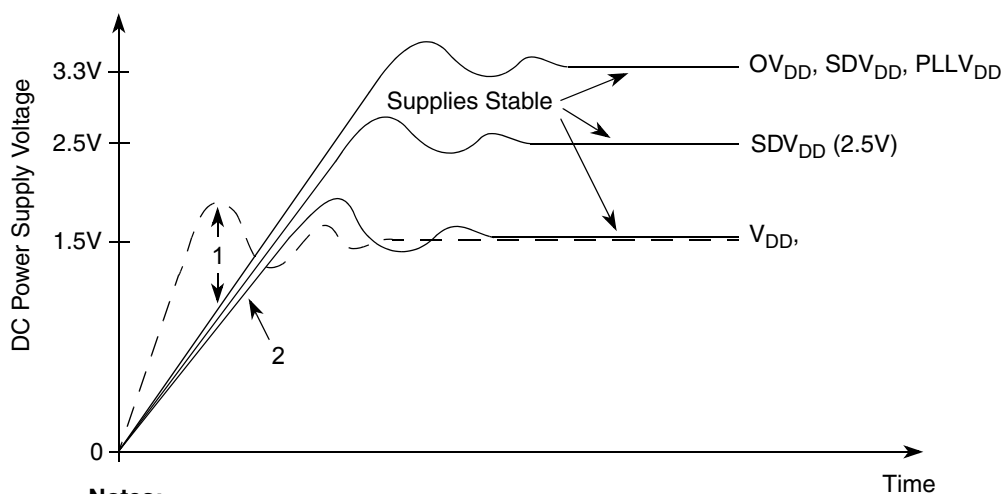

Notes:

1. V_{DD} should not exceed OV_{DD} , SDV_{DD} or $PLLV_{DD}$ by more than 0.4 V at any time, including power-up.
2. Recommended that V_{DD} should track $OV_{DD}/SDV_{DD}/PLLV_{DD}$ up to 0.9 V, then separate for completion of ramps.
3. Input voltage must not be greater than the supply voltage (OV_{DD} , SDV_{DD} , V_{DD} , or $PLLV_{DD}$) by more than 0.5 V at any time, including during power-up.
4. Use 1 ms or slower rise time for all supplies.

Figure 2. Supply Voltage Sequencing and Separation Cautions

The relationship between SDV_{DD} and OV_{DD} is non-critical during power-up and power-down sequences. SDV_{DD} (2.5V or 3.3V) and OV_{DD} are specified relative to V_{DD} .

5.2.1.1 Power Up Sequence

If OV_{DD}/SDV_{DD} are powered up with V_{DD} at 0 V, then the sense circuits in the I/O pads cause all pad output drivers connected to the OV_{DD}/SDV_{DD} to be in a high impedance state. There is no limit on how long after OV_{DD}/SDV_{DD} powers up before V_{DD} must be powered up. V_{DD} should not lead the OV_{DD} , SDV_{DD} , or $PLLV_{DD}$ by more than 0.4 V during power ramp-up or high current will be in the internal ESD protection diodes. The rise times on the power supplies should be slower than 1 μ s to avoid turning on the internal ESD protection clamp diodes.

The recommended power up sequence is as follows:

1. Use 1 μ s or slower rise time for all supplies.
2. $V_{DD}/PLLV_{DD}$ and OV_{DD}/SDV_{DD} should track up to 0.9 V, then separate for the completion of ramps with OV_{DD}/SDV_{DD} going to the higher external voltages. One way to accomplish this is to use a low drop-out voltage regulator.

5.2.1.2 Power Down Sequence

If V_{DD} is powered down first, then sense circuits in the I/O pads cause all output drivers to be in a high impedance state. There is no limit on how long after V_{DD} powers down before OV_{DD} , SDV_{DD} , or $PLL_{V_{DD}}$ must power down. V_{DD} should not lag OV_{DD} , SDV_{DD} , or $PLL_{V_{DD}}$ going low by more than 0.4 V during power down or undesired high current will be in the ESD protection diodes. There are no requirements for the fall times of the power supplies.

The recommended power down sequence is as follows:

1. Drop V_{DD} to 0 V.
2. Drop $OV_{DD}/SDV_{DD}/PLL_{V_{DD}}$ supplies.

5.3 Decoupling

- Place the decoupling capacitors as close to the pins as possible, but they can be outside the footprint of the package.
- 0.1 μ F and 0.01 μ F at each supply input

5.4 Buffering

- Use bus buffers on all data/address lines for all off-board accesses and for all on-board accesses when excessive loading is expected. See electricals.

5.5 Pull-up Recommendations

- Use external pull-up resistors on unused inputs. See pin table.

5.6 Clocking Recommendations

- Use a multi-layer board with a separate ground plane.
- Place the crystal and all other associated components as close to the EXTAL and XTAL (oscillator pins) as possible.
- Do not run a high frequency trace around crystal circuit.
- Ensure that the ground for the bypass capacitors is connected to a solid ground trace.
- Tie the ground trace to the ground pin nearest EXTAL and XTAL. This prevents large loop currents in the vicinity of the crystal.
- Tie the ground pin to the most solid ground in the system.
- Do not connect the trace that connects the oscillator and the ground plane to any other circuit element. This tends to make the oscillator unstable.
- Tie XTAL to ground when an external oscillator is clocking the device.

5.7 Interface Recommendations

5.7.1 DDR SDRAM Controller

5.7.1.1 SDRAM Controller Signals in Synchronous Mode

Table 3 shows the behavior of SDRAM signals in synchronous mode.

Table 3. Synchronous DRAM Signal Connections

Signal	Description
SD_SRAS	Synchronous row address strobe. Indicates a valid SDRAM row address is present and can be latched by the SDRAM. SD_SRAS should be connected to the corresponding SDRAM SD_SRAS. Do not confuse SD_SRAS with the DRAM controller's SDRAM_CS[1:0], which should not be interfaced to the SDRAM SD_SRAS signals.
SD_SCAS	Synchronous column address strobe. Indicates a valid column address is present and can be latched by the SDRAM. SD_SCAS should be connected to the corresponding signal labeled SD_SCAS on the SDRAM.
SD_WE	DRAM read/write. Asserted for write operations and negated for read operations.
SD_CS[1:0]	Row address strobe. Select each memory block of SDRAMs connected to the MCF5275. One SDRAM_CS signal selects one SDRAM block and connects to the corresponding CS signals.
SD_CKE	Synchronous DRAM clock enable. Connected directly to the CKE (clock enable) signal of SDRAMs. Enables and disables the clock internal to SDRAM. When CKE is low, memory can enter a power-down mode where operations are suspended or they can enter self-refresh mode. SD_CKE functionality is controlled by DCR[COC]. For designs using external multiplexing, setting COC allows SD_CKE to provide command-bit functionality.
BS[3:2]	Column address strobe. For synchronous operation, BS[3:2] function as byte enables to the SDRAMs. They connect to the DQM signals (or mask qualifiers) of the SDRAMs.
DDR_CLKOUT	Bus clock output. Connects to the CLK input of SDRAMs.

5.7.1.2 Address Multiplexing

See the SDRAM controller module chapter in the *MCF5275 Reference Manual* for details on address multiplexing.

5.7.2 Ethernet PHY Transceiver Connection

The FEC supports an MII interface for 10/100 Mbps Ethernet and a seven-wire serial interface for 10 Mbps Ethernet. The interface mode is selected by R_CNTRL[MII_MODE]. In MII mode, the 802.3 standard defines and the FEC module supports 18 signals. These are shown in Table 4.

Table 4. MII Mode

Signal Description	MCF5275 Pin
Transmit clock	FEC _n _TXCLK
Transmit enable	FEC _n _TXEN
Transmit data	FEC _n _TXD[3:0]
Transmit error	FEC _n _TXER

Table 4. MII Mode (continued)

Signal Description	MCF5275 Pin
Collision	FEC _n _COL
Carrier sense	FEC _n _CRS
Receive clock	FEC _n _RXCLK
Receive enable	FEC _n _RXDV
Receive data	FEC _n _RXD[3:0]
Receive error	FEC _n _RXER
Management channel clock	FEC _n _MDC
Management channel serial data	FEC _n _MDIO

The serial mode interface operates in what is generally referred to as AMD mode. The MCF5275 configuration for seven-wire serial mode connections to the external transceiver are shown in [Table 5](#).

Table 5. Seven-Wire Mode Configuration

Signal Description	MCF5275 Pin
Transmit clock	FEC _n _TXCLK
Transmit enable	FEC _n _TXEN
Transmit data	FEC _n _TXD[0]
Collision	FEC _n _COL
Receive clock	FEC _n _RXCLK
Receive enable	FEC _n _RXDV
Receive data	FEC _n _RXD[0]
Unused, configure as PB14	FEC _n _RXER
Unused input, tie to ground	FEC _n _CRS
Unused, configure as PB[13:11]	FEC _n _RXD[3:1]
Unused output, ignore	FEC _n _TXER
Unused, configure as PB[10:8]	FEC _n _TXD[3:1]
Unused, configure as PB15	FEC _n _MDC
Input after reset, connect to ground	FEC _n _MDIO

Refer to the M5275EVB evaluation board user's manual for an example of how to connect an external PHY. Schematics for this board are accessible at the MCF5275 site by navigating to: <http://www.freescale.com/coldfire>.

5.7.3 BDM

Use the BDM interface as shown in the M5275EVB evaluation board user's manual. The schematics for this board are accessible at the MCF5275 site by navigating to: <http://www.freescale.com/coldfire>.

6 Mechanicals/Pinouts

6.1 256 MAPBGA Pinout

Figure 3 is a consolidated MCF5274/75 pinout for the 256 MAPBGA package. Table 2 lists the signals by group and shows which signals are muxed and bonded on each of the device packages.

	1	2	3	4	5	6	7	8	9	10	11	12	13	14	15	16	
A	VSS	FEC1_RXD1	FEC1_RXDV	FEC1_CRS	FEC1_COL	FEC0_COL	FEC0_MDIO	U0RXD	U1RXD	VSS	A23	A20	A17	A14	SD_VREF	VSS	A
B	FEC1_RXD3	FEC1_RXD2	FEC1_RXD0	FEC1_RXCLK	FEC0_RXDV	FEC0_RXCLK	FEC0_MDC	U0TXD	U1TXD	I2C_SDA	A22	A19	A16	A13	A11	A9	B
C	FEC1_TXCLK	FEC1_RXER	FEC0_TXCLK	FEC0_RXER	FEC0_RXD2	FEC0_RXD0	FEC0_CRS	$\overline{U0CTS}$	$\overline{U1CTS}$	I2C_SCL	A21	A18	A15	A12	A10	A8	C
D	FEC1_TXER	FEC1_TXEN	FEC0_TXER	FEC0_TXEN	FEC0_RXD3	FEC0_RXD1	$\overline{U0RTS}$	VDD	$\overline{U1RTS}$	$\overline{CS7}$	$\overline{CS6}$	$\overline{CS5}$	$\overline{CS4}$	A7	A6	TSIZ1	D
E	FEC1_TXD3	FEC1_TXD2	FEC0_TXD3	NC	VSS	OVDD	OVDD	OVDD	SD_VDD	SD_VDD	SD_VDD	VSS	$\overline{CS3}$	A5	A4	A3	E
F	FEC1_TXD0	FEC1_TXD1	FEC0_TXD2	FEC0_TXD1	OVDD	VSS	OVDD	OVDD	SD_VDD	SD_VDD	VSS	SD_VDD	$\overline{CS2}$	A2	A1	A0	F
G	FEC1_MDIO	FEC1_MDC	DT0OUT	FEC0_TXD0	OVDD	OVDD	VSS	VSS	VSS	VSS	SD_VDD	SD_VDD	$\overline{IRQ7}$	USB_SPEED	USB_CLK	TSIZ0	G
H	DT1IN	DT1OUT	DT0IN	NC	OVDD	OVDD	VSS	VSS	VSS	VSS	SD_VDD	SD_VDD	VDD	$\overline{IRQ4}$	$\overline{IRQ5}$	$\overline{IRQ6}$	H
J	VSS	DT2IN	DT2OUT	DT3IN	SD_VDD	SD_VDD	VSS	VSS	VSS	VSS	OVDD	OVDD	$\overline{IRQ2}$	$\overline{IRQ3}$	USB_RP	USB_RN	J
K	\overline{OE}	$\overline{SD_WE}$	DT3OUT	VDD	SD_VDD	SD_VDD	VSS	VSS	VSS	VSS	OVDD	OVDD	$\overline{IRQ1}$	USB_TN	USB_TP	VSSPLL	K
L	$\overline{SD_SCAS}$	$\overline{SD_SRAS}$	SD_CKE	\overline{TS}	SD_VDD	VSS	SD_VDD	SD_VDD	OVDD	OVDD	VSS	OVDD	\overline{TA}	USB_TXEN	USB_RXD	EXTAL	L
M	D31	$\overline{SD_CS1}$	$\overline{BS3}$	SD_DQS3	VSS	SD_VDD	SD_VDD	SD_VDD	OVDD	OVDD	OVDD	NC	USB_SUSP	PLL_TEST	VDDPLL	XTAL	M
N	D30	D29	D28	D20	D16	SD_A10	$\overline{CS1}$	VDD	TEST	DDATA2	DDATA0	QSPL_CS2	CLK_MOD1	\overline{RSTOUT}	\overline{RESET}	VSS	N
P	D27	D26	D23	D19	SD_DQS2	\overline{TIP}	R/W	\overline{RCON}	$\overline{U2CTS}$	DDATA3	DDATA1	QSPL_CS0	CLK_MOD0	$\overline{TRST}/$ DSCLK	TDO/ DSO	TCLK/ PSTCLK	P
R	D25	D24	D22	D18	$\overline{BS2}$	$\overline{CS0}$	VSS	$\overline{U2RTS}$	U2TXD	PST2	PST0	QSPL_DOUT	QSPL_CS3	JTAG_EN	TMS/ BKPT	TDI/DSI	R
T	VSS	SD_VREF	D21	D17	$\overline{SD_CS0}$	$\overline{DDR_CLK}$ OUT	DDR_CLK OUT	\overline{TEA}	U2RXD	PST3	PST1	CLKOUT	QSPL_DIN	QSPL_CS1	QSPL_CLK	VSS	T
	1	2	3	4	5	6	7	8	9	10	11	12	13	14	15	16	

Figure 3. MCF5274 and MCF5275 Pinout (256 MAPBGA)

6.2 Package Dimensions - 256 MAPBGA

Figure 6 shows MCF5275 256 MAPBGA package dimensions.

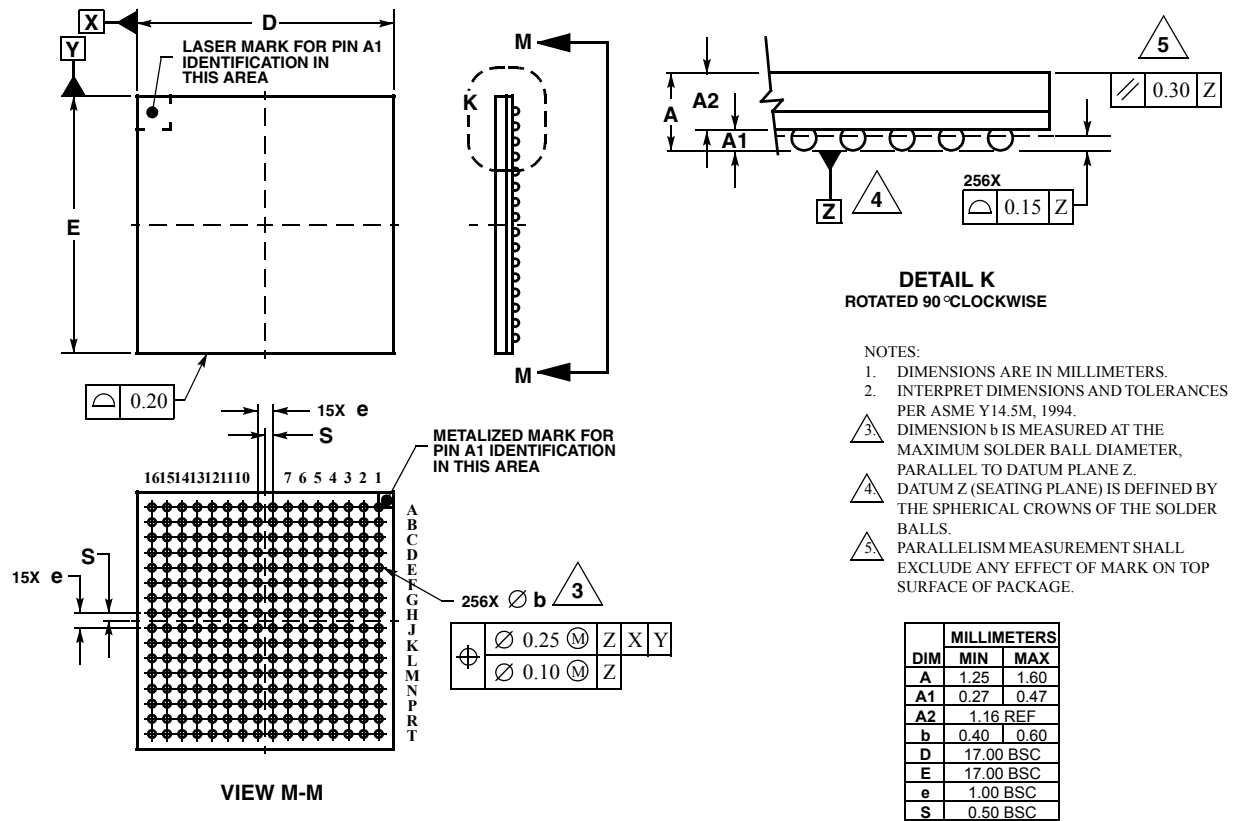

Figure 4. 256 MAPBGA Package Dimensions

6.3 196 MAPBGA Pinout

Figure 5 is a consolidated MCF5274L/75L pinout for the 196 MAPBGA package. Table 2 lists the signals by group and shows which signals are muxed and bonded on each of the device packages.

	1	2	3	4	5	6	7	8	9	10	11	12	13	14	
A	NC	FEC0_CRS	FEC0_MDIO	U0RXD	U0TXD	U1RXD	I2C_SCL	A23	$\overline{CS6}$	$\overline{CS5}$	A15	A12	SD_VREF	NC	A
B	FEC0_RXD2	FEC0_RXD1	FEC0_RXCLK	FEC0_COL	$\overline{U0RTS}$	$\overline{U1RTS}$	I2C_SDA	A22	A20	A16	A13	$\overline{CS3}$	A9	TSIZ1	B
C	FEC0_TXCLK	FEC0_TXER	FEC0_TXEN	FEC0_RXDV	FEC0_MDC	$\overline{U0CTS}$	$\overline{U1CTS}$	A21	A18	A17	A14	A10	A8	$\overline{CS2}$	C
D	FEC0_TXD3	FEC0_TXD0	FEC0_TXD1	FEC0_RXD3	FEC0_RXD0	VDD	U1TXD	$\overline{CS7}$	A19	$\overline{CS4}$	A11	A7	A5	A2	D
E	DT0IN	DT0OUT	FEC0_TXD2	FEC0_RXER	OVDD	OVDD	OVDD	SD_VDD2	SD_VDD2	SD_VDD2	A6	A4	A1	TSIZ0	E
F	DT1IN	DT1OUT	DT2IN	DT2OUT	OVDD	OVDD	VSS	VSS	SD_VDD2	SD_VDD2	A3	USB_CLK	A0	$\overline{IRQ7}$	F
G	DT3OUT	DT3IN	$\overline{SD_CAS}$	$\overline{SD_WE}$	VDD	VSS	VSS	VSS	VSS	SD_VDD2	USB_SPEED	VDD	$\overline{IRQ6}$	$\overline{IRQ5}$	G
H	$\overline{SD_SRAS}$	\overline{TS}	$\overline{SD_CS1}$	\overline{OE}	SD_VDD1	VSS	VSS	VSS	VSS	OVDD	$\overline{IRQ4}$	$\overline{IRQ2}$	USB_RN	$\overline{IRQ3}$	H
J	SD_CKE	SD_DQS3	D31	D22	SD_VDD1	SD_VDD1	VSS	VSS	OVDD	OVDD	USB_RP	USB_TP	$\overline{IRQ1}$	USB_TN	J
K	$\overline{BS3}$	D29	D28	D23	SD_VDD1	SD_VDD1	SD_VDD1	OVDD	OVDD	OVDD	TDO/DSO	\overline{RESET}	USB_TXEN	\overline{TA}	K
L	D30	D26	D25	D24	$\overline{BS2}$	R \overline{W}	VDD	PST2	DDATA0	QSPI_DOUT	QSPI_CLK	\overline{RSTOUT}	VSSPLL	USB_RXD	L
M	D27	D21	D18	D17	$\overline{SD_CS0}$	\overline{RCON}	DDATA3	PST1	QSPI_CS0	QSPI_DIN	CLKMOD1	TDI/DSI	VDDPLL	EXTAL	M
N	D20	D19	D16	SD_A10	$\overline{CS0}$	TEST	DDATA2	PST0	QSPI_CS2	QSPI_CS1	CLKMOD0	TMS/BKPT	USB_SUSP	XTAL	N
P	NC	SD_VREF	SD_DQS2	$\overline{CS1}$	$\overline{DDR_CLK}$ OUT	DDR_CLK OUT	PST3	DDATA1	CLKOUT	QSPI_CS3	JTAG_EN	TCLK/PST CLK	$\overline{TRST/DSC}$ LK	NC	P
	1	2	3	4	5	6	7	8	9	10	11	12	13	14	

Figure 5. MCF5274L and MCF5275L Pinout (196 MAPBGA)

6.4 Package Dimensions - 196 MAPBGA

Figure 6 shows MCF5275 196 MAPBGA package dimensions.

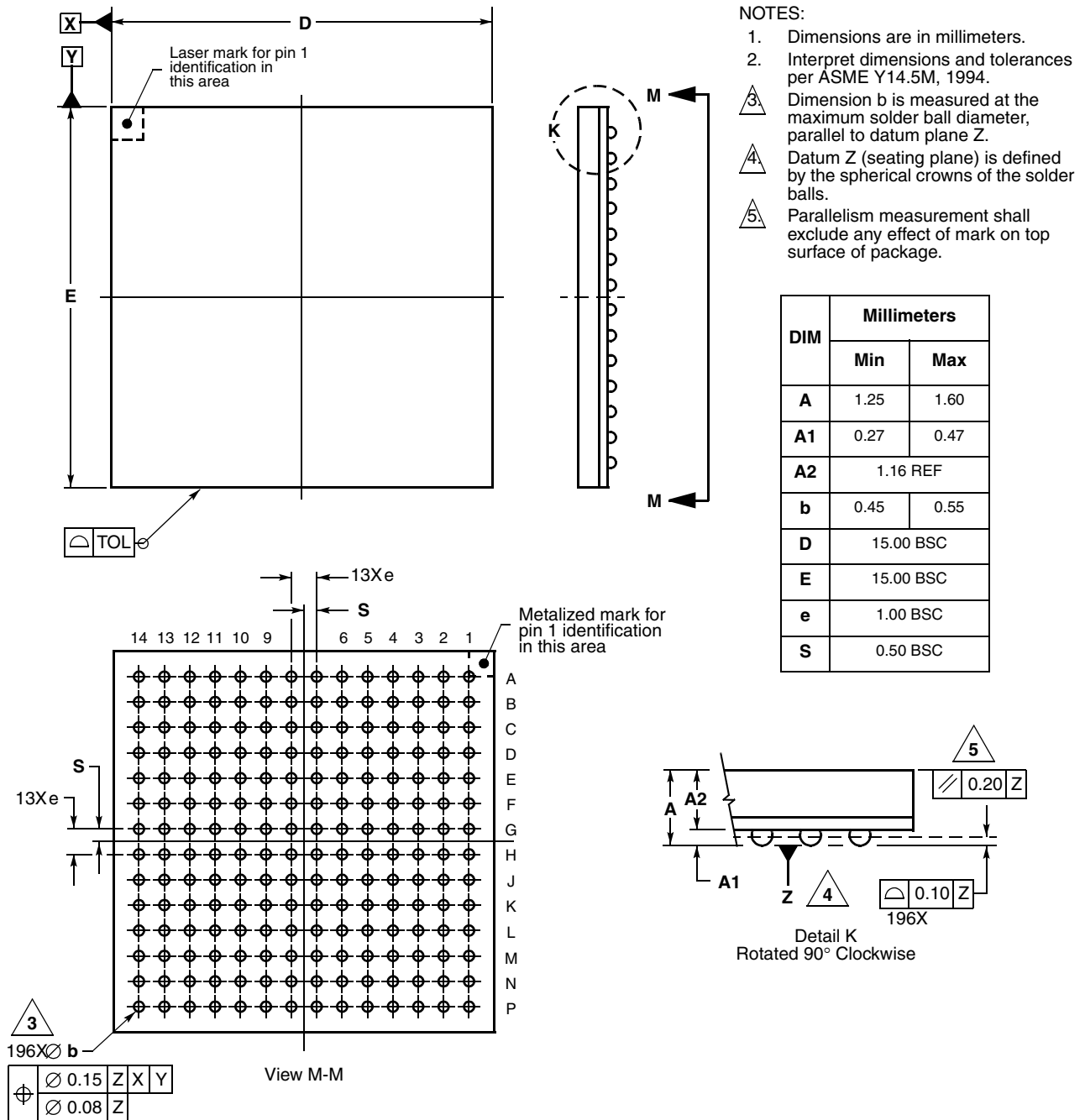

Figure 6. 196 MAPBGA Package Dimensions

7 Ordering Information

Table 6. Orderable Part Numbers

Freescal Part Number	Description	Package	Speed	Temperature
MCF5274LVM166	MCF5274L RISC Microprocessor	196 MAPBGA	166 MHz	0° to +70° C
MCF5274LCVM166				-40° to +85° C
MCF5274VM166	MCF5274 RISC Microprocessor	256 MAPBGA	166 MHz	0° to +70° C
MCF5274CVM166				-40° to +85° C
MCF5275LCVM166	MCF5275L RISC Microprocessor	196 MAPBGA	166 MHz	-40° to +85° C
MCF5275CVM166	MCF5275 RISC Microprocessor	256 MAPBGA	166 MHz	-40° to +85° C

8 Electrical Characteristics

This appendix contains electrical specification tables and reference timing diagrams for the MCF5275 microcontroller unit. This section contains detailed information on power considerations, DC/AC electrical characteristics, and AC timing specifications of MCF5275.

NOTE

The parameters specified in this appendix supersede any values found in the module specifications.

8.1 Maximum Ratings

 Table 7. Absolute Maximum Ratings^{1, 2}

Rating	Symbol	Value	Unit
Core Supply Voltage	V_{DD}	- 0.5 to +2.0	V
I/O Pad Supply Voltage (3.3V)	OV_{DD}	- 0.3 to +4.0	V
Memory Interface SSTL 2.5V Pad Supply Voltage	SDV_{DD}	- 0.3 to + 2.8	V
Memory Interface SSTL 3.3V Pad Supply Voltage	SDV_{DD}	- 0.3 to +4.0	V
PLL Supply Voltage	V_{DDPLL}	- 0.3 to +4.0	V
Digital Input Voltage ³	V_{IN}	- 0.3 to + 4.0	V
EXTAL pin voltage	V_{EXTAL}	0 to 3.3	V
XTAL pin voltage	V_{XTAL}	0 to 3.3	V
Instantaneous Maximum Current Single pin limit (applies to all pins) ^{4, 5}	I_D	25	mA
Operating Temperature Range (Packaged)	T_A ($T_L - T_H$)	- 40 to 85	°C
Storage Temperature Range	T_{stg}	- 65 to 150	°C

¹ Functional operating conditions are given in DC Electrical Specifications. Absolute Maximum Ratings are stress ratings only, and functional operation at the maxima is not guaranteed. Stress beyond those listed may affect device reliability or cause permanent damage to the device.

- 2 This device contains circuitry protecting against damage due to high static voltage or electrical fields; however, it is advised that normal precautions be taken to avoid application of any voltages higher than maximum-rated voltages to this high-impedance circuit. Reliability of operation is enhanced if unused inputs are tied to an appropriate logic voltage level (e.g., V_{SS} or $O V_{DD}$).
- 3 Input must be current limited to the value specified. To determine the value of the required current-limiting resistor, calculate resistance values for positive and negative clamp voltages, then use the larger of the two values.
- 4 All functional non-supply pins are internally clamped to V_{SS} and $O V_{DD}$.
- 5 Power supply must maintain regulation within operating $O V_{DD}$ range during instantaneous and operating maximum current conditions. If positive injection current ($V_{in} > O V_{DD}$) is greater than I_{DD} , the injection current may flow out of $O V_{DD}$ and could result in external power supply going out of regulation. Ensure the external $O V_{DD}$ load shunts current greater than maximum injection current. This is the greatest risk when the MCU is not consuming power (ex; no clock). Power supply must maintain regulation within operating V_{DD} range during instantaneous and operating maximum current conditions.

8.2 Thermal Characteristics

Table 8 lists thermal resistance values

Table 8. Thermal characteristics

Characteristic		Symbol	256MBGA	196MBGA	Unit
Junction to ambient, natural convection	Four layer board (2s2p)	θ_{JMA}	26 ^{1,2}	32 ^{1,2}	°C/W
Junction to ambient (@200 ft/min)	Four layer board (2s2p)	θ_{JMA}	23 ^{1,2}	29 ^{1,2}	°C/W
Junction to board		θ_{JB}	15 ³	20 ³	°C/W
Junction to case		θ_{JC}	10 ⁴	10 ⁴	°C/W
Junction to top of package	Natural convection	Ψ_{jt}	2 ^{1,5}	2 ^{1,5}	°C/W
Maximum operating junction temperature		T_j	105	105	°C

¹ θ_{JMA} and Ψ_{jt} parameters are simulated in conformance with EIA/JESD Standard 51-2 for natural convection. Freescale recommends the use of θ_{JMA} and power dissipation specifications in the system design to prevent device junction temperatures from exceeding the rated specification. System designers should be aware that device junction temperatures can be significantly influenced by board layout and surrounding devices. Conformance to the device junction temperature specification can be verified by physical measurement in the customer's system using the Ψ_{jt} parameter, the device power dissipation, and the method described in EIA/JESD Standard 51-2.

² Per JEDEC JESD51-6 with the board horizontal.

³ Thermal resistance between the die and the printed circuit board in conformance with JEDEC JESD51-8. Board temperature is measured on the top surface of the board near the package.

⁴ Thermal resistance between the die and the case top surface as measured by the cold plate method (MIL SPEC-883 Method 1012.1).

⁵ Thermal characterization parameter indicating the temperature difference between package top and the junction temperature per JEDEC JESD51-2. When Greek letters are not available, the thermal characterization parameter is written in conformance with Psi-JT.

The average chip-junction temperature (T_j) in °C can be obtained from:

$$T_j = T_A + (P_D \times \theta_{JMA}) \quad (1)$$

Where:

T_A = Ambient Temperature, °C

θ_{JMA} = Package Thermal Resistance, Junction-to-Ambient, °C/W

P_D = $P_{INT} + P_{IO}$

Electrical Characteristics

P_{INT} = $I_{DD} \times V_{DD}$, Watts - Chip Internal Power

$P_{I/O}$ = Power Dissipation on Input and Output Pins — User Determined

For most applications $P_{I/O} < P_{INT}$ and can be ignored. An approximate relationship between P_D and T_J (if $P_{I/O}$ is neglected) is:

$$P_D = K \div (T_J + 273^\circ C) \quad (2)$$

Solving equations 1 and 2 for K gives:

$$K = P_D \times (T_A + 273^\circ C) + \Theta_{JMA} \times P_D^2 \quad (3)$$

where K is a constant pertaining to the particular part. K can be determined from equation (3) by measuring P_D (at equilibrium) for a known T_A . Using this value of K, the values of P_D and T_J can be obtained by solving equations (1) and (2) iteratively for any value of T_A .

8.3 ESD Protection

Table 9. ESD Protection Characteristics^{1, 2}

Characteristics	Symbol	Value	Units
ESD Target for Human Body Model	HBM	2000	V
ESD Target for Machine Model	MM	200	V
HBM Circuit Description	R_{series}	1500	Ω
	C	100	pF
MM Circuit Description	R_{series}	0	Ω
	C	200	pF
Number of pulses per pin (HBM)	—	1	—
	—	1	—
Number of pulses per pin (MM)	—	3	—
	—	3	—
Interval of Pulses	—	1	sec

¹ All ESD testing is in conformity with CDF-AEC-Q100 Stress Test Qualification for Automotive Grade Integrated Circuits.

² A device is defined as a failure if after exposure to ESD pulses the device no longer meets the device specification requirements. Complete DC parametric and functional testing is performed per applicable device specification at room temperature followed by hot temperature, unless specified otherwise in the device specification.

8.4 DC Electrical Specifications

Table 10. DC Electrical Specifications¹

Characteristic	Symbol	Min	Max	Unit
Core Supply Voltage	V_{DD}	1.4	1.6	V
I/O Pad Supply Voltage	OV_{DD}	3.0	3.6	V
PLL Supply Voltage	V_{DDPLL}	3.0	3.6	V
SSTL I/O Pad Supply Voltage	SDV_{DD}	2.3	2.7	V
SSTL I/O Pad Supply Voltage	SDV_{DD}	3.0	3.6	V
SSTL Memory pads reference voltage (SD $V_{DD} = 2.5V$)	V_{REF}	0.5 SD V_{DD}	— ²	V
SSTL Memory pads reference voltage (SD $V_{DD} = 3.3V$)	V_{REF}	0.45 SD V_{DD}	— ²	V
Input High Voltage 3.3V I/O Pads	V_{IH}	$0.7 \times OV_{DD}$	$OV_{DD} + 0.3$	V
Input Low Voltage 3.3V I/O Pads	V_{IL}	$V_{SS} - 0.3$	$0.35 \times OV_{DD}$	V
Output High Voltage 3.3V I/O Pads $I_{OH} = -2.0 \text{ mA}$	V_{OH}	$OV_{DD} - 0.5$	—	V
Output Low Voltage 3.3V I/O Pads $I_{OL} = 2.0 \text{ mA}$	V_{OL}	—	0.5	V
Input Hysteresis 3.3V I/O Pads	V_{HYS}	$0.06 \times V_{DD}$	—	mV
Input High Voltage SSTL 3.3V/2.5V ³	V_{IH}	$V_{REF} + 0.3$	$SDV_{DD} + 0.3$	V
Input Low Voltage SSTL 3.3V/2.5V ³	V_{IL}	$V_{SS} - 0.3$	$V_{REF} - 0.3$	V
Output High Voltage SSTL 3.3V/2.5V ⁴ $I_{OH} = -5.0 \text{ mA}$	V_{OH}	$SDV_{DD} - 0.25V$	—	V
Output Low Voltage SSTL 3.3V/2.5V ⁴ $I_{OL} = 5.0 \text{ mA}$	V_{OL}	—	0.35	V
Input Leakage Current $V_{in} = V_{DD}$ or V_{SS} , Input-only pins	I_{in}	-1.0	1.0	μA
High Impedance (Off-State) Leakage Current $V_{in} = V_{DD}$ or V_{SS} , All input/output and output pins	I_{OZ}	-1.0	1.0	μA
Weak Internal Pull Up Device Current, tested at V_{IL} Max. ⁵	I_{APU}	-10	-130	μA
Input Capacitance ⁶ All input-only pins All input/output (three-state) pins	C_{in}	— —	7 7	pF

Table 10. DC Electrical Specifications¹ (continued)

Characteristic	Symbol	Min	Max	Unit
Load Capacitance ⁷ Low Drive Strength High Drive Strength	C_L	— —	25 50	pF
Core Operating Supply Current ⁸ Master Mode WAIT DOZE STOP	I_{DD}	— — — —	175 15 10 100	mA mA mA μ A
I/O Pad Operating Supply Current Master Mode Low Power Modes	OI_{DD}	— —	250 250	mA μ A
DC Injection Current ^{3, 9, 10, 11} $V_{NEGCLAMP} = V_{SS} - 0.3$ V, $V_{POSCLAMP} = V_{DD} + 0.3$ Single Pin Limit Total MCU Limit, Includes sum of all stressed pins	I_{IC}	— -1.0 -10	— 1.0 10	mA

- ¹ Refer to Table 11 for additional PLL specifications.
- ² V_{REF} is specified as a nominal value only instead of a range, so no maximum value is listed.
- ³ This specification is guaranteed by design and is not 100% tested.
- ⁴ The actual V_{OH} and V_{OL} values for SSTL pads are dependent on the termination and drive strength used. The specifications numbers assume no parallel termination.
- ⁵ Refer to the MCF5274 signals chapter for pins having weak internal pull-up devices.
- ⁶ This parameter is characterized before qualification rather than 100% tested.
- ⁷ pF load ratings are based on DC loading and are provided as an indication of driver strength. High speed interfaces require transmission line analysis to determine proper drive strength and termination.
- ⁸ Current measured at maximum system clock frequency, all modules active, and default drive strength with matching load.
- ⁹ All functional non-supply pins are internally clamped to V_{SS} and their respective V_{DD} .
- ¹⁰ Input must be current limited to the value specified. To determine the value of the required current-limiting resistor, calculate resistance values for positive and negative clamp voltages, then use the larger of the two values.
- ¹¹ Power supply must maintain regulation within operating V_{DD} range during instantaneous and operating maximum current conditions. If positive injection current ($V_{in} > V_{DD}$) is greater than I_{DD} , the injection current may flow out of V_{DD} and could result in external power supply going out of regulation. Ensure the external V_{DD} load shunts current greater than maximum injection current. This is the greatest risk when the MCU is not consuming power. Examples are: if no system clock is present, or if clock rate is very low which would reduce overall power consumption. Also, at power-up, system clock is not present during the power-up sequence until the PLL has attained lock.

8.5 Oscillator and Phase Lock Loop (PLL/MRFB) Electrical Specifications

 Table 11. PLL Electrical Specifications¹

Characteristic	Symbol	Min	Max	Unit
PLL Reference Frequency Range				MHz
Crystal reference	$f_{ref_crystal}$	8	25	
External reference	f_{ref_ext}	8	25	
1:1 Mode (NOTE: $f_{sys/2} = 2 \times f_{ref_1:1}$)	$f_{ref_1:1}$	24	83	
Core frequency	f_{core}		166	MHz
CLKOUT Frequency ²				
External reference		0	83	MHz
On-Chip PLL Frequency	$f_{sys/2}$	$f_{ref} / 32$	83	MHz
Loss of Reference Frequency ^{3, 5}	f_{LOR}	100	1000	kHz
Self Clocked Mode Frequency ^{4, 5}	f_{SCM}	TBD	TBD	MHz
Crystal Start-up Time ^{5, 6}	t_{cst}	—	10	ms
EXTAL Input High Voltage	V_{IHEXT}			V
Crystal Mode	V_{IHEXT}	TBD	TBD	
All other modes (Dual Controller (1:1), Bypass, External)		TBD	TBD	
EXTAL Input Low Voltage	V_{ILEXT}			V
Crystal Mode	V_{ILEXT}	TBD	TBD	
All other modes (Dual Controller (1:1), Bypass, External)		TBD	TBD	
XTAL Output High Voltage	V_{OH}			V
$I_{OH} = 1.0$ mA		TBD	—	
XTAL Output Low Voltage	V_{OL}			V
$I_{OL} = 1.0$ mA		—	TBD	
XTAL Load Capacitance ⁷		5	30	pF
PLL Lock Time ⁸	t_{ipll}	—	750	μ s
Power-up To Lock Time ^{6, 9}	t_{iplk}			
With Crystal Reference		—	11	ms
Without Crystal Reference ¹⁰		—	750	μ s
1:1 Mode Clock Skew (between CLKOUT and EXTAL) ¹¹	t_{skew}	-1	1	ns
Duty Cycle of reference ⁵	t_{dc}	40	60	% $f_{sys/2}$
Frequency un-LOCK Range	f_{UL}	-3.8	4.1	% $f_{sys/2}$
Frequency LOCK Range	f_{LCK}	-1.7	2.0	% $f_{sys/2}$
CLKOUT Period Jitter, ^{5, 6, 9, 12, 13} Measured at $f_{sys/2}$ Max	C_{jitter}			
Peak-to-peak Jitter (Clock edge to clock edge)		—	5	% $f_{sys/2}$
Long Term Jitter (Averaged over 2 ms interval)		—	.01	
Frequency Modulation Range Limit ^{14, 15}	C_{mod}	0.8	2.2	% $f_{sys/2}$
($f_{sys/2}$ Max must not be exceeded)				
ICO Frequency. $f_{ico} = f_{ref} * 2 * (MFD+2)$ ¹⁶	f_{ico}	48	83	MHz

¹ All values given are initial design targets and subject to change.

² All internal registers retain data at 0 Hz.

³ "Loss of Reference Frequency" is the reference frequency detected internally, which transitions the PLL into self clocked mode.

Electrical Characteristics

- 4 Self clocked mode frequency is the frequency that the PLL operates at when the reference frequency falls below f_{LOR} with default MFD/RFD settings.
- 5 This parameter is guaranteed by characterization before qualification rather than 100% tested.
- 6 Proper PC board layout procedures must be followed to achieve specifications.
- 7 Load capacitance determined from crystal manufacturer specifications and includes circuit board parasitics.
- 8 This specification applies to the period required for the PLL to relock after changing the MFD frequency control bits in the synthesizer control register (SYNCR).
- 9 Assuming a reference is available at power up, lock time is measured from the time V_{DD} and V_{DDPLL} are valid to \overline{RSTOUT} negating. If the crystal oscillator is being used as the reference for the PLL, then the crystal start up time must be added to the PLL lock time to determine the total start-up time.
- 10 $t_{pll} = (64 * 4 * 5 + 5 * \tau) * T_{ref}$, where $T_{ref} = 1/F_{ref_crystal} = 1/F_{ref_ext} = 1/F_{ref_1:1}$, and $\tau = 1.57 \times 10^{-6} * 2(MFD + 2)$
- 11 PLL is operating in 1:1 PLL mode.
- 12 Jitter is the average deviation from the programmed frequency measured over the specified interval at maximum $f_{sys/2}$. Measurements are made with the device powered by filtered supplies and clocked by a stable external clock signal. Noise injected into the PLL circuitry via V_{DDPLL} and V_{SSPLL} and variation in crystal oscillator frequency increase the jitter percentage for a given interval.
- 13 Based on slow system clock of 33MHz maximum frequency.
- 14 Modulation percentage applies over an interval of 10 μ s, or equivalently the modulation rate is 100KHz.
- 15 Modulation rate selected must not result in $f_{sys/2}$ value greater than the $f_{sys/2}$ maximum specified value. Modulation range determined by hardware design.
- 16 $f_{sys/2} = f_{ico} / (2 * 2^{RFD})$

8.6 External Interface Timing Characteristics

Table 12 lists processor bus input timings.

NOTE

All processor bus timings are synchronous; that is, input setup/hold and output delay with respect to the rising edge of a reference clock. The reference clock is the CLKOUT output.

All other timing relationships can be derived from these values.

Table 12. Processor Bus Input Timing Specifications

Name	Characteristic ¹	Symbol	Min	Max	Unit
B0	CLKOUT	t_{CYC}	12	—	ns
Control Inputs					
B1a	Control input valid to CLKOUT high ²	t_{CVCH}	9	—	ns
B1b	\overline{BKPT} valid to CLKOUT high ³	t_{BKVCH}	9	—	ns
B2a	CLKOUT high to control inputs invalid ²	t_{CHCII}	0	—	ns
B2b	CLKOUT high to asynchronous control input \overline{BKPT} invalid ³	t_{BKNCH}	0	—	ns
Data Inputs					
B4	Data input (D[31:16]) valid to CLKOUT high	t_{DIVCH}	4	—	ns
B5	CLKOUT high to data input (D[31:16]) invalid	t_{CHDII}	0	—	ns

¹ Timing specifications have been indicated taking into account the full drive strength for the pads.

² \overline{TEA} and \overline{TA} pins are being referred to as control inputs.

³ Refer to figure A-19.

Timings listed in Table 12 are shown in Figure 7.

* The timings are also valid for inputs sampled on the negative clock edge.

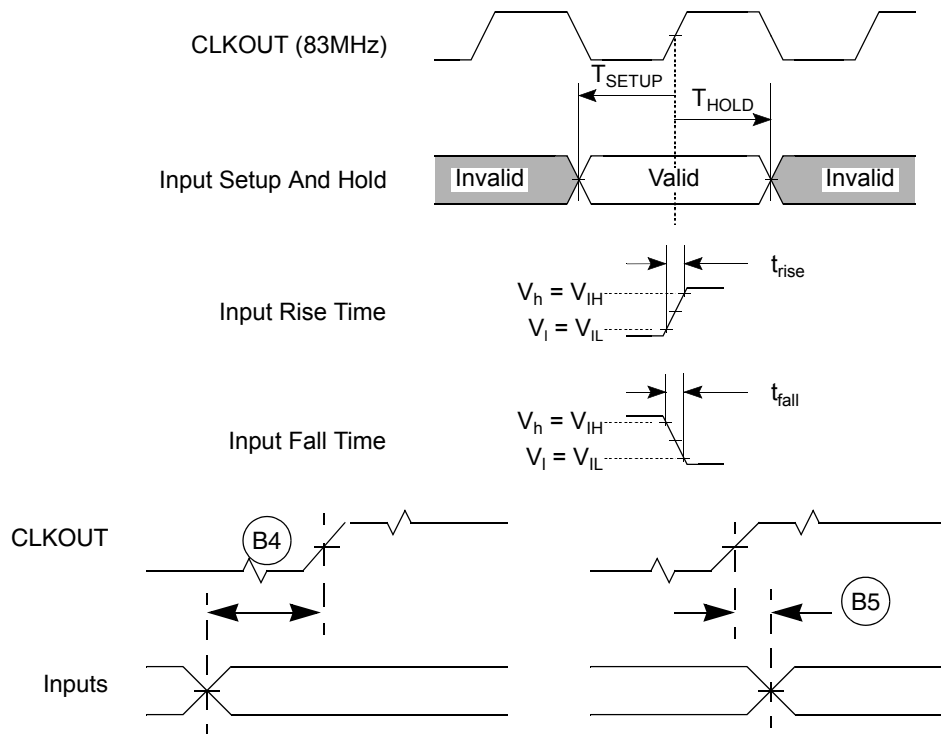

Figure 7. General Input Timing Requirements

8.7 Processor Bus Output Timing Specifications

Table 13 lists processor bus output timings.

Table 13. External Bus Output Timing Specifications

Name	Characteristic	Symbol	Min	Max	Unit
Control Outputs					
B6a	CLKOUT high to chip selects ($\overline{CS}[7:0]$) valid ¹	t_{CHCV}	—	$0.5t_{CYC} + 5.5$	ns
B6b	CLKOUT high to byte enables ($\overline{BS}[3:2]$) valid ¹	t_{CHBV}	—	$0.5t_{CYC} + 5.5$	ns
B6c	CLKOUT high to output enable (\overline{OE}) valid ¹	t_{CHOV}	—	$0.5t_{CYC} + 5.5$	ns
B7	CLKOUT high to control output ($\overline{BS}[3:2]$, \overline{OE}) invalid	t_{CHCOI}	$0.5t_{CYC} + 1.0$	—	ns
B7a	CLKOUT high to chip selects invalid	t_{CHCI}	$0.5t_{CYC} + 1.0$	—	ns
Address and Attribute Outputs					
B8	CLKOUT high to address ($A[23:0]$) and control (\overline{TS} , $TSIZ[1:0]$, \overline{TIP} , R/\overline{W}) valid	t_{CHAV}	—	9	ns
B9	CLKOUT high to address ($A[23:0]$) and control (\overline{TS} , $TSIZ[1:0]$, \overline{TIP} , R/\overline{W}) invalid	t_{CHAI}	1.0	—	ns