



Chipsmall Limited consists of a professional team with an average of over 10 year of expertise in the distribution of electronic components. Based in Hongkong, we have already established firm and mutual-benefit business relationships with customers from,Europe,America and south Asia,supplying obsolete and hard-to-find components to meet their specific needs.

With the principle of “Quality Parts,Customers Priority,Honest Operation,and Considerate Service”,our business mainly focus on the distribution of electronic components. Line cards we deal with include Microchip,ALPS,ROHM,Xilinx,Pulse,ON,Everlight and Freescale. Main products comprise IC,Modules,Potentiometer,IC Socket,Relay,Connector.Our parts cover such applications as commercial,industrial, and automotives areas.

We are looking forward to setting up business relationship with you and hope to provide you with the best service and solution. Let us make a better world for our industry!



Contact us

Tel: +86-755-8981 8866 Fax: +86-755-8427 6832

Email & Skype: info@chipsmall.com Web: www.chipsmall.com

Address: A1208, Overseas Decoration Building, #122 Zhenhua RD., Futian, Shenzhen, China





MCP1256/7/8/9
Charge Pump Evaluation Board
User's Guide

Note the following details of the code protection feature on Microchip devices:

- Microchip products meet the specification contained in their particular Microchip Data Sheet.
- Microchip believes that its family of products is one of the most secure families of its kind on the market today, when used in the intended manner and under normal conditions.
- There are dishonest and possibly illegal methods used to breach the code protection feature. All of these methods, to our knowledge, require using the Microchip products in a manner outside the operating specifications contained in Microchip's Data Sheets. Most likely, the person doing so is engaged in theft of intellectual property.
- Microchip is willing to work with the customer who is concerned about the integrity of their code.
- Neither Microchip nor any other semiconductor manufacturer can guarantee the security of their code. Code protection does not mean that we are guaranteeing the product as "unbreakable."

Code protection is constantly evolving. We at Microchip are committed to continuously improving the code protection features of our products. Attempts to break Microchip's code protection feature may be a violation of the Digital Millennium Copyright Act. If such acts allow unauthorized access to your software or other copyrighted work, you may have a right to sue for relief under that Act.

Information contained in this publication regarding device applications and the like is provided only for your convenience and may be superseded by updates. It is your responsibility to ensure that your application meets with your specifications. MICROCHIP MAKES NO REPRESENTATIONS OR WARRANTIES OF ANY KIND WHETHER EXPRESS OR IMPLIED, WRITTEN OR ORAL, STATUTORY OR OTHERWISE, RELATED TO THE INFORMATION, INCLUDING BUT NOT LIMITED TO ITS CONDITION, QUALITY, PERFORMANCE, MERCHANTABILITY OR FITNESS FOR PURPOSE. Microchip disclaims all liability arising from this information and its use. Use of Microchip devices in life support and/or safety applications is entirely at the buyer's risk, and the buyer agrees to defend, indemnify and hold harmless Microchip from any and all damages, claims, suits, or expenses resulting from such use. No licenses are conveyed, implicitly or otherwise, under any Microchip intellectual property rights.

Trademarks

The Microchip name and logo, the Microchip logo, Accuron, dsPIC, KEELOQ, microID, MPLAB, PIC, PICmicro, PICSTART, PRO MATE, PowerSmart, rfPIC and SmartShunt are registered trademarks of Microchip Technology Incorporated in the U.S.A. and other countries.

AmpLab, FilterLab, Migratable Memory, MXDEV, MXLAB, PICMASTER, SEEVAL, SmartSensor and The Embedded Control Solutions Company are registered trademarks of Microchip Technology Incorporated in the U.S.A.

Analog-for-the-Digital Age, Application Maestro, dsPICDEM, dsPICDEM.net, dsPICworks, ECAN, ECONOMONITOR, FanSense, FlexROM, fuzzyLAB, In-Circuit Serial Programming, ICSP, ICEPIC, Linear Active Thermistor, MPASM, MPLIB, MPLINK, MPSIM, PICKit, PICDEM, PICDEM.net, PICLAB, PICTail, PowerCal, PowerInfo, PowerMate, PowerTool, Real ICE, rFLAB, rPICDEM, Select Mode, Smart Serial, SmartTel, Total Endurance, UNI/O, WiperLock and Zena are trademarks of Microchip Technology Incorporated in the U.S.A. and other countries.

SQTP is a service mark of Microchip Technology Incorporated in the U.S.A.

All other trademarks mentioned herein are property of their respective companies.

© 2006, Microchip Technology Incorporated, Printed in the U.S.A., All Rights Reserved.

 Printed on recycled paper.

QUALITY MANAGEMENT SYSTEM
CERTIFIED BY DNV
== ISO/TS 16949:2002 ==

Microchip received ISO/TS-16949:2002 quality system certification for its worldwide headquarters, design and wafer fabrication facilities in Chandler and Tempe, Arizona and Mountain View, California in October 2003. The Company's quality system processes and procedures are for its PICmicro® 8-bit MCUs, KEELOQ® code hopping devices, Serial EEPROMs, microperipherals, nonvolatile memory and analog products. In addition, Microchip's quality system for the design and manufacture of development systems is ISO 9001:2000 certified.



MCP1256/7/8/9 CHARGE PUMP EVALUATION BOARD USER'S GUIDE

Table of Contents

Preface	1
Chapter 1. Product Overview	5
1.1 Introduction	5
1.2 What is the MCP1256/7/8/9 Charge Pump Evaluation Board?	6
1.3 What the MCP1256/7/8/9 Charge Pump Evaluation Board Includes	6
Chapter 2. Installation and Operation	7
2.1 Introduction	7
2.2 Features	7
2.3 Getting Started	8
Appendix A. Schematic and Layouts	11
A.1 Introduction	11
A.2 Board Schematic	12
A.3 Board - Assembly Drawing	13
A.4 Board - Top Overlay	14
A.5 Board - Top Layer	15
A.6 Board - Bottom Layer	16
Appendix B. Bill Of Materials (BOM)	17
Worldwide Sales and Service	18

MCP1256/7/8/9 Charge Pump Evaluation Board User's Guide

NOTES:



MCP1256/7/8/9 CHARGE PUMP EVALUATION BOARD USER'S GUIDE

Preface

NOTICE TO CUSTOMERS

All documentation becomes dated, and this manual is no exception. Microchip tools and documentation are constantly evolving to meet customer needs, so some actual dialogs and/or tool descriptions may differ from those in this document. Please refer to our web site (www.microchip.com) to obtain the latest documentation available.

Documents are identified with a "DS" number. This number is located on the bottom of each page, in front of the page number. The numbering convention for the DS number is "DSXXXXA", where "XXXX" is the document number and "A" is the revision level of the document.

For the most up-to-date information on development tools, see the MPLAB® IDE on-line help. Select the Help menu, and then Topics to open a list of available on-line help files.

INTRODUCTION

This chapter contains general information that will be useful to know before using the MCP1256/7/8/9 Charge Pump Evaluation Board. Items discussed in this chapter include:

- Document Layout
- Conventions Used in this Guide
- Recommended Reading
- The Microchip Web Site
- Customer Support
- Document Revision History

DOCUMENT LAYOUT

This document describes how to use the MCP1256/7/8/9 Charge Pump Evaluation Board. The manual layout is as follows:

- **Chapter 1. "Product Overview"** – Important information about the MCP1256/7/8/9 Charge Pump Evaluation Board.
- **Chapter 2. "Installation and Operation"** – Includes instructions on how to get started and a description of the MCP1256/7/8/9 Charge Pump Evaluation Board.
- **Appendix A. "Schematic and Layouts"** – Shows the schematic and board layout diagram for the MCP1256/7/8/9 Charge Pump Evaluation Board.
- **Appendix B. "Bill Of Materials (BOM)"** – Lists the parts used to build the MCP1256/7/8/9 Charge Pump Evaluation Board.

MCP1256/7/8/9 Charge Pump Evaluation Board User's Guide

CONVENTIONS USED IN THIS GUIDE

This manual uses the following documentation conventions:

DOCUMENTATION CONVENTIONS

Description	Represents	Examples
Arial font:		
Italic characters	Referenced books	<i>MPLAB[®] IDE User's Guide</i>
	Emphasized text	...is the <i>only</i> compiler...
Initial caps	A window	the Output window
	A dialog	the Settings dialog
	A menu selection	select Enable Programmer
Quotes	A field name in a window or dialog	"Save project before build"
Underlined, italic text with right angle bracket	A menu path	<u><i>File>Save</i></u>
Bold characters	A dialog button	Click OK
	A tab	Click the Power tab
N'Rnnnn	A number in verilog format, where N is the total number of digits, R is the radix and n is a digit.	4'b0010, 2'hF1
Text in angle brackets < >	A key on the keyboard	Press <Enter>, <F1>
Courier New font:		
Plain Courier New	Sample source code	#define START
	Filenames	autoexec.bat
	File paths	c:\mcc18\h
	Keywords	_asm, _endasm, static
	Command-line options	-Opa+, -Opa-
	Bit values	0, 1
	Constants	0xFF, 'A'
Italic Courier New	A variable argument	<i>file.o</i> , where <i>file</i> can be any valid filename
Square brackets []	Optional arguments	mcc18 [options] <i>file</i> [options]
Curly brackets and pipe character: { }	Choice of mutually exclusive arguments; an OR selection	errorlevel {0 1}
Ellipses...	Replaces repeated text	var_name [, var_name...]
	Represents code supplied by user	void main (void) { ... }

RECOMMENDED READING

This user's guide describes how to use the MCP1256/7/8/9 Charge Pump Evaluation Board. Other useful documents are listed below. The following Microchip documents are available and recommended as supplemental reference resources.

MCP1256/7/8/9 Data Sheet, "Regulated 3.3V, Low-Ripple Charge Pump with Low-Operating Current SLEEP Mode or BYPASS Mode" (DS21989)

This data sheet provides detailed information regarding the MCP1256/7/8/9 product family.

THE MICROCHIP WEB SITE

Microchip provides online support via our web site at www.microchip.com. This web site is used as a means to make files and information easily available to customers. Accessible by using your favorite Internet browser, the web site contains the following information:

- **Product Support** – Data sheets and errata, application notes and sample programs, design resources, user's guides and hardware support documents, latest software releases and archived software
- **General Technical Support** – Frequently Asked Questions (FAQs), technical support requests, online discussion groups, Microchip consultant program member listing
- **Business of Microchip** – Product selector and ordering guides, latest Microchip press releases, listing of seminars and events, listings of Microchip sales offices, distributors and factory representatives

CUSTOMER SUPPORT

Users of Microchip products can receive assistance through several channels:

- Distributor or Representative
- Local Sales Office
- Field Application Engineer (FAE)
- Technical Support
- Development Systems Information Line

Customers should contact their distributor, representative or field application engineer (FAE) for support. Local sales offices are also available to help customers. A listing of sales offices and locations is included in the back of this document.

Technical support is available through the web site at: <http://support.microchip.com>

DOCUMENT REVISION HISTORY

Revision A (March 2006)

- Initial Release of this Document.

MCP1256/7/8/9 Charge Pump Evaluation Board User's Guide

NOTES:

Chapter 1. Product Overview

1.1 INTRODUCTION

The MCP1256/7/8/9 Charge Pump Evaluation Board is used to evaluate Microchip's MCP1256/7/8/9 Regulated 3.3V, Low-Ripple Charge Pumps with low-operating current SLEEP mode or BYPASS mode.

This chapter covers the following topics:

- What is the MCP1256/7/8/9 Charge Pump Evaluation Board?
- What the MCP1256/7/8/9 Charge Pump Evaluation Board Includes

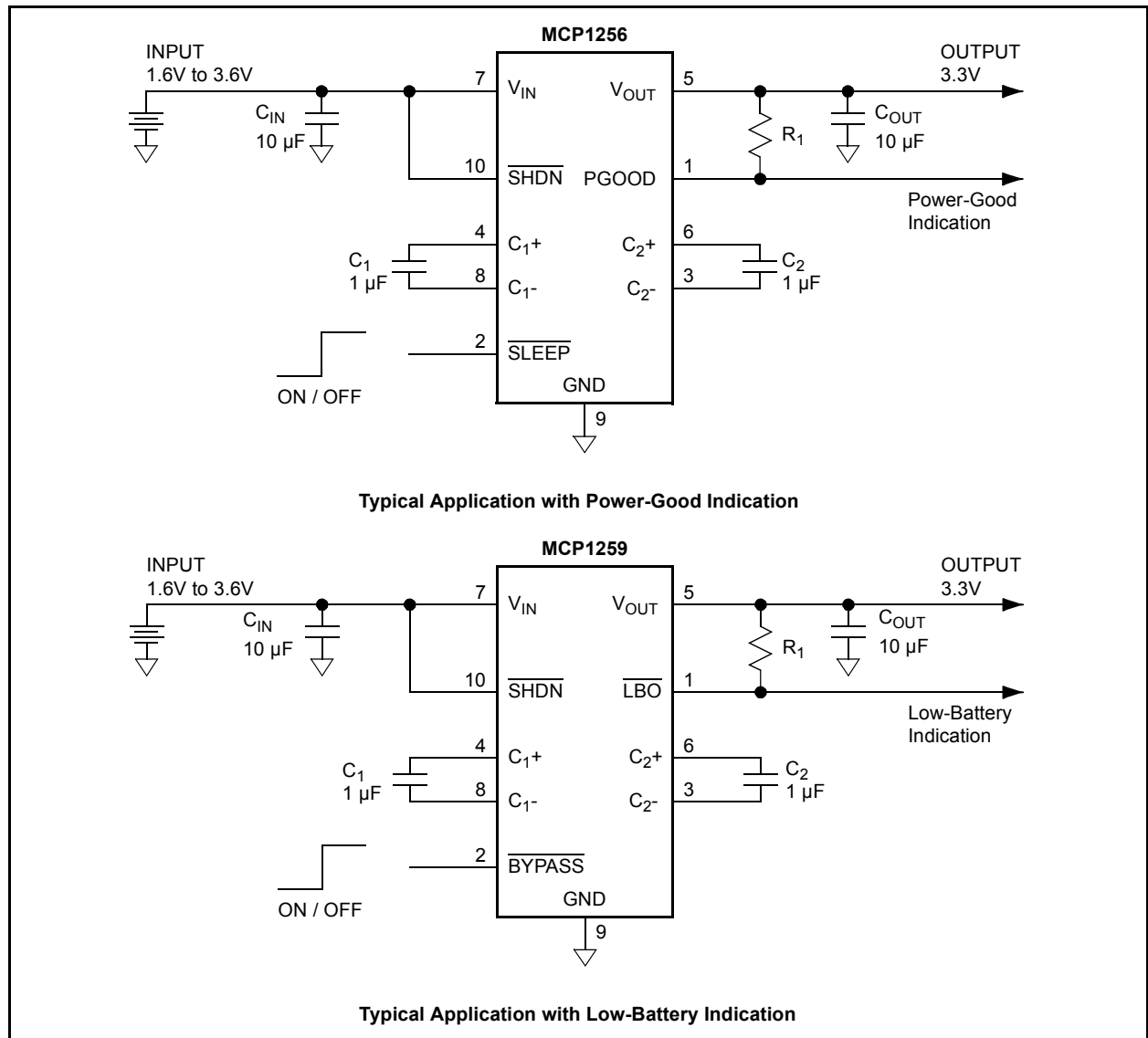

FIGURE 1-1: Typical MCP1256/7/8/9 Applications.

MCP1256/7/8/9 Charge Pump Evaluation Board User's Guide

1.2 WHAT IS THE MCP1256/7/8/9 CHARGE PUMP EVALUATION BOARD?

The MCP1256/7/8/9 Charge Pump Evaluation Board is an evaluation and demonstration tool for Microchip Technology's MCP1256/7/8/9 Regulated 3.3V, Low-Ripple Charge Pumps with low-operating current SLEEP mode or BYPASS mode. The design provides for dynamic versatility.

The MCP1256/7/8/9 Charge Pump Evaluation Board is setup to evaluate simple, stand-alone, DC-to-DC conversion. Two evaluation circuits are provided, demonstrating the versatility of the MCP1256/7/8/9 device family. One evaluation circuit utilizes the MCP1256, demonstrating the SLEEP mode feature along with a power good indication. The other evaluation circuit utilizes the MCP1259, demonstrating the unique BYPASS mode feature, along with a low battery indication.

When connected, the MCP1256/7/8/9 devices can be evaluated in a variety of applications.

1.3 WHAT THE MCP1256/7/8/9 CHARGE PUMP EVALUATION BOARD INCLUDES

This MCP1256/7/8/9 Charge Pump Evaluation Board includes:

- MCP1256/7/8/9 Charge Pump Evaluation Board, 102-00099
- MCP1256/7/8/9 Charge Pump Evaluation Board User's Guide, DS51603
- MCP1256/7/8/9 Data Sheet, "*Regulated 3.3V, Low-Ripple Charge Pump with Low-Operating Current SLEEP Mode or BYPASS Mode*", DS21989



MCP1256/7/8/9 CHARGE PUMP EVALUATION BOARD USER'S GUIDE

Chapter 2. Installation and Operation

2.1 INTRODUCTION

The MCP1256/7/8/9 Charge Pump Evaluation Board demonstrates Microchip's MCP1256/7/8/9 devices. The MCP1256/7/8/9 devices are positive regulated charge pumps that accept an input voltage from +1.8V to +3.6V and convert it to a regulated 3.3V output voltage. The MCP1256/7/8/9 provide a low-cost, compact and simple solution for step-up DC/DC conversions, primarily in battery applications that do not want to use switching regulator solutions because of EMI noise and inductor size.

The MCP1256/7/8/9 are designed to offer the highest possible efficiency under common operating conditions, i.e. $V_{IN} = 2.4V$ or $2.8V$, $V_{OUT} = 3.3V$, $I_{OUT} = 100$ mA. A fixed switching frequency, 650 kHz (typically), allows for easy external filtering.

The MCP1256/7 provide a unique SLEEP mode feature. SLEEP mode reduces the current drawn from the input supply while maintaining a regulated bias on external peripherals. SLEEP mode can substantially increase battery run-time in portable applications.

The MCP1258/9 provide a unique BYPASS mode feature. BYPASS virtually eliminates the current drawn from the input supply by the device, while maintaining an unregulated bias on external peripherals. BYPASS connects the input supply voltage to the output. All remaining functions of the device are shutdown. BYPASS mode can substantially increase battery run-time in portable applications.

The devices supply up to 100 mA of output current for input voltages, V_{IN} , greater than or equal to 2.2V.

2.2 FEATURES

The MCP1256/7/8/9 Charge Pump Evaluation Board is used to evaluate various device options. Two evaluation circuits are provided as a guide to external component selection and board layout. Emphasis has been placed on cost, board area, thermal management and performance. One evaluation circuit utilizes the MCP1256, demonstrating the SLEEP mode feature along with a power good indication. The other evaluation circuit utilizes the MCP1259 demonstrating the unique BYPASS mode feature along with a low-battery indication.

The MCP1256/7/8/9 Charge Pump Evaluation Board has the following features:

- Evaluation of the MCP1256 in a 10-pin MSOP package
- Evaluation of the MCP1259 in a 10-pin MSOP package
- Simple, stand-alone operation
- Powered from external bench supply or compatible battery input
- Surface-mount design
- Fully assembled and tested

MCP1256/7/8/9 Charge Pump Evaluation Board User's Guide

2.3 GETTING STARTED

The MCP1256/7/8/9 Evaluation Board is fully assembled and tested for generating a regulated 3.3V output voltage from a 1.8V to 3.6V input at load currents up to 100 mA. The board requires the use of an external input voltage source and external load.

2.3.1 Power Input and Output Connections

2.3.1.1 POWERING THE MCP1256/7/8/9 EVALUATION BOARD

1. Apply the input voltage source to the appropriate circuit for evaluation. The input voltage source should be limited to the 0V to +3.6V range. For normal operation, the input voltage should be between +1.8V and +3.6V. The input voltage must not exceed an absolute maximum of +3.8V.
2. Connect the positive side of the input source (+) to V_{IN} of the circuit being evaluated. Connect the negative or return side of the input source (-) to GND of the circuit being evaluated. Refer to Figure 2-1.

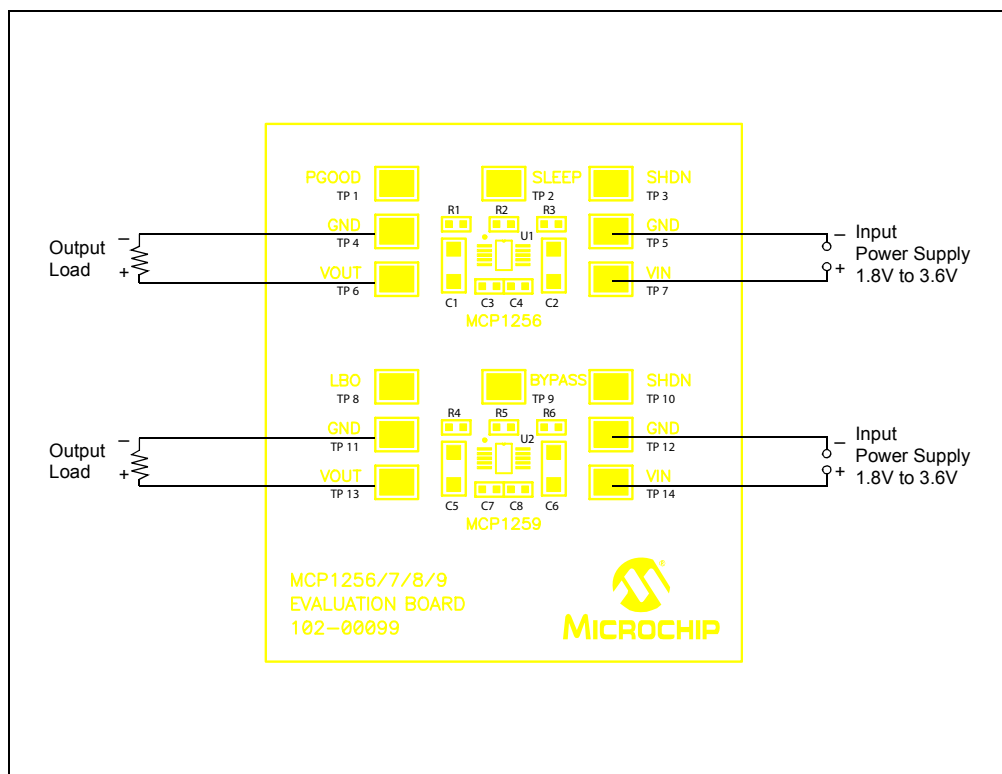

FIGURE 2-1: Setup Configuration Diagram.

2.3.1.2 APPLYING THE LOAD TO THE MCP1256/7/8/9 EVALUATION BOARD

1. To apply a load to a MCP1256/7/8/9 Evaluation Board, the positive side of the load (+) should be connected to V_{OUT} of the circuit being evaluated.
2. The negative or return side of the load (-) should be connected to GND of the circuit being evaluated. Care should be taken when using electronic loads or ground referenced loads.

2.3.2 Shutdown Mode ($\overline{\text{SHDN}}$)

Driving $\overline{\text{SHDN}}$ low puts the MCP1256/7/8/9 in a low-power Shutdown mode. This disables the charge-pump switches, oscillator and control logic, reducing the quiescent current to 0.1 μA (typical). The PGOOD output and LBO are in a high impedance state during shutdown.

2.3.3 SLEEP Mode ($\overline{\text{SLEEP}}$)

The MCP1256/7 provide a unique SLEEP mode feature. SLEEP mode reduces the current drawn from the input supply, while maintaining a regulated bias on external peripherals. SLEEP mode can substantially increase battery run-time in portable applications.

The regulation control is hysteretic, otherwise referred to as a bang-bang control. The output is regulated around a fixed reference with some hysteresis. As a result, some amount of peak-to-peak ripple will be observed at the output independent of load current. The frequency of the output ripple, however, will be influenced heavily by the load current and output capacitance.

2.3.4 BYPASS Mode ($\overline{\text{BYPASS}}$)

The MCP1258/9 provide a unique BYPASS mode feature. BYPASS virtually eliminates the current drawn from the input supply by the device, while maintaining an unregulated bias on external peripherals. BYPASS connects the input supply voltage to the output. All remaining functions of the device are shutdown. BYPASS mode can substantially increase battery run-time in portable applications.

2.3.5 Device Support Options

The MCP1256/7/8/9 Charge Pump Evaluation Board supports the entire MCP1256/7/8/9 family. The MCP1256/7/8/9 Charge Pump Evaluation Board is provided with two evaluation circuits utilizing the MCP1256 and MCP1259. Alternate devices can be substituted in order to evaluate the different MCP1256/7/8/9 family options.

MCP1256/7/8/9 Charge Pump Evaluation Board User's Guide

NOTES:



MCP1256/7/8/9 CHARGE PUMP EVALUATION BOARD USER'S GUIDE

Appendix A. Schematic and Layouts

A.1 INTRODUCTION

This appendix contains the following schematic and layouts for the MCP1256/7/8/9 Charge Pump Evaluation Board.

Diagrams included in this appendix:

- Board Schematic
- Board - Assembly Drawing
- Board - Top Overlay
- Board - Top Layer
- Board - Bottom Layer

MCP1256/7/8/9 Charge Pump Evaluation Board User's Guide

A.2 BOARD SCHEMATIC

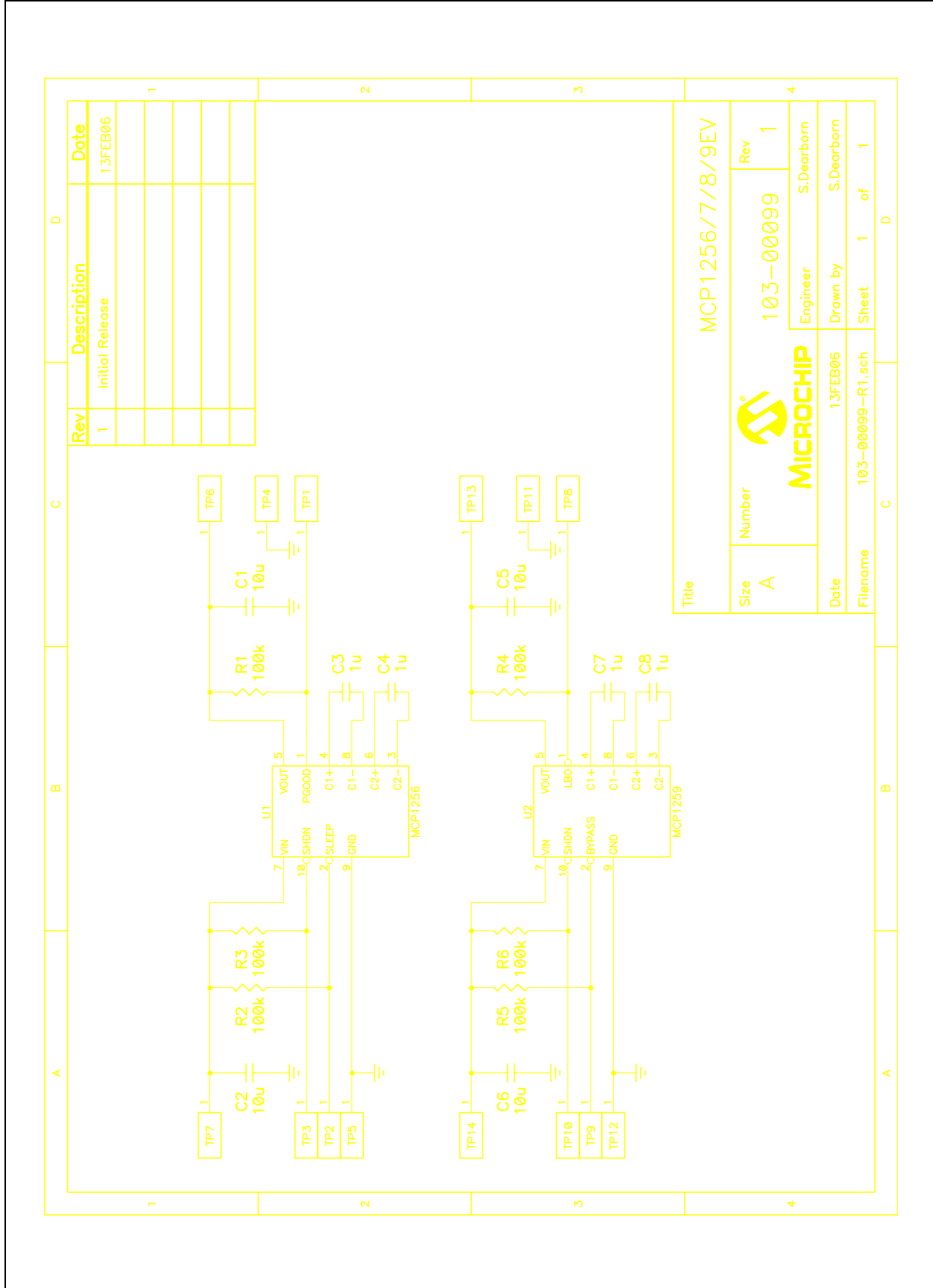

A.3 BOARD - ASSEMBLY DRAWING

A	B	C	D
1	2	3	4

NOTES:

MATERIAL: FR-4, THICKNESS: 0.062, COPPER: 1 OZ - SIG LYRS

TWO LAYER BOARD

FINISH: SOLDERMASK OVER BARE COPPER (SMOBC) WITH HOT-AIR-LEVELLED SOLDER
 SMOBC WITH SELECTIVE GOLD PLATING ON LANDS INDICATED, 10µl GOLD OVER 50-100µl NICKEL.
 60/40 TIN-LEAD REFLOW

SOLDERMASK - DYNACHEM EPIC 200 LPI OR EQUIVALENT.
 COLOR-Green High Gloss
 SILKSCREEN - White

USE ARTWORK SET NO. 105-00099 REV 1

ANY ALTERNATIVES TO THE ABOVE SPECIFICATIONS MUST BE APPROVED BY THE ENGINEERING DEPARTMENT AT MICROCHIP.

THIS PCB TO BE MANUFACTURED TO MEET ALL ACCEPTANCE LEVELS OF A CLASS 2 PCB PER ANSI/IPC-A-600F.

ASSEMBLY NOTES:

1. ALL UNUSED COMPONENTS SHALL BE FREE OF SOLDER
2. ALL COMPONENTS SHALL BE MOUNTED FLUSH TO THE BOARD, EXCEPT AS NOTED.
3. MAXIMUM COMPONENT HEIGHT NOT TO EXCEED: 0.500 TOP SIDE, 0.048 BOTTOM SIDE
4. FINISHED BOARD SHALL BE FREE OF ALL RESIDUES.

REV	DESCRIPTION	DATE
1	Initial Design	13FEB06

Title		MCP1256/7/8/9EV	
Size	Number	Rev	
B	MICROCHIP	104-00099	1
Date	Engineer	Drawn by	S.Deebom
13FEB06	104-00099-R1.pcb	Sheet	1 of 1

Drill Table

Hole Dia. (inch)	Symbol	Quantity	Plated
0.014	+	24	Yes

MCP1256/7/8/9 Charge Pump Evaluation Board User's Guide

A.4 BOARD - TOP OVERLAY

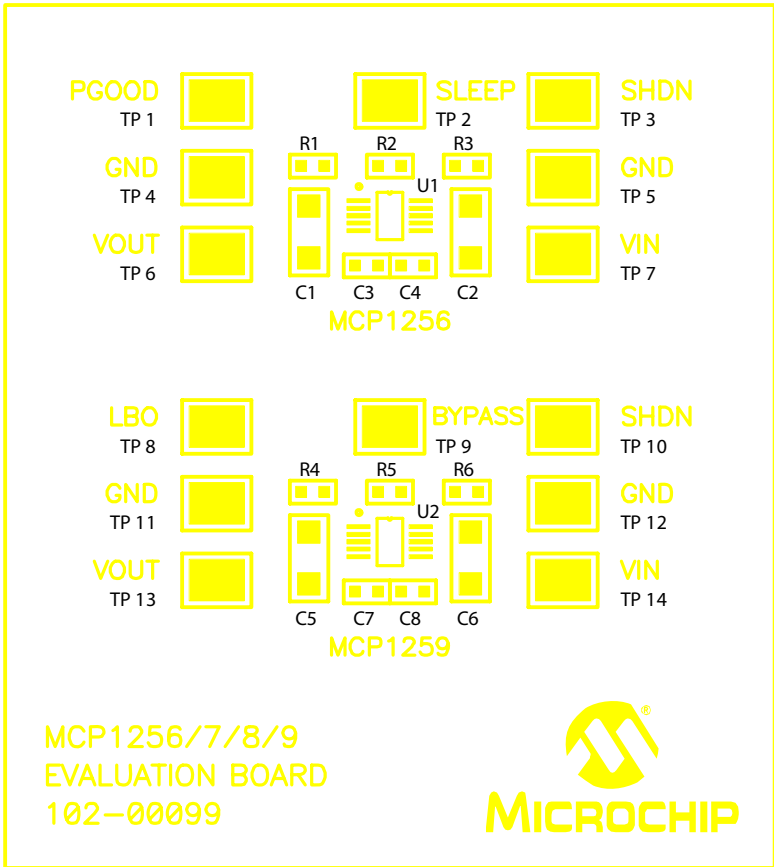

A.5 BOARD - TOP LAYER

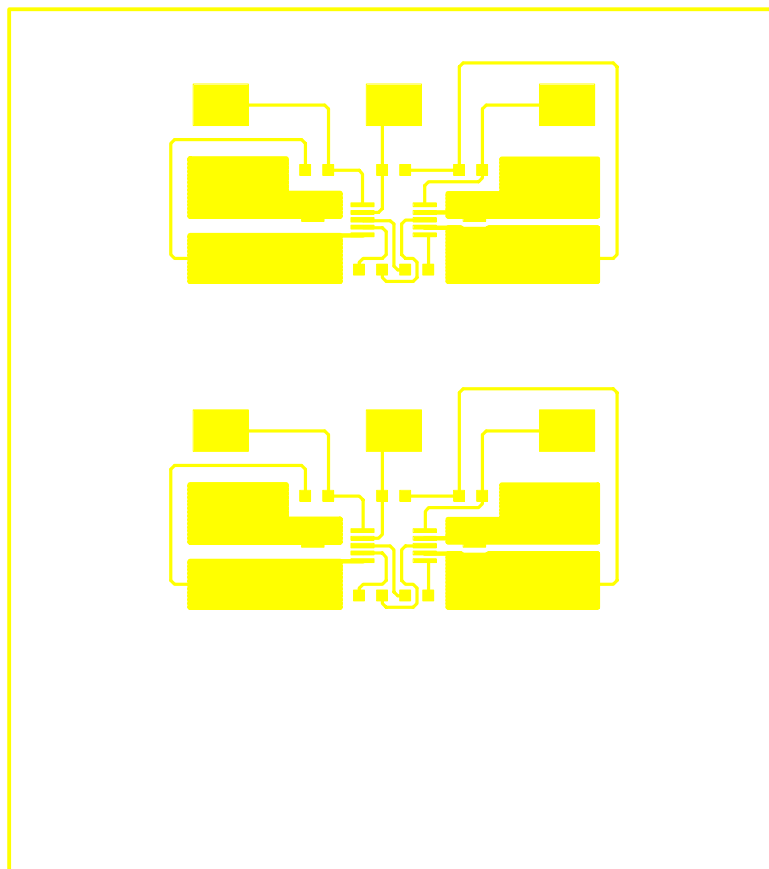

A.6 BOARD - BOTTOM LAYER

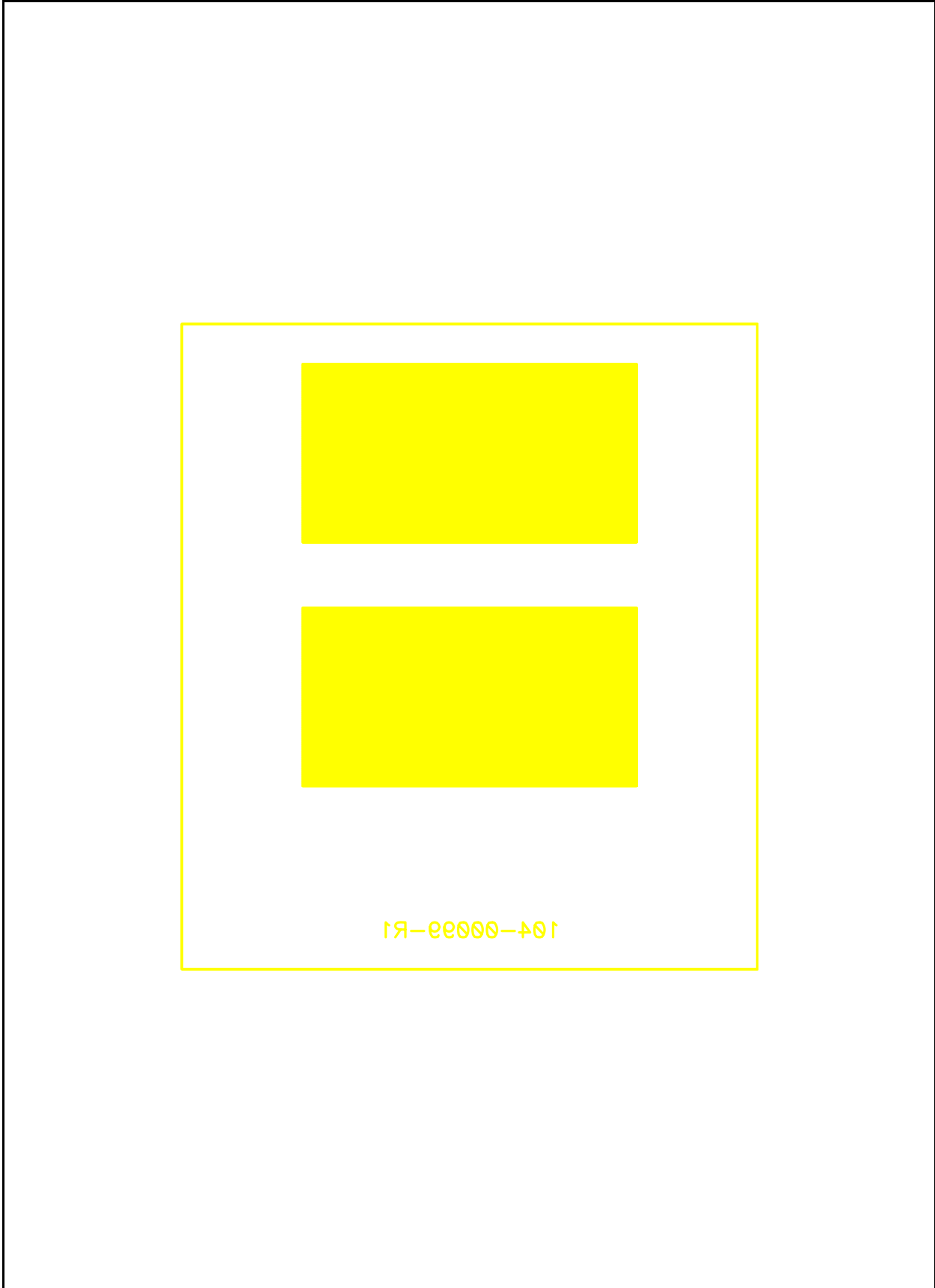

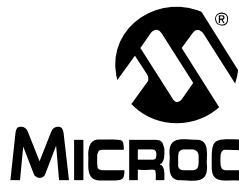

MCP1256/7/8/9 CHARGE PUMP EVALUATION BOARD USER'S GUIDE

Appendix B. Bill Of Materials (BOM)

TABLE B-1: BILL OF MATERIALS (BOM)

Qty.	Reference	Description	Mfgr.	Part Number
4	C1,C2,C5,C6	10uF, X5R Ceramic, 10V, 1206	Taiyo Yuden®	LMK316BJ106KL-T
4	C3,C4,C7,C8	1uF, X7R Ceramic, 16V, 0603	Taiyo Yuden	EMK107BJ105KA-TR
6	R1,R2,R3,R4,R5,R6	100k, 1/10W, Chip Resistor, 0603	Panasonic®-ECG	ERJ-3EK1003V
12	TP1-TP12	Surface Mount Test Point, 5016	Keystone® Electronics	5016
1	U1	Positive Regulated Charge Pump, MSOP10	Microchip Technology, Inc.	MCP1256-I/MS
1	U2	Positive Regulated Charge Pump, MSOP10	Microchip Technology, Inc.	MCP1259-I/MS
4	—	Bump-ons	3M	SJ5003
1	—	Printed Circuit Board	Advanced Circuits	104-00099-R1



WORLDWIDE SALES AND SERVICE

AMERICAS

Corporate Office
2355 West Chandler Blvd.
Chandler, AZ 85224-6199
Tel: 480-792-7200
Fax: 480-792-7277
Technical Support:
<http://support.microchip.com>
Web Address:
www.microchip.com

Atlanta
Alpharetta, GA
Tel: 770-640-0034
Fax: 770-640-0307

Boston
Westborough, MA
Tel: 774-760-0087
Fax: 774-760-0088

Chicago
Itasca, IL
Tel: 630-285-0071
Fax: 630-285-0075

Dallas
Addison, TX
Tel: 972-818-7423
Fax: 972-818-2924

Detroit
Farmington Hills, MI
Tel: 248-538-2250
Fax: 248-538-2260

Kokomo
Kokomo, IN
Tel: 765-864-8360
Fax: 765-864-8387

Los Angeles
Mission Viejo, CA
Tel: 949-462-9523
Fax: 949-462-9608

San Jose
Mountain View, CA
Tel: 650-215-1444
Fax: 650-961-0286

Toronto
Mississauga, Ontario,
Canada
Tel: 905-673-0699
Fax: 905-673-6509

ASIA/PACIFIC

Australia - Sydney
Tel: 61-2-9868-6733
Fax: 61-2-9868-6755

China - Beijing
Tel: 86-10-8528-2100
Fax: 86-10-8528-2104

China - Chengdu
Tel: 86-28-8676-6200
Fax: 86-28-8676-6599

China - Fuzhou
Tel: 86-591-8750-3506
Fax: 86-591-8750-3521

China - Hong Kong SAR
Tel: 852-2401-1200
Fax: 852-2401-3431

China - Qingdao
Tel: 86-532-8502-7355
Fax: 86-532-8502-7205

China - Shanghai
Tel: 86-21-5407-5533
Fax: 86-21-5407-5066

China - Shenyang
Tel: 86-24-2334-2829
Fax: 86-24-2334-2393

China - Shenzhen
Tel: 86-755-8203-2660
Fax: 86-755-8203-1760

China - Shunde
Tel: 86-757-2839-5507
Fax: 86-757-2839-5571

China - Wuhan
Tel: 86-27-5980-5300
Fax: 86-27-5980-5118

China - Xian
Tel: 86-29-8833-7250
Fax: 86-29-8833-7256

ASIA/PACIFIC

India - Bangalore
Tel: 91-80-4182-8400
Fax: 91-80-4182-8422

India - New Delhi
Tel: 91-11-5160-8631
Fax: 91-11-5160-8632

India - Pune
Tel: 91-20-2566-1512
Fax: 91-20-2566-1513

Japan - Yokohama
Tel: 81-45-471-6166
Fax: 81-45-471-6122

Korea - Gumi
Tel: 82-54-473-4301
Fax: 82-54-473-4302

Korea - Seoul
Tel: 82-2-554-7200
Fax: 82-2-558-5932 or
82-2-558-5934

Malaysia - Penang
Tel: 60-4-646-8870
Fax: 60-4-646-5086

Philippines - Manila
Tel: 63-2-634-9065
Fax: 63-2-634-9069

Singapore
Tel: 65-6334-8870
Fax: 65-6334-8850

Taiwan - Hsin Chu
Tel: 886-3-572-9526
Fax: 886-3-572-6459

Taiwan - Kaohsiung
Tel: 886-7-536-4818
Fax: 886-7-536-4803

Taiwan - Taipei
Tel: 886-2-2500-6610
Fax: 886-2-2508-0102

Thailand - Bangkok
Tel: 66-2-694-1351
Fax: 66-2-694-1350

EUROPE

Austria - Wels
Tel: 43-7242-2244-399
Fax: 43-7242-2244-393

Denmark - Copenhagen
Tel: 45-4450-2828
Fax: 45-4485-2829

France - Paris
Tel: 33-1-69-53-63-20
Fax: 33-1-69-30-90-79

Germany - Munich
Tel: 49-89-627-144-0
Fax: 49-89-627-144-44

Italy - Milan
Tel: 39-0331-742611
Fax: 39-0331-466781

Netherlands - Drunen
Tel: 31-416-690399
Fax: 31-416-690340

Spain - Madrid
Tel: 34-91-708-08-90
Fax: 34-91-708-08-91

UK - Wokingham
Tel: 44-118-921-5869
Fax: 44-118-921-5820