



Chipsmall Limited consists of a professional team with an average of over 10 year of expertise in the distribution of electronic components. Based in Hongkong, we have already established firm and mutual-benefit business relationships with customers from,Europe,America and south Asia,supplying obsolete and hard-to-find components to meet their specific needs.

With the principle of "Quality Parts,Customers Priority,Honest Operation,and Considerate Service",our business mainly focus on the distribution of electronic components. Line cards we deal with include Microchip,ALPS,ROHM,Xilinx,Pulse,ON,Everlight and Freescale. Main products comprise IC,Modules,Potentiometer,IC Socket,Relay,Connector.Our parts cover such applications as commercial,industrial, and automotives areas.

We are looking forward to setting up business relationship with you and hope to provide you with the best service and solution. Let us make a better world for our industry!



Contact us

Tel: +86-755-8981 8866 Fax: +86-755-8427 6832

Email & Skype: info@chipsmall.com Web: www.chipsmall.com

Address: A1208, Overseas Decoration Building, #122 Zhenhua RD., Futian, Shenzhen, China



2.0 MHz, 500 mA Synchronous Buck Regulator with Power-Good

Features

- Over 90% Typical Efficiency
- Output Current: Up To 500 mA
- Power-Good Output with 262 ms Delay
- Low Quiescent Current: 45 μ A (typical)
- Low Shutdown Current: 0.05 μ A (typical)
- Automatic PWM to PFM Mode Transition
- Adjustable Output Voltage:
 - 0.8V to 4.5V
- Fixed Output Voltage:
 - 1.2V, 1.5V, 1.8V, 2.5V, and 3.3V
- 2.0 MHz Fixed-Frequency PWM (Heavy Load)
- Internally Compensated
- Undervoltage Lockout (UVLO)
- Overtemperature Protection
- Overcurrent Protection
- Space Saving Packages:
 - 8-Lead MSOP
 - 8-Lead 3x3 DFN

Applications

- Cellular Telephones
- Portable Computers
- Organizers / PDAs
- USB Powered Devices
- Digital Cameras
- Portable Equipment
- +5V or +3.3V Distributed Systems

General Description

The MCP1602 is a high efficient, fully integrated 500 mA synchronous buck regulator with a power-good monitor. The 2.7V to 5.5V input voltage range and low quiescent current (45 μ A, typical) makes the MCP1602 ideally suited for applications powered from 1-cell Li-Ion or 2-cell/3-cell NiMH/NiCd batteries.

At heavy loads, the MCP1602 operates in the 2.0 MHz fixed frequency PWM mode which provides a low noise, low output ripple, small-size solution. When the load is reduced to light levels, the MCP1602 automatically changes operation to a PFM mode to minimize quiescent current draw from the battery. No intervention is necessary for a smooth transition from one mode to another. These two modes of operation allow the MCP1602 to achieve the highest efficiency over the entire operating current range.

The open-drain power-good feature of the MCP1602 monitors the output voltage and provides indication when the output voltage is within 94% (typical) of the regulation value. The typical 2% hysteresis in the power-good transition threshold as well as a 262 ms (typical) delay time ensures accurate power-good signaling.

The MCP1602 is available in either the 8-pin DFN or MSOP package. It is also available with either an adjustable or fixed output voltage. The available fixed output voltage options are 1.2V, 1.5V, 1.8V, 2.5V, and 3.3V.

Additional protection features include: UVLO, overtemperature, and overcurrent protection.

Package Types

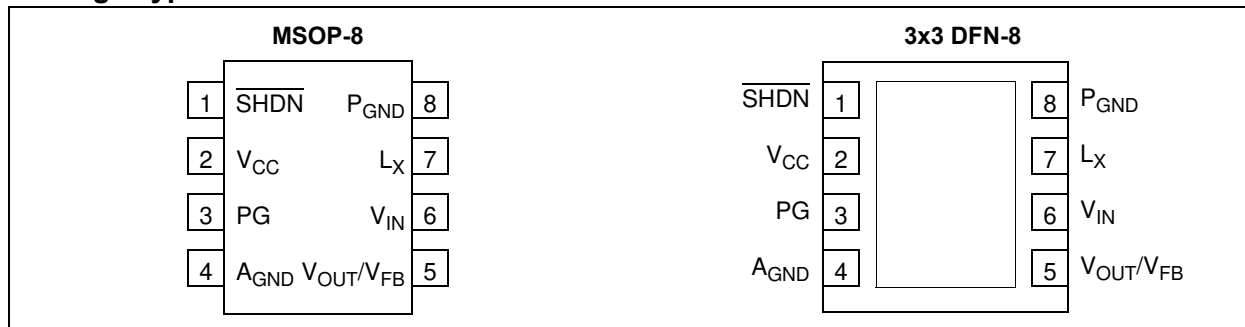

MCP1602

Typical Application Circuit

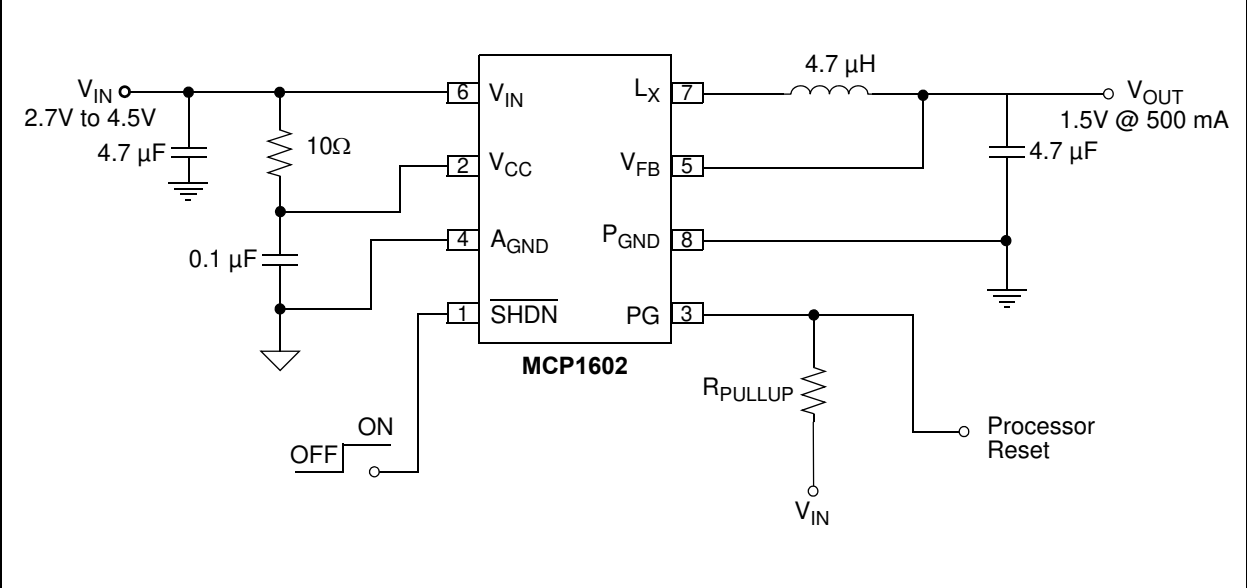

Functional Block Diagram

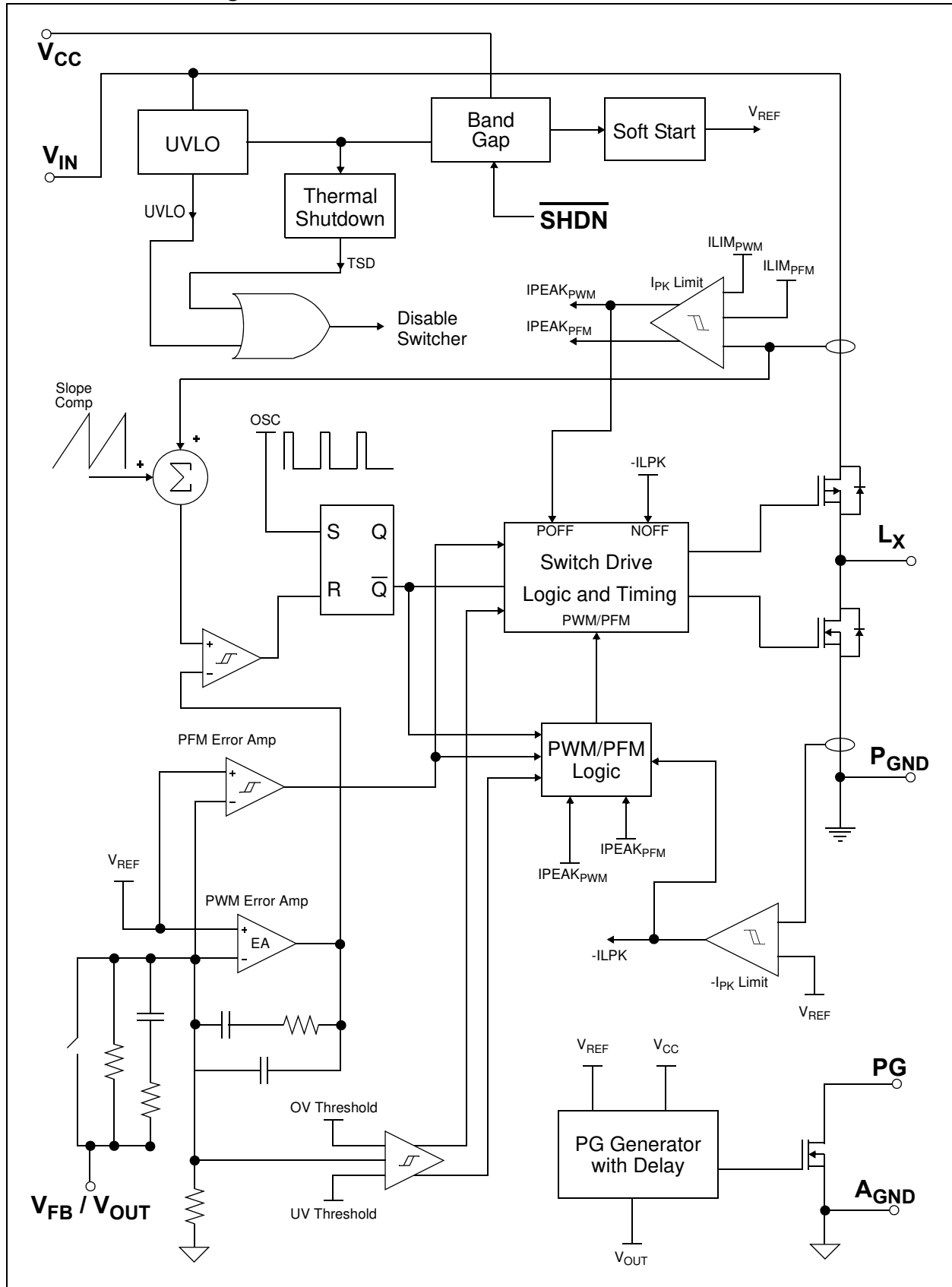

MCP1602

1.0 ELECTRICAL CHARACTERISTICS

Absolute Maximum Ratings †

$V_{IN} - A_{GND}$	+6.0V
All Other I/O	($A_{GND} - 0.3V$) to ($V_{IN} + 0.3V$)
LX to P_{GND}	-0.3V to ($V_{IN} + 0.3V$)
Output Short Circuit Current.....	Continuous
Power Dissipation (Note 6)	Internally Limited
Storage Temperature.....	-65°C to +150°C
Ambient Temp. with Power Applied.....	-40°C to +85°C
Operating Junction Temperature.....	-40°C to +125°C
ESD Protection On All Pins:	
HBM.....	3 kV
MM.....	200V

† **Notice:** Stresses above those listed under "Maximum Ratings" may cause permanent damage to the device. This is a stress rating only and functional operation of the device at those or any other conditions above those indicated in the operational sections of this specification is not intended. Exposure to maximum rating conditions for extended periods may affect device reliability.

DC CHARACTERISTICS

Electrical Characteristics: Unless otherwise indicated, $V_{IN} = 3.6V$, $C_{OUT} = C_{IN} = 4.7 \mu F$, $L = 4.7 \mu H$, $V_{OUT}(ADJ) = 1.8V$, $I_{OUT} = 100 \text{ mA}$, $T_A = +25^\circ C$. Boldface specifications apply for the T_A range of -40°C to +85°C .						
Parameters	Sym	Min	Typ	Max	Units	Conditions
Input Characteristics						
Input Voltage	V_{IN}	2.7	—	5.5	V	Note 1
Maximum Output Current	I_{OUT}	500	—	—	mA	Note 1
Shutdown Current	$I_{IN \overline{SHDN}}$	—	0.05	1	μA	$\overline{SHDN} = GND$
Quiescent Current	I_Q	—	45	60	μA	$\overline{SHDN} = V_{IN}$, $I_{OUT} = 0 \text{ mA}$
Shutdown/UVLO/Thermal Shutdown Characteristics						
SHDN, Logic Input Voltage Low	V_{IL}	—	—	15	% V_{IN}	$V_{IN} = 2.7V$ to $5.5V$
SHDN, Logic Input Voltage High	V_{IH}	45	—	—	% V_{IN}	$V_{IN} = 2.7V$ to $5.5V$
SHDN, Input Leakage Current	$V_L \overline{SHDN}$	-1.0	± 0.1	1.0	μA	$V_{IN} = 2.7V$ to $5.5V$, $\overline{SHDN} = A_{GND}$
Undervoltage Lockout	UVLO	2.40	2.55	2.70	V	V_{IN} Falling
Undervoltage Lockout Hysteresis	UVLO _{HYS}	—	200	—	mV	
Thermal Shutdown	T_{SHD}	—	150	—	°C	Note 5, Note 6
Thermal Shutdown Hysteresis	$T_{SHD-HYS}$	—	10	—	°C	Note 5, Note 6
Output Characteristics						
Adjustable Output Voltage Range	V_{OUT}	0.8	—	4.5	V	Note 2
Reference Feedback Voltage	V_{FB}	—	0.8	—	V	
Feedback Input Bias Current	I_{VFB}	—	-1.5	—	nA	

- Note 1:** The minimum V_{IN} has to meet two conditions: $V_{IN} \geq 2.7V$ and $V_{IN} \geq V_{OUT} + 0.5V$.
- 2:** Reference Feedback Voltage Tolerance applies to adjustable output voltage setting.
- 3:** V_R is the output voltage setting.
- 4:** Regulation is measured at a constant junction temperature using low duty cycle pulse testing. Load regulation is tested over a load range of 0.1 mA to the maximum specified output current. Changes in output voltage due to heating effects are covered by the thermal regulation specification.
- 5:** The maximum allowable power dissipation is a function of ambient temperature, the maximum allowable temperature and the thermal resistance from junction to air (i.e. T_A , T_J , θ_{JA}). Exceeding the maximum allowable power dissipation causes the device to initiate thermal shutdown.
- 6:** The internal MOSFET switches have an integral diode from the L_X pin to the V_{IN} pin, and from the L_X pin to the GND pin. In cases where these diodes are forward-biased, the package power dissipation limits must be adhered to. Thermal protection is not able to limit the junction temperature for these cases.
- 7:** The current limit threshold is a cycle-by-cycle current limit.

DC CHARACTERISTICS (CONTINUED)

Electrical Characteristics: Unless otherwise indicated, $V_{IN} = 3.6V$, $C_{OUT} = C_{IN} = 4.7 \mu F$, $L = 4.7 \mu H$, $V_{OUT}(ADJ) = 1.8V$, $I_{OUT} = 100 \text{ mA}$, $T_A = +25^\circ C$. **Boldface** specifications apply for the T_A range of **-40°C to +85°C**.

Parameters	Sym	Min	Typ	Max	Units	Conditions
Output Voltage Tolerance Fixed	V_{OUT}	-2.5	V_R	+2.5	%	Note 3
Line Regulation	$V_{LINE-REG}$	—	0.3	—	%/V	$V_{IN} = V_R + 1V$ to 5.5V, $I_{OUT} = 100 \text{ mA}$
Load Regulation	$V_{LOAD-REG}$	—	0.4	—	%	$V_{IN} = V_R + 1.5V$, $I_{LOAD} = 100 \text{ mA}$ to 500 mA, Note 1
Internal Oscillator Frequency	F_{OSC}	1.6	2.0	2.4	MHz	
Start Up Time	T_{SS}	—	0.5	—	ms	$T_R = 10\%$ to 90%
R_{DSon} P-Channel	R_{DSon-P}	—	450	—	m Ω	$I_P = 100 \text{ mA}$
R_{DSon} N-Channel	R_{DSon-N}	—	450	—	m Ω	$I_N = 100 \text{ mA}$
L_X Pin Leakage Current	I_{LX}	-1.0	± 0.01	1.0	μA	$SHDN = 0V$, $V_{IN} = 5.5V$, $L_X = 0V$, $L_X = 5.5V$
Positive Current Limit Threshold	$+I_{LX(MAX)}$	—	700	—	mA	Note 7
Power-Good (PG)						
Voltage Range	V_{PG}	1.0 1.2	—	5.5 5.5	V	$T_A = 0^\circ C$ to $+70^\circ C$ $T_A = -40^\circ C$ to $+85^\circ C$ $V_{IN} \leq 2.7V$, $I_{SINK} = 100 \mu A$
PG Threshold High	V_{TH_H}	—	94	96	% of V_{OUT}	On Rising V_{OUT}
PG Threshold Low	V_{TH_L}	89	92	—	% of V_{OUT}	On Falling V_{OUT}
PG Threshold Hysteresis	V_{TH_HYS}	—	2	—	% of V_{OUT}	
PG Threshold Tempco	$\Delta V_{TH}/\Delta T$	—	30	—	ppm/ $^\circ C$	
PG Delay	t_{RPD}	—	165	—	μs	$V_{OUT} = (V_{TH_H} + 100 \text{ mV})$ to $(V_{TH_L} - 100 \text{ mV})$
PG Active Time-out Period	t_{RPU}	140	262	560	ms	$V_{OUT} = (V_{TH_L} - 100 \text{ mV})$ to $(V_{TH_H} + 100 \text{ mV})$, $I_{SINK} = 1.2\text{mA}$
PG Output Voltage Low	PG_VOL	—	—	0.2	V	$V_{OUT} = V_{TH_L} - 100 \text{ mV}$, $I_{PG} = 1.2 \text{ mA}$, $V_{IN} > 2.7V$ $I_{PG} = 100 \mu A$, $1.0 < V_{IN} < 2.7V$

Note 1: The minimum V_{IN} has to meet two conditions: $V_{IN} \geq 2.7V$ and $V_{IN} \geq V_{OUT} + 0.5V$.

2: Reference Feedback Voltage Tolerance applies to adjustable output voltage setting.

3: V_R is the output voltage setting.

4: Regulation is measured at a constant junction temperature using low duty cycle pulse testing. Load regulation is tested over a load range of 0.1 mA to the maximum specified output current. Changes in output voltage due to heating effects are covered by the thermal regulation specification.

5: The maximum allowable power dissipation is a function of ambient temperature, the maximum allowable temperature and the thermal resistance from junction to air (i.e. T_A , T_J , θ_{JA}). Exceeding the maximum allowable power dissipation causes the device to initiate thermal shutdown.

6: The internal MOSFET switches have an integral diode from the L_X pin to the V_{IN} pin, and from the L_X pin to the GND pin. In cases where these diodes are forward-biased, the package power dissipation limits must be adhered too. Thermal protection is not able to limit the junction temperature for these cases.

7: The current limit threshold is a cycle-by-cycle current limit.

MCP1602

TEMPERATURE SPECIFICATIONS

Electrical Specifications: Unless otherwise indicated, all limits are specified for: $V_{IN} + 2.7V$ to $5.5V$						
Parameters	Sym	Min	Typ	Max	Units	Conditions
Temperature Ranges						
Operating Junction Temperature Range	T_J	-40	—	+125	°C	Steady State
Storage Temperature Range	T_A	-65	—	+150	°C	
Maximum Junction Temperature	T_J	—	—	+150	°C	Transient
Package Thermal Resistances						
Thermal Resistance, 8L-MSOP	θ_{JA}	—	211	—	°C/W	Typical 4-layer Board with Internal Ground Plane
Thermal Resistance, 8L-3x3 DFN	θ_{JA}	—	60	—	°C/W	Typical 4-layer Board with Internal Ground Plane and 2-Vias in Thermal Pad

2.0 TYPICAL PERFORMANCE CURVES

Note: The graphs and tables provided following this note are a statistical summary based on a limited number of samples and are provided for informational purposes only. The performance characteristics listed herein are not tested or guaranteed. In some graphs or tables, the data presented may be outside the specified operating range (e.g., outside specified power supply range) and therefore outside the warranted range.

Note: Unless otherwise indicated, $V_{IN} = \overline{\text{SHDN}} = 3.6\text{V}$, $C_{OUT} = C_{IN} = 4.7\ \mu\text{F}$, $L = 4.7\ \mu\text{H}$, $V_{OUT}(\text{ADJ}) = 1.8\text{V}$, $I_{LOAD} = 100\ \text{mA}$, $T_A = +25^\circ\text{C}$. Adjustable or fixed output voltage options can be used to generate the Typical Performance Characteristics.

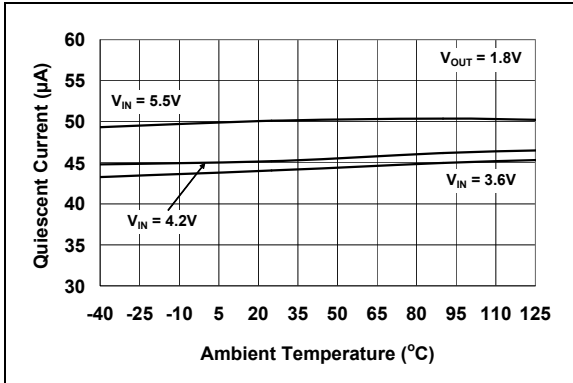

FIGURE 2-1: I_Q vs. Ambient Temperature.

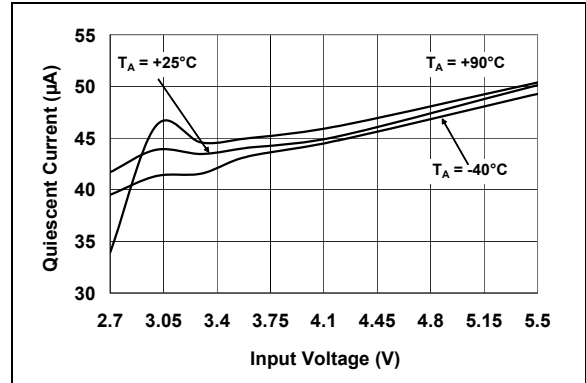

FIGURE 2-4: I_Q vs. Input Voltage.

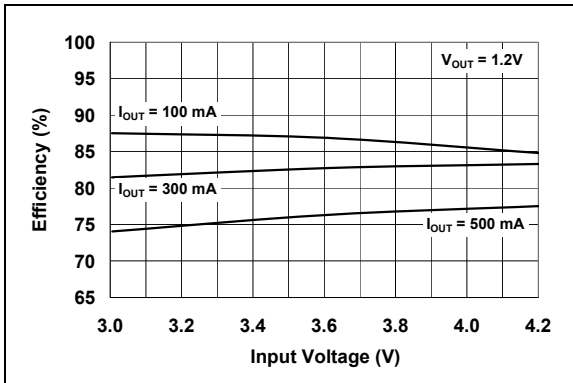

FIGURE 2-2: Efficiency vs. Input Voltage ($V_{OUT} = 1.2\text{V}$).

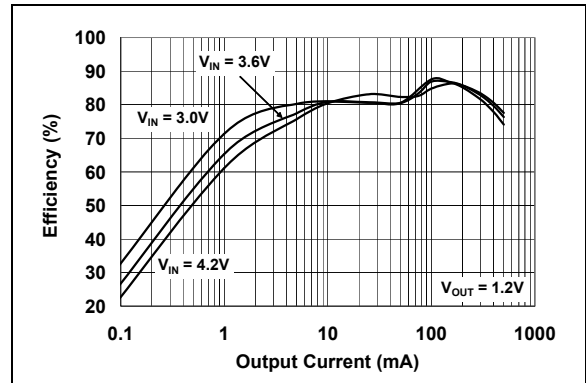

FIGURE 2-5: Efficiency vs. Output Load ($V_{OUT} = 1.2\text{V}$).

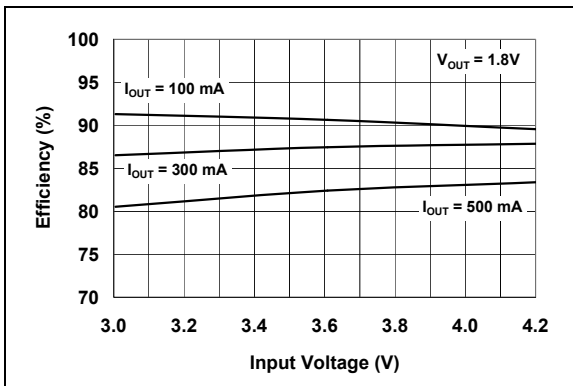

FIGURE 2-3: Efficiency vs. Input Voltage ($V_{OUT} = 1.8\text{V}$).

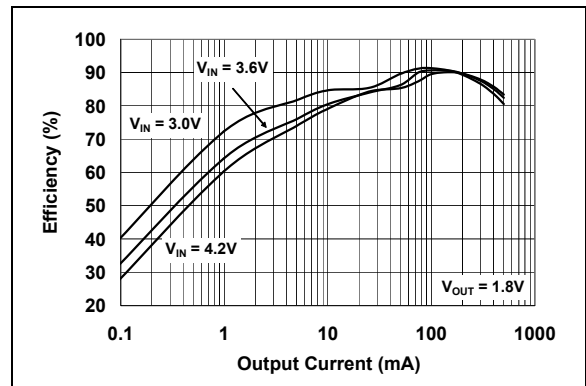

FIGURE 2-6: Efficiency vs. Output Load ($V_{OUT} = 1.8\text{V}$).

MCP1602

Typical Performance Curves (Continued)

Note: Unless otherwise indicated, $V_{IN} = \overline{\text{SHDN}} = 3.6\text{V}$, $C_{OUT} = C_{IN} = 4.7\ \mu\text{F}$, $L = 4.7\ \mu\text{H}$, $V_{OUT(\text{ADJ})} = 1.8\text{V}$, $I_{LOAD} = 100\ \text{mA}$, $T_A = +25^\circ\text{C}$. Adjustable or fixed output voltage options can be used to generate the Typical Performance Characteristics.

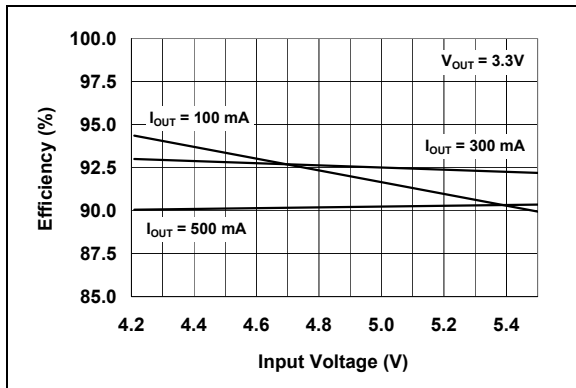

FIGURE 2-7: Efficiency vs. Input Voltage ($V_{OUT} = 3.3\text{V}$).

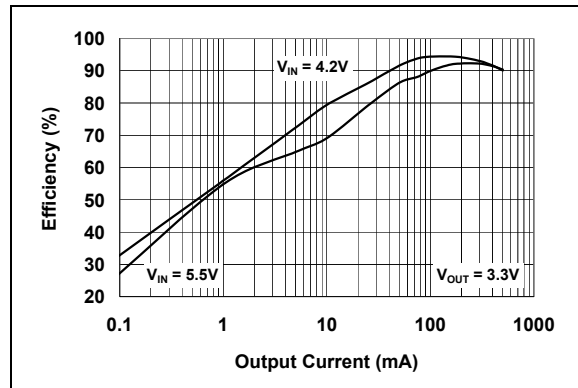

FIGURE 2-10: Efficiency vs. Output Load ($V_{OUT} = 3.3\text{V}$).

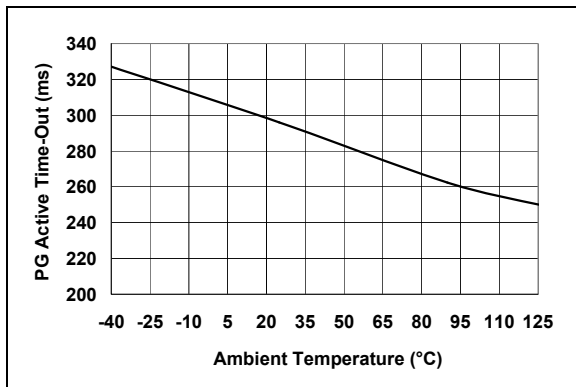

FIGURE 2-8: PG Active Time-out vs. Ambient Temperature.

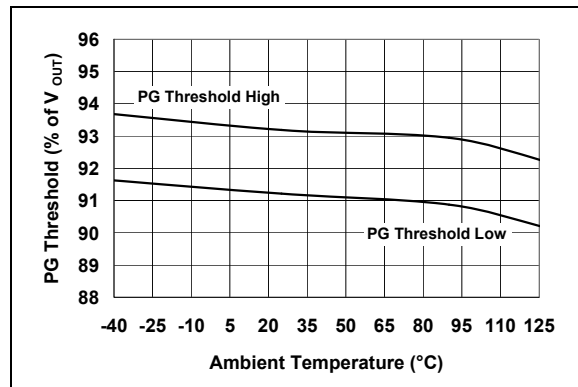

FIGURE 2-11: PG Threshold Voltage vs. Ambient Temperature.

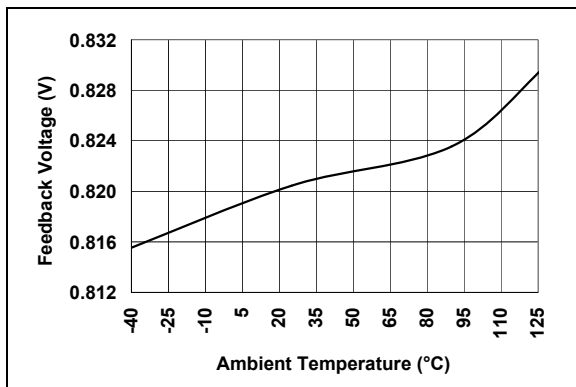

FIGURE 2-9: Feedback Voltage vs. Ambient Temperature.

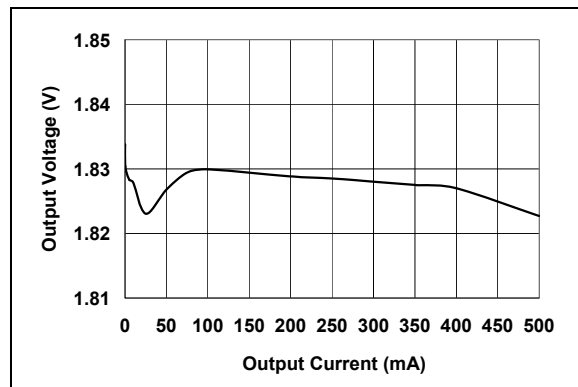

FIGURE 2-12: Output Voltage vs. Load Current ($V_{OUT} = 1.8\text{V}$).

Typical Performance Curves (Continued)

Note: Unless otherwise indicated, $V_{IN} = \overline{\text{SHDN}} = 3.6\text{V}$, $C_{OUT} = C_{IN} = 4.7\ \mu\text{F}$, $L = 4.7\ \mu\text{H}$, $V_{OUT}(\text{ADJ}) = 1.8\text{V}$, $I_{LOAD} = 100\ \text{mA}$, $T_A = +25^\circ\text{C}$. Adjustable or fixed output voltage options can be used to generate the Typical Performance Characteristics.

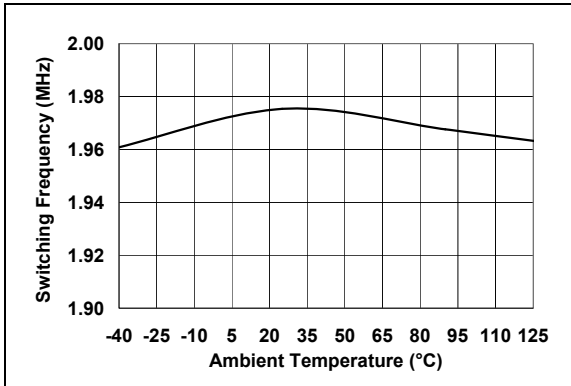

FIGURE 2-13: Switching Frequency vs. Ambient Temperature.

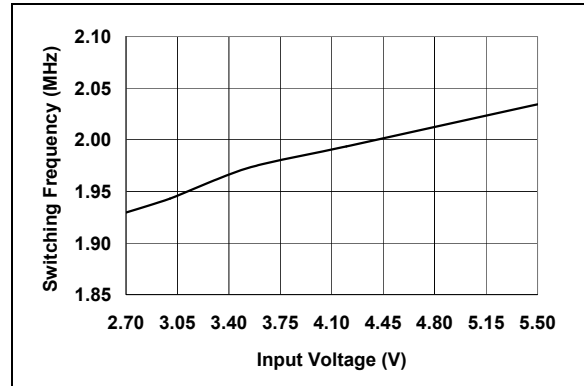

FIGURE 2-16: Switching Frequency vs. Input Voltage.

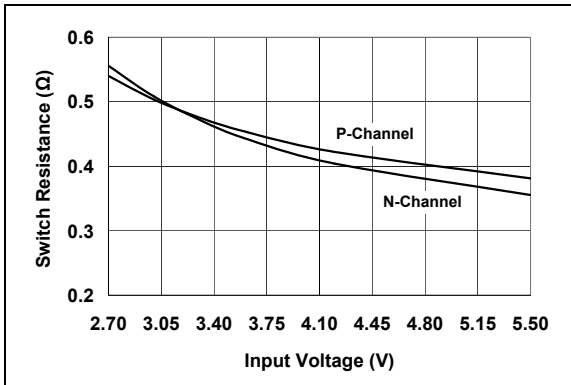

FIGURE 2-14: Switch Resistance vs. Input Voltage.

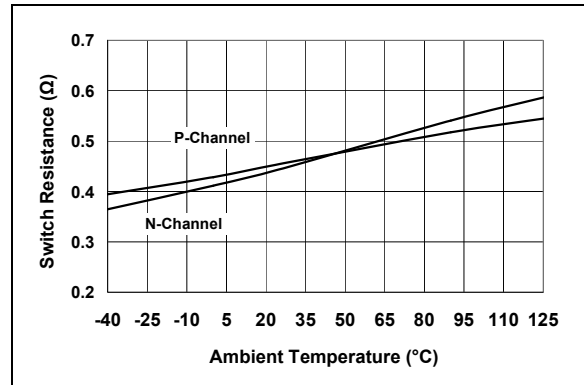

FIGURE 2-17: Switch Resistance vs. Ambient Temperature.

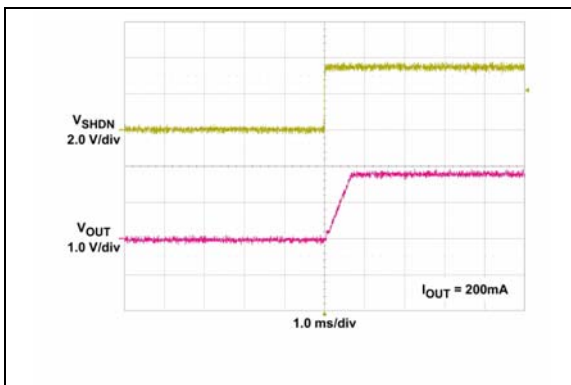

FIGURE 2-15: Output Voltage Startup Waveform.

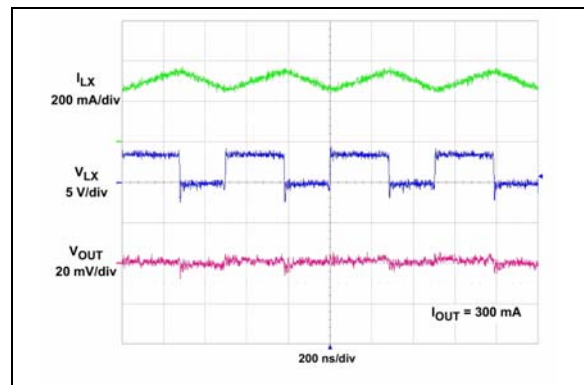

FIGURE 2-18: Heavy Load Switching Waveform.

MCP1602

Typical Performance Curves (Continued)

Note: Unless otherwise indicated, $V_{IN} = \overline{\text{SHDN}} = 3.6\text{V}$, $C_{OUT} = C_{IN} = 4.7\ \mu\text{F}$, $L = 4.7\ \mu\text{H}$, $V_{OUT(\text{ADJ})} = 1.8\text{V}$, $I_{\text{LOAD}} = 100\ \text{mA}$, $T_A = +25^\circ\text{C}$. Adjustable or fixed output voltage options can be used to generate the Typical Performance Characteristics.

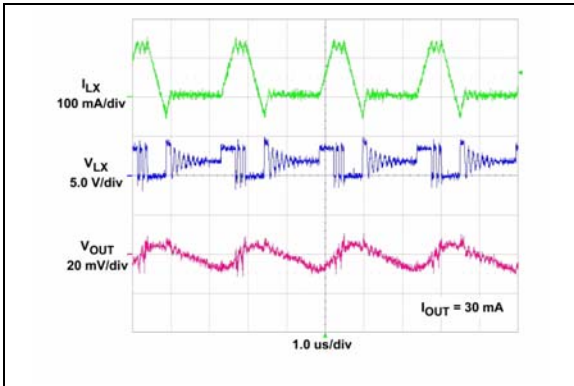

FIGURE 2-19: Light Load Switching Waveform.

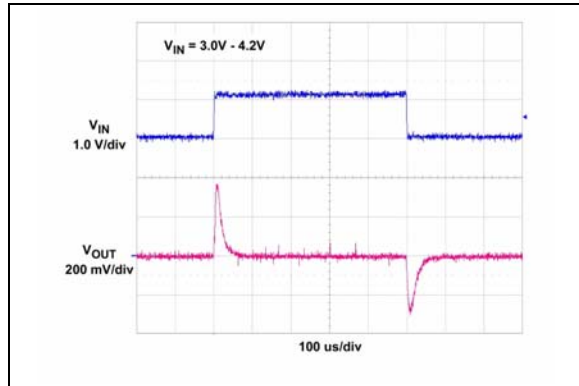

FIGURE 2-21: Output Voltage Line Step Response vs. Time.

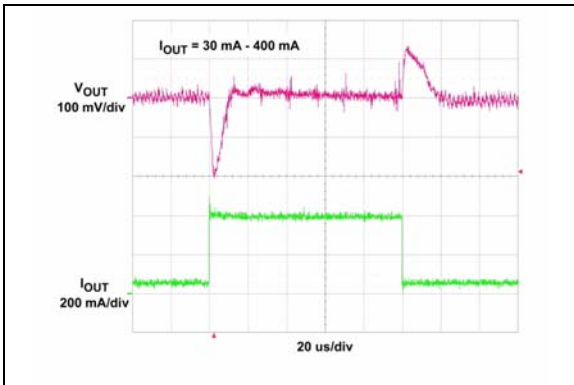

FIGURE 2-20: Output Voltage Load Step Response vs. Time.

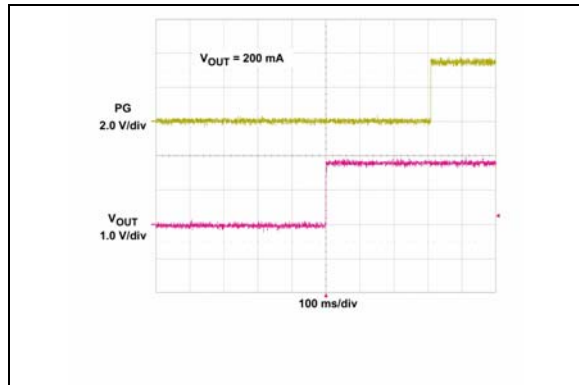

FIGURE 2-22: Power-Good Output Timing.

3.0 PIN DESCRIPTIONS

The descriptions of the pins are listed in [Table 3-1](#).

TABLE 3-1: PIN FUNCTION TABLE

MSOP	DFN	Sym	Description
1	1	$\overline{\text{SHDN}}$	Shutdown Input Pin
2	2	V_{CC}	Analog Input Supply Voltage Pin
3	3	PG	Power Good Output Pin
4	4	A_{GND}	Analog Ground Pin
5	5	$V_{\text{FB}}/V_{\text{OUT}}$	Feedback Voltage (Adjustable Version) / Output Voltage (Fixed Version) Pin
6	6	V_{IN}	Input Supply Voltage Pin
7	7	L_{X}	Buck Inductor Output Pin
8	8	P_{GND}	Power Ground Pin
—	Exposed Pad	EP	For the DFN package, the center exposed pad is a thermal path to remove heat from the device. Electrically this pad is at ground potential and should be connected to A_{GND}

3.1 Shutdown Control Input Pin ($\overline{\text{SHDN}}$)

The $\overline{\text{SHDN}}$ pin is a logic-level input used to enable or disable the device. A logic high (>45% of V_{IN}) will enable the regulator output. A logic-low (<15% of V_{IN}) will ensure that the regulator is disabled.

3.2 Analog Input Supply Voltage Pin (V_{CC})

The V_{CC} pin provides bias for internal analog functions. This voltage is derived by filtering the V_{IN} supply.

3.3 Power-Good Output Pin (PG)

PG is an output level indicating that the output voltage is within 94% of regulation. The PG output is configured as an open-drain output.

3.4 Analog Ground Pin (A_{GND})

A_{GND} is the analog ground connection. Tie A_{GND} to the analog portion of the ground plane (A_{GND}). See the physical layout information in the **Section 5.8 “PCB Layout Information”** section for ground recommendations.

3.5 Output Voltage Sense Pin ($V_{\text{FB}}/V_{\text{OUT}}$)

For the adjustable output voltage options, connect the center of the output voltage divider to the V_{FB} pin. For fixed-output voltage options, connect the output of the buck regulator to this pin (V_{OUT}).

3.6 Power Supply Input Voltage Pin (V_{IN})

V_{IN} is the buck regulator power input supply pin. Connect a variable input voltage source to V_{IN} .

3.7 Buck Inductor Output Pin (L_{X})

Connect L_{X} directly to the buck inductor. This pin carries large signal-level current; all connections should be made as short as possible.

3.8 Power Ground Pin (P_{GND})

Connect all large signal level ground returns to P_{GND} . These large signal level ground traces should have a small loop area and length to prevent coupling of switching noise to sensitive traces.

3.9 Exposed Metal Pad (EP)

For the DFN package, connect the Exposed Pad to A_{GND} , with vias into the A_{GND} plane. This connection to the A_{GND} plane will aid in heat removal from the package.

MCP1602

4.0 DETAILED DESCRIPTION

4.1 Device Overview

The MCP1602 is a synchronous buck regulator with a power-good signal. The device operates in a Pulse Frequency Modulation (PFM) mode or a Pulse Width Modulation (PWM) mode to maximize system efficiency over the entire operating current range. Capable of operating from a 2.7V to 5.5V input voltage source, the MCP1602 can deliver 500 mA of continuous output current.

When using the MCP1602, the PCB area required for a complete step-down converter is minimized since both the main P-Channel MOSFET and the synchronous N-Channel MOSFET are integrated. Also while in PWM mode, the device switches at a constant frequency of 2.0 MHz (typical) which allow for small filtering components. Both fixed and adjustable output voltage options are available. The fixed voltage options (1.2V, 1.5V, 1.8V, 2.5V, 3.3V) do not require an external voltage divider which further reduces the required circuit board footprint. The adjustable output voltage options allow for more flexibility in the design, but require an external voltage divider.

Additionally the device features undervoltage lockout (UVLO), overtemperature shutdown, overcurrent protection, and enable/disable control.

4.2 Synchronous Buck Regulator

The MCP1602 has two distinct modes of operation that allow the device to maintain a high level of efficiency throughout the entire operating current and voltage range. The device automatically switches between PWM mode and PFM mode depending upon the output load requirements.

4.2.1 FIXED FREQUENCY, PWM MODE

During heavy load conditions, the MCP1602 operates at a high, fixed switching frequency of 2.0 MHz (typical). This minimizes output ripple (10 - 15 mV typically) and noise while maintaining high efficiency (88% typical with $V_{IN} = 3.6V$, $V_{OUT} = 1.8V$, $I_{OUT} = 300\text{ mA}$).

During normal PWM operation, the beginning of a switching cycle occurs when the internal P-Channel MOSFET is turned on. The ramping inductor current is sensed and tied to one input of the internal high-speed comparator. The other input to the high-speed comparator is the error amplifier output. This is the difference between the internal 0.8V reference and the sensed output voltage. When the sensed current becomes equal to the amplified error signal, the high-speed comparator switches states and the P-Channel MOSFET is turned off. The N-Channel MOSFET is turned on until the internal oscillator sets an internal RS latch initiating the beginning of another switching cycle.

PFM-to-PWM mode transition is initiated for any of the following conditions:

- Continuous device switching
- Output voltage has dropped out of regulation

4.2.2 LIGHT LOAD, PFM MODE

During light load conditions, the MCP1602 operates in a PFM mode. When the MCP1602 enters this mode, it begins to skip pulses to minimize unnecessary quiescent current draw by reducing the number of switching cycles per second. The typical quiescent current draw for this device is 45 μA .

PWM-to-PFM mode transition is initiated for any of the following conditions:

- Discontinuous inductor current is sensed for a set duration
- Inductor peak current falls below the transition threshold limit

4.3 Power-Good (PG)

The open-drain power-good (PG) circuitry monitors the regulated output voltage. A fixed delay time of approximately 262 ms is generated once the output voltage is above the power-good high threshold, V_{TH_H} , (typically 94% of V_{OUT}). As the output voltage falls below the power-good low threshold, V_{TH_L} , (typically 92% of V_{OUT}) the PG signal transitions to a low state indicating that the output is out of regulation.

The PG circuitry has a typical 165 μs delay when detecting a falling output voltage. This helps to increase the noise immunity of the power-good output, avoiding false triggering of the PG signal during line and load transients.

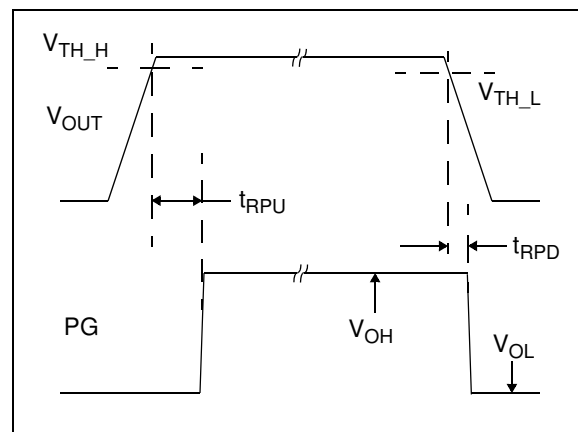

FIGURE 4-1: Power-Good Timing.

4.4 Soft Start

The output of the MCP1602 is controlled during start-up. This control allows for a very minimal amount of V_{OUT} overshoot during start-up from V_{IN} rising above the UVLO voltage or \overline{SHDN} being enabled.

4.5 Overtemperature Protection

Overtemperature protection circuitry is integrated in the MCP1602. This circuitry monitors the device junction temperature and shuts the device off if the junction temperature exceeds the typical 150°C threshold. If this threshold is exceeded, the device will automatically restart once the junction temperature drops by approximately 10°C. The soft start is reset during an overtemperature condition.

4.6 Overcurrent Protection

Cycle-by-cycle current limiting is used to protect the MCP1602 from being damaged when an external short circuit is applied. The typical peak current limit is 700 mA. If the sensed current reaches the 700 mA limit, the P-Channel MOSFET is turned off, even if the output voltage is not in regulation. The device will attempt to start a new switching cycle when the internal oscillator sets the internal RS latch.

4.7 Enable/Disable Control

The \overline{SHDN} pin is used to enable or disable the MCP1602. When the \overline{SHDN} pin is pulled low, the device is disabled. When pulled high the device is enabled and begins operation provided the input voltage is not below the UVLO threshold or a fault condition exists.

4.8 Undervoltage Lockout (UVLO)

The UVLO feature uses a comparator to sense the input voltage (V_{IN}) level. If the input voltage is lower than the voltage necessary to properly operate the MCP1602, the UVLO feature will hold the converter off. When V_{IN} rises above the necessary input voltage, the UVLO is released and soft start begins. Hysteresis is built into the UVLO circuit to compensate for input impedance. For example, if there is any resistance between the input voltage source and the device when it is operating, there will be a voltage drop at the input to the device equal to $I_{IN} \times R_{IN}$. The typical hysteresis is 200 mV.

MCP1602

5.0 APPLICATION INFORMATION

5.1 Typical Applications

The MCP1602 synchronous buck regulator with power-good operates over a wide input voltage range (2.7V to 5.5V) and is ideal for single-cell Li-Ion battery powered applications, USB powered applications, three cell NiMH or NiCd applications and 3V to 5V regulated input applications.

5.2 Fixed Output Voltage Applications

The **Typical Application Circuit** shows a fixed MCP1602 in a typical application used to convert three NiMH batteries into a well regulated 1.5V @ 500 mA output. A 4.7 μF input and output capacitor, a 4.7 μH inductor, and a small RC filter make up the entire external component selection for this application. No external voltage divider or compensation is necessary. In addition to the fixed 1.5V option, the MCP1602 is also available in 1.2V, 1.8V, 2.5V, or 3.3V fixed voltage options.

5.3 Adjustable Output Voltage Applications

When the desired output for a particular application is not covered by the fixed voltage options, an adjustable MCP1602 can be used. The circuit listed in [Figure 6-2](#) shows an adjustable MCP1602 being used to convert a 5V rail to 1.0V @ 500 mA. The output voltage is adjustable by using two external resistors as a voltage divider. For adjustable output voltages, it is recommended that the top resistor divider value be 200 kΩ. The bottom resistor value can be calculated using the following equation.

EQUATION 5-1:

$$R_{BOT} = R_{TOP} \times \left(\frac{V_{FB}}{V_{OUT} - V_{FB}} \right)$$

Example:

R_{TOP}	=	200 kΩ
V_{OUT}	=	1.0V
V_{FB}	=	0.8V
R_{BOT}	=	200 kΩ x (0.8V/(1.0V - 0.8V))
R_{BOT}	=	800 kΩ (Standard Value = 787 kΩ)

For adjustable output applications, an additional R-C compensation network is necessary for control loop stability. Recommended values for any output voltage are:

$$R_{COMP} = 4.99 \text{ k}\Omega$$

$$C_{COMP} = 33 \text{ pF}$$

Refer to [Figure 6-2](#) for proper placement of R_{COMP} and C_{COMP} .

5.4 Input Capacitor Selection

The input current to a buck converter, when operating in continuous conduction mode, is a squarewave with a duty cycle defined by the output voltage (V_{OUT}) to input voltage (V_{IN}) relationship of V_{OUT}/V_{IN} . To prevent undesirable input voltage transients, the input capacitor should be a low ESR type with a RMS current rating given by [Equation 5-2](#). Because of their small size and low ESR, ceramic capacitors are often used. Ceramic material X5R or X7R are well suited since they have a low temperature coefficient and acceptable ESR.

EQUATION 5-2:

$$I_{CIN,RMS} = I_{OUT,MAX} \times \left(\sqrt{\frac{V_{OUT} \times (V_{IN} - V_{OUT})}{V_{IN}}} \right)$$

[Table 5-1](#) contains the recommend range for the input capacitor value.

5.5 Output Capacitor Selection

The output capacitor helps provide a stable output voltage during sudden load transients, smooths the current that flows from the inductor to the load, and it also reduces the output voltage ripple. Therefore, low ESR capacitors are a desirable choice for the output capacitor. As with the input capacitor, X5R and X7R ceramic capacitors are well suited for this application.

The output ripple voltage is often a design specification. A buck converters' output ripple voltage is a function of the charging and discharging of the output capacitor and the ESR of the capacitor. This ripple voltage can be calculated by [Equation 5-3](#).

EQUATION 5-3:

$$\Delta V_{OUT} = \Delta I_L \times ESR + \frac{\Delta I_L}{8 \times f \times C}$$

Table 5-1 contains the recommend range for the output capacitor value.

TABLE 5-1: CAPACITOR VALUE RANGE

	C _{IN}	C _{OUT}
Minimum	4.7 μF	4.7 μF
Maximum	—	22 μF

5.6 Inductor Selection

For most applications an inductor value of 4.7 μH is recommended to achieve a good balance between converter load transient response and minimized noise. There are many different magnetic core materials and package options to select from. That decision is based on size, cost, and acceptable radiated energy levels. Toroid and shielded ferrite pot cores will have low radiated energy, but tend to be larger and higher in cost.

The value of inductance is selected to achieve a desired amount of ripple current. It is reasonable to assume a ripple current that is 20% of the maximum load current. The larger the amount of ripple current allowed, the larger the output capacitor value becomes to meet ripple voltage specifications. The inductor ripple current can be calculated according to Equation 5-4.

EQUATION 5-4:

$$\Delta I_L = \frac{V_{OUT}}{F_{SW} \times L} \times \left(1 - \frac{V_{OUT}}{V_{IN}}\right)$$

Where:
 F_{SW} = Switching Frequency

When considering inductor ratings, the maximum DC current rating of the inductor should be at least equal to the maximum load current, plus one half the peak-to-peak inductor ripple current (1/2 * ΔI_L). The inductor DC resistance adds to the total converter power loss. An inductor with a low DC resistance allows for higher converter efficiency.

TABLE 5-2: MCP1602 RECOMMENDED INDUCTORS

Part Number	Value (μH)	DCR Ω (max)	I _{SAT} (A)	Size WxLxH (mm)
Coiltronics®				
SD10	3.3	0.108	1.31	5.2x5.2x1.0
SD10	4.7	0.154	1.08	5.2x5.2x1.0
SD10	6.2	0.218	0.92	5.2x5.2x1.0
SD12	3.3	0.104	1.42	5.2x5.2x1.2
SD12	4.7	0.118	1.29	5.2x5.2x1.2
SD12	6.2	0.170	1.08	5.2x5.2x1.2

TABLE 5-2: MCP1602 RECOMMENDED INDUCTORS (CONTINUED)

Part Number	Value (μH)	DCR Ω (max)	I _{SAT} (A)	Size WxLxH (mm)
Würth Elektronik®				
WE-TPC Type S	3.6	0.085	1.10	3.8x3.8x1.65
WE-TPC Type S	4.7	0.105	0.90	3.8x3.8x1.65
WE-TPC Type S	6.8	0.156	0.75	3.8x3.8x1.65
WE-TPC Type M	3.3	0.065	1.80	4.8x4.8x1.8
WE-TPC Type M	4.7	0.082	1.65	4.8x4.8x1.8
WE-TPC Type M	6.8	0.100	1.25	4.8x4.8x1.8

5.7 Thermal Calculations

The MCP1602 is available in two different packages (MSOP and 3x3 DFN). By calculating the power dissipation and applying the package thermal resistance, (θ_{JA}), the junction temperature is estimated. The maximum continuous junction temperature rating for the MCP1602 is +125°C.

To quickly estimate the internal power dissipation for the switching buck regulator, an empirical calculation using measured efficiency can be used. Given the measured efficiency, the internal power dissipation is estimated by:

EQUATION 5-5:

$$\left(\frac{V_{OUT} \times I_{OUT}}{Efficiency}\right) - (V_{OUT} \times I_{OUT}) = P_{Dis}$$

The difference between the first term, input power dissipation, and the second term, power delivered, is the internal power dissipation. This is an estimate assuming that most of the power lost is internal to the MCP1602. There is some percentage of power lost in the buck inductor, with very little loss in the input and output capacitors.

MCP1602

5.8 PCB Layout Information

Good printed circuit board layout techniques are important to any switching circuitry and switching power supplies are no different. When wiring the high current paths, short and wide traces should be used. This high current path is shown with red connections in Figure 5-1. Therefore, it is important that the

components along the high current path should be placed as close as possible to the MCP1602 to minimize the loop area.

The feedback resistors and feedback signal should be routed away from the switching node and this switching current loop. When possible ground planes and traces should be used to help shield the feedback signal and minimize noise and magnetic interference.

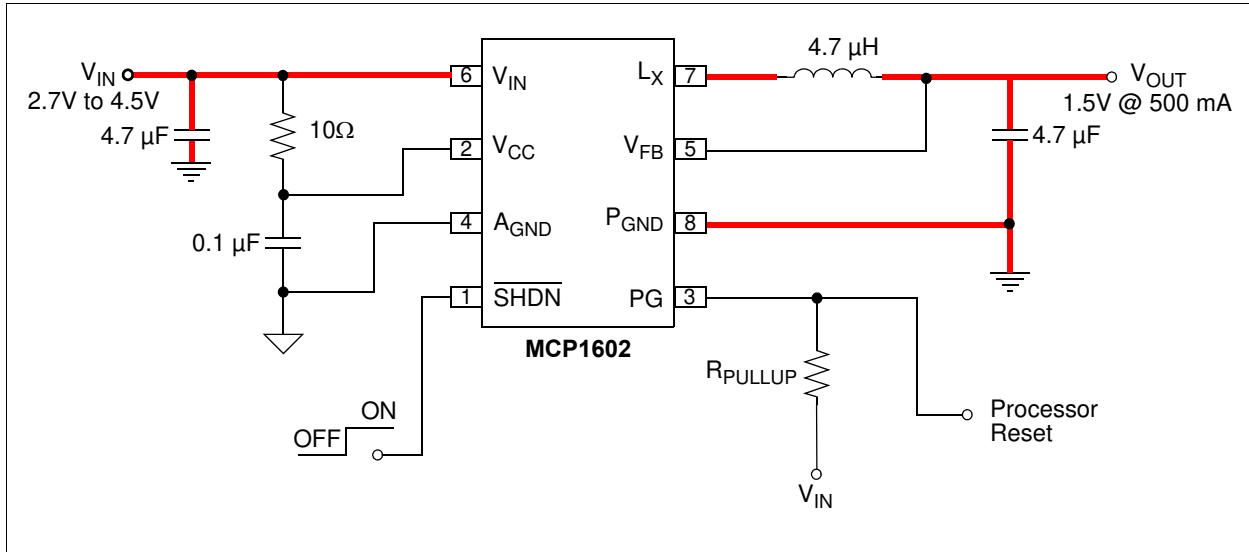

FIGURE 5-1: PCB High Current Path.

6.0 TYPICAL APPLICATION CIRCUITS

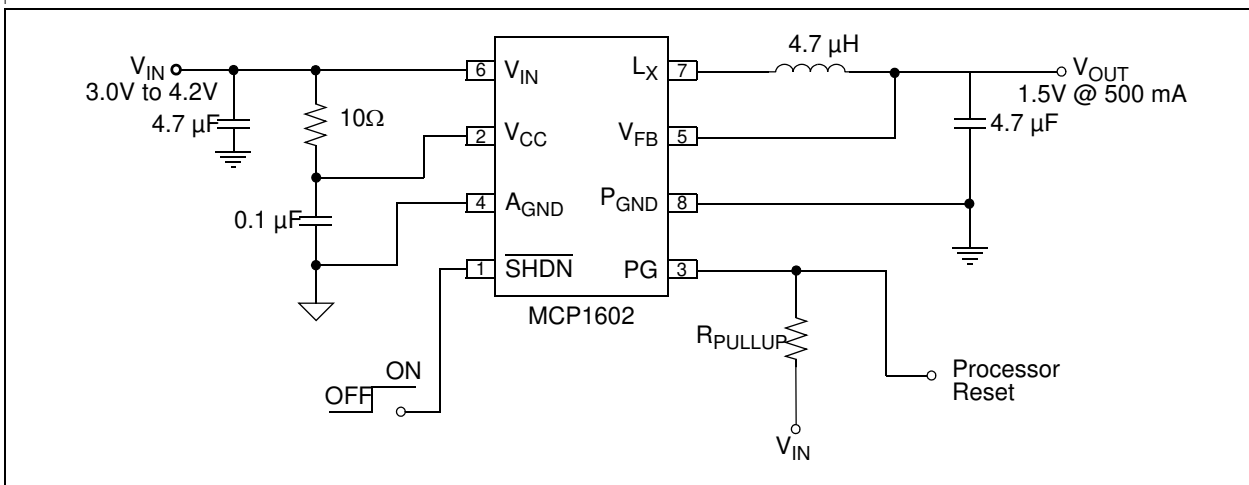

FIGURE 6-1: Single Li-Ion to 1.5V @ 500 mA Application.

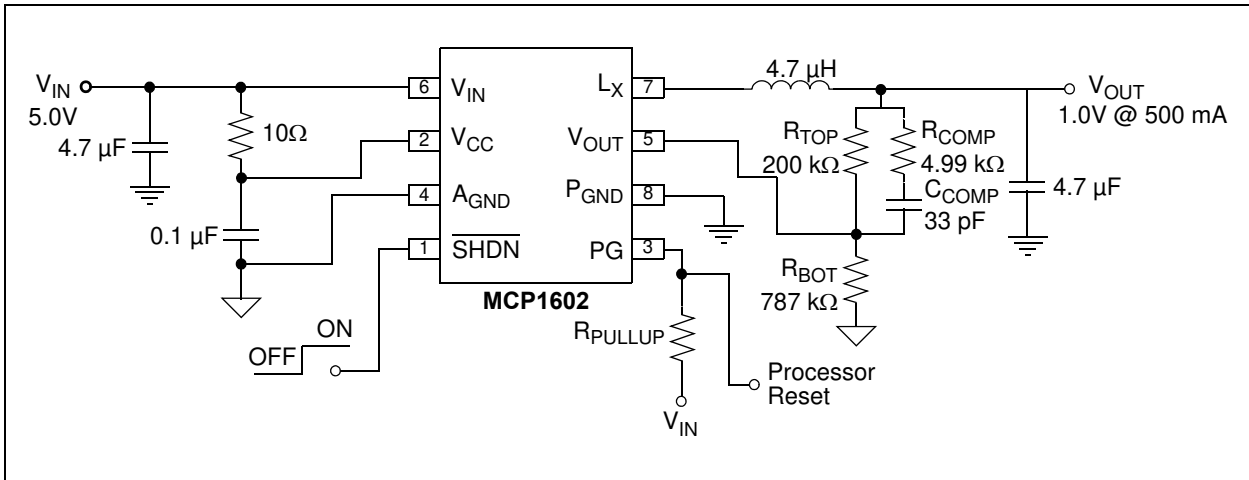

FIGURE 6-2: 5V to 1.0V @ 500 mA Application.

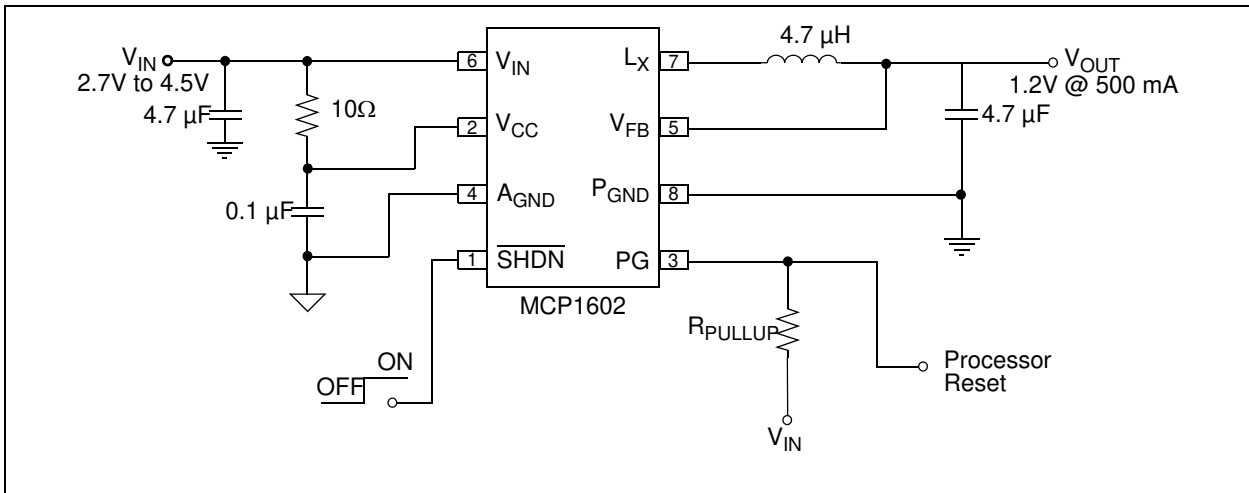

FIGURE 6-3: 3 NiMH Batteries to 1.2V @ 500 mA Application.

MCP1602

7.0 PACKAGING INFORMATION

7.1 Package Marking Information

8-Lead DFN (3x3)

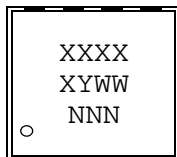

Part Number	Code
MCP1602-120I/MF	CAAU
MCP1602-150I/MF	CAAV
MCP1602-180I/MF	CAAW
MCP1602-250I/MF	CAAY
MCP1602-330I/MF	CAAZ
MCP1602-ADJI/MF	CAAS

Example:

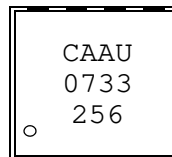

8-Lead MSOP

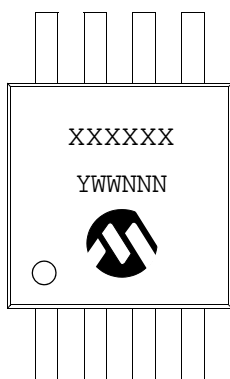

Part Number	Code
MCP1602-120I/MF	160212
MCP1602-150I/MF	160215
MCP1602-180I/MF	160218
MCP1602-250I/MF	160225
MCP1602-330I/MF	160233
MCP1602-ADJI/MF	1602AJ

Example:

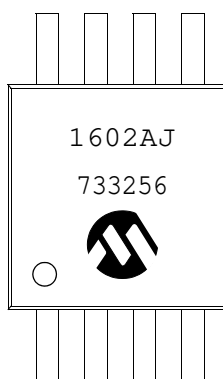

Legend:	XX...X	Customer-specific information
	Y	Year code (last digit of calendar year)
	YY	Year code (last 2 digits of calendar year)
	WW	Week code (week of January 1 is week '01')
	NNN	Alphanumeric traceability code
	(e3)	Pb-free JEDEC designator for Matte Tin (Sn)
	*	This package is Pb-free. The Pb-free JEDEC designator (e3) can be found on the outer packaging for this package.

Note: In the event the full Microchip part number cannot be marked on one line, it will be carried over to the next line, thus limiting the number of available characters for customer-specific information.

8-Lead Plastic Dual Flat, No Lead Package (MF) – 3x3x0.9 mm Body [DFN]

Note: For the most current package drawings, please see the Microchip Packaging Specification located at <http://www.microchip.com/packaging>

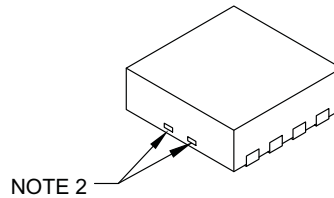
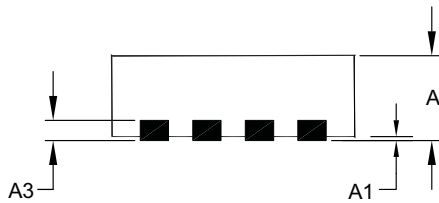
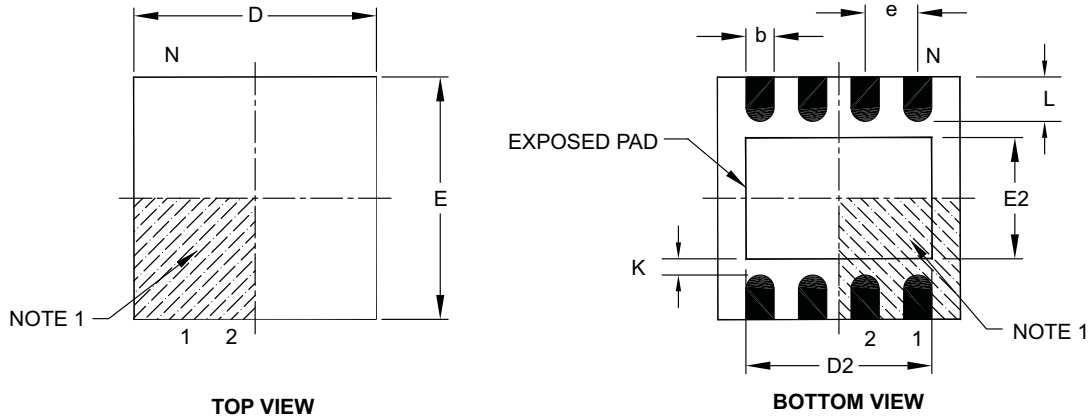

Dimension Limits	Units	MILLIMETERS		
		MIN	NOM	MAX
Number of Pins	N	8		
Pitch	e	0.65 BSC		
Overall Height	A	0.80	0.90	1.00
Standoff	A1	0.00	0.02	0.05
Contact Thickness	A3	0.20 REF		
Overall Length	D	3.00 BSC		
Exposed Pad Width	E2	0.00	–	1.60
Overall Width	E	3.00 BSC		
Exposed Pad Length	D2	0.00	–	2.40
Contact Width	b	0.25	0.30	0.35
Contact Length	L	0.20	0.30	0.55
Contact-to-Exposed Pad	K	0.20	–	–

Notes:

- Pin 1 visual index feature may vary, but must be located within the hatched area.
- Package may have one or more exposed tie bars at ends.
- Package is saw singulated.
- Dimensioning and tolerancing per ASME Y14.5M.

BSC: Basic Dimension. Theoretically exact value shown without tolerances.

REF: Reference Dimension, usually without tolerance, for information purposes only.

Microchip Technology Drawing C04-062B

MCP1602

8-Lead Plastic Micro Small Outline Package (MS) [MSOP]

Note: For the most current package drawings, please see the Microchip Packaging Specification located at <http://www.microchip.com/packaging>

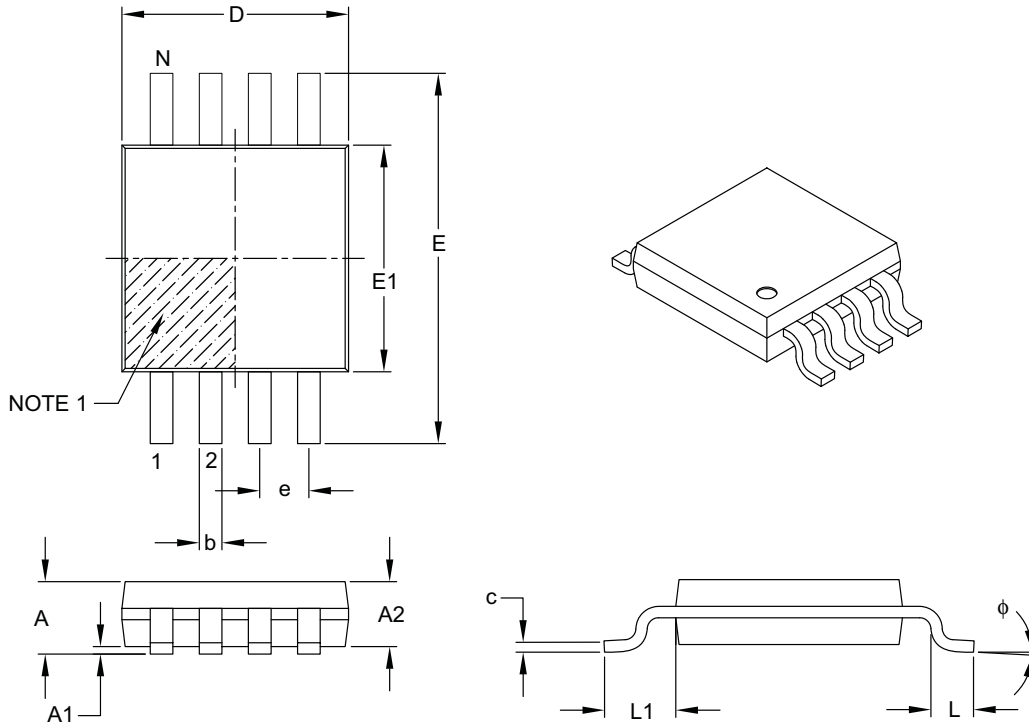

Dimension Limits	Units	MILLIMETERS		
		MIN	NOM	MAX
Number of Pins	N	8		
Pitch	e	0.65 BSC		
Overall Height	A	–	–	1.10
Molded Package Thickness	A2	0.75	0.85	0.95
Standoff	A1	0.00	–	0.15
Overall Width	E	4.90 BSC		
Molded Package Width	E1	3.00 BSC		
Overall Length	D	3.00 BSC		
Foot Length	L	0.40	0.60	0.80
Footprint	L1	0.95 REF		
Foot Angle	ϕ	0°	–	8°
Lead Thickness	c	0.08	–	0.23
Lead Width	b	0.22	–	0.40

Notes:

- Pin 1 visual index feature may vary, but must be located within the hatched area.
- Dimensions D and E1 do not include mold flash or protrusions. Mold flash or protrusions shall not exceed 0.15 mm per side.
- Dimensioning and tolerancing per ASME Y14.5M.

BSC: Basic Dimension. Theoretically exact value shown without tolerances.

REF: Reference Dimension, usually without tolerance, for information purposes only.

Microchip Technology Drawing C04-111B

APPENDIX A: REVISION HISTORY

Revision A (October 2007)

- Original Release of this Document.

MCP1602

NOTES:

PRODUCT IDENTIFICATION SYSTEM

To order or obtain information, e.g., on pricing or delivery, refer to the factory or the listed sales office.

<u>PART NO.</u>	<u>X</u>	<u>-XXX</u>	<u>X</u>	<u>XX</u>
Device	Tape & Reel	Voltage Output	Temp. Range	Package
Device	MCP1602: 2.0 MHz, 500 mA, Buck Reg w/Power-Good			
Tape & Reel	T = Tape and Reel Blank = Tube			
Standard Fixed Output Voltage *	120 = 1.20V 150 = 1.50V 180 = 1.80V 250 = 2.50V 330 = 3.30V ADJ = Adjustable Voltage Version (0.8V to 4.5V)			
	* Custom output voltages available upon request. Contact your local Microchip sales office for more information.			
Temperature Range	I = -40°C to +85°C			
Package *	MF = Plastic Dual Flat No Lead, (3x3 mm Body), 8-Lead MS = Plastic Micro Small Outline, 8-Lead			
Examples:				
a)	MCP1602-1202I/MF:	1.20V, 500 mA	Buck Reg, 8LD DFN Pkg.	
b)	MCP1602-1202I/MS:	1.20V, 500 mA	Buck Reg, 8LD MSOP Pkg.	
c)	MCP1602-1502I/MF:	1.50V, 500 mA	Buck Reg, 8LD DFN Pkg.	
d)	MCP1602-1502I/MS:	1.50V, 500 mA	Buck Reg, 8LD MSOP Pkg.	
e)	MCP1602-1802I/MF:	1.80V, 500 mA	Buck Reg, 8LD DFN Pkg.	
f)	MCP1602-1802I/MS:	1.80V, 500 mA	Buck Reg, 8LD MSOP Pkg.	
g)	MCP1602-2502I/MF:	2.50V, 500 mA	Buck Reg, 8LD DFN Pkg.	
h)	MCP1602-2502I/MS:	2.50V, 500 mA	Buck Reg, 8LD MSOP Pkg.	
i)	MCP1602T-3302I/MF:	Tape and Reel, 3.30V, 500 mA	Buck Reg, 8LD DFN Pkg.	
j)	MCP1602-3302I/MS:	3.30V, 500 mA	Buck Reg, 8LD MSOP Pkg.	
k)	MCP1602-ADJI/MF:	Adjustable, 500 mA	Buck Reg, 8LD DFN Pkg.	
l)	MCP1602-ADJI/MS:	Adjustable, 500 mA	Buck Reg, 8LD MSOP Pkg.	

MCP1602

NOTES:

Note the following details of the code protection feature on Microchip devices:

- Microchip products meet the specification contained in their particular Microchip Data Sheet.
- Microchip believes that its family of products is one of the most secure families of its kind on the market today, when used in the intended manner and under normal conditions.
- There are dishonest and possibly illegal methods used to breach the code protection feature. All of these methods, to our knowledge, require using the Microchip products in a manner outside the operating specifications contained in Microchip's Data Sheets. Most likely, the person doing so is engaged in theft of intellectual property.
- Microchip is willing to work with the customer who is concerned about the integrity of their code.
- Neither Microchip nor any other semiconductor manufacturer can guarantee the security of their code. Code protection does not mean that we are guaranteeing the product as “unbreakable.”

Code protection is constantly evolving. We at Microchip are committed to continuously improving the code protection features of our products. Attempts to break Microchip's code protection feature may be a violation of the Digital Millennium Copyright Act. If such acts allow unauthorized access to your software or other copyrighted work, you may have a right to sue for relief under that Act.

Information contained in this publication regarding device applications and the like is provided only for your convenience and may be superseded by updates. It is your responsibility to ensure that your application meets with your specifications. MICROCHIP MAKES NO REPRESENTATIONS OR WARRANTIES OF ANY KIND WHETHER EXPRESS OR IMPLIED, WRITTEN OR ORAL, STATUTORY OR OTHERWISE, RELATED TO THE INFORMATION, INCLUDING BUT NOT LIMITED TO ITS CONDITION, QUALITY, PERFORMANCE, MERCHANTABILITY OR FITNESS FOR PURPOSE. Microchip disclaims all liability arising from this information and its use. Use of Microchip devices in life support and/or safety applications is entirely at the buyer's risk, and the buyer agrees to defend, indemnify and hold harmless Microchip from any and all damages, claims, suits, or expenses resulting from such use. No licenses are conveyed, implicitly or otherwise, under any Microchip intellectual property rights.

Trademarks

The Microchip name and logo, the Microchip logo, Accuron, dsPIC, KEELOQ, KEELOQ logo, microID, MPLAB, PIC, PICmicro, PICSTART, PRO MATE, rPIC and SmartShunt are registered trademarks of Microchip Technology Incorporated in the U.S.A. and other countries.

AmpLab, FilterLab, Linear Active Thermistor, Migratable Memory, MXDEV, MXLAB, SEEVAL, SmartSensor and The Embedded Control Solutions Company are registered trademarks of Microchip Technology Incorporated in the U.S.A.

Analog-for-the-Digital Age, Application Maestro, CodeGuard, dsPICDEM, dsPICDEM.net, dsPICworks, dsSPEAK, ECAN, ECONOMONITOR, FanSense, FlexROM, fuzzyLAB, In-Circuit Serial Programming, ICSP, ICEPIC, Mindi, MiWi, MPASM, MPLAB Certified logo, MPLIB, MPLINK, PICkit, PICDEM, PICDEM.net, PICLAB, PICtail, PowerCal, PowerInfo, PowerMate, PowerTool, REAL ICE, rLAB, Select Mode, Smart Serial, SmartTel, Total Endurance, UNI/O, WiperLock and ZENA are trademarks of Microchip Technology Incorporated in the U.S.A. and other countries.

SQTP is a service mark of Microchip Technology Incorporated in the U.S.A.

All other trademarks mentioned herein are property of their respective companies.

© 2007, Microchip Technology Incorporated, Printed in the U.S.A., All Rights Reserved.

 Printed on recycled paper.

QUALITY MANAGEMENT SYSTEM
CERTIFIED BY DNV
== ISO/TS 16949:2002 ==

Microchip received ISO/TS-16949:2002 certification for its worldwide headquarters, design and wafer fabrication facilities in Chandler and Tempe, Arizona; Gresham, Oregon and design centers in California and India. The Company's quality system processes and procedures are for its PIC® MCUs and dsPIC® DSCs, KEELOQ® code hopping devices, Serial EEPROMs, microperipherals, nonvolatile memory and analog products. In addition, Microchip's quality system for the design and manufacture of development systems is ISO 9001:2000 certified.