



Chipsmall Limited consists of a professional team with an average of over 10 year of expertise in the distribution of electronic components. Based in Hongkong, we have already established firm and mutual-benefit business relationships with customers from,Europe,America and south Asia,supplying obsolete and hard-to-find components to meet their specific needs.

With the principle of “Quality Parts,Customers Priority,Honest Operation,and Considerate Service”,our business mainly focus on the distribution of electronic components. Line cards we deal with include Microchip,ALPS,ROHM,Xilinx,Pulse,ON,Everlight and Freescale. Main products comprise IC,Modules,Potentiometer,IC Socket,Relay,Connector.Our parts cover such applications as commercial,industrial, and automotives areas.

We are looking forward to setting up business relationship with you and hope to provide you with the best service and solution. Let us make a better world for our industry!



Contact us

Tel: +86-755-8981 8866 Fax: +86-755-8427 6832

Email & Skype: info@chipsmall.com Web: www.chipsmall.com

Address: A1208, Overseas Decoration Building, #122 Zhenhua RD., Futian, Shenzhen, China



High-Voltage Input Integrated Switch Step-Down Regulator

Features

- Up to 96% Typical Efficiency
- Input Voltage Range:
 - 4.0V to 30V (**MCP16301**)
 - 4.7V to 36V (**MCP16301H**)
- Output Voltage Range: 2.0V to 15V
- 2% Output Voltage Accuracy
- Qualification: AEC-Q100 Rev G, Grade 1 (-40°C to +125°C)
- Integrated N-Channel Buck Switch: 460 mΩ
- Minimum 600 mA Output Current Over All Input Voltage Range (See [Figure 2-6](#) for Maximum Output Current vs. V_{IN}):
 - up to 1A output current at 3.3V, 5V and 12V V_{OUT} , SOT-23 package at +25°C ambient temperature
- 500 kHz Fixed Frequency
- Adjustable Output Voltage
- Low Device Shutdown Current
- Peak Current Mode Control
- Internal Compensation
- Stable with Ceramic Capacitors
- Internal Soft-Start
- Cycle-by-Cycle Peak Current Limit
- Undervoltage Lockout (UVLO): 3.5V
- Overtemperature Protection
- Available Package: SOT-23-6

Applications

- PIC[®] Microcontroller and dsPIC[®] Digital Signal Controller Bias Supply
- 24V Industrial Input DC-DC Conversion
- Set-Top Boxes
- DSL Cable Modems
- Automotive
- Wall Cube Regulation
- SLA Battery-Powered Devices
- AC-DC Digital Control Power Source
- Power Meters
- D² Package Linear Regulator Replacement
 - See [Figure 5-2](#)
- Consumer
- Medical and Health Care
- Distributed Power Supplies

General Description

The MCP16301/H devices are highly integrated, high-efficiency, fixed-frequency, step-down DC-DC converters in a popular 6-pin SOT-23 package that operates from input voltage sources up to 36V. Integrated features include a high-side switch, fixed-frequency peak current mode control, internal compensation, peak current limit and overtemperature protection. Minimal external components are necessary to develop a complete step-down DC-DC converter power supply.

High converter efficiency is achieved by integrating the current-limited, low-resistance, high-speed N-Channel MOSFET and associated drive circuitry. High switching frequency minimizes the size of external filtering components, resulting in a small solution size.

The MCP16301/H devices can supply 600 mA of continuous current while regulating the output voltage from 2.0V to 15V. An integrated, high-performance peak current mode architecture keeps the output voltage tightly regulated, even during input voltage steps and output current transient conditions that are common in power systems.

The EN input is used to turn the device on and off. While turned off, only a few micro amps of current are consumed from the input for power shedding and load distribution applications.

Output voltage is set with an external resistor divider. The MCP16301/H devices are offered in a space-saving SOT-23-6 surface mount package.

Package Type

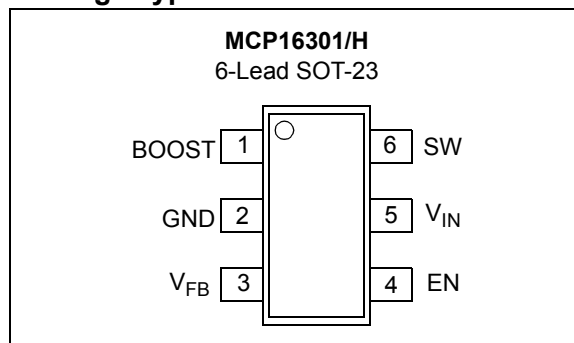

MCP16301/H

Typical Applications

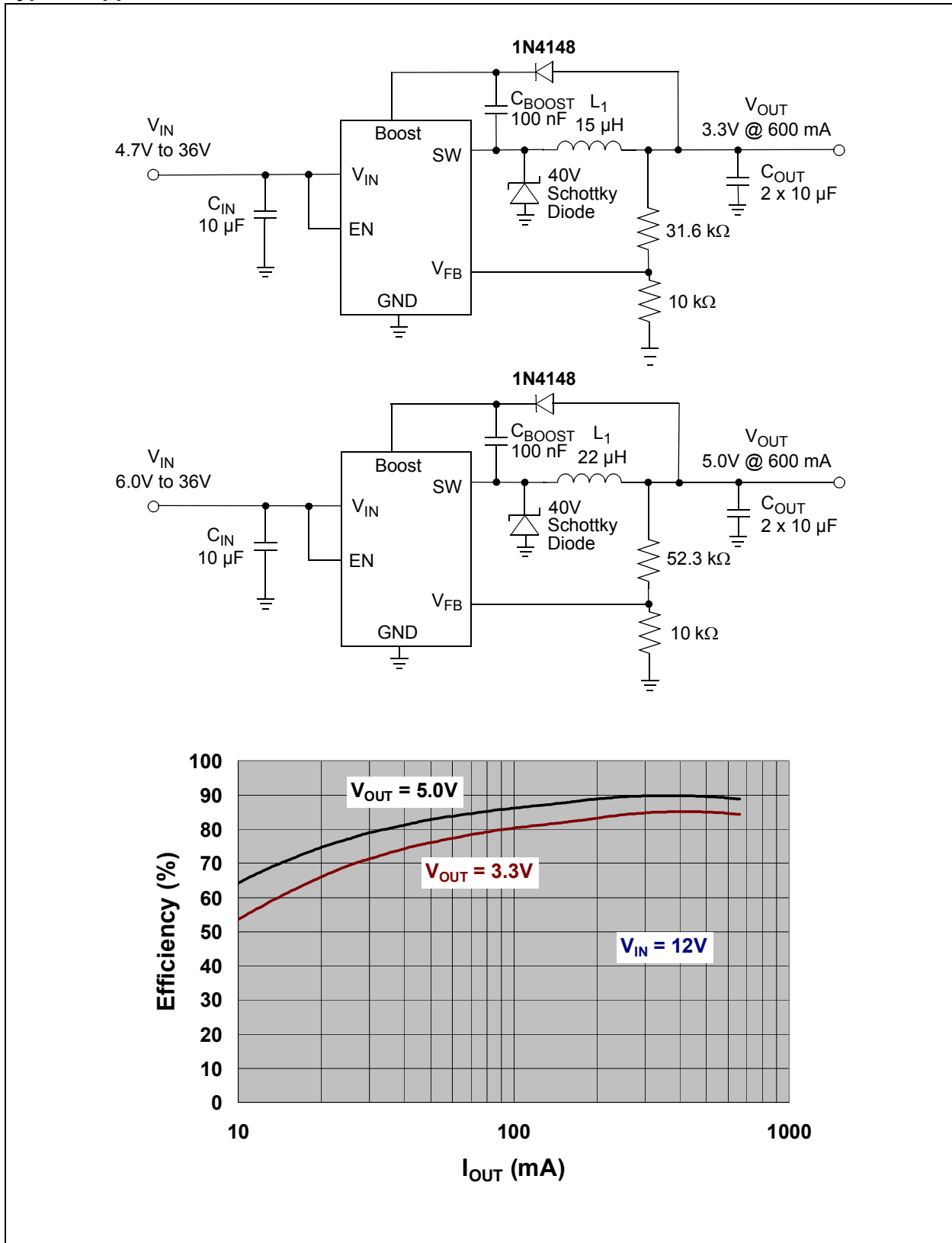

1.0 ELECTRICAL CHARACTERISTICS

Absolute Maximum Ratings †

$V_{IN, SW}$	-0.5V to 40V
BOOST – GND	-0.5V to 46V
BOOST – SW Voltage	-0.5V to 6.0V
V_{FB} Voltage	-0.5V to 6.0V
EN Voltage	-0.5V to ($V_{IN} + 0.3V$)
Output Short-Circuit Current	Continuous
Power Dissipation	Internally Limited
Storage Temperature	-65°C to +150°C
Ambient Temperature with Power Applied	-40°C to +125°C
Operating Junction Temperature	-40°C to +150°C
ESD Protection On All Pins:	
HBM	3 kV
MM	200V

† **Notice:** Stresses above those listed under “Maximum Ratings” may cause permanent damage to the device. This is a stress rating only and functional operation of the device at those or any other conditions above those indicated in the operational sections of this specification is not intended. Exposure to maximum rating conditions for extended periods may affect device reliability.

DC CHARACTERISTICS

Electrical Characteristics: Unless otherwise indicated, $T_A = +25^\circ\text{C}$, $V_{IN} = V_{EN} = 12V$, $V_{BOOST} - V_{SW} = 3.3V$, $V_{OUT} = 3.3V$, $I_{OUT} = 100\text{ mA}$, $L = 15\ \mu\text{H}$, $C_{OUT} = C_{IN} = 2 \times 10\ \mu\text{F}$ X7R ceramic capacitors.
Boldface specifications apply over the T_A range of -40°C to $+125^\circ\text{C}$.

Parameters	Sym.	Min.	Typ.	Max.	Units	Conditions
Input Voltage	V_{IN}	4	—	30	V	Note 1 (MCP16301)
		4.7	—	36	V	Note 1 (MCP16301H)
Feedback Voltage	V_{FB}	0.784	0.800	0.816	V	
Output Voltage Adjust Range	V_{OUT}	2.0	—	15.0	V	Note 2
Feedback Voltage Line Regulation	$(\Delta V_{FB}/V_{FB})/\Delta V_{IN}$	—	0.01	0.1	%/V	$V_{IN} = 12V$ to $30V$
Feedback Input Bias Current	I_{FB}	-250	± 10	+250	nA	
Undervoltage Lockout Start	$UVLO_{START}$	—	3.5	4.0	V	V_{IN} Rising (MCP16301)
		—	3.5	4.7	V	V_{IN} Rising (MCP16301H)
Undervoltage Lockout Stop	$UVLO_{STOP}$	2.4	3.0	—	V	V_{IN} Falling
Undervoltage Lockout Hysteresis	$UVLO_{HYS}$	—	0.5	—	V	
Switching Frequency	f_{SW}	425	500	550	kHz	$I_{OUT} = 200\text{ mA}$
Maximum Duty Cycle	DC_{MAX}	90	95	—	%	$V_{IN} = 5V$; $V_{FB} = 0.7V$; $I_{OUT} = 100\text{ mA}$
Minimum Duty Cycle	DC_{MIN}	—	1	—	%	
NMOS Switch On Resistance	$R_{DS(ON)}$	—	0.46	—	Ω	$V_{BOOST} - V_{SW} = 3.3V$
NMOS Switch Current Limit	$I_{N(MAX)}$	—	1.3	—	A	$V_{BOOST} - V_{SW} = 3.3V$
Quiescent Current	I_Q	—	2	7.5	mA	$V_{BOOST} = 3.3V$; Note 3
Quiescent Current - Shutdown	I_Q	—	7	10	μA	$V_{OUT} = EN = 0V$
Maximum Output Current	I_{OUT}	600	—	—	mA	Note 1
EN Input Logic High	V_{IH}	1.4	—	—	V	
EN Input Logic Low	V_{IL}	—	—	0.4	V	
EN Input Leakage Current	I_{ENLK}	—	0.05	1.0	μA	$V_{EN} = 12V$

Note 1: The input voltage should be $>$ output voltage + headroom voltage; higher load currents increase the input voltage necessary for regulation. See characterization graphs for typical input to output operating voltage range and $UVLO_{START}$ and $UVLO_{STOP}$ limits.

2: For $V_{IN} < V_{OUT}$, V_{OUT} will not remain in regulation.

3: V_{BOOST} supply is derived from V_{OUT} .

MCP16301/H

DC CHARACTERISTICS (CONTINUED)

Electrical Characteristics: Unless otherwise indicated, $T_A = +25^\circ\text{C}$, $V_{IN} = V_{EN} = 12\text{V}$, $V_{BOOST} - V_{SW} = 3.3\text{V}$, $V_{OUT} = 3.3\text{V}$, $I_{OUT} = 100\text{ mA}$, $L = 15\ \mu\text{H}$, $C_{OUT} = C_{IN} = 2 \times 10\ \mu\text{F}$ X7R ceramic capacitors.
Boldface specifications apply over the T_A range of -40°C to $+125^\circ\text{C}$.

Parameters	Sym.	Min.	Typ.	Max.	Units	Conditions
Soft-Start Time	t_{SS}	—	300	—	μS	EN Low to High, 90% of V_{OUT}
Thermal Shutdown Die Temperature	T_{SD}	—	150	—	$^\circ\text{C}$	
Die Temperature Hysteresis	T_{SDHYS}	—	30	—	$^\circ\text{C}$	

- Note 1:** The input voltage should be $>$ output voltage + headroom voltage; higher load currents increase the input voltage necessary for regulation. See characterization graphs for typical input to output operating voltage range and $UVLO_{START}$ and $UVLO_{STOP}$ limits.
- 2:** For $V_{IN} < V_{OUT}$, V_{OUT} will not remain in regulation.
- 3:** V_{BOOST} supply is derived from V_{OUT} .

TEMPERATURE SPECIFICATIONS

Electrical Specifications: Unless otherwise indicated, $T_A = +25^\circ\text{C}$, $V_{IN} = V_{EN} = 12\text{V}$, $V_{BOOST} - V_{SW} = 3.3\text{V}$, $V_{OUT} = 3.3\text{V}$

Parameters	Sym.	Min.	Typ.	Max.	Units	Conditions
Temperature Ranges						
Operating Junction Temperature Range	T_J	-40	—	+125	$^\circ\text{C}$	Steady State
Storage Temperature Range	T_A	-65	—	+150	$^\circ\text{C}$	
Maximum Junction Temperature	T_J	—	—	+150	$^\circ\text{C}$	Transient
Package Thermal Resistances						
Thermal Resistance, 6L-SOT-23	θ_{JA}	—	190.5	—	$^\circ\text{C/W}$	EIA/JESD51-3 Standard

2.0 TYPICAL PERFORMANCE CURVES

Note: The graphs and tables provided following this note are a statistical summary based on a limited number of samples and are provided for informational purposes only. The performance characteristics listed herein are not tested or guaranteed. In some graphs or tables, the data presented may be outside the specified operating range (e.g., outside specified power supply range) and therefore outside the warranted range.

Note: Unless otherwise indicated, $V_{IN} = EN = 12V$, $C_{OUT} = C_{IN} = 2 \times 10 \mu F$, $L = 15 \mu H$, $V_{OUT} = 3.3V$, $I_{LOAD} = 200 \text{ mA}$, $T_A = +25^\circ C$.

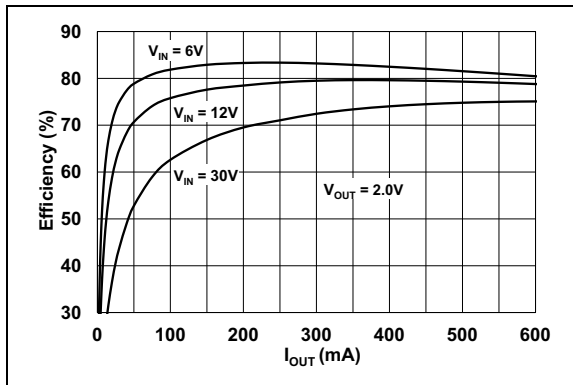

FIGURE 2-1: 2.0V V_{OUT} Efficiency vs. I_{OUT} .

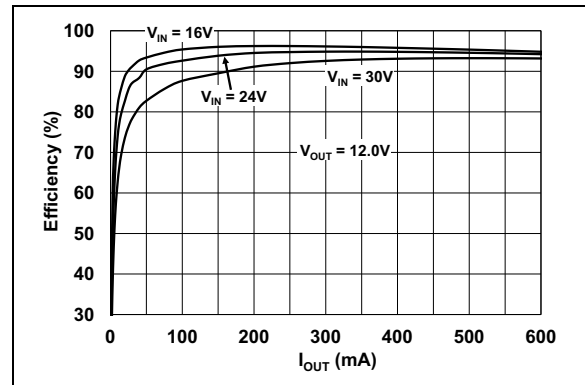

FIGURE 2-4: 12V V_{OUT} Efficiency vs. I_{OUT} .

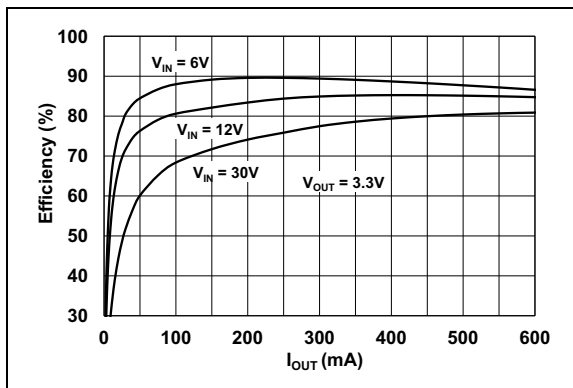

FIGURE 2-2: 3.3V V_{OUT} Efficiency vs. I_{OUT} .

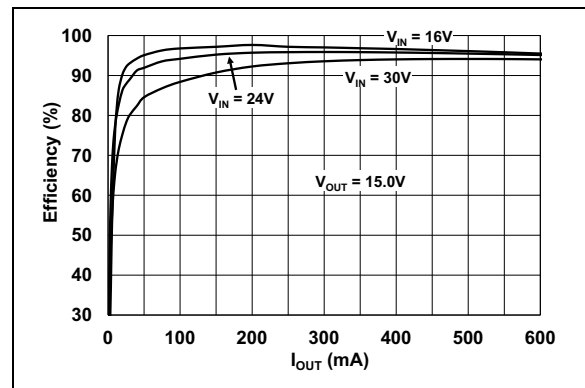

FIGURE 2-5: 15V V_{OUT} Efficiency vs. I_{OUT} .

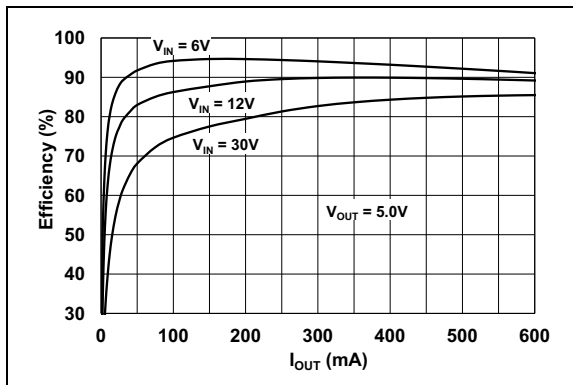

FIGURE 2-3: 5.0V V_{OUT} Efficiency vs. I_{OUT} .

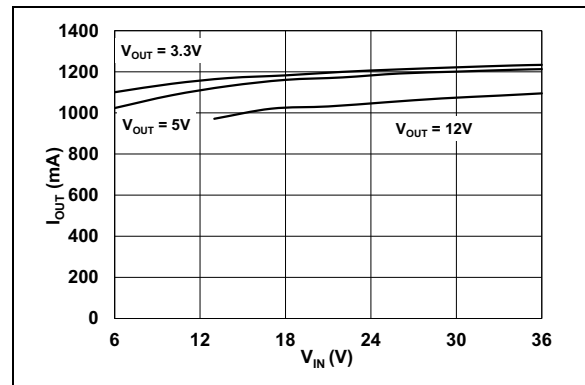

FIGURE 2-6: Maximum Output Current vs. V_{IN} .

MCP16301/H

Note: Unless otherwise indicated, $V_{IN} = EN = 12V$, $C_{OUT} = C_{IN} = 2 \times 10 \mu F$, $L = 15 \mu H$, $V_{OUT} = 3.3V$, $I_{LOAD} = 200 \text{ mA}$, $T_A = +25^\circ C$.

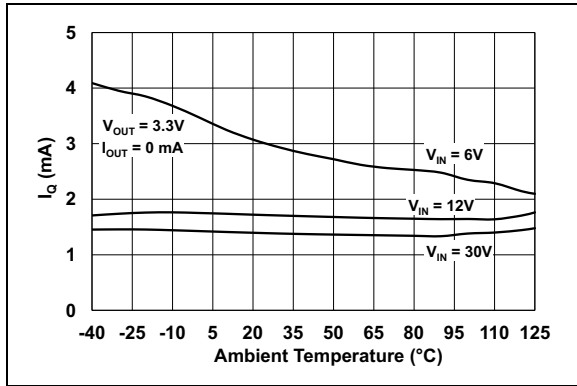

FIGURE 2-7: Input Quiescent Current vs. Temperature.

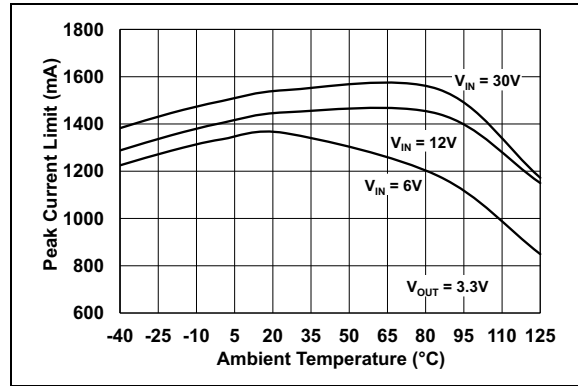

FIGURE 2-10: Peak Current Limit vs. Temperature; $V_{OUT} = 3.3V$.

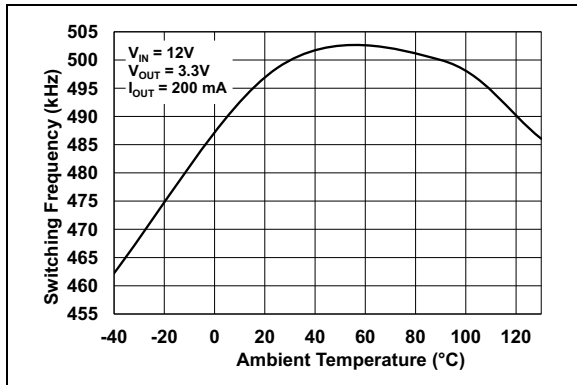

FIGURE 2-8: Switching Frequency vs. Temperature; $V_{OUT} = 3.3V$.

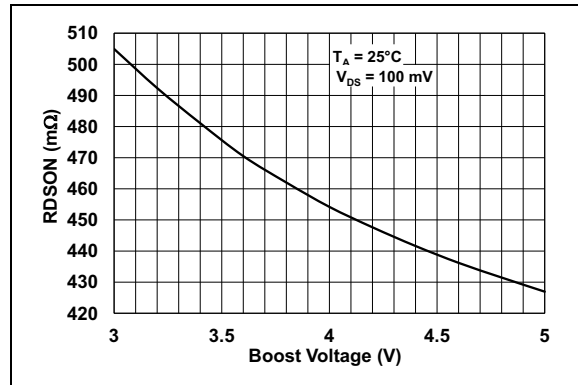

FIGURE 2-11: Switch $R_{DS(on)}$ vs. V_{BOOST} .

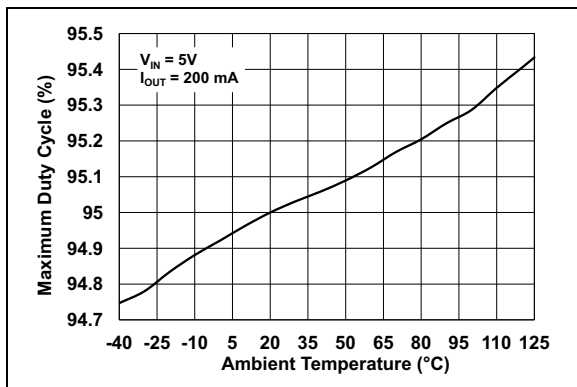

FIGURE 2-9: Maximum Duty Cycle vs. Ambient Temperature; $V_{OUT} = 5.0V$.

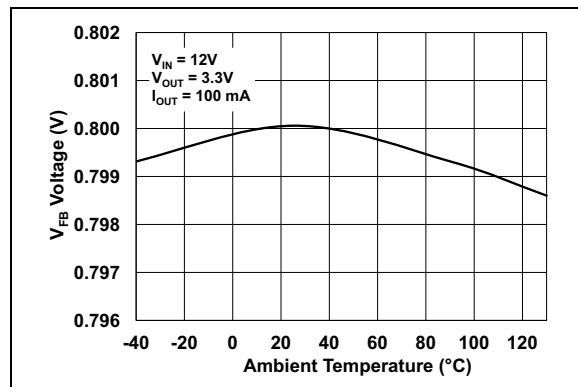

FIGURE 2-12: V_{FB} vs. Temperature; $V_{OUT} = 3.3V$.

Note: Unless otherwise indicated, $V_{IN} = EN = 12V$, $C_{OUT} = C_{IN} = 2 \times 10 \mu F$, $L = 15 \mu H$, $V_{OUT} = 3.3V$, $I_{LOAD} = 200 \text{ mA}$, $T_A = +25^\circ C$.

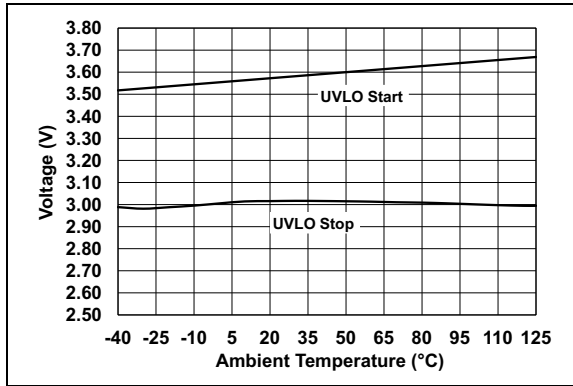

FIGURE 2-13: Undervoltage Lockout vs. Temperature.

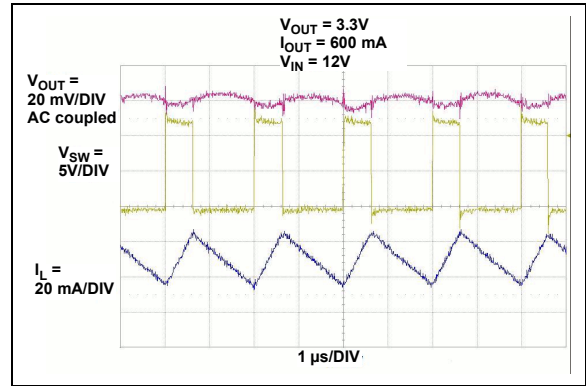

FIGURE 2-16: Heavy Load Switching Waveforms.

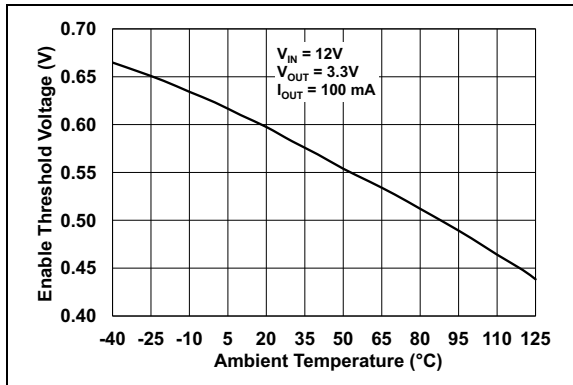

FIGURE 2-14: EN Threshold Voltage vs. Temperature.

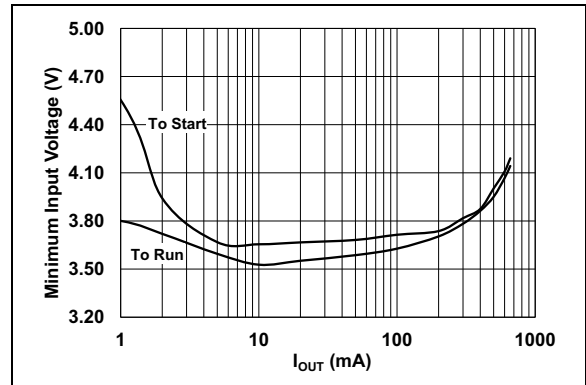

FIGURE 2-17: Typical Minimum Input Voltage vs. Output Current.

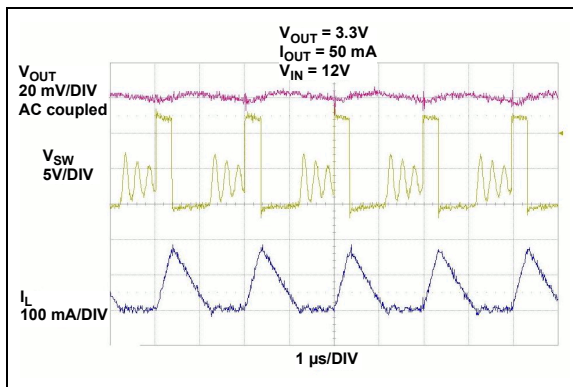

FIGURE 2-15: Light Load Switching Waveforms.

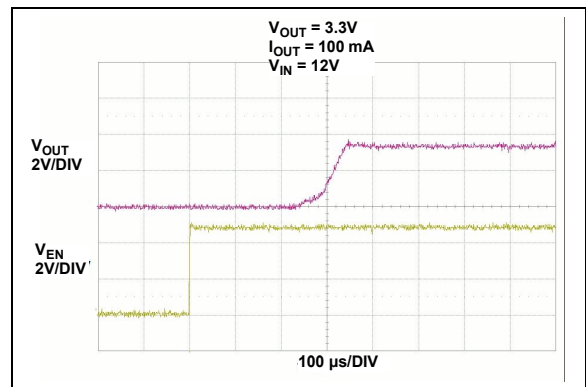

FIGURE 2-18: Start-Up From Enable.

MCP16301/H

Note: Unless otherwise indicated, $V_{IN} = EN = 12V$, $C_{OUT} = C_{IN} = 2 \times 10 \mu F$, $L = 15 \mu H$, $V_{OUT} = 3.3V$, $I_{LOAD} = 200 \text{ mA}$, $T_A = +25^\circ C$.

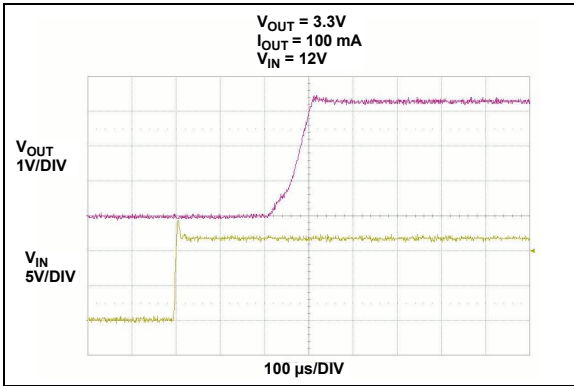

FIGURE 2-19: Start-Up from V_{IN} .

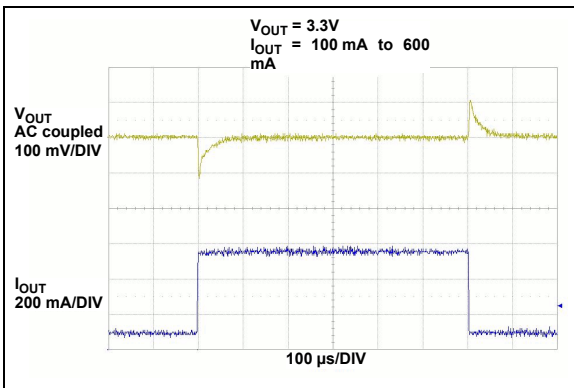

FIGURE 2-20: Load Transient Response.

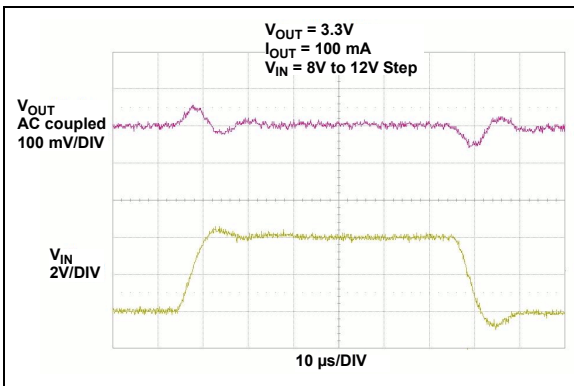

FIGURE 2-21: Line Transient Response.

3.0 PIN DESCRIPTIONS

The descriptions of the pins are listed in [Table 3-1](#).

TABLE 3-1: PIN FUNCTION TABLE

MCP16301/H SOT-23	Symbol	Description
1	BOOST	Boost voltage that drives the internal NMOS control switch. A bootstrap capacitor is connected between the BOOST and SW pins.
2	GND	Ground pin.
3	V _{FB}	Output voltage feedback pin. Connect V _{FB} to an external resistor divider to set the output voltage.
4	EN	Enable pin. Logic high enables the operation. Do not allow this pin to float.
5	V _{IN}	Input supply voltage pin for power and internal biasing.
6	SW	Output switch node. This pin connects to the inductor, the freewheeling diode and the bootstrap capacitor.

3.1 Boost Pin (BOOST)

The high side of the floating supply used to turn the integrated N-Channel MOSFET on and off is connected to the boost pin.

3.2 Ground Pin (GND)

The ground or return pin is used for circuit ground connection. The length of the trace from the input cap return, output cap return and GND pin should be made as short as possible to minimize the noise on the GND pin.

3.3 Feedback Voltage Pin (V_{FB})

The V_{FB} pin is used to provide output voltage regulation by using a resistor divider. The V_{FB} voltage will be 0.800V typical with the output voltage in regulation.

3.4 Enable Pin (EN)

The EN pin is a logic-level input used to enable or disable device switching and to lower the quiescent current while disabled. A logic high (> 1.4V) will enable the regulator output. A logic low (< 0.4V) will ensure that the regulator is disabled.

3.5 Power Supply Input Voltage Pin (V_{IN})

Connect the input voltage source to V_{IN}. The input source should be decoupled to GND with a 4.7 μF-20 μF capacitor, depending on the impedance of the source and output current. The input capacitor provides AC current for the power switch and a stable voltage source for the internal device power. This capacitor should be connected as close as possible to the V_{IN} and GND pins. For lighter load applications, a 1 μF X7R (or X5R, for limited temperature range, -40 to +85°C) ceramic capacitor can be used.

3.6 Switch Pin (SW)

The Switch Node pin is connected internally to the N-Channel switch and externally to the SW node consisting of the inductor and Schottky diode. The SW node can rise very fast as a result of the internal switch turning on. The external Schottky diode should be connected close to the SW node and GND.

MCP16301/H

NOTES:

4.0 DETAILED DESCRIPTION

4.1 Device Overview

The MCP16301/H devices are high-input voltage step-down regulators, capable of supplying 600 mA to a regulated output voltage from 2.0V to 15V. Internally, the trimmed 500 kHz oscillator provides a fixed frequency, while the peak current mode control architecture varies the duty cycle for output voltage regulation. An internal floating driver is used to turn the high-side integrated N-Channel MOSFET on and off. The power for this driver is derived from an external boost capacitor whose energy is supplied from a fixed voltage ranging from 3.0V to 5.5V, typically the input or output voltage of the converter. For applications with an output voltage outside of this range, such as 12V, the boost capacitor bias can be derived from the output using a simple Zener diode regulator.

4.1.1 INTERNAL REFERENCE VOLTAGE (V_{REF})

An integrated precise 0.8V reference combined with an external resistor divider sets the desired converter output voltage. The resistor divider range can vary without affecting the control system gain. High-value resistors consume less current, but are more susceptible to noise.

4.1.2 INTERNAL COMPENSATION

All control system components necessary for stable operation over the entire device operating range are integrated, including the error amplifier and inductor current slope compensation. To add the proper amount of slope compensation, the inductor value changes along with the output voltage (see [Table 5-1](#)).

4.1.3 EXTERNAL COMPONENTS

External components consist of:

- input capacitor
- output filter (inductor and capacitor)
- freewheeling diode
- boost capacitor
- boost blocking diode
- resistor divider.

The selection of the external inductor, output capacitor, input capacitor and freewheeling diode is dependent upon the output voltage and the maximum output current.

4.1.4 ENABLE INPUT

Enable input, (EN), is used to enable and disable the device. If disabled, the MCP16301/H devices consume a minimal current from the input. Once enabled, the internal soft start controls the output voltage rate of rise, preventing high-inrush current and output voltage overshoot.

4.1.5 SOFT START

The internal reference voltage rate of rise is controlled during start-up, minimizing the output voltage overshoot and the inrush current.

4.1.6 UNDERVOLTAGE LOCKOUT

An integrated Undervoltage Lockout (UVLO) prevents the converter from starting until the input voltage is high enough for normal operation. The converter will typically start at 3.5V and operate down to 3.0V. Hysteresis is added to prevent starting and stopping during start-up, as a result of loading the input voltage source.

4.1.7 OVERTEMPERATURE PROTECTION

Overtemperature protection limits the silicon die temperature to +150°C by turning the converter off. The normal switching resumes at +120°C.

MCP16301/H

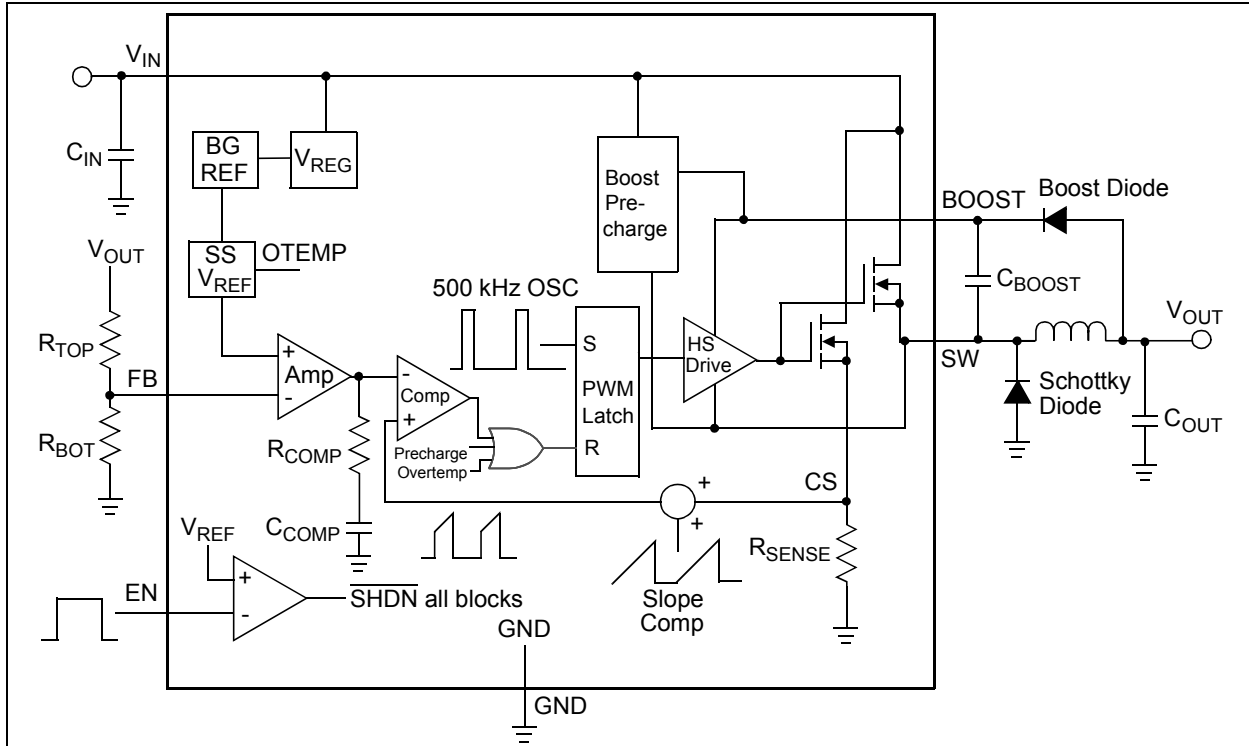

FIGURE 4-1: MCP16301/H Block Diagram.

4.2 Functional Description

4.2.1 STEP-DOWN OR BUCK CONVERTER

The MCP16301/H devices are non-synchronous step-down or buck converters, capable of stepping input voltages ranging from 4V to 30V (MCP16301) or 36V (MCP16301H) down to 2.0V to 15V for $V_{IN} > V_{OUT}$.

The integrated high-side switch is used to chop or modulate the input voltage using a controlled duty cycle for output voltage regulation. High efficiency is achieved by using a low-resistance switch, low forward drop diode, low equivalent series resistance (ESR), an inductor and a capacitor. When the switch is turned on, a DC voltage is applied to the inductor ($V_{IN} - V_{OUT}$), resulting in a positive linear ramp of inductor current. When the switch turns off, the applied inductor voltage is equal to $-V_{OUT}$, resulting in a negative linear ramp of inductor current (ignoring the forward drop of the Schottky diode).

For steady-state, continuous inductor current operation, the positive inductor current ramp must equal the negative current ramp in magnitude. While operating in steady state, the switch duty cycle must be equal to the relationship of V_{OUT}/V_{IN} for constant output voltage regulation, under the condition that the inductor current is continuous or never reaches zero. For discontinuous inductor current operation, the steady-state duty cycle will be less than V_{OUT}/V_{IN} to maintain voltage regulation. The average of the

chopped input voltage or SW node voltage is equal to the output voltage, while the average of the inductor current is equal to the output current.

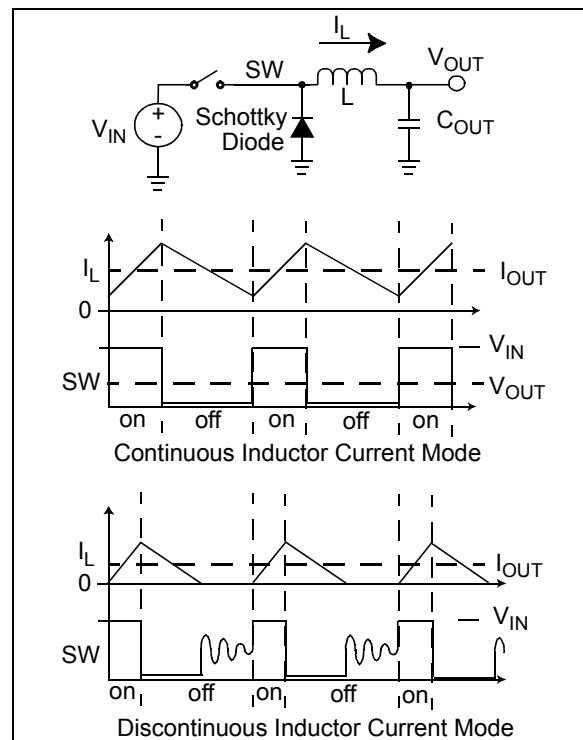

FIGURE 4-2: Step-Down Converter.

4.2.2 PEAK CURRENT MODE CONTROL

The MCP16301/H devices integrate a Peak Current Mode Control architecture, resulting in superior AC regulation while minimizing the number of voltage loop compensation components, and their size, for integration. Peak Current Mode Control takes a small portion of the inductor current, replicates it, and compares this replicated current sense signal to the output of the integrated error voltage. In practice, the inductor current and the internal switch current are equal during the switch-on time. By adding this peak current sense to the system control, the step-down power train system is reduced from a 2nd order to a 1st order. This reduces the system complexity and increases its dynamic performance.

For Pulse-Width Modulation (PWM) duty cycles that exceed 50%, the control system can become bimodal where a wide pulse followed by a short pulse repeats instead of the desired fixed pulse width. To prevent this mode of operation, an internal compensating ramp is summed into the current shown in [Figure 4-1](#).

4.2.3 PULSE-WIDTH MODULATION (PWM)

The internal oscillator periodically starts the switching period, which, for MCP16301, occurs every 2 μ s or 500 kHz. With the integrated switch turned on, the inductor current ramps up until the sum of the current sense and slope compensation ramp exceeds the integrated error amplifier output. The error amplifier output slews up or down to increase or decrease the inductor peak current feeding into the output LC filter. If the regulated output voltage is lower than its target, the inverting error amplifier output rises. This results in an increase in the inductor current to correct the errors in the output voltage.

The fixed-frequency duty cycle is terminated when the sensed inductor peak current, summed with the internal slope compensation, exceeds the output voltage of the error amplifier. The PWM latch is reset by turning off the internal switch and preventing it from turning on until the beginning of the next cycle. An overtemperature signal, or boost cap undervoltage, can also reset the PWM latch to asynchronously terminate the cycle.

4.2.4 HIGH-SIDE DRIVE

The MCP16301/H devices feature an integrated high-side N-Channel MOSFET for high-efficiency step-down power conversion. An N-Channel MOSFET is used for its low resistance and size (instead of a P-Channel MOSFET). The N-Channel MOSFET gate must be driven above its source to fully turn on the transistor. A gate-drive voltage above the input is necessary to turn on the high-side N-Channel. The high-side drive voltage should be between 3.0V and 5.5V. The N-Channel source is connected to the inductor and Schottky diode, or switch node.

When the switch is off, the inductor current flows through the Schottky diode, providing a path to recharge the boost cap from the boost voltage source: typically the output voltage for 3.0V to 5.0V output applications. A boost-blocking diode is used to prevent current flow from the boost cap back into the output during the internal switch-on time. Prior to start-up, the boost cap has no stored charge to drive the switch. An internal regulator is used to precharge the boost cap.

Once precharged, the switch is turned on and the inductor current flows. When the switch turns off, the inductor current free-wheels through the Schottky diode, providing a path to recharge the boost cap. Worst-case conditions for recharge occur when the switch turns on for a very short duty cycle at light load, limiting the inductor current ramp. In this case, there is a small amount of time for the boost capacitor to recharge. For high input voltages there is enough pre-charge current to replace the boost cap charge. For input voltages above 5.5V typical, the MCP16301/H devices will regulate the output voltage with no load. After starting, the MCP16301/H devices will regulate the output voltage until the input voltage decreases below 4V. See [Figure 2-17](#) for device range of operation over input voltage, output voltage and load.

4.2.5 ALTERNATIVE BOOST BIAS

For 3.0V to 5.0V output voltage applications, the boost supply is typically the output voltage. For applications with $3.0V < V_{OUT} < 5.0V$, an alternative boost supply can be used.

Alternative boost supplies can be from the input, input derived, output derived or an auxiliary system voltage.

For low voltage output applications with unregulated input voltage, a shunt regulator derived from the input can be used to derive the boost supply. For applications with high output voltage or regulated high input voltage, a series regulator can be used to derive the boost supply.

MCP16301/H

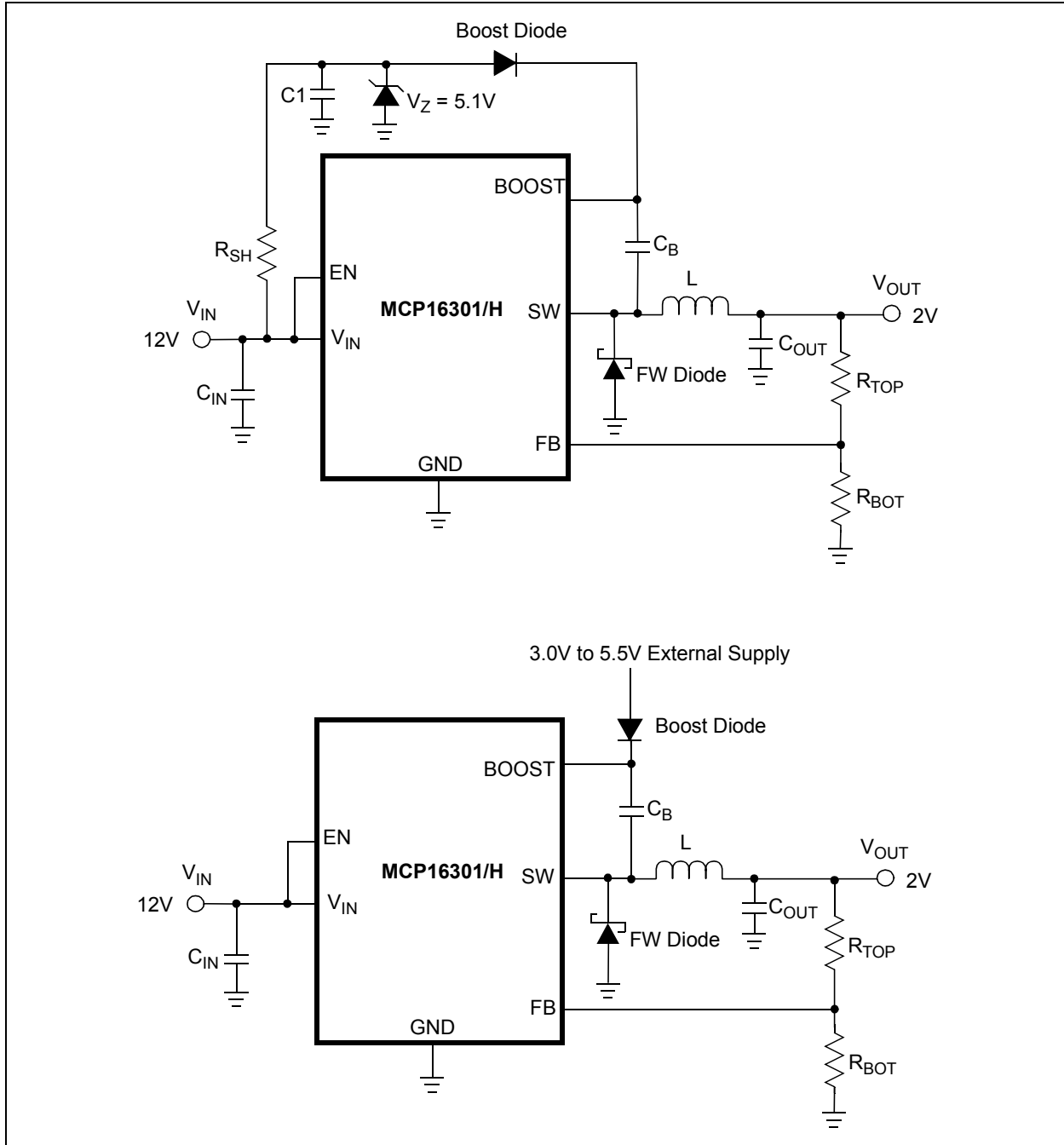

FIGURE 4-3: Shunt and External Boost Supply.

Shunt Boost Supply Regulation is used for low-output voltage converters operating from a wide ranging input source. A regulated 3.0V to 5.5V supply is needed to provide high-side drive bias. The shunt uses a Zener diode to clamp the voltage within the 3.0V to 5.5V range using the resistance shown in [Figure 4-3](#).

To calculate the shunt resistance, the boost drive current can be estimated using [Equation 4-1](#).

I_{BOOST_TYP} for 3.3V Boost Supply = 0.6 mA

I_{BOOST_TYP} for 5.0V Boost Supply = 0.8 mA

EQUATION 4-1: BOOST CURRENT

$$I_{BOOST} = I_{BOOST_TYP} \times 1.5mA$$

To calculate the shunt resistance, the maximum I_{BOOST} and I_Z currents are used at the minimum input voltage (Equation 4-2).

EQUATION 4-2: SHUNT RESISTANCE

$$R_{SH} = \frac{V_{INMIN} - V_Z}{I_{Boost} + I_Z}$$

V_Z and I_Z can be found on the Zener diode manufacturer's data sheet (typical $I_Z = 1\text{ mA}$).

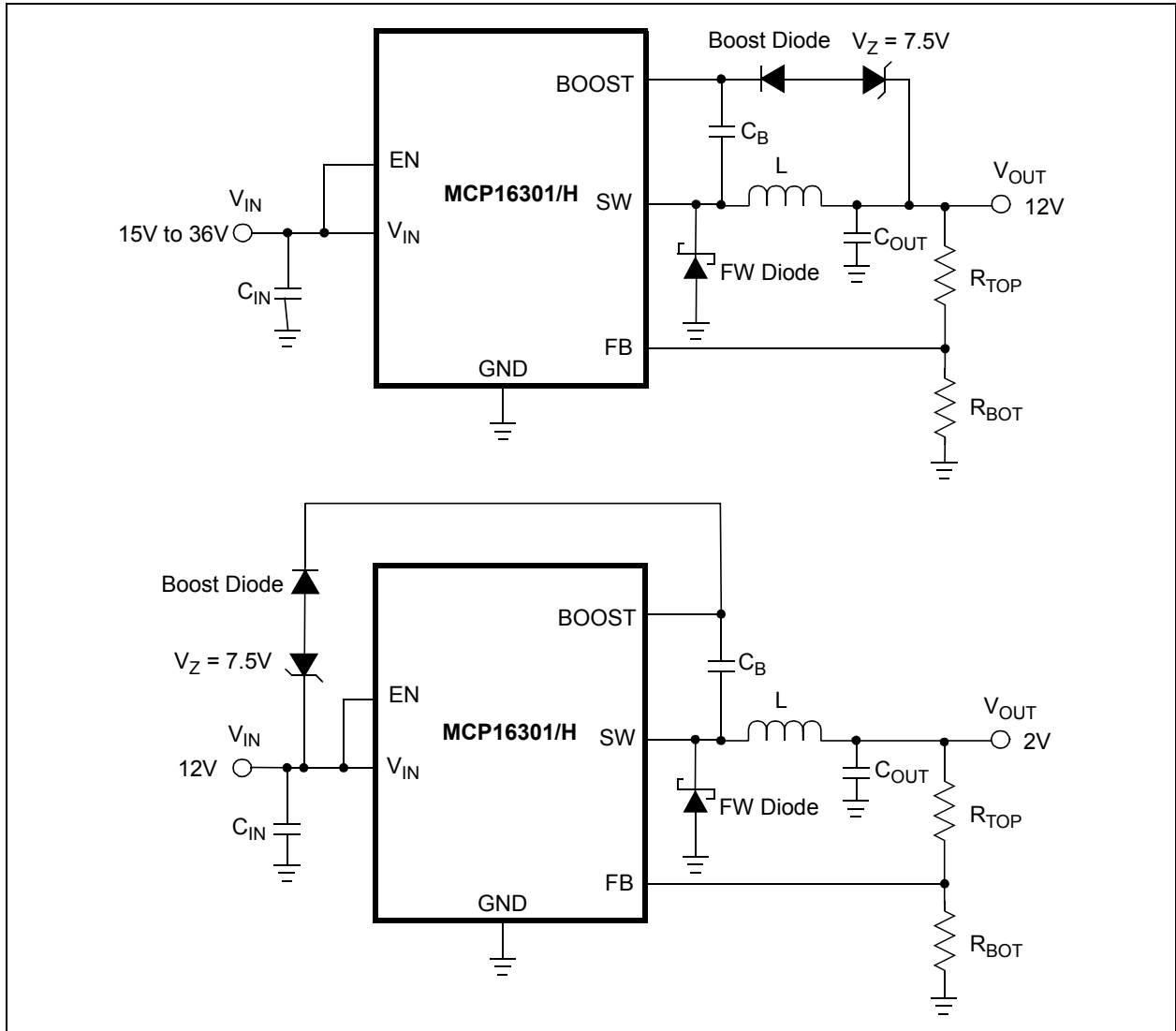

FIGURE 4-4: Series Regulator Boost Supply.

Series regulator applications use a Zener diode to drop the excess voltage. The series regulator bias source can be input or output voltage derived, as shown in Figure 4-4. For proper circuit operation, the boost supply must remain between 3.0V and 5.5V at all times.

MCP16301/H

NOTES:

5.0 APPLICATION INFORMATION

5.1 Typical Applications

The MCP16301/H step-down converters operate over a wide input voltage range, up to 36V maximum. Typical applications include generating a bias or V_{DD} voltage for the PIC® microcontroller product line, digital control system bias supply for AC-DC converters, 24V industrial input and similar applications.

5.2 Adjustable Output Voltage Calculations

To calculate the resistor divider values for the MCP16301/H devices, Equation 5-1 can be used. R_{TOP} is connected to V_{OUT} , R_{BOT} is connected to GND and both are connected to the V_{FB} input pin.

EQUATION 5-1:

$$R_{TOP} = R_{BOT} \times \left(\frac{V_{OUT}}{V_{FB}} - 1 \right)$$

EXAMPLE 5-1:

$$\begin{aligned} V_{OUT} &= 3.3V \\ V_{FB} &= 0.8V \\ R_{BOT} &= 10 \text{ k}\Omega \\ R_{TOP} &= 31.25 \text{ k}\Omega \text{ (standard value = 31.6 k}\Omega\text{)} \\ V_{OUT} &= 3.328V \text{ (using standard value)} \end{aligned}$$

EXAMPLE 5-2:

$$\begin{aligned} V_{OUT} &= 5.0V \\ V_{FB} &= 0.8V \\ R_{BOT} &= 10 \text{ k}\Omega \\ R_{TOP} &= 52.5 \text{ k}\Omega \text{ (standard value = 52.3 k}\Omega\text{)} \\ V_{OUT} &= 4.98V \text{ (using standard value)} \end{aligned}$$

The transconductance error amplifier gain is controlled by its internal impedance. The external divider resistors have no effect on system gain, so a wide range of values can be used. A 10 k Ω resistor is recommended as a good trade-off for quiescent current and noise immunity.

5.3 General Design Equations

The step-down converter duty cycle can be estimated using Equation 5-2 while operating in Continuous Inductor Current mode. This equation also counts the forward drop of the freewheeling diode and internal N-Channel MOSFET switch voltage drop. As the load current increases, the switch voltage drop and diode voltage drop increase, requiring a larger PWM duty cycle to maintain the output voltage regulation. Switch voltage drop is estimated by multiplying the switch current times the switch resistance or $R_{DS(ON)}$.

EQUATION 5-2: CONTINUOUS INDUCTOR CURRENT DUTY CYCLE

$$D = \frac{(V_{OUT} + V_{Diode})}{(V_{IN} - (I_{SW} \times R_{DS(ON)})}$$

The MCP16301/H devices feature an integrated slope compensation to prevent the bimodal operation of the PWM duty cycle. Internally, half of the inductor current down slope is summed with the internal current sense signal. For the proper amount of slope compensation, it is recommended to keep the inductor down-slope current constant by varying the inductance with V_{OUT} , where $K = 0.22V/\mu H$.

EQUATION 5-3:

$$K = V_{OUT}/L$$

For $V_{OUT} = 3.3V$, an inductance of 15 μH is recommended.

TABLE 5-1: RECOMMENDED INDUCTOR VALUES

V_{OUT}	K	$L_{STANDARD}$
2.0V	0.20	10 μH
3.3V	0.22	15 μH
5.0V	0.23	22 μH
12V	0.21	56 μH
15V	0.22	68 μH

MCP16301/H

5.4 Input Capacitor Selection

The step-down converter input capacitor must filter the high input ripple current as a result of pulsing or chopping the input voltage. The input voltage pin of the MCP16301/H devices is used to supply voltage for the power train and as a source for internal bias. A low equivalent series resistance (ESR), preferably a ceramic capacitor, is recommended. The necessary capacitance is dependent upon the maximum load current and source impedance. Three capacitor parameters to keep in mind are the voltage rating, equivalent series resistance and the temperature rating. For wide temperature range applications, a multi-layer X7R dielectric is mandatory, while for applications with limited temperature range, a multi-layer X5R dielectric is acceptable. Typically, input capacitance between 4.7 μF and 10 μF is sufficient for most applications. For applications with 100 mA to 200 mA load, a 1 μF X7R capacitor can be used, depending on the input source and its impedance.

The input capacitor voltage rating should be a minimum of V_{IN} plus margin. [Table 5-2](#) contains the recommended range for the input capacitor value.

5.5 Output Capacitor Selection

The output capacitor helps in providing a stable output voltage during sudden load transients, and reduces the output voltage ripple. As with the input capacitor, X5R and X7R ceramic capacitors are well suited for this application.

The MCP16301/H devices are internally compensated, so the output capacitance range is limited. See [Table 5-2](#) for the recommended output capacitor range.

The amount and type of output capacitance and equivalent series resistance will have a significant effect on the output ripple voltage and system stability. The range of the output capacitance is limited due to the integrated compensation of the MCP16301/H devices.

The output voltage capacitor voltage rating should be a minimum of V_{OUT} , plus margin.

[Table 5-2](#) contains the recommended range for the input and output capacitor value:

TABLE 5-2: CAPACITOR VALUE RANGE

Parameter	Min	Max
C_{IN}	2.2 μF	none
C_{OUT}	20 μF	none

5.6 Inductor Selection

The MCP16301/H devices are designed to be used with small surface mount inductors. Several specifications should be considered prior to selecting an inductor. To optimize system performance, the inductance value is determined by the output voltage ([Table 5-1](#)) so the inductor ripple current is somewhat constant over the output voltage range.

EQUATION 5-4: INDUCTOR RIPPLE CURRENT

$$\Delta I_L = \frac{V_L}{L} \times t_{\text{ON}}$$

EXAMPLE 5-3:

$$\begin{aligned} V_{\text{IN}} &= 12\text{V} \\ V_{\text{OUT}} &= 3.3\text{V} \\ I_{\text{OUT}} &= 600\text{ mA} \end{aligned}$$

EQUATION 5-5: INDUCTOR PEAK CURRENT

$$I_{\text{LPK}} = \frac{\Delta I_L}{2} + I_{\text{OUT}}$$

$$\begin{aligned} \text{Inductor ripple current} &= 319\text{ mA} \\ \text{Inductor peak current} &= 760\text{ mA} \end{aligned}$$

An inductor saturation rating minimum of 760 mA is recommended. Low ESR inductors result in higher system efficiency. A trade-off between size, cost and efficiency is made to achieve the desired results.

TABLE 5-3: MCP16301/H RECOMMENDED 3.3V INDUCTORS

Part Number	Value (µH)	DCR (Ω)	I _{SAT} (A)	Size WxLxH (mm)
Coilcraft®				
ME3220	15	0.52	0.90	3.2x2.5x2.0
LPS4414	15	0.440	0.92	4.3x4.3x1.4
LPS6235	15	0.125	2.00	6.0x6.0x3.5
MSS6132	15	0.135	1.56	6.1x6.1x3.2
MSS7341	15	0.057	1.78	7.3x7.3x4.1
ME3220	15	0.520	0.8	2.8x3.2x2.0
LPS3015	15	0.700	0.61	3.0x3.0x1.4
Würth Elektronik Group®				
744025	15	0.400	0.900	2.8x2.8x2.8
744031	15	0.255	0.450	3.8x3.8x1.65
744042	15	0.175	0.75	4.8x4.8x1.8
Coiltronics®				
SD12	15	0.48	0.692	5.2x5.2x1.2
SD18	15	0.266	0.831	5.2x5.2x1.8
SD20	15	0.193	0.718	5.2x5.2x2.0
SD3118	15	0.51	0.75	3.2x3.2x1.8
SD52	15	0.189	0.88	5.2x5.5x2.0
Sumida® Corporation				
CDPH4D19F	15	0.075	0.66	5.2x5.2x2.0
CDRH3D161H	15	0.328	0.65	4.0x4.0x1.8
TDK-EPC®				
VLF30251	15	0.5	0.47	2.5x3.0x1.2
VLF4012A	15	0.46	0.63	3.5x3.7x1.2
VLF5014A	15	0.28	0.97	4.5x4.7x1.4
B82462G4332M	15	0.097	1.05	6x6x2.2

5.7 Freewheeling Diode

The freewheeling diode creates a path for inductor current flow after the internal switch is turned off. The average diode current is dependent upon output load current at duty cycle (D). The efficiency of the converter is a function of the forward drop and speed of the freewheeling diode. A low forward drop Schottky diode is recommended. The current rating and voltage rating of the diode is application dependent. The diode voltage rating should be a minimum of V_{IN}, plus margin. For example, a diode rating of 40V should be used for an application with a maximum input of 30V. The average diode current can be calculated using Equation 5-6.

EQUATION 5-6: DIODE AVERAGE CURRENT

$$I_{D1AVG} = (1 - D) \times I_{OUT}$$

EXAMPLE 5-4:

I _{OUT}	=	0.5A
V _{IN}	=	15V
V _{OUT}	=	5V
D	=	5/15
I _{D1AVG}	=	333 mA

A 0.5A to 1A diode is recommended.

TABLE 5-4: FREEWHEELING DIODES

App	Manufacturer	Part Number	Rating
12 V _{IN} 600 mA	Diodes Incorporated®	DFLS120L-7	20V, 1A
24 V _{IN} 100 mA	Diodes Incorporated	B0540Ws-7	40V, 0.5A
18 V _{IN} 600 mA	Diodes Incorporated	B130L-13-F	30V, 1A

5.8 Boost Diode

The boost diode is used to provide a charging path from the low-voltage gate drive source, while the switch node is low. The boost diode blocks the high voltage of the switch node from feeding back into the output voltage when the switch is turned on, forcing the switch node high.

A standard 1N4148 ultra-fast diode is recommended for its recovery speed, high voltage blocking capability, availability and cost. The voltage rating required for the boost diode is V_{IN}.

For low boost voltage applications, a small Schottky diode with the appropriately rated voltage can be used to lower the forward drop, increasing the boost supply for gate drive.

MCP16301/H

5.9 Boost Capacitor

The boost capacitor is used to supply current for the internal high-side drive circuitry that is above the input voltage. The boost capacitor must store enough energy to completely drive the high-side switch on and off. A 0.1 μF X5R or X7R capacitor is recommended for all applications. The boost capacitor maximum voltage is 5.5V, so a 6.3V or 10V rated capacitor is recommended. In case of a noise-sensitive application, an additional resistor in series with the boost capacitor, that will reduce the high-frequency noise associated with switching power supplies, can be added. A typical value for the resistor is 82 Ω .

5.10 Thermal Calculations

The MCP16301/H devices are available in a SOT-23-6 package. By calculating the power dissipation and applying the package thermal resistance (θ_{JA}), the junction temperature is estimated. The maximum continuous junction temperature rating for the MCP16301/H devices is +125°C.

To quickly estimate the internal power dissipation for the switching step-down regulator, an empirical calculation using measured efficiency can be used. Given the measured efficiency, the internal power dissipation is estimated by Equation 5-7. This power dissipation includes all internal and external component losses. For a quick internal estimate, subtract the estimated Schottky diode loss and inductor ESR loss from the P_{DIS} calculation in Equation 5-7.

EQUATION 5-7: TOTAL POWER DISSIPATION ESTIMATE

$$\left(\frac{V_{OUT} \times I_{OUT}}{\text{Efficiency}}\right) - (V_{OUT} \times I_{OUT}) = P_{Dis}$$

The difference between the first term, input power, and the second term, power delivered, is the total system power dissipation. The freewheeling Schottky diode losses are determined by calculating the average diode current and multiplying by the diode forward drop. The inductor losses are estimated by $P_L = I_{OUT}^2 \times L_{ESR}$.

EQUATION 5-8: DIODE POWER DISSIPATION ESTIMATE

$$P_{Diode} = V_F \times ((1 - D) \times I_{OUT})$$

EXAMPLE 5-5:

V_{IN}	=	10V
V_{OUT}	=	5V
I_{OUT}	=	0.4A
Efficiency	=	90%
Total System Dissipation	=	222 mW
L_{ESR}	=	0.15 Ω
P_L	=	24 mW
Diode VF	=	0.50
D	=	50%
P_{Diode}	=	125 mW

MCP16301/H internal power dissipation estimate:

$$P_{DIS} - P_L - P_{DIODE} = 73 \text{ mW}$$

θ_{JA}	=	198°C/W
Estimated Junction Temperature Rise	=	+14.5°C

5.11 PCB Layout Information

Good printed circuit board layout techniques are important to any switching circuitry, and switching power supplies are no different. When wiring the switching high-current paths, short and wide traces should be used. Therefore, it is important that the input and output capacitors be placed as close as possible to the MCP16301/H devices to minimize the loop area.

The feedback resistors and feedback signal should be routed away from the switching node and the switching current loop. When possible, ground planes and traces should be used to help shield the feedback signal and minimize noise and magnetic interference.

A good MCP16301/H layout starts with C_{IN} placement. C_{IN} supplies current to the input of the circuit when the switch is turned on. In addition to supplying high-frequency switch current, C_{IN} also provides a stable voltage source for the internal MCP16301/H circuitry. Unstable PWM operation can result if there are excessive transients or ringing on the V_{IN} pin of the MCP16301/H devices. In Figure 5-1, C_{IN} is placed close to pin 5. A ground plane on the bottom of the board provides a low resistive and inductive path for the return current. The next priority in placement is the freewheeling current loop formed by D1, C_{OUT} and L, while strategically placing C_{OUT} return close to C_{IN} return. Next, C_B and D_B should be placed between the boost pin and the switch node pin SW. This leaves space close to the V_{FB} pin of the MCP16301/H devices to place R_{TOP} and R_{BOT} . R_{TOP} and R_{BOT} are routed away from the Switch node so noise is not coupled into the high-impedance V_{FB} input.

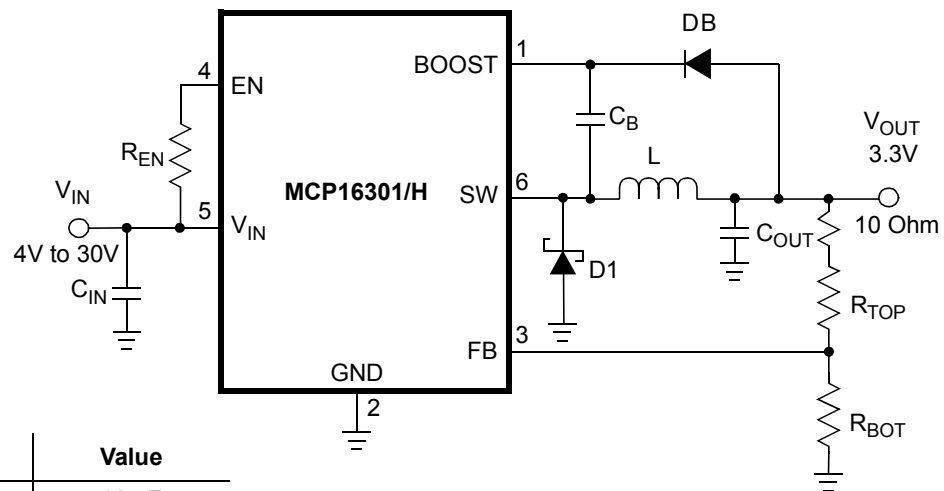
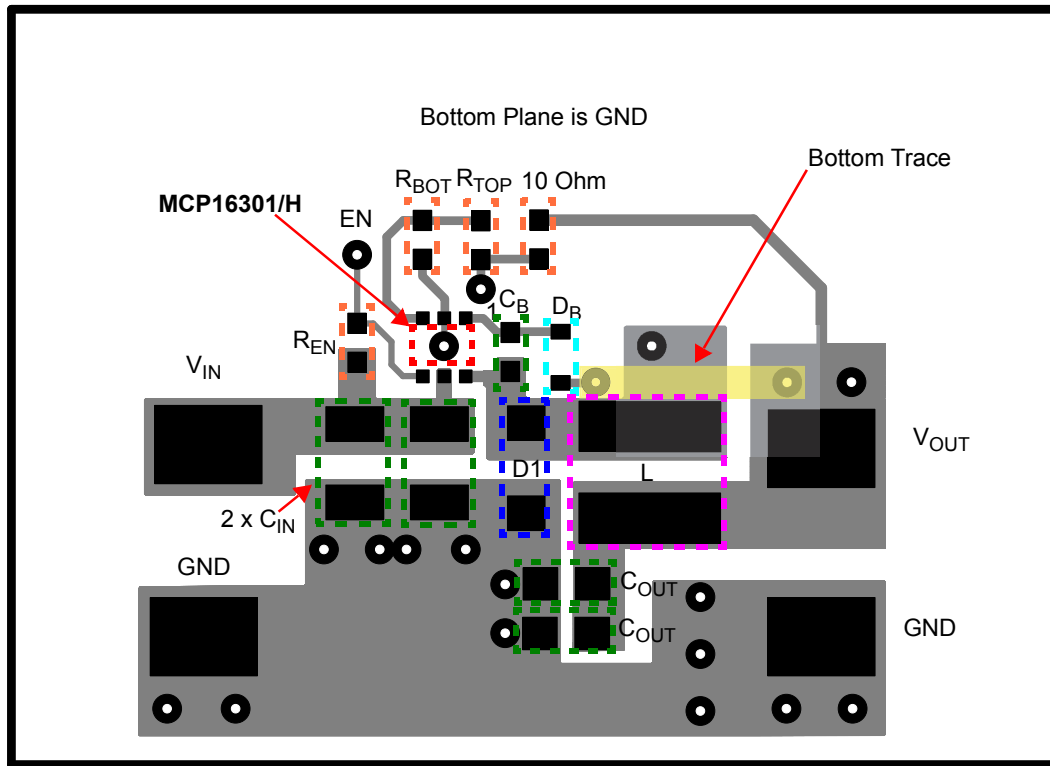

Component	Value
C_{IN}	10 μ F
C_{OUT}	2 x 10 μ F
L	15 μ H
R_{TOP}	31.6 k Ω
R_{BOT}	10 k Ω
D1	B140
D _B	1N4148
C_B	100 nF

***Note:** The 10 Ω resistor is used with network analyzer, to measure system gain and phase.

FIGURE 5-1: MCP16301/H SOT-23-6 Recommended Layout, 600 mA Design.

MCP16301/H

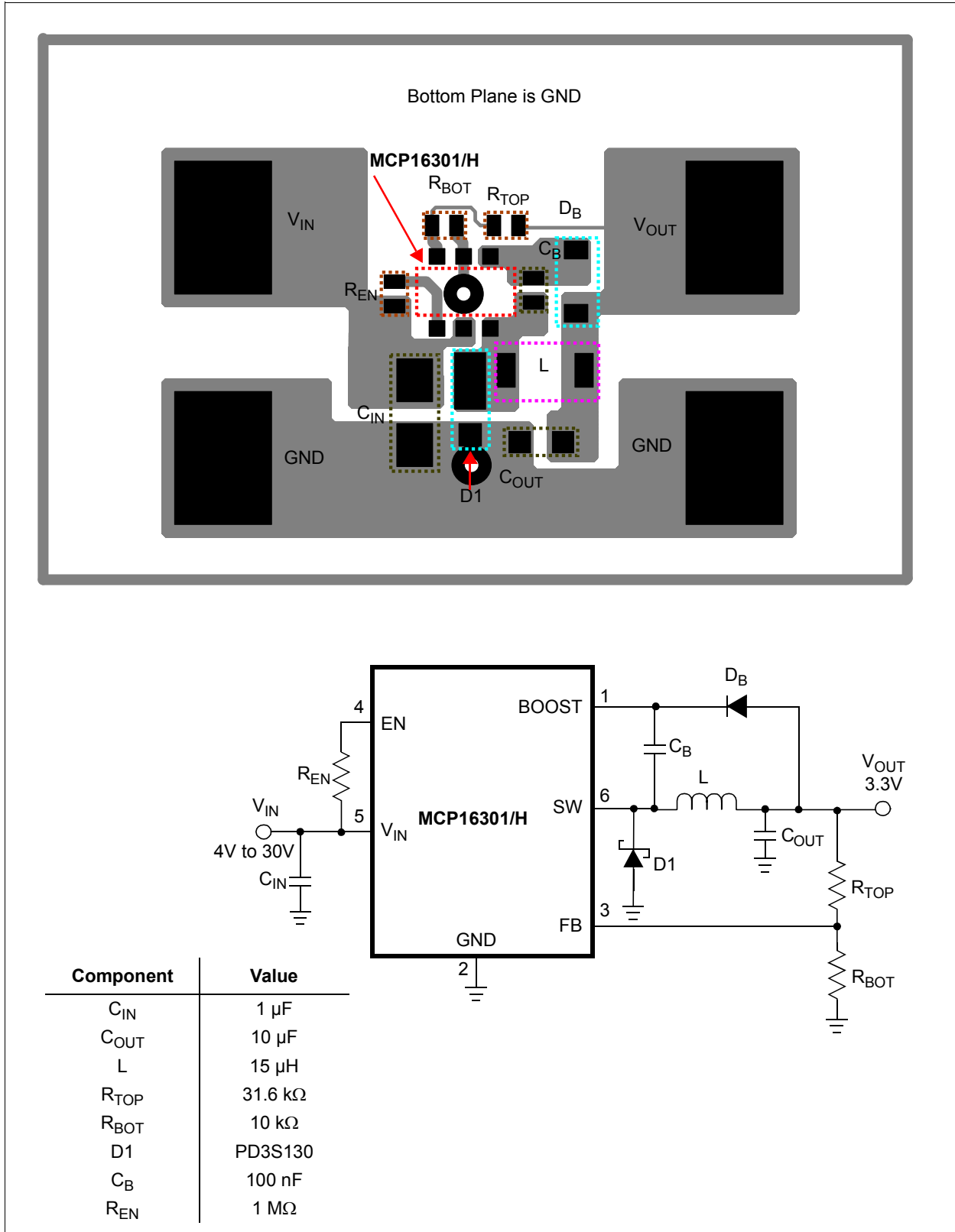

FIGURE 5-2: MCP16301/H SOT-23-6 D² Recommended Layout, 200 mA Design.

6.0 TYPICAL APPLICATION CIRCUITS

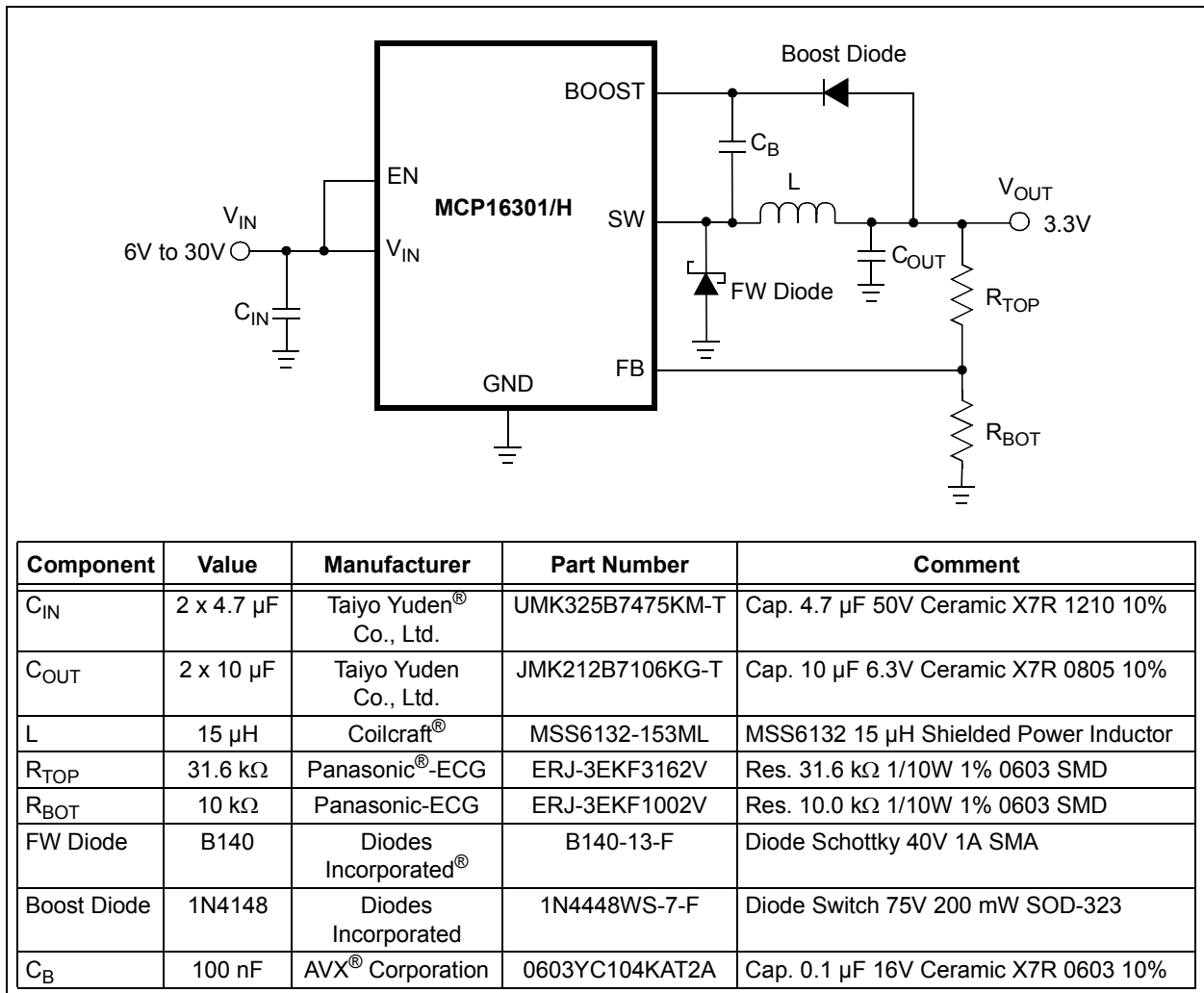
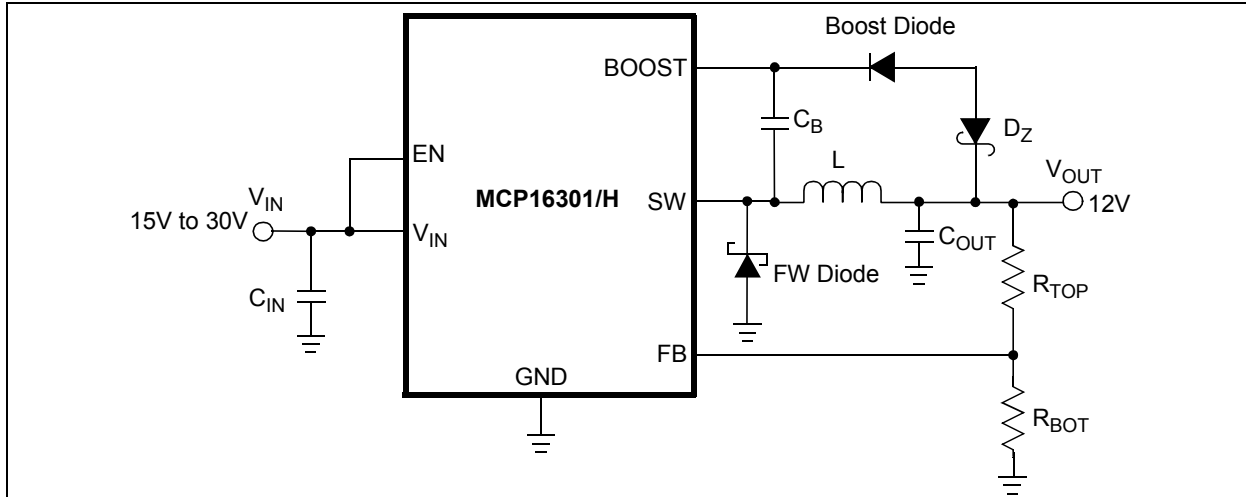

FIGURE 6-1: Typical Application 30V V_{IN} to 3.3V V_{OUT} .

MCP16301/H



Component	Value	Manufacturer	Part Number	Comment
C _{IN}	2 x 4.7 μF	Taiyo Yuden [®] Co., Ltd.	UMK325B7475KM-T	Cap. 4.7 uF 50V Ceramic X7R 1210 10%
C _{OUT}	2 x 10 μF	Taiyo Yuden Co., Ltd.	JMK212B7106KG-T	Cap. Ceramic 10 μF 25V X7R 10% 1206
L	56 μH	Coilcraft [®]	MSS6132-153ML	MSS7341 56 μH Shielded Power Inductor
R _{TOP}	140 kΩ	Panasonic [®] -ECG	ERJ-3EKF3162V	Res. 140 kΩ 1/10W 1% 0603 SMD
R _{BOT}	10 kΩ	Panasonic-ECG	ERJ-3EKF1002V	Res. 10.0 kΩ 1/10W 1% 0603 SMD
FW Diode	B140	Diodes Incorporated [®]	B140-13-F	Diode Schottky 40V 1A SMA
Boost Diode	1N4148	Diodes Incorporated	1N4448WS-7-F	Diode Switch 75V 200 mW SOD-323
C _B	100 nF	AVX [®] Corporation	0603YC104KAT2A	Cap. 0.1 μF 16V Ceramic X7R 0603 10%
D _Z	7.5V Zener	Diodes Incorporated	MMSZ5236BS-7-F	Diode Zener 7.5V 200 mW SOD-323

FIGURE 6-2: Typical Application 15V – 30V Input; 12V Output.

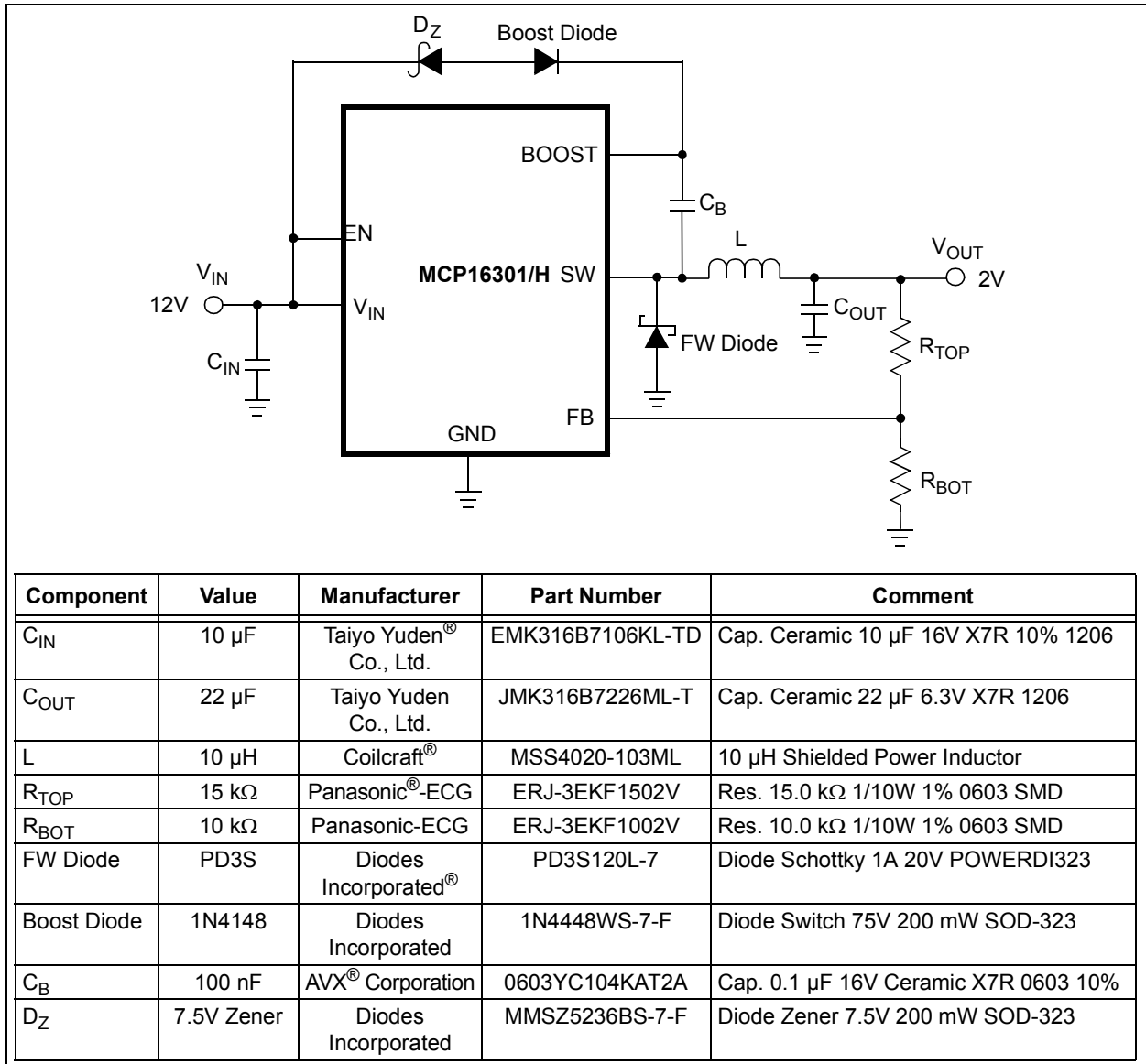

FIGURE 6-3: Typical Application 12V Input; 2V Output at 600 mA.