



Chipsmall Limited consists of a professional team with an average of over 10 year of expertise in the distribution of electronic components. Based in Hongkong, we have already established firm and mutual-benefit business relationships with customers from,Europe,America and south Asia,supplying obsolete and hard-to-find components to meet their specific needs.

With the principle of “Quality Parts,Customers Priority,Honest Operation,and Considerate Service”,our business mainly focus on the distribution of electronic components. Line cards we deal with include Microchip,ALPS,ROHM,Xilinx,Pulse,ON,Everlight and Freescale. Main products comprise IC,Modules,Potentiometer,IC Socket,Relay,Connector.Our parts cover such applications as commercial,industrial, and automotives areas.

We are looking forward to setting up business relationship with you and hope to provide you with the best service and solution. Let us make a better world for our industry!



Contact us

Tel: +86-755-8981 8866 Fax: +86-755-8427 6832

Email & Skype: info@chipsmall.com Web: www.chipsmall.com

Address: A1208, Overseas Decoration Building, #122 Zhenhua RD., Futian, Shenzhen, China





**MCP1630 NiMH
Battery Charger Demo Board
User's Guide**

Note the following details of the code protection feature on Microchip devices:

- Microchip products meet the specification contained in their particular Microchip Data Sheet.
- Microchip believes that its family of products is one of the most secure families of its kind on the market today, when used in the intended manner and under normal conditions.
- There are dishonest and possibly illegal methods used to breach the code protection feature. All of these methods, to our knowledge, require using the Microchip products in a manner outside the operating specifications contained in Microchip's Data Sheets. Most likely, the person doing so is engaged in theft of intellectual property.
- Microchip is willing to work with the customer who is concerned about the integrity of their code.
- Neither Microchip nor any other semiconductor manufacturer can guarantee the security of their code. Code protection does not mean that we are guaranteeing the product as "unbreakable."

Code protection is constantly evolving. We at Microchip are committed to continuously improving the code protection features of our products. Attempts to break Microchip's code protection feature may be a violation of the Digital Millennium Copyright Act. If such acts allow unauthorized access to your software or other copyrighted work, you may have a right to sue for relief under that Act.

Information contained in this publication regarding device applications and the like is provided only for your convenience and may be superseded by updates. It is your responsibility to ensure that your application meets with your specifications. MICROCHIP MAKES NO REPRESENTATIONS OR WARRANTIES OF ANY KIND WHETHER EXPRESS OR IMPLIED, WRITTEN OR ORAL, STATUTORY OR OTHERWISE, RELATED TO THE INFORMATION, INCLUDING BUT NOT LIMITED TO ITS CONDITION, QUALITY, PERFORMANCE, MERCHANTABILITY OR FITNESS FOR PURPOSE. Microchip disclaims all liability arising from this information and its use. Use of Microchip devices in life support and/or safety applications is entirely at the buyer's risk, and the buyer agrees to defend, indemnify and hold harmless Microchip from any and all damages, claims, suits, or expenses resulting from such use. No licenses are conveyed, implicitly or otherwise, under any Microchip intellectual property rights.

Trademarks

The Microchip name and logo, the Microchip logo, Accuron, dsPIC, KEELOQ, microID, MPLAB, PIC, PICmicro, PICSTART, PRO MATE, PowerSmart, rfPIC and SmartShunt are registered trademarks of Microchip Technology Incorporated in the U.S.A. and other countries.

AmpLab, FilterLab, Migratable Memory, MXDEV, MXLAB, SEEVAL, SmartSensor and The Embedded Control Solutions Company are registered trademarks of Microchip Technology Incorporated in the U.S.A.

Analog-for-the-Digital Age, Application Maestro, dsPICDEM, dsPICDEM.net, dsPICworks, ECAN, ECONOMONITOR, FanSense, FlexROM, fuzzyLAB, In-Circuit Serial Programming, ICSP, ICEPIC, Linear Active Thermistor, MPASM, MPLIB, MPLINK, MPSIM, PICkit, PICDEM, PICDEM.net, PICLAB, PICtail, PowerCal, PowerInfo, PowerMate, PowerTool, REAL ICE, rLAB, rfPICDEM, Select Mode, Smart Serial, SmartTel, Total Endurance, UNI/O, WiperLock and ZENA are trademarks of Microchip Technology Incorporated in the U.S.A. and other countries.

SQTP is a service mark of Microchip Technology Incorporated in the U.S.A.

All other trademarks mentioned herein are property of their respective companies.

© 2006, Microchip Technology Incorporated, Printed in the U.S.A., All Rights Reserved.

 Printed on recycled paper.

**QUALITY MANAGEMENT SYSTEM
CERTIFIED BY DNV
== ISO/TS 16949:2002 ==**

Microchip received ISO/TS-16949:2002 certification for its worldwide headquarters, design and wafer fabrication facilities in Chandler and Tempe, Arizona, Gresham, Oregon and Mountain View, California. The Company's quality system processes and procedures are for its PICmicro® 8-bit MCUs, KEELOQ® code hopping devices, Serial EEPROMs, microperipherals, nonvolatile memory and analog products. In addition, Microchip's quality system for the design and manufacture of development systems is ISO 9001:2000 certified.



MCP1630 NiMH BATTERY CHARGER DEMO BOARD USER'S GUIDE

Table of Contents

Preface	1
Chapter 1. Product Overview	5
1.1 Introduction	5
1.2 What is the MCP1630 NiMH Battery Charger Demo Board?	6
1.3 What the MCP1630 NiMH Battery Charger Demo Board Kit Includes	6
Chapter 2. Installation and Operation	7
2.1 Introduction	7
2.2 Features	7
2.3 Getting Started	8
Appendix A. Schematic and Layouts	11
A.1 Introduction	11
A.2 Board Schematic - Page 1	12
A.3 Board Schematic - Page 2	13
A.4 Board - Top Layer	14
A.5 Board - Bottom Layer	15
A.6 Board - Mid-Layer 1	16
A.7 Board - Mid-Layer 2	17
Appendix B. Bill Of Materials (BOM)	19
Appendix C. Evaluation Board Firmware	21
C.1 Device Firmware	21
Worldwide Sales and Service	24

MCP1630 NiMH Battery Charger Demo Board User's Guide

NOTES:



MCP1630 NiMH BATTERY CHARGER DEMO BOARD USER'S GUIDE

Preface

NOTICE TO CUSTOMERS

All documentation becomes dated, and this manual is no exception. Microchip tools and documentation are constantly evolving to meet customer needs, so some actual dialogs and/or tool descriptions may differ from those in this document. Please refer to our web site (www.microchip.com) to obtain the latest documentation available.

Documents are identified with a "DS" number. This number is located on the bottom of each page, in front of the page number. The numbering convention for the DS number is "DSXXXXA", where "XXXX" is the document number and "A" is the revision level of the document.

For the most up-to-date information on development tools, see the MPLAB® IDE on-line help. Select the Help menu, and then Topics to open a list of available on-line help files.

INTRODUCTION

This chapter contains general information that will be useful to know before using the MCP1630 NiMH Battery Charger Demo Board. Items discussed in this chapter include:

- Document Layout
- Conventions Used in this Guide
- Recommended Reading
- The Microchip Web Site
- Customer Support
- Document Revision History

DOCUMENT LAYOUT

This document describes how to use the MCP1630 NiMH Battery Charger Demo Board. The manual layout is as follows:

- **Chapter 1. "Product Overview"** – Important information about the MCP1630 NiMH Battery Charger Demo Board.
- **Chapter 2. "Installation and Operation"** – This chapter includes instructions on how to get started, as well as a description of the MCP1630 NiMH Battery Charger Demo Board.
- **Appendix A. "Schematic and Layouts"** – Shows the schematic and layout diagrams for the MCP1630 NiMH Battery Charger Demo Board.
- **Appendix B. "Bill Of Materials (BOM)"** – Lists the parts used to build the MCP1630 NiMH Battery Charger Demo Board.
- **Appendix C. "Evaluation Board Firmware"** – Provides information about the application firmware and where the source code can be found.

MCP1630 NiMH Battery Charger Demo Board User's Guide

CONVENTIONS USED IN THIS GUIDE

This manual uses the following documentation conventions:

DOCUMENTATION CONVENTIONS

Description	Represents	Examples
Arial font:		
Italic characters	Referenced books	<i>MPLAB[®] IDE User's Guide</i>
	Emphasized text	...is the <i>only</i> compiler...
Initial caps	A window	the Output window
	A dialog	the Settings dialog
	A menu selection	select Enable Programmer
Quotes	A field name in a window or dialog	"Save project before build"
Underlined, italic text with right angle bracket	A menu path	<u><i>File>Save</i></u>
Bold characters	A dialog button	Click OK
	A tab	Click the Power tab
N'Rnnnn	A number in verilog format, where N is the total number of digits, R is the radix and n is a digit.	4'b0010, 2'hF1
Text in angle brackets < >	A key on the keyboard	Press <Enter>, <F1>
Courier New font:		
Plain Courier New	Sample source code	#define START
	Filenames	autoexec.bat
	File paths	c:\mcc18\h
	Keywords	_asm, _endasm, static
	Command-line options	-Opa+, -Opa-
	Bit values	0, 1
	Constants	0xFF, 'A'
Italic Courier New	A variable argument	<i>file.o</i> , where <i>file</i> can be any valid filename
Square brackets []	Optional arguments	mcc18 [options] <i>file</i> [options]
Curly brackets and pipe character: { }	Choice of mutually exclusive arguments; an OR selection	errorlevel {0 1}
Ellipses...	Replaces repeated text	var_name [, var_name...]
	Represents code supplied by user	void main (void) { ... }

RECOMMENDED READING

This user's guide describes how to use the MCP1630 NiMH Battery Charger Demo Board. The following Microchip documents are available and recommended as supplemental reference resources.

MCP1630 Data Sheet, "High-Speed, Microcontroller-Adaptable, Pulse Width Modulator" (DS21896)

This data sheet provides detailed information regarding the MCP1630 product family.

THE MICROCHIP WEB SITE

Microchip provides online support via our web site at www.microchip.com. This web site is used as a means to make files and information easily available to customers. Accessible by using your favorite internet browser, the web site contains the following information:

- **Product Support** – Data sheets and errata, application notes and sample programs, design resources, user's guides and hardware support documents, latest software releases and archived software
- **General Technical Support** – Frequently Asked Questions (FAQs), technical support requests, online discussion groups, Microchip consultant program member listing
- **Business of Microchip** – Product selector and ordering guides, latest Microchip press releases, listing of seminars and events, listings of Microchip sales offices, distributors and factory representatives

CUSTOMER SUPPORT

Users of Microchip products can receive assistance through several channels:

- Distributor or Representative
- Local Sales Office
- Field Application Engineer (FAE)
- Technical Support
- Development Systems Information Line

Customers should contact their distributor, representative or field application engineer for support. Local sales offices are also available to help customers. A listing of sales offices and locations is included in the back of this document.

Technical support is available through the web site at: <http://support.microchip.com>

DOCUMENT REVISION HISTORY

Revision B (March 2006)

- Updated Bill of Materials (BOM) to show RoHS-compliant part numbers.

Revision A (September 2004)

- Initial Release of this Document.

MCP1630 NiMH Battery Charger Demo Board User's Guide

NOTES:

Chapter 1. Product Overview

1.1 INTRODUCTION

The MCP1630 NiMH Battery Charger Demo Board is used to evaluate the Microchip MCP1630 used in a SEPIC power-converter application. The evaluation board is a complete stand-alone 4-cell NiMH battery charger that utilizes an 8V to 15V input capable of charging 4 NiMH batteries in series.

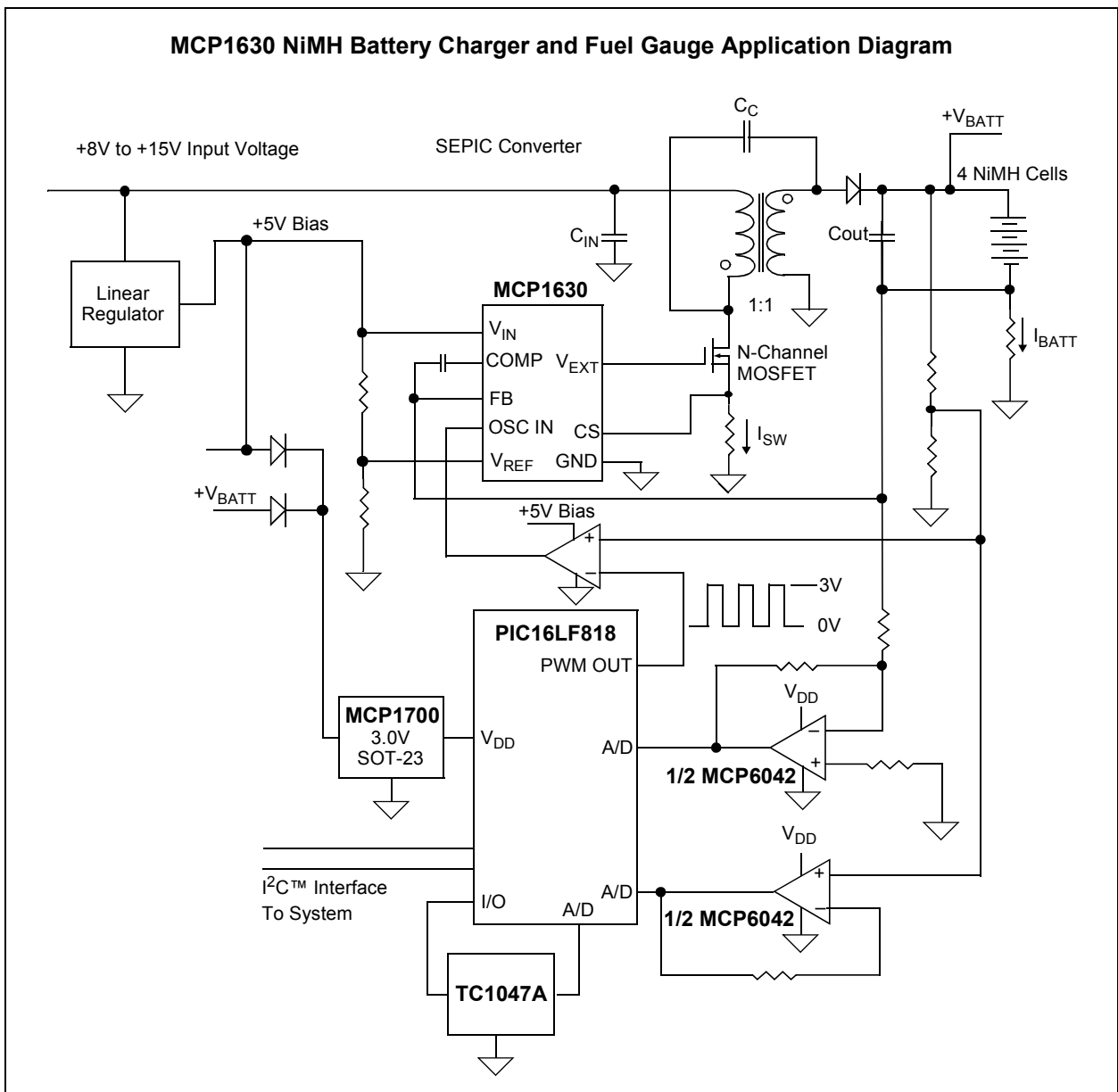

FIGURE 1-1: NiMH Charger Block Diagram.

MCP1630 NiMH Battery Charger Demo Board User's Guide

1.2 WHAT IS THE MCP1630 NIMH BATTERY CHARGER DEMO BOARD?

The MCP1630 NiMH Battery Charger Demo Board is a complete stand-alone constant current battery charger and simple fuel gauge for four NiMH series batteries. This board utilizes Microchip's MCP1630 (high-speed PIC[®] MCU PWM MSOP-8), MCP1700T (LDO Regulator SOT-23), MCP6042T (Op Amp MSOP-8), PIC16LF818 (MCU Flash SSOP-20), TC54 (Voltage Detector SOT-23A) and TC1047A (Temp-Volt Converter SOT-23B). The input voltage range for the demo board is 8V to 15V. The output is capable of charging four NiMH batteries with up to 1.6V per cell at a fast charge rate of 500 mA constant current.

Input terminals are provided to apply an input voltage to the charger. Output terminals are also provided as a way to connect the external NiMH batteries or a simulated battery load.

1.3 WHAT THE MCP1630 NIMH BATTERY CHARGER DEMO BOARD KIT INCLUDES

This MCP1630 NiMH Battery Charger Demo Board Kit includes:

- The MCP1630 NiMH Battery Charger Demo Board
- MCP1630 NiMH Battery Charger Demo Board User's Guide (DS51505)
- MCP1630 Data Sheet, "*High-Speed, Microcontroller-Adaptable, Pulse Width Modulator*" (DS21896)



MCP1630 NiMH BATTERY CHARGER DEMO BOARD USER'S GUIDE

Chapter 2. Installation and Operation

2.1 INTRODUCTION

The MCP1630 NiMH Battery Charger Demo Board demonstrates Microchip's MCP1630 high-speed Pulse Width Modulator (PWM) used in a smart battery charger application. The MCP1630 is a high-speed, microcontroller-adaptable PWM that, when used in conjunction with a microcontroller, will control the power system duty cycle to provide output voltage or current regulation. The PIC16LF818 microcontroller can be used to regulate output voltage or current, switching frequency and maximum duty cycle. The MCP1630 generates pulse-by-pulse duty cycle, provides fast overcurrent protection and utilizes variable external inputs. External signals include the input oscillator and the reference voltage. The power train signals include the current sense and the feedback voltage; the output signal is a square-wave pulse. The power train used for the MCP1630 NiMH Battery Charger Demo Board is a Single-Ended Primary Inductive Converter (SEPIC).

2.2 FEATURES

The MCP1630 NiMH Battery Charger Demo Board has the following features:

- Programmed charge currents:
 - Fast Charge = 500 mA
 - Trickle Charge = 50 mA
 - Top-Off Charge = 25 mA
- Overvoltage protection (battery removed)
- Overcharge protection to prevent the battery from becoming dangerously overcharged
- Overdischarge protection to prevent the battery from being damaged
- Overcurrent protection in the event of a shorted battery
- Battery reversal protection
- Input short circuit protection
- Fast charge termination if the battery or ambient temperature is too high
- Soft-start capability by holding the reference voltage low during power-up
- The MCP1630 NiMH Battery Charger Demo Board terminates charge by detecting a predefined change in voltage with respect to time, a specified temperature or specified elapsed time
- A simple fuel gauge that has a dual MCP6042 amplifier, a 1-channel sense voltage and a 1-channel sense current
- The MCP1630 NiMH Battery Charger Demo Board has the flexibility to optimize the charging algorithm for new battery technology and add proprietary features by coding the microcontroller
- Ability to adapt to environmental effects, such as ambient temperature
- Uses a very low standby current of 29 μ A

MCP1630 NiMH Battery Charger Demo Board User's Guide

2.3 GETTING STARTED

The MCP1630 NiMH Battery Charger Demo Board is fully assembled and tested for charging four 1,000 mA/hour NiMH batteries in series from 3.2V to 6V in accordance with the recommended charge profile for NiMH batteries. This board requires the use of an external input voltage source (+8V to +15V) and external load (battery or simulated battery load). It is recommended that four NiMH cells connected in series to act as a load or the recommended simulated load be used.

2.3.1 Power Input and Output Connections

2.3.1.1 POWERING THE MCP1630 NiMH BATTERY CHARGER DEMO BOARD.

1. Apply the input voltage to the surface mount test points provided. The input voltage source should be limited to the 0V to +15V range. For normal operation, the input voltage should be between +8V and +15V. However, the input voltage must not exceed +15V maximum. The source current necessary to regulate the output voltage to 6.4V at 500 mA should be a minimum of approximately 800 mA.
2. Connect the positive side of the input source (+) to test point TP2. Connect the negative (or return side) (-) of the input source to the GND test point TP3. TP2 is located just above TP3 in the upper-left corner of the board.

2.3.1.2 APPLYING THE LOAD TO THE MCP1630 NiMH BATTERY CHARGER DEMO BOARD.

1. To apply a load to the MCP1630 NiMH Battery Charger Demo Board, the positive side of the load (+) should be connected to test point TP1. The negative side of the load (-) should be connected to test point TP4. Care should be taken when using electronic or ground-referenced loads, and never connect TP4 to ground. The battery current sense is referenced in the return leg, so connecting TP4 to ground will short out the current sense. The typical charge current is 50 mA while the battery is in the Trickle Charge mode or the battery voltage is below 0.8V/cell. The current is typically 500 mA when the battery is in the Fast Charge mode and typically 25 mA when the battery is in the Top-off Charge mode. The charge current is automatically regulated by the MCP1630.
2. The code will prevent the board from entering the 500 mA Fast Charge mode if the battery terminal voltage is less than 3.2V (0.8V / Cell). During power up, the board will always trickle charge first, so using a purely resistive load will not work for trickle and fast charge currents. The best way to evaluate the charger is to use four series NiMH batteries or the recommended simulated battery load.

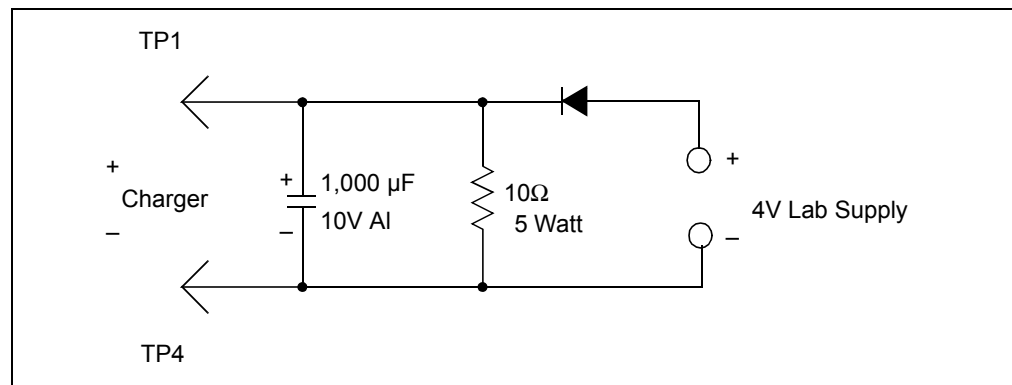

FIGURE 2-1: Simulated Battery Load.

2.3.1.3 STATUS LEDES

The MCP1630 NiMH Battery Charger Demo Board has two LEDs. D₁ is a red LED that is used to indicate when input power is available. When the +12V input is connected, D₁ will be illuminated. The other LED (D₉) has two LEDs built into a SOT-23 package. These can be off, red, green or both on (amber). To conserve energy, D₉ is never illuminated when there is no input power. If both LEDs are off, that is an indication there is no power supplied to the board input.

Under normal power-up conditions, the charger will begin with a 50 mA trickle charge. The microcontroller will then check the status of the batteries to ensure that they are present, their temperature is within range and the series voltage is within specified charging limits. For visual LED charge status, a dual-color SOT-23 LED is used (D₉).

- D₉ Status Indication Normal Charge Modes:

Normal Charge Mode Board Status	Red LED	Green LED
Initial Trickle Charge (50 mA)	ON (Solid)	OFF
Fast Charge (500 mA)	ON (Solid)	ON (Solid)
Final Trickle Charge (50 mA)	OFF	ON (Solid)
Top Off Charge (25 mA)	OFF	ON (Solid)
Charge Complete (0 mA)	OFF	ON (Blinking, 1 sec)
Initial Trickle Charge (50 mA)	ON (Solid)	OFF

- D₉ Status Indication for Fault Modes:

Fault Mode Board Status	Red LED	Green LED
Overvoltage Initial (Restart Initiated)	ON (Blinking)	OFF
Overvoltage (Persistent, Latched-off after 9 attempts)	ON (Blinking Faster)	OFF
Overcurrent	ON Blinking	OFF

With no input connected and 4 NiMH batteries used as a load, the MCP1630 NiMH Battery Charger Demo Board will consume approximately 29 μ A from the battery.

A temperature sensor is provided for charge termination. The sensor (U2) is located on the back of the printed circuit board. To utilize this feature, batteries should be in physical contact with the temperature sensor.

Programming:

- J1 can be used as a Flash programming port to modify the code for prototype applications. The pinout of J1 matches the required pinout for the MPLAB[®] ICD 2 programmer.

MCP1630 NiMH Battery Charger Demo Board User's Guide

NOTES:



MCP1630 NiMH BATTERY CHARGER DEMO BOARD USER'S GUIDE

Appendix A. Schematic and Layouts

A.1 INTRODUCTION

This appendix contains the schematics and layouts for the MCP1630 NiMH Battery Charger Demo Board. The diagrams included in this appendix include:

- Board Schematic
- Board - Top Layer
- Board - Bottom Layer
- Board - Mid-Layer 1
- Board - Mid-Layer 2

MCP1630 NiMH Battery Charger Demo Board User's Guide

A.2 BOARD SCHEMATIC - PAGE 1

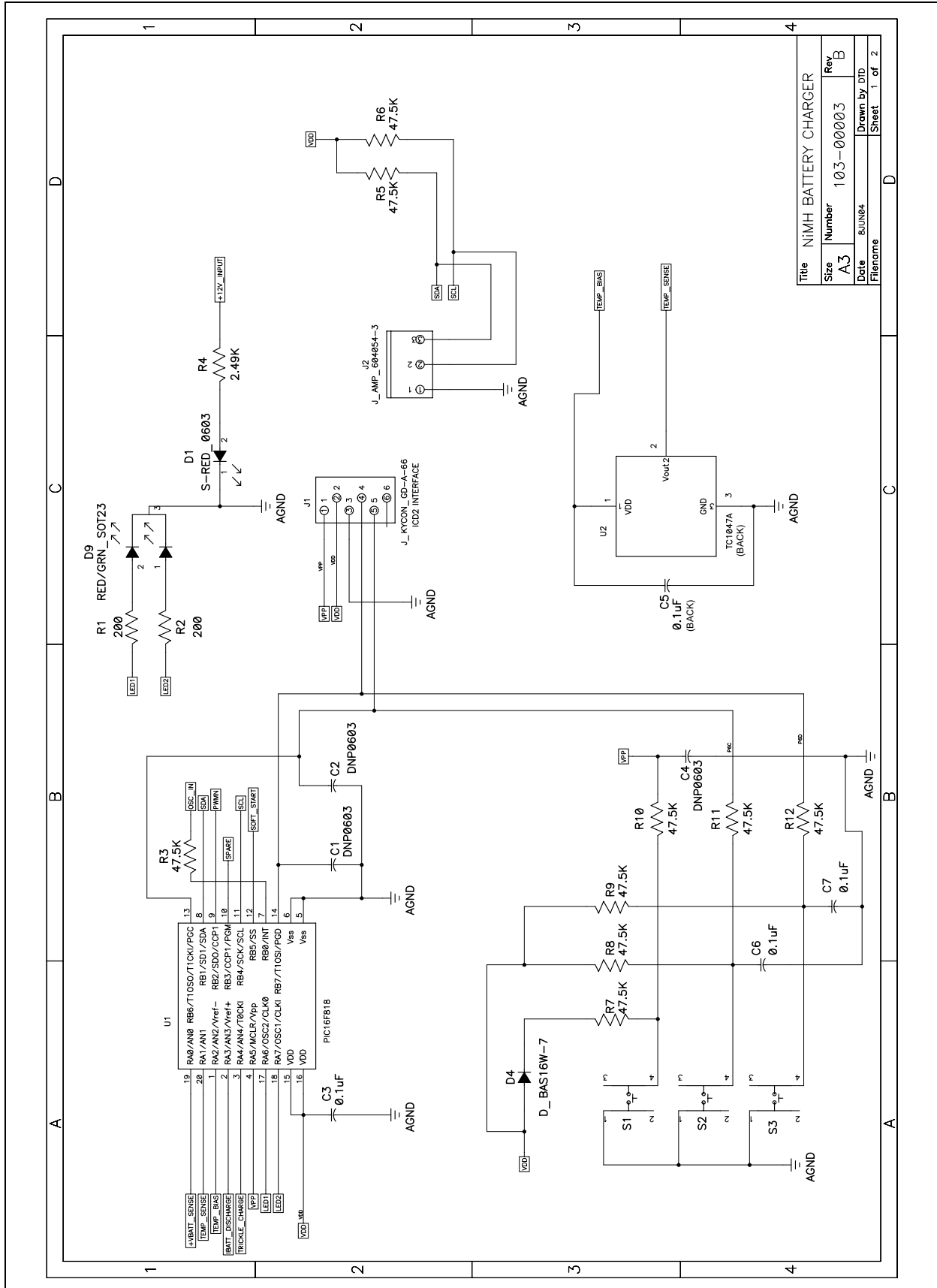

A.3 BOARD SCHEMATIC - PAGE 2

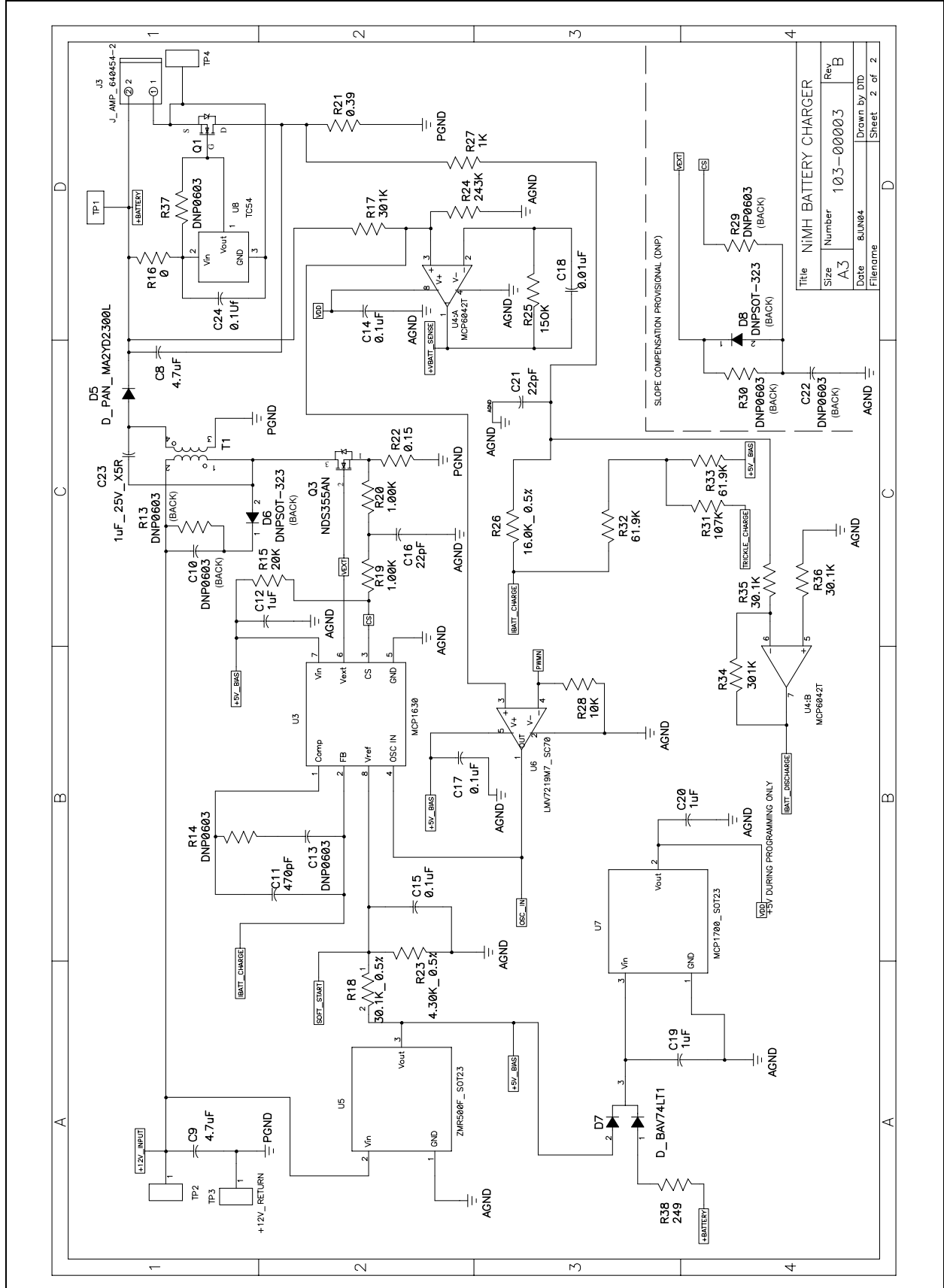

MCP1630 NiMH Battery Charger Demo Board User's Guide

A.4 BOARD - TOP LAYER

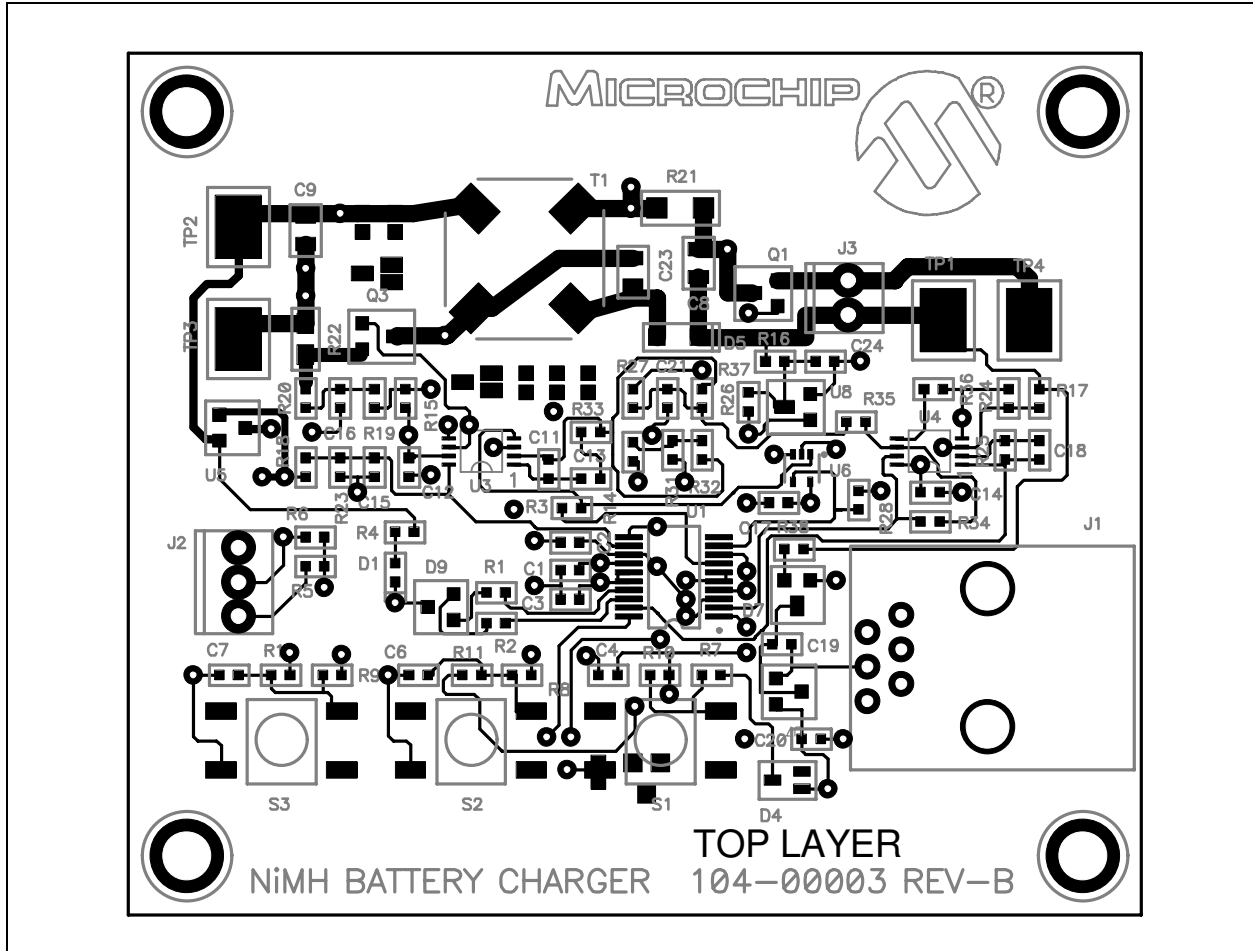

A.5 BOARD - BOTTOM LAYER

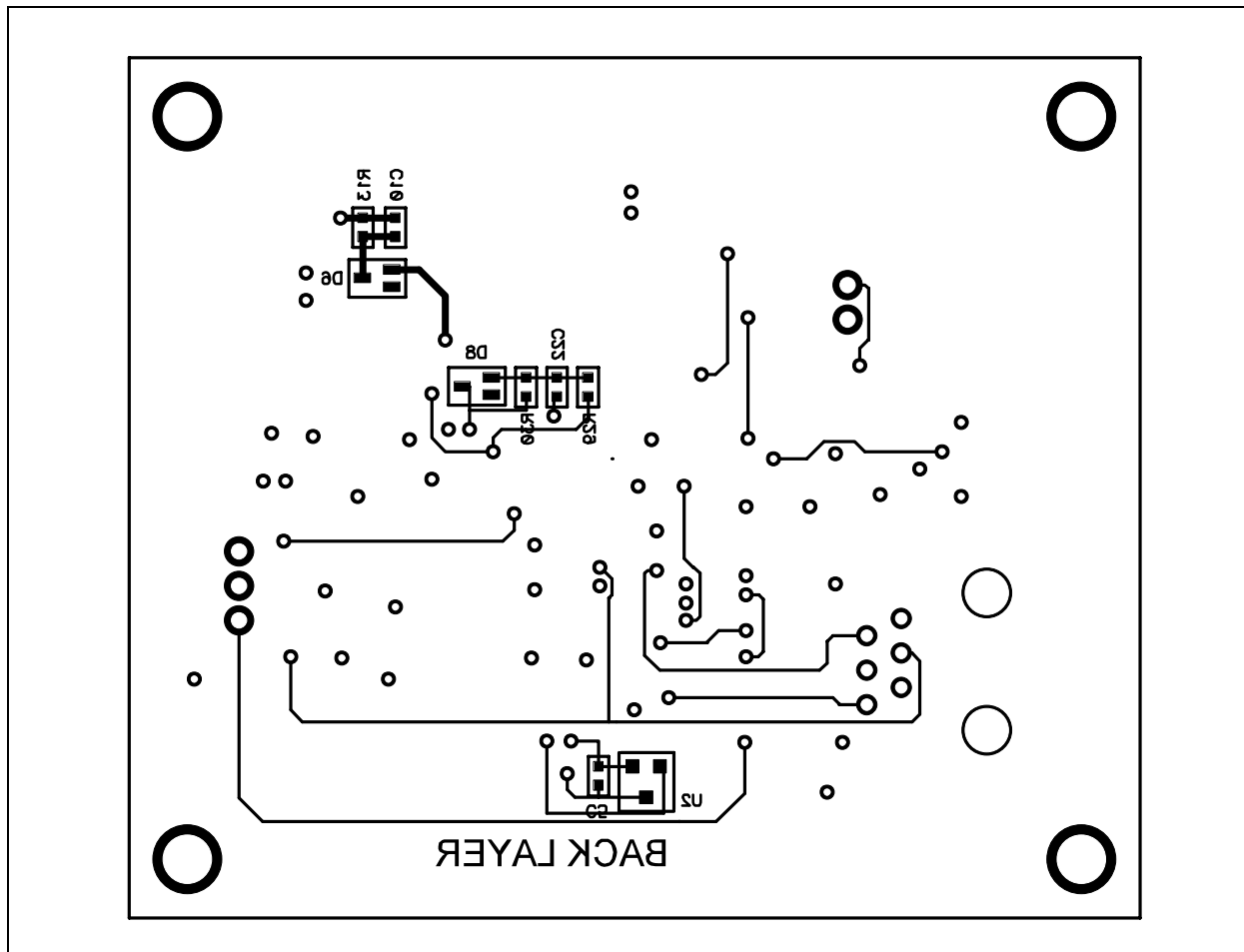

MCP1630 NiMH Battery Charger Demo Board User's Guide

A.6 BOARD - MID-LAYER 1

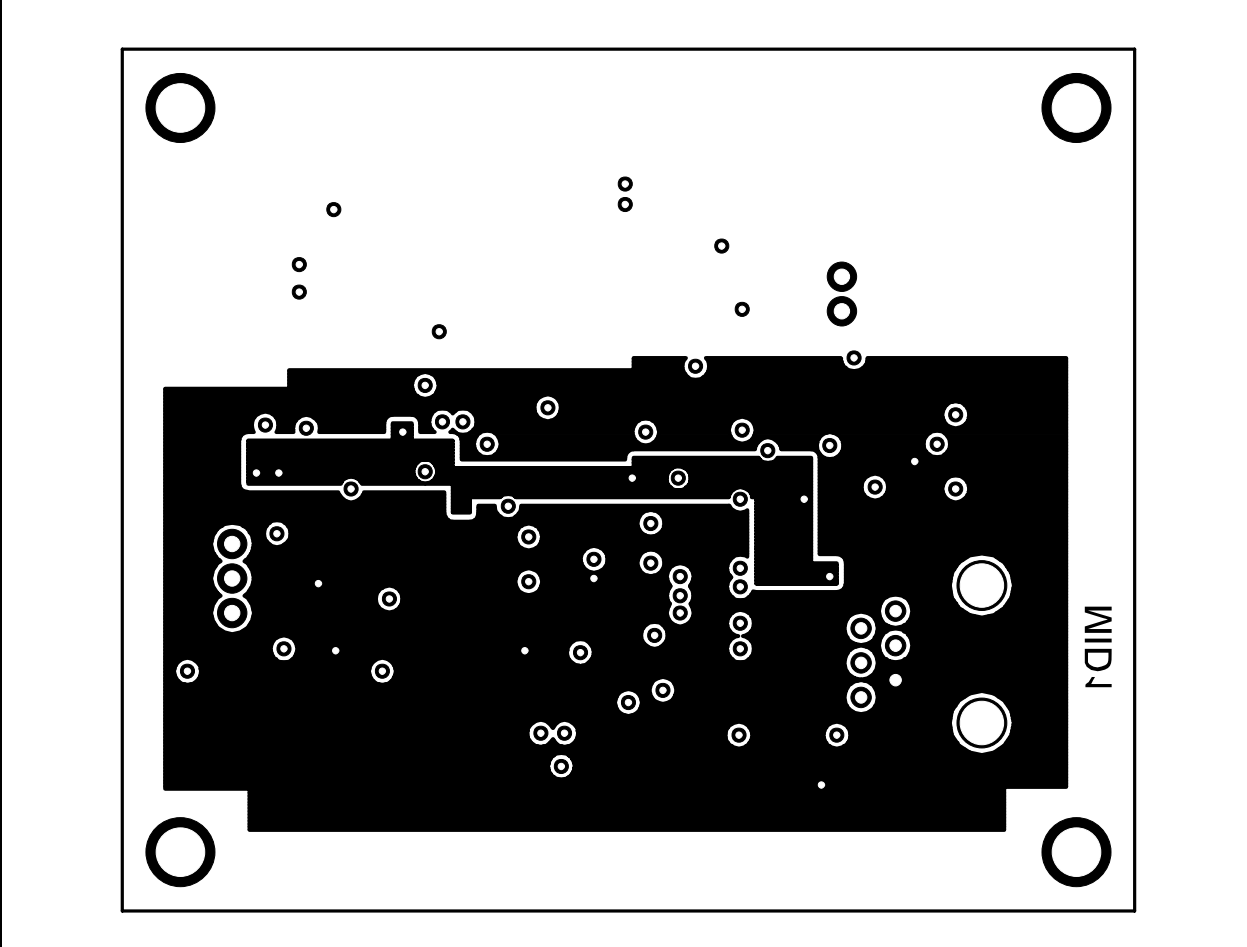

A.7 BOARD - MID-LAYER 2

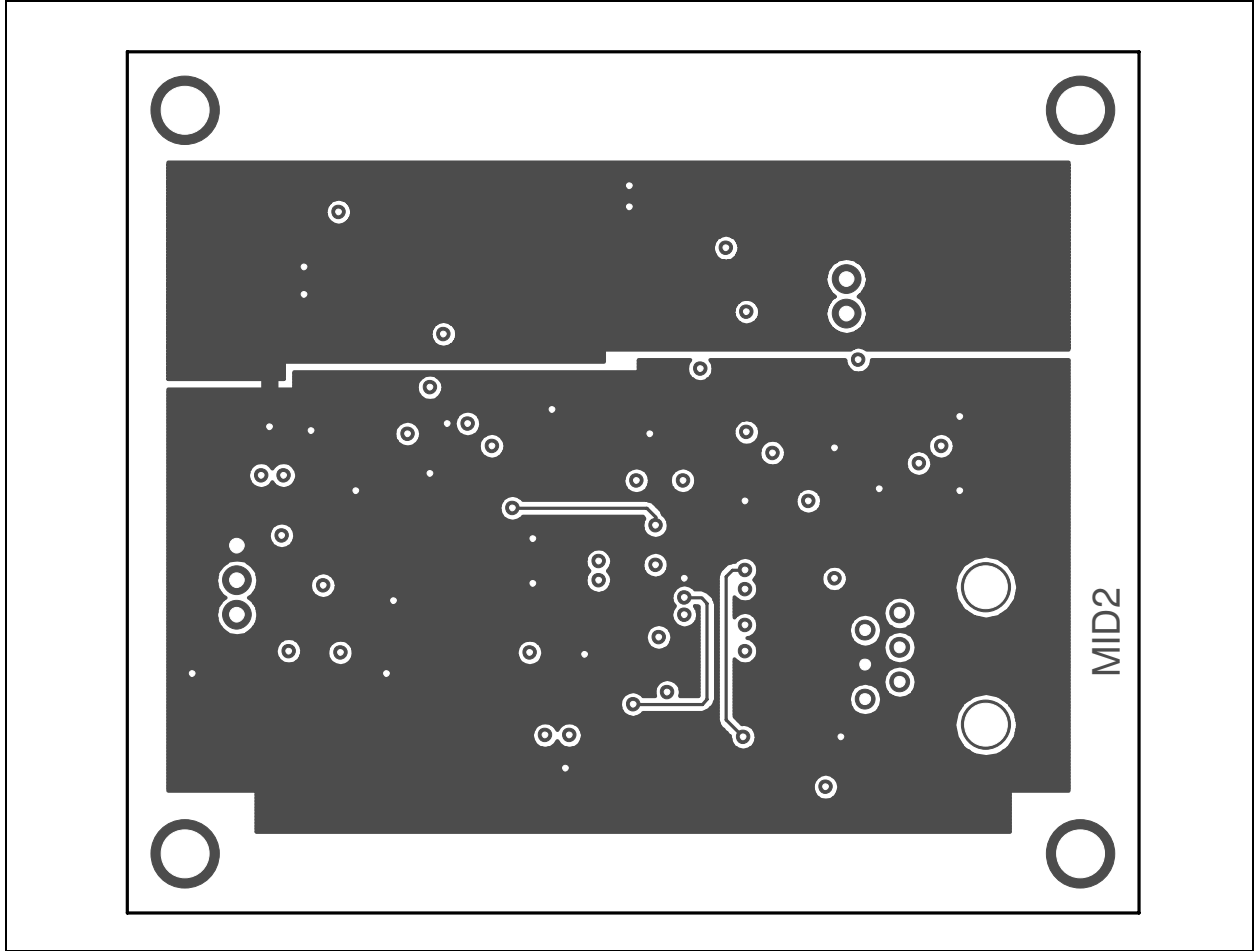

MCP1630 NiMH Battery Charger Demo Board User's Guide

NOTES:



MCP1630 NiMH BATTERY CHARGER DEMO BOARD USER'S GUIDE

Appendix B. Bill Of Materials (BOM)

TABLE B-1: BILL OF MATERIALS (BOM)

Qty	Reference	Description	Manufacturer	Part Number
6	C1, C2, C4, C10, C13, C22	"Do Not Populate" DNP0603	—	—
8	C3, C5, C6, C7, C14, C15, C17, C24	CAP .10UF 10V CERAMIC X7R 0603	Kemet® Electronics	C0603C104K8RACTU
2	C8, C9	CAP CERAMIC 4.7UF 16V X5R 0805	Panasonic® - ECG	ECJ-2FB1C475K
1	C11	CAP CERAMIC 470PF 50V NP0 0603	Panasonic - ECG	ECJ-1VC1H471J
3	C12, C19, C20	CAP CER 1.0UF 10V 10% X5R 0603	Murata Electronics® North America	GRM188R61A105KA61D
2	C16, C21	CAP CERAMIC 22PF 50V NP0 0603	Kemet Electronics	C0603C220J5GACTU
1	C18	CAP 10000PF 50V CERAMIC X7R 0603	Kemet Electronics	C0603C103K5RACTU
1	C23	CAP CERAMIC 1UF 25V X5R 0805	Panasonic - ECG	ECJ-2FB1E105K
1	D1	LED 660NM SUPER RED DIFF 0603SMD	Lumex® Opto/Components Inc.	SML-LX0603SRW-TR
1	D4	DIODE SWITCH 75V 200MW SOT-323	Diodes Inc.	BAS16W-7
1	D5	DIODE SCHOTTKY 25V 1.0A MINI-2P	Panasonic - SSG	MA2YD2300L
2	D6, D8	"Do Not Populate" SOT-323	—	—
1	D7	DIODE SWITCH DUAL CC 50V SOT-23	ON Semiconductor®	BAV74LT1
1	D9	LED DUAL RED/GREEN CLEAR SOT-23	Lumex Opto/Components Inc.	SML-LX15IGC-RP-TR
1	J1	CONN MOD JACK 6-6 R/A PCB 50AU	AMP®/Tyco® Electronics	5520470-3
1	J2	CONN HEADER VERT 3POS .100 TIN	AMP/Tyco Electronics	640454-3
1	J3	CONN HEADER VERT 2POS .100 TIN	AMP/Tyco Electronics	640454-2
1	Q1	HEX/MOS N-CH 20V 4.2A SOT-23	International Rectifier	IRLML2502TR
1	Q3	MOSFET N-CH 30V 1.7A 3-SSOT	Fairchild Semiconductor®	NDS355AN
2	R1, R2	RES 200 OHM 1/16W 1% 0603 SMD	Panasonic - ECG	ERJ-3EKF2000V
9	R3, R5, R6, R7, R8, R9, R10, R11, R12	RES 47.5K OHM 1/16W 1% 0603 SMD	Panasonic - ECG	ERJ-3EKF4752V
1	R4	RES 2.49K OHM 1/16W 1% 0603 SMD	Panasonic - ECG	ERJ-3EKF2491V
5	R13, R14, R29, R30, R37	"Do Not Populate" 0603	-	-
1	R15	RES 20K OHM 1/16W .1% 0603 SMD	Panasonic - ECG	ERA-3YEB203V
1	R16	RES ZERO OHM 1/10W 5% 0603 SMD	Panasonic - ECG	ERJ-3GEY0R00V
2	R17, R34	RES 301K OHM 1/16W 1% 0603 SMD	Panasonic - ECG	ERJ-3EKF3013V
3	R18, R35, R36	RES 30.1K OHM 1/16W 1% 0603 SMD	Panasonic - ECG	ERJ-3EKF3012V
3	R19, R20, R27	RES 1.00K OHM 1/16W 1% 0603 SMD	Panasonic - ECG	ERJ-3EKF1001V
1	R21	RES .39 OHM 1/4W 1% 1206 SMD	Panasonic - ECG	ERJ-8RQFR39V

MCP1630 NiMH Battery Charger Demo Board User's Guide

TABLE B-1: BILL OF MATERIALS (BOM) (CONTINUED)

Qty	Reference	Description	Manufacturer	Part Number
1	R22	RES .15 OHM 1/8W 5% 0805 SMD	Panasonic - ECG	ERJ-6RSJR15V
1	R23	RES 4.3K OHM 1/16W .5% 0603 SMD	Susumu Co Ltd	RR0816P-432-D
1	R24	RES 243K OHM 1/16W 1% 0603 SMD	Panasonic - ECG	ERJ-3EKF2433V
1	R25	RES 150K OHM 1/16W 1% 0603 SMD	Panasonic - ECG	ERJ-3EKF1503V
1	R26	RES 16.0K OHM 1/16W .5% 0603 SMD	Susumu Co Ltd	RR0816P-163-D
1	R28	RES 10.0K OHM 1/16W 1% 0603 SMD	Panasonic - ECG	ERJ-3EKF1002V
1	R31	RES 107K OHM 1/16W 1% 0603 SMD	Panasonic - ECG	ERJ-3EKF1073V
2	R32, R33	RES 61.9K OHM 1/16W 1% 0603 SMD	Panasonic - ECG	ERJ-3EKF6192V
1	R38	RES 249 OHM 1/16W 1% 0603 SMD	Panasonic - ECG	ERJ-3EKF2490V
3	S1, S2, S3	SWITCH TACT 6MM 260GF SMT	E-Switch, Inc.	TL3301NF260QG
1	T1	8th-PAK SMT Dual Inductor	BH Electronics®	L11-1016
4	TP1, TP2, TP3, TP4	PC TEST POINT COMPACT SMT	Keystone Electronics®	5016
1	U1	IC MCU FLASH 1KX14 EEPROM 20-SSOP	Microchip Technology, Inc.	PIC16LF818-I/SS
1	U2	IC TEMP-VOLT CONV PREC SOT-23B	Microchip Technology, Inc.	TC1047AVNBTR
1	U3	High-Speed PIC PWM MSOP8	Microchip Technology, Inc.	MCP1630-E/MS
1	U4	IC OPAMP 1UA 1.4V DUAL R-R 8MSOP	Microchip Technology, Inc.	MCP6042T-I/MS
1	U5	IC VREG MINI 5V 50MA SOT-23	Zetex Inc.	ZMR500FTA
1	U6	IC COMPARATOR R-R OUT SC-70-5	National Semiconductor®	LMV7219M7
1	U7	IC LDO REG 250MA 3.0V SOT-23	Microchip Technology, Inc.	MCP1700T-3002E/TT
1	U8	IC VOLT DETECTOR 2.9V SOT23A	Microchip Technology, Inc.	TC54VC2902ECB713

Appendix C. Evaluation Board Firmware

C.1 DEVICE FIRMWARE

For the latest version of the MCP1630 NiMH Battery Charger Demo Board User's Guide firmware, visit the Microchip web site at www.microchip.com.

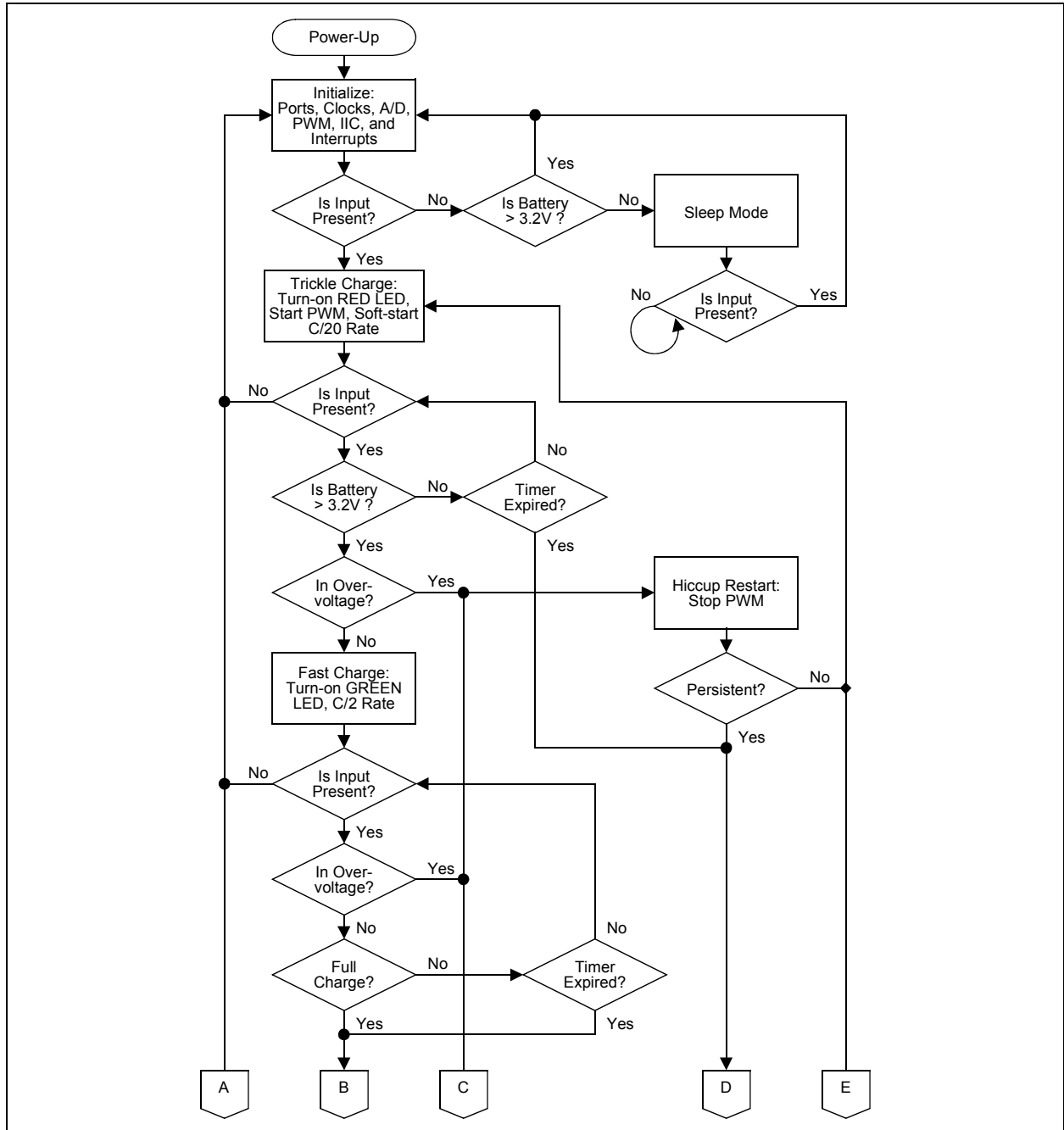

FIGURE C-1: Firmware Flowchart - Page 1.