



Chipsmall Limited consists of a professional team with an average of over 10 year of expertise in the distribution of electronic components. Based in Hongkong, we have already established firm and mutual-benefit business relationships with customers from,Europe,America and south Asia,supplying obsolete and hard-to-find components to meet their specific needs.

With the principle of “Quality Parts,Customers Priority,Honest Operation,and Considerate Service”,our business mainly focus on the distribution of electronic components. Line cards we deal with include Microchip,ALPS,ROHM,Xilinx,Pulse,ON,Everlight and Freescale. Main products comprise IC,Modules,Potentiometer,IC Socket,Relay,Connector.Our parts cover such applications as commercial,industrial, and automotives areas.

We are looking forward to setting up business relationship with you and hope to provide you with the best service and solution. Let us make a better world for our industry!



## Contact us

Tel: +86-755-8981 8866 Fax: +86-755-8427 6832

Email & Skype: info@chipsmall.com Web: www.chipsmall.com

Address: A1208, Overseas Decoration Building, #122 Zhenhua RD., Futian, Shenzhen, China



## Low-Power 12-Bit A/D Converter with I<sup>2</sup>C Interface

### Features

- 12-bit Resolution
- $\pm 1$  LSB DNL,  $\pm 2$  LSB INL maximum
- 250  $\mu$ A Max Conversion Current
- 5 nA Typical Standby Current, 1  $\mu$ A maximum
- I<sup>2</sup>C Compatible Serial Interface
  - 100 kHz I<sup>2</sup>C Standard mode
  - 400 kHz I<sup>2</sup>C Fast mode
- Up to 8 Devices on a Single 2-wire Bus
- 22.3 ksp/s in I<sup>2</sup>C Fast mode
- Single-Ended Analog Input Channel
- On-Chip Sample and Hold
- On-Chip Conversion Clock
- Single-Supply Specified Operation: 2.7V to 5.5V
- Temperature Range:
  - Extended: -40°C to +125°C
- Small SOT-23-5 package

### Applications

- Data Logging
- Multi-Zone Monitoring
- Handheld Portable Applications
- Battery-Powered Test Equipment
- Remote or Isolated Data Acquisition

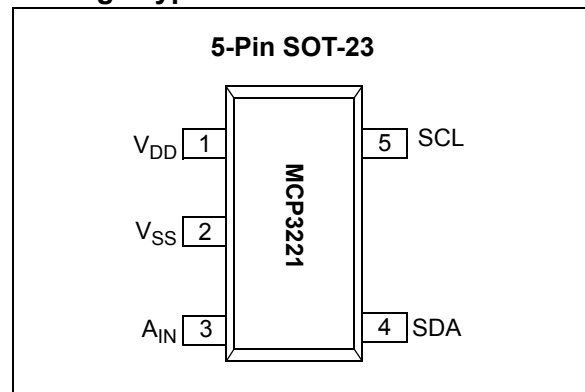
### General Description

Microchip's MCP3221 is a successive approximation A/D converter (ADC) with a 12-bit resolution. Available in the SOT-23 package, this device provides one single-ended input with very low-power consumption. Based on an advanced CMOS technology, the MCP3221 provides a low maximum conversion current and standby current of 250  $\mu$ A and 1  $\mu$ A, respectively. Low-current consumption, combined with the small SOT-23 package, make this device ideal for battery-powered and remote data acquisition applications.

Communication to the MCP3221 is performed using a 2-wire, I<sup>2</sup>C compatible interface. Standard (100 kHz) and Fast (400 kHz) I<sup>2</sup>C modes are available with the device. An on-chip conversion clock enables independent timing for the I<sup>2</sup>C and conversion clocks. The device is also addressable, allowing up to eight devices on a single 2-wire bus.

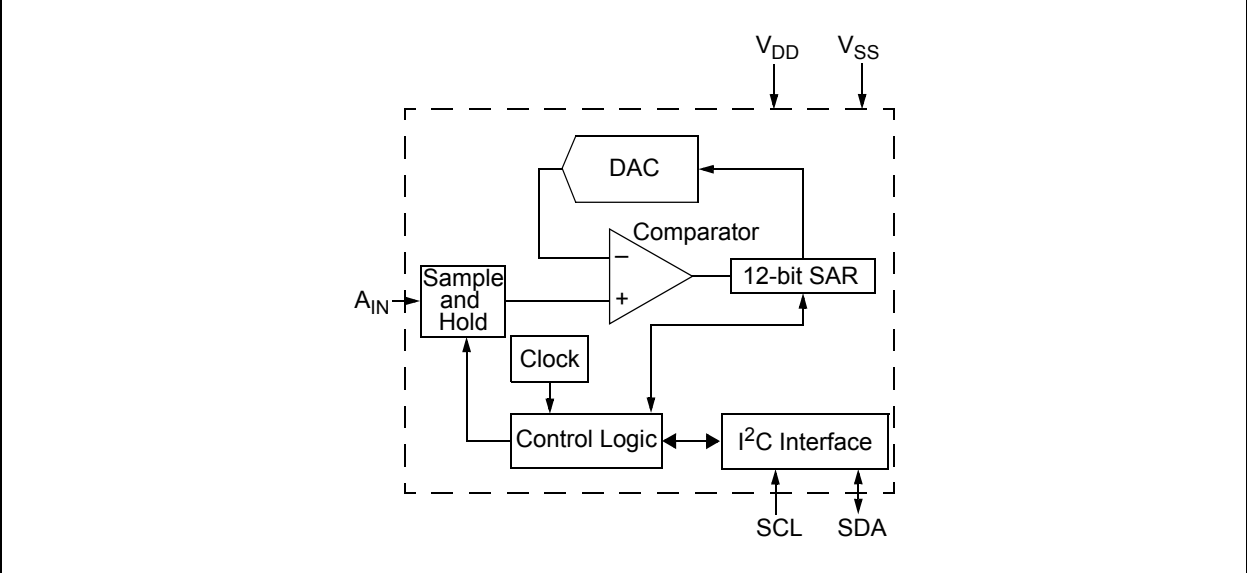
The MCP3221 runs on a single-supply voltage that operates over a broad range of 2.7V to 5.5V. This device also provides excellent linearity of  $\pm 1$  LSB differential nonlinearity (DNL) and  $\pm 2$  LSB integral nonlinearity (INL), maximum.

### Package Type



# MCP3221

## Functional Block Diagram



## 1.0 ELECTRICAL CHARACTERISTICS

### Absolute Maximum Ratings †

$V_{DD}$ .....	+7.0V
Analog input pin w.r.t. $V_{SS}$ .....	-0.6V to $V_{DD}$ +0.6V
SDA and SCL pins w.r.t. $V_{SS}$ .....	-0.6V to $V_{DD}$ +1.0V
Storage Temperature .....	-65°C to +150°C
Ambient Temperature with power applied.....	-65°C to +125°C
Maximum Junction Temperature.....	+150°C
ESD protection on all pins (HBM) .....	≥ 4 kV

† **Notice:** Stresses above those listed under “Absolute Maximum Ratings” may cause permanent damage to the device. This is a stress rating only and functional operation of the device at those or any other conditions above those indicated in the operational listings of this specification is not intended. Exposure to maximum rating conditions for extended periods may affect device reliability.

### DC ELECTRICAL SPECIFICATIONS

**Electrical Characteristics:** Unless otherwise noted, all parameters apply at  $V_{DD} = 5.0V$ ,  $V_{SS} = GND$ ,  $R_{PU} = 2\ k\Omega$ ,  $T_A = -40^\circ C$  to  $+85^\circ C$ , I<sup>2</sup>C Fast Mode Timing:  $f_{SCL} = 400\ kHz$  (**Note 3**).

Parameter	Sym.	Min.	Typ.	Max.	Units	Conditions
<b>DC Accuracy</b>						
Resolution	—	12			bits	
Integral Nonlinearity	INL	—	±0.75	±2	LSB	
Differential Nonlinearity	DNL	—	±0.5	±1	LSB	No missing codes
Offset Error	—	—	±0.75	±2	LSB	
Gain Error	—	—	-1	±3	LSB	
<b>Dynamic Performance</b>						
Total Harmonic Distortion	THD	—	-82	—	dB	$V_{IN} = 0.1V$ to $4.9V$ @ 1 kHz
Signal-to-Noise and Distortion	SINAD	—	72	—	dB	$V_{IN} = 0.1V$ to $4.9V$ @ 1 kHz
Spurious Free Dynamic Range	SFDR	—	86	—	dB	$V_{IN} = 0.1V$ to $4.9V$ @ 1 kHz
<b>Analog Input</b>						
Input Voltage Range	—	$V_{SS}-0.3$	—	$V_{DD}+0.3$	V	$2.7V \leq V_{DD} \leq 5.5V$
Leakage Current	—	-1	—	+1	µA	
<b>SDA/SCL (open-drain output)</b>						
Data Coding Format	—	Straight Binary			—	
High-Level Input Voltage	$V_{IH}$	$0.7 V_{DD}$	—	—	V	
Low-Level Input Voltage	$V_{IL}$	—	—	$0.3 V_{DD}$	V	
Low-Level Output Voltage	$V_{OL}$	—	—	0.4	V	$I_{OL} = 3\ mA$ , $R_{PU} = 1.53\ k\Omega$
Hysteresis of Schmitt Trigger Inputs	$V_{HYST}$	—	$0.05 V_{DD}$	—	V	$f_{SCL} = 400\ kHz$ only
Input Leakage Current	$I_{LI}$	-1	—	+1	µA	$V_{IN} = 0.1 V_{DD}$ and $0.9 V_{DD}$
Output Leakage Current	$I_{LO}$	-1	—	+1	µA	$V_{OUT} = 0.1 V_{SS}$ and $0.9 V_{DD}$

**Note 1:** Sample time is the time between conversions once the address byte has been sent to the converter. Refer to [Figure 5-6](#).

**2:** This parameter is periodically sampled and not 100% tested.

**3:**  $R_{PU}$  = Pull-up resistor on SDA and SCL.

**4:** SDA and SCL =  $V_{SS}$  to  $V_{DD}$  at 400 kHz.

**5:**  $t_{ACQ}$  and  $t_{CONV}$  are dependent on internal oscillator timing. See [Figure 5-5](#) and [Figure 5-6](#) in relation to SCL.

# MCP3221

## DC ELECTRICAL SPECIFICATIONS (CONTINUED)

<b>Electrical Characteristics:</b> Unless otherwise noted, all parameters apply at $V_{DD} = 5.0V$ , $V_{SS} = GND$ , $R_{PU} = 2\text{ k}\Omega$ , $T_A = -40^\circ\text{C}$ to $+85^\circ\text{C}$ , I <sup>2</sup> C Fast Mode Timing: $f_{SCL} = 400\text{ kHz}$ ( <b>Note 3</b> ).						
Parameter	Sym.	Min.	Typ.	Max.	Units	Conditions
Pin Capacitance (all inputs/outputs)	$C_{IN}$ , $C_{OUT}$	—	—	10	pF	$T_A = 25^\circ\text{C}$ , $f = 1\text{ MHz}$ ; ( <b>Note 2</b> )
Bus Capacitance	$C_B$	—	—	400	pF	SDA drive low, 0.4V
<b>Power Requirements</b>						
Operating Voltage	$V_{DD}$	2.7	—	5.5	V	
Conversion Current	$I_{DD}$	—	175	250	$\mu\text{A}$	
Standby Current	$I_{DDS}$	—	0.005	1	$\mu\text{A}$	SDA, SCL = $V_{DD}$
Active Bus Current	$I_{DDA}$	—	—	120	$\mu\text{A}$	<b>Note 4</b>
<b>Conversion Rate</b>						
Conversion Time	$t_{CONV}$	—	8.96	—	$\mu\text{s}$	<b>Note 5</b>
Analog Input Acquisition Time	$t_{ACQ}$	—	1.12	—	$\mu\text{s}$	<b>Note 5</b>
Sample Rate	$f_{SAMP}$	—	—	22.3	ksps	$f_{SCL} = 400\text{ kHz}$ ( <b>Note 1</b> )

- Note 1:** Sample time is the time between conversions once the address byte has been sent to the converter. Refer to [Figure 5-6](#).
- 2:** This parameter is periodically sampled and not 100% tested.
- 3:**  $R_{PU}$  = Pull-up resistor on SDA and SCL.
- 4:** SDA and SCL =  $V_{SS}$  to  $V_{DD}$  at 400 kHz.
- 5:**  $t_{ACQ}$  and  $t_{CONV}$  are dependent on internal oscillator timing. See [Figure 5-5](#) and [Figure 5-6](#) in relation to SCL.

## TEMPERATURE SPECIFICATIONS

<b>Electrical Characteristics:</b> Unless otherwise noted, all parameters apply at $V_{DD} = 5.0V$ , $V_{SS} = GND$ .						
Parameter	Sym.	Min.	Typ.	Max.	Units	Conditions
<b>Temperature Ranges</b>						
Operating Temperature Range	$T_A$	-40	—	+125	$^\circ\text{C}$	
Extended Temperature Range	$T_A$	-40	—	+125	$^\circ\text{C}$	
Storage Temperature Range	$T_A$	-65	—	+150	$^\circ\text{C}$	
<b>Thermal Package Resistances</b>						
Thermal Resistance, SOT-23	$\theta_{JA}$	—	256	—	$^\circ\text{C/W}$	

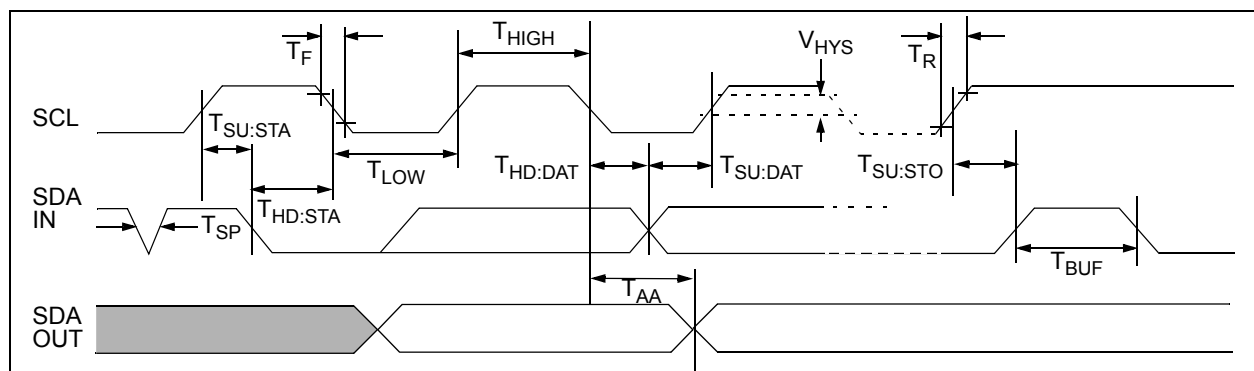
## TIMING SPECIFICATIONS

**Electrical Characteristics:** All parameters apply at  $V_{DD} = 2.7V - 5.5V$ ,  $V_{SS} = GND$ ,  $T_A = -40^{\circ}C$  to  $+85^{\circ}C$ .

Parameter	Sym.	Min.	Typ.	Max.	Units	Conditions
<b>I<sup>2</sup>C Standard Mode</b>						
Clock Frequency	$f_{SCL}$	0	—	100	kHz	
Clock High Time	$T_{HIGH}$	4000	—	—	ns	
Clock Low Time	$T_{LOW}$	4700	—	—	ns	
SDA and SCL Rise Time	$T_R$	—	—	1000	ns	From $V_{IL}$ to $V_{IH}$ (Note 1)
SDA and SCL Fall Time	$T_F$	—	—	300	ns	From $V_{IL}$ to $V_{IH}$ (Note 1)
Start Condition Hold Time	$T_{HD:STA}$	4000	—	—	ns	
Start Condition Setup Time	$T_{SU:STA}$	4700	—	—	ns	
Data Input Setup Time	$T_{SU:DAT}$	250	—	—	ns	
Stop Condition Setup Time	$T_{SU:STO}$	4000	—	—	ns	
Stop Condition Hold time	$T_{HD:STD}$	4000	—	—	ns	
Output Valid from Clock	$T_{AA}$	—	—	3500	ns	
Bus Free Time	$T_{BUF}$	4700	—	—	ns	Note 2
Input Filter Spike Suppression	$T_{SP}$	—	—	50	ns	SDA and SCL pins (Note 1)
<b>I<sup>2</sup>C Fast Mode</b>						
Clock Frequency	$F_{SCL}$	0	—	400	kHz	
Clock High Time	$T_{HIGH}$	600	—	—	ns	
Clock Low Time	$T_{LOW}$	1300	—	—	ns	
SDA and SCL Rise Time	$T_R$	$20 + 0.1C_B$	—	300	ns	From $V_{IL}$ to $V_{IH}$ (Note 1)
SDA and SCL Fall Time	$T_F$	$20 + 0.1C_B$	—	300	ns	From $V_{IL}$ to $V_{IH}$ (Note 1)
Start Condition Hold Time	$T_{HD:STA}$	600	—	—	ns	
Start Condition Setup Time	$T_{SU:STA}$	600	—	—	ns	
Data Input Hold Time	$T_{HD:DAT}$	0	—	0.9	ms	
Data Input Setup Time	$T_{SU:DAT}$	100	—	—	ns	
Stop Condition Setup Time	$T_{SU:STO}$	600	—	—	ns	
Stop Condition Hold Time	$T_{HD:STD}$	600	—	—	ns	
Output Valid from Clock	$T_{AA}$	—	—	900	ns	
Bus Free Time	$T_{BUF}$	1300	—	—	ns	Note 2
Input Filter Spike Suppression	$T_{SP}$	—	—	50	ns	SDA and SCL pins (Note 1)

**Note 1:** This parameter is periodically sampled and not 100% tested.

**2:** Time the bus must be free before a new transmission can start.



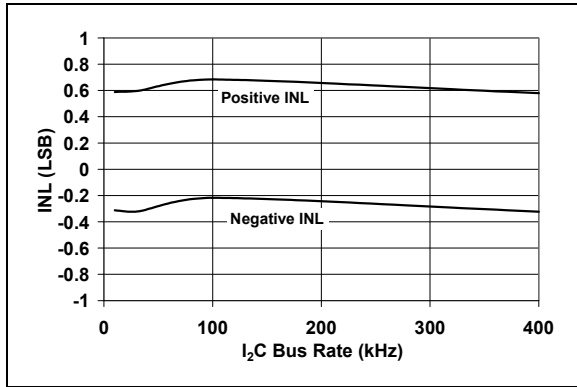
**FIGURE 1-1:** Standard and Fast Mode Bus Timing Data.

# MCP3221

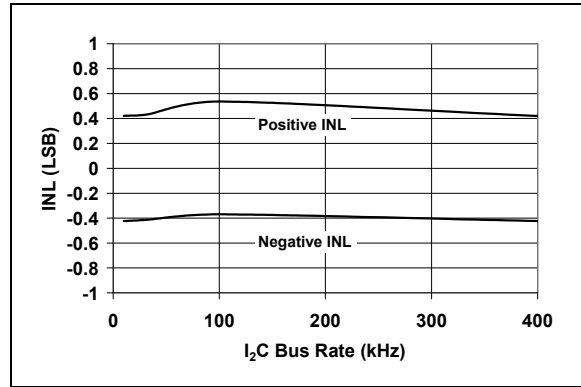
## 2.0 TYPICAL PERFORMANCE CURVES

**Note:** The graphs and tables provided following this note are a statistical summary based on a limited number of samples and are provided for informational purposes only. The performance characteristics listed herein are not tested or guaranteed. In some graphs or tables, the data presented may be outside the specified operating range (e.g., outside specified power supply range) and therefore outside the warranted range.

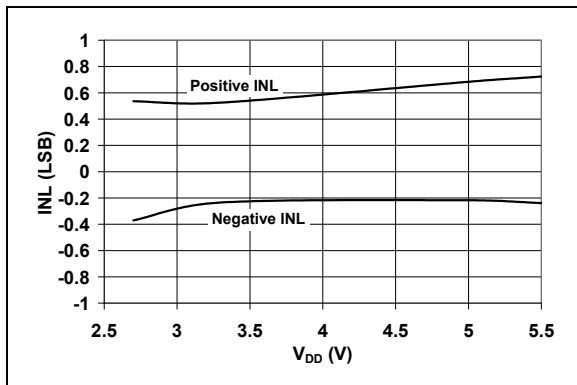
**Note:** Unless otherwise indicated,  $V_{DD} = 5V$ ,  $V_{SS} = 0V$ , I<sup>2</sup>C Fast Mode Timing (SCL = 400 kHz), Continuous Conversion Mode ( $f_{SAMP} = 22.3$  ksp/s),  $T_A = +25^{\circ}C$ .



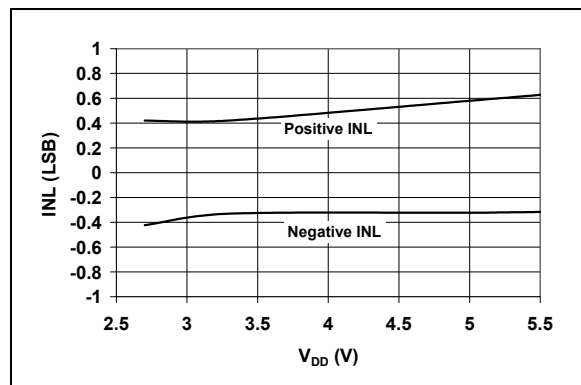
**FIGURE 2-1:** INL vs. Clock Rate.



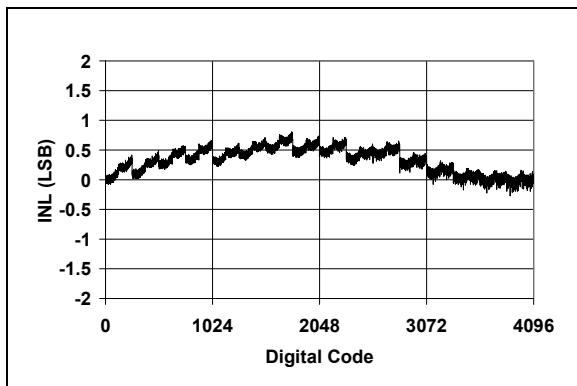
**FIGURE 2-4:** INL vs. Clock Rate ( $V_{DD} = 2.7V$ ).



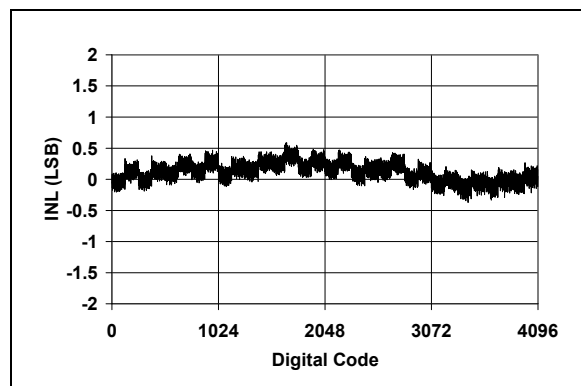
**FIGURE 2-2:** INL vs.  $V_{DD}$  - I<sup>2</sup>C Standard Mode ( $f_{SCL} = 100$  kHz).



**FIGURE 2-5:** INL vs.  $V_{DD}$  - I<sup>2</sup>C Fast Mode ( $f_{SCL} = 400$  kHz).

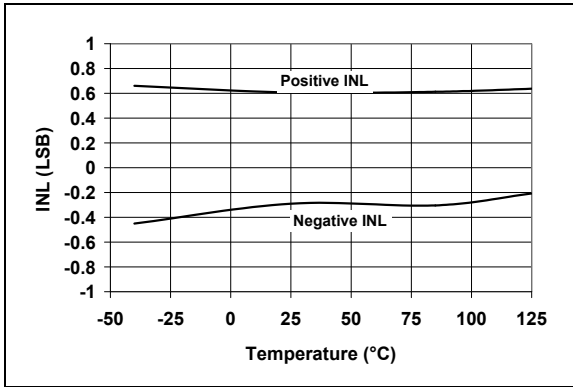


**FIGURE 2-3:** INL vs. Code (Representative Part).

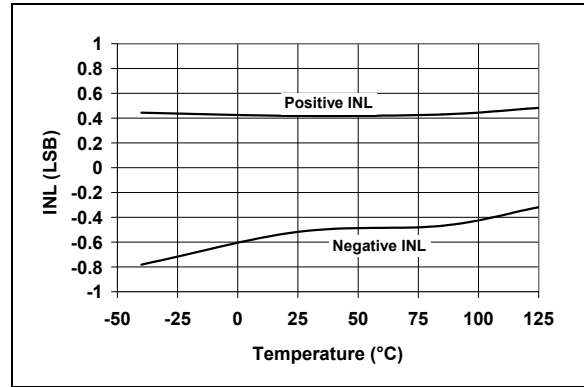


**FIGURE 2-6:** INL vs. Code (Representative Part,  $V_{DD} = 2.7V$ ).

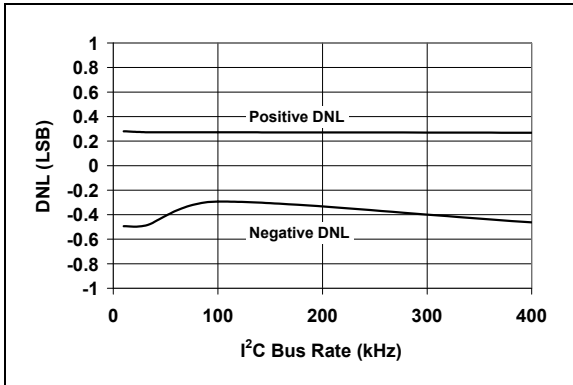
**Note:** Unless otherwise indicated,  $V_{DD} = 5V$ ,  $V_{SS} = 0V$ , I<sup>2</sup>C Fast Mode Timing (SCL = 400 kHz), Continuous Conversion Mode ( $f_{SAMP} = 22.3$  ksp/s),  $T_A = +25^{\circ}C$ .



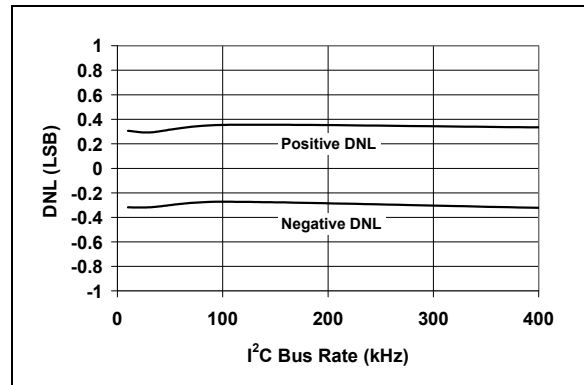
**FIGURE 2-7:** INL vs. Temperature.



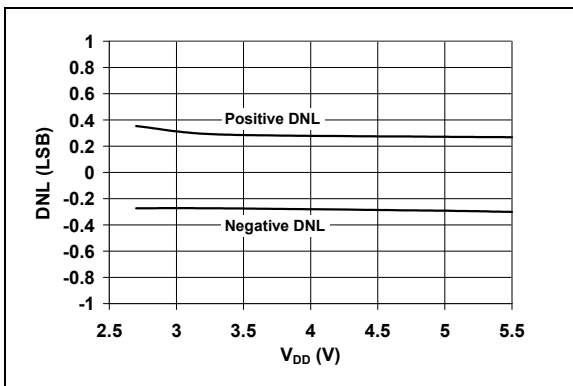
**FIGURE 2-10:** INL vs. Temperature ( $V_{DD} = 2.7V$ ).



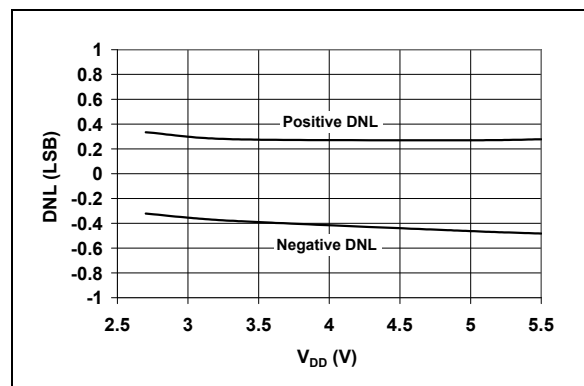
**FIGURE 2-8:** DNL vs. Clock Rate.



**FIGURE 2-11:** DNL vs. Clock Rate ( $V_{DD} = 2.7V$ ).



**FIGURE 2-9:** DNL vs.  $V_{DD}$  - I<sup>2</sup>C Standard Mode ( $f_{SCL} = 100$  kHz).

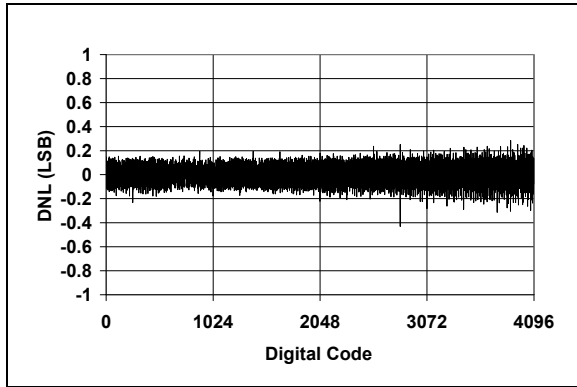


**FIGURE 2-12:** DNL vs.  $V_{DD}$  - I<sup>2</sup>C Fast Mode ( $f_{SCL} = 400$  kHz).

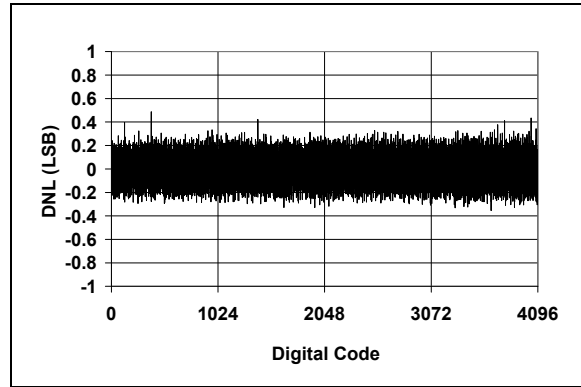


# MCP3221

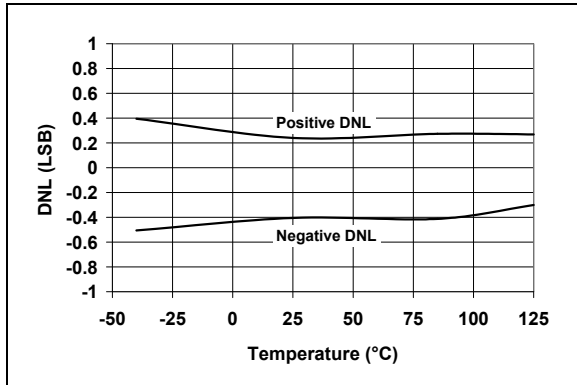
**Note:** Unless otherwise indicated,  $V_{DD} = 5V$ ,  $V_{SS} = 0V$ , I<sup>2</sup>C Fast Mode Timing (SCL = 400 kHz), Continuous Conversion Mode ( $f_{SAMP} = 22.3$  kps),  $T_A = +25^\circ C$ .



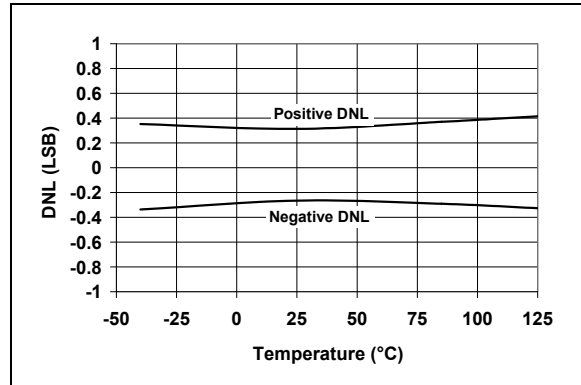
**FIGURE 2-13:** DNL vs. Code (Representative Part).



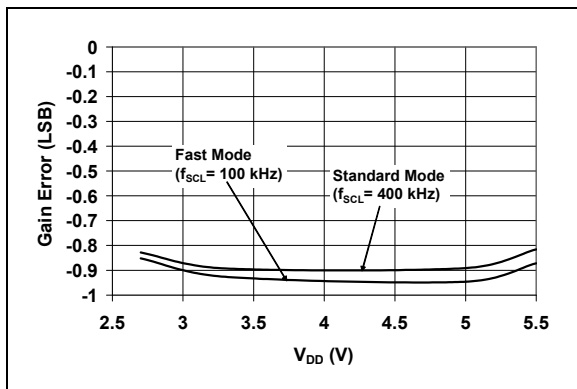
**FIGURE 2-16:** DNL vs. Code (Representative Part,  $V_{DD} = 2.7V$ ).



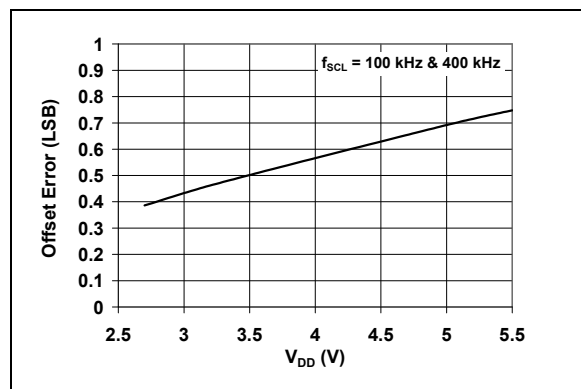
**FIGURE 2-14:** DNL vs. Temperature.



**FIGURE 2-17:** DNL vs. Temperature ( $V_{DD} = 2.7V$ ).

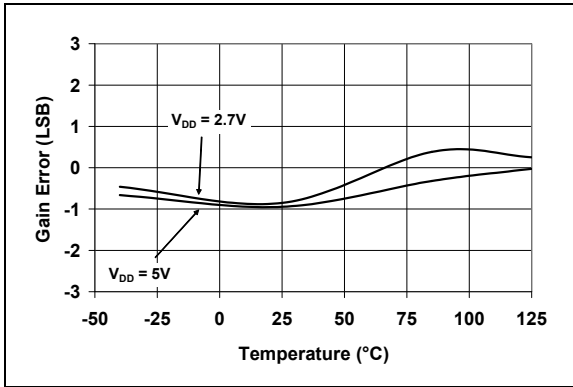


**FIGURE 2-15:** Gain Error vs.  $V_{DD}$ .

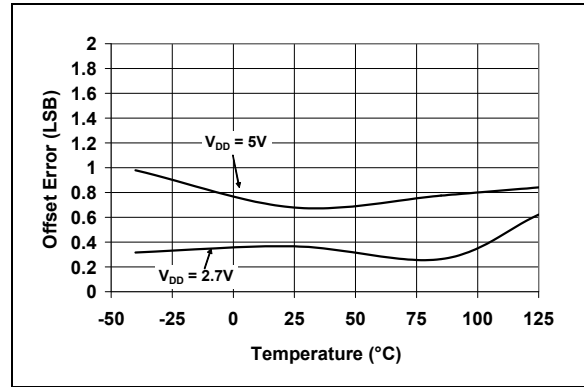


**FIGURE 2-18:** Offset Error vs.  $V_{DD}$ .

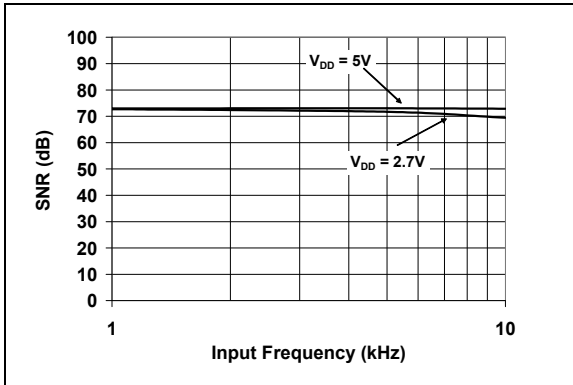
**Note:** Unless otherwise indicated,  $V_{DD} = 5V$ ,  $V_{SS} = 0V$ , I<sup>2</sup>C Fast Mode Timing (SCL = 400 kHz), Continuous Conversion Mode ( $f_{SAMP} = 22.3$  ksp/s),  $T_A = +25^\circ C$ .



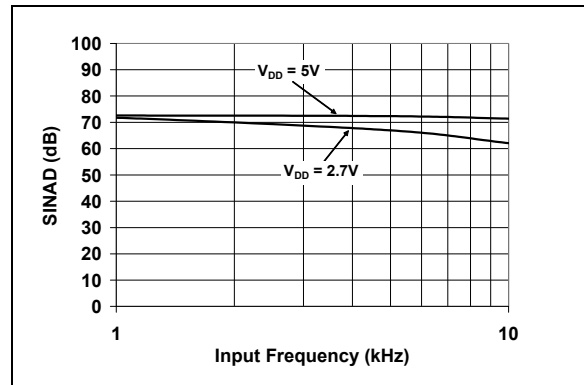
**FIGURE 2-19:** Gain Error vs. Temperature.



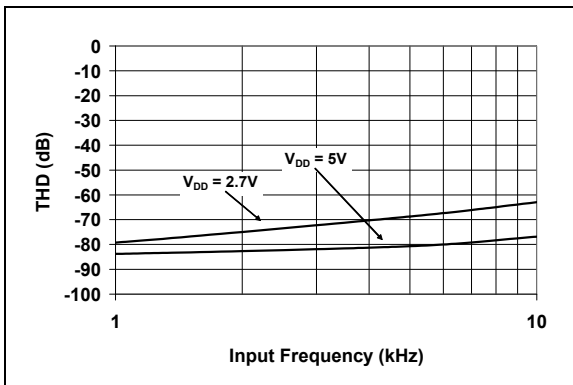
**FIGURE 2-22:** Offset Error vs. Temperature.



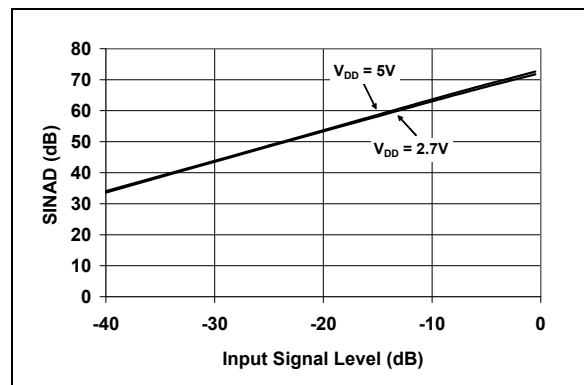
**FIGURE 2-20:** SNR vs. Input Frequency.



**FIGURE 2-23:** SINAD vs. Input Frequency.



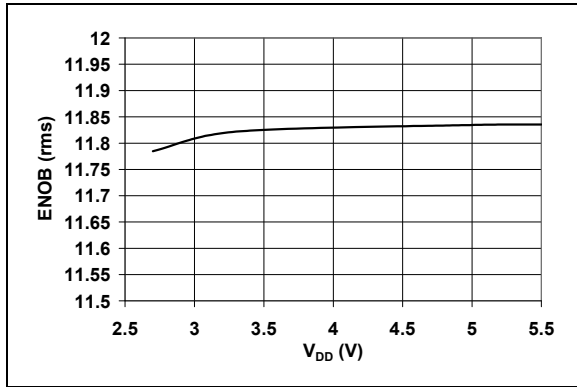
**FIGURE 2-21:** THD vs. Input Frequency.



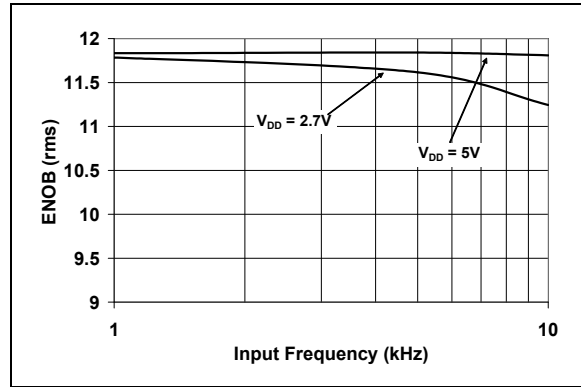
**FIGURE 2-24:** SINAD vs. Input Signal Level.

# MCP3221

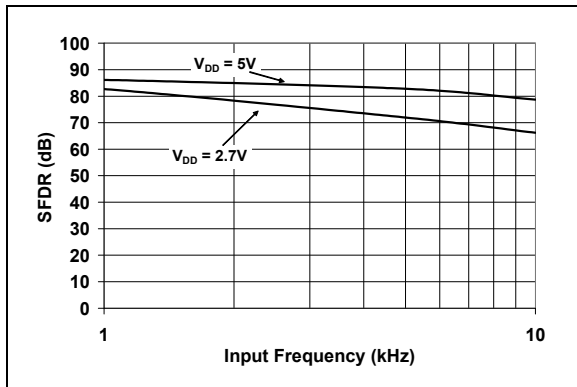
**Note:** Unless otherwise indicated,  $V_{DD} = 5V$ ,  $V_{SS} = 0V$ , I<sup>2</sup>C Fast Mode Timing (SCL = 400 kHz), Continuous Conversion Mode ( $f_{SAMP} = 22.3$  kpsps),  $T_A = +25^{\circ}C$ .



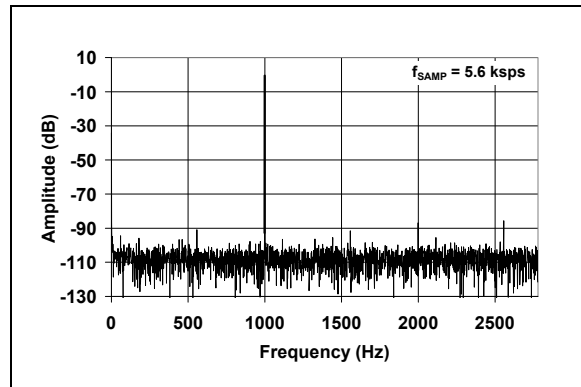
**FIGURE 2-25:** ENOB vs.  $V_{DD}$ .



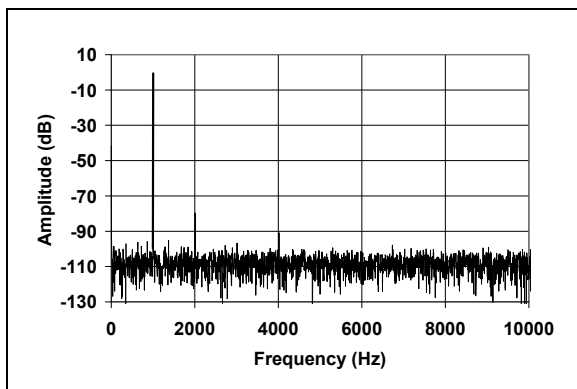
**FIGURE 2-28:** ENOB vs. Input Frequency.



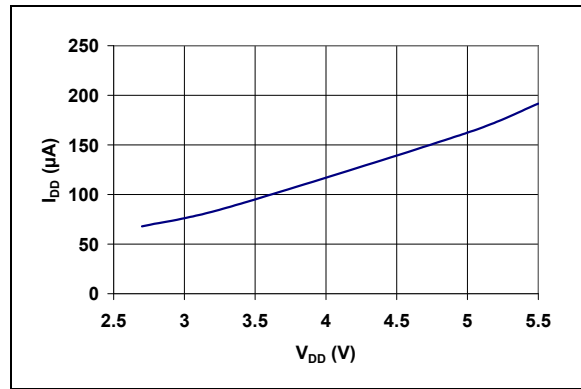
**FIGURE 2-26:** SFDR vs. Input Frequency.



**FIGURE 2-29:** Spectrum Using I<sup>2</sup>C Standard Mode (Representative Part, 1 kHz Input Frequency).

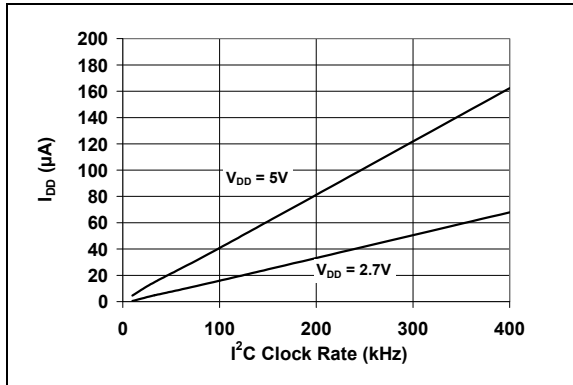


**FIGURE 2-27:** Spectrum Using I<sup>2</sup>C Fast Mode (Representative Part, 1 kHz Input Frequency).

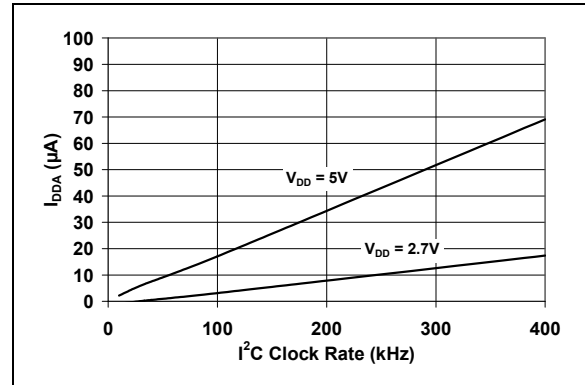


**FIGURE 2-30:**  $I_{DD}$  (Conversion) vs.  $V_{DD}$ .

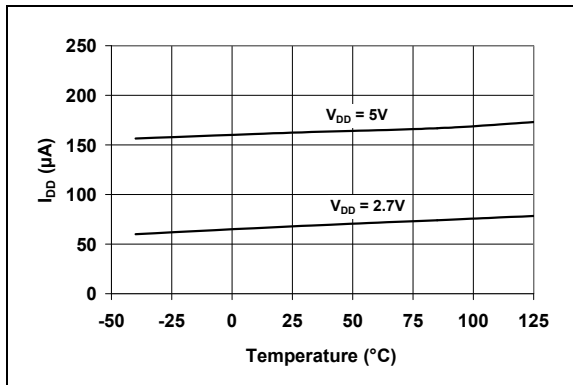
**Note:** Unless otherwise indicated,  $V_{DD} = 5V$ ,  $V_{SS} = 0V$ , I<sup>2</sup>C Fast Mode Timing (SCL = 400 kHz), Continuous Conversion Mode ( $f_{SAMP} = 22.3$  ksp/s),  $T_A = +25^\circ C$ .



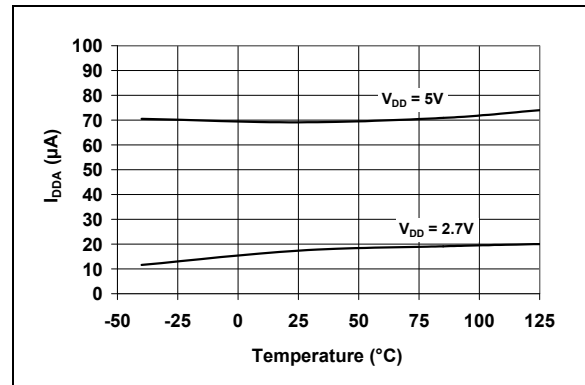
**FIGURE 2-31:**  $I_{DD}$  (Conversion) vs. Clock Rate.



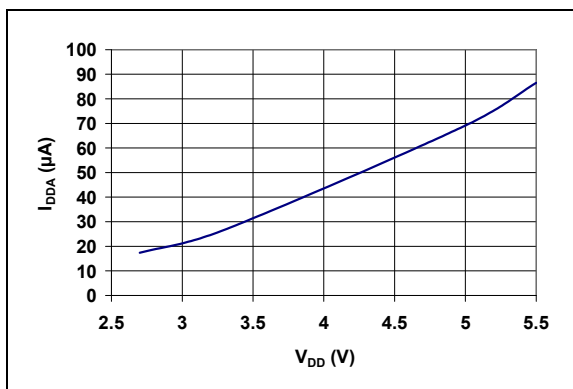
**FIGURE 2-34:**  $I_{DDA}$  (Active Bus) vs. Clock Rate.



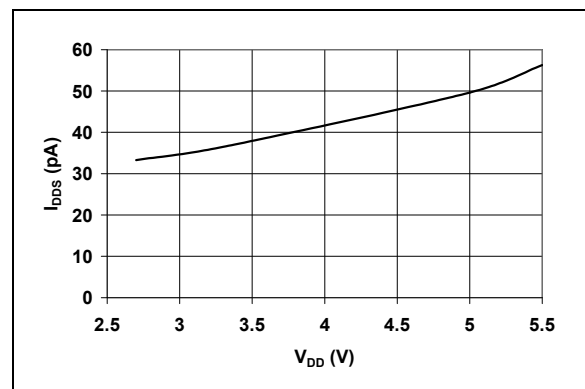
**FIGURE 2-32:**  $I_{DD}$  (Conversion) vs. Temperature.



**FIGURE 2-35:**  $I_{DDA}$  (Active Bus) vs. Temperature.



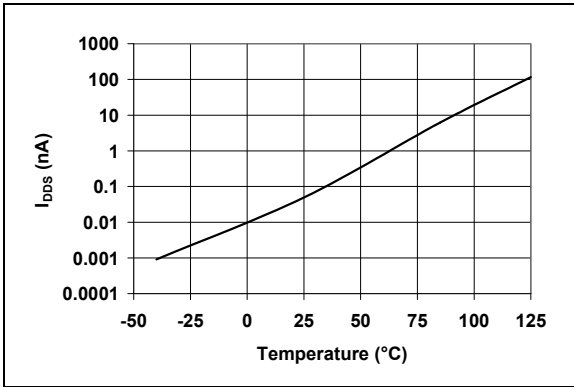
**FIGURE 2-33:**  $I_{DDA}$  (Active Bus) vs.  $V_{DD}$ .



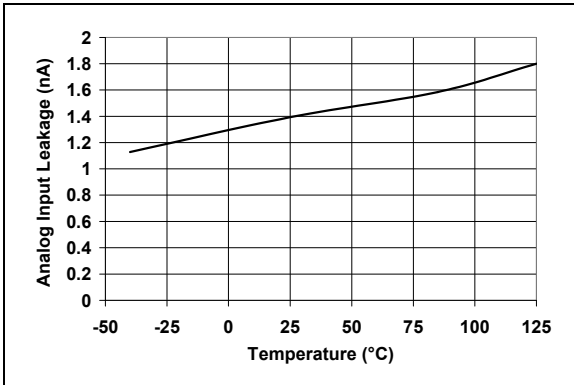
**FIGURE 2-36:**  $I_{DDS}$  (Standby) vs.  $V_{DD}$ .

# MCP3221

**Note:** Unless otherwise indicated,  $V_{DD} = 5V$ ,  $V_{SS} = 0V$ , I<sup>2</sup>C Fast Mode Timing (SCL = 400 kHz), Continuous Conversion Mode ( $f_{SAMP} = 22.3$  ksp/s),  $T_A = +25^\circ C$ .

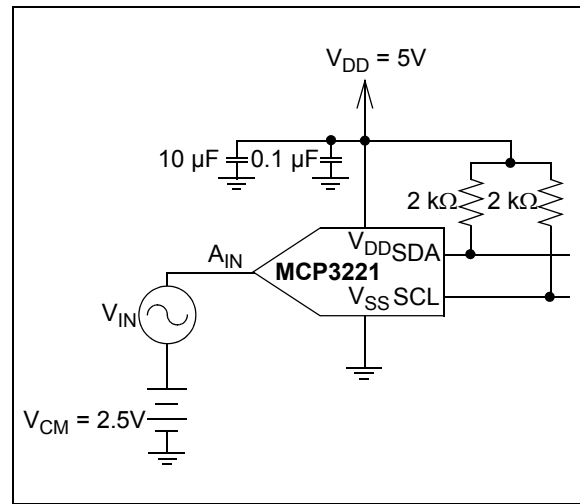


**FIGURE 2-37:**  $I_{DDS}$  (Standby) vs. Temperature.



**FIGURE 2-38:** Analog Input Leakage vs. Temperature.

## 2.1 Test Circuits



**FIGURE 2-39:** Typical Test Configuration.

### 3.0 PIN FUNCTIONS

Table 3-1 lists the function of the pins.

**TABLE 3-1: PIN FUNCTION TABLE**

Name	Function
$V_{DD}$	+2.7V to 5.5V Power Supply
$V_{SS}$	Ground
$A_{IN}$	Analog Input
SDA	Serial Data In/Out
SCL	Serial Clock In

#### 3.1 $V_{DD}$ and $V_{SS}$

The  $V_{DD}$  pin, with respect to  $V_{SS}$ , provides power to the device as well as a voltage reference for the conversion process. Refer to [Section 6.4 “Device Power and Layout Considerations”](#) for tips on power and grounding.

#### 3.2 Analog Input ( $A_{IN}$ )

$A_{IN}$  is the input pin to the sample and hold circuitry of the Successive Approximation Register (SAR) converter. Care should be taken in driving this pin. Refer to [Section 6.1 “Driving the Analog Input”](#) for more information. For proper conversions, the voltage on this pin can vary from  $V_{SS}$  to  $V_{DD}$ .

#### 3.3 Serial Data (SDA)

SDA is a bidirectional pin used to transfer addresses and data into and out of the device. It is an open-drain terminal, therefore, the SDA bus requires a pull-up resistor to  $V_{DD}$  (typically 10 k $\Omega$  for 100 kHz and 2 k $\Omega$  for 400 kHz SCL clock speeds). Refer to [Section 6.2 “Connecting to the I<sup>2</sup>C Bus”](#) for more information.

For normal data transfer, SDA is allowed to change only during SCL low. Changes during SCL high are reserved for indicating the Start and Stop conditions. Refer to [Section 5.1 “I<sup>2</sup>C Bus Characteristics”](#) for more information.

#### 3.4 Serial Clock (SCL)

SCL is an input pin used to synchronize the data transfer to and from the device on the SDA pin and is an open-drain terminal. Therefore, the SCL bus requires a pull-up resistor to  $V_{DD}$  (typically 10 k $\Omega$  for 100 kHz and 2 k $\Omega$  for 400 kHz SCL clock speeds). Refer to [Section 6.2 “Connecting to the I<sup>2</sup>C Bus”](#) for more information.

For normal data transfer, SDA is allowed to change only during SCL low. Changes during SCL high are reserved for indicating the Start and Stop conditions. Refer to [Section 6.1 “Driving the Analog Input”](#) for more information.

# MCP3221

## 4.0 DEVICE OPERATION

The MCP3221 employs a classic SAR architecture. This architecture uses an internal sample and hold capacitor to store the analog input while the conversion is taking place. At the end of the acquisition time, the input switch of the converter opens and the device uses the collected charge on the internal sample and hold capacitor to produce a serial 12-bit digital output code. The acquisition time and conversion is self-timed using an internal clock. After each conversion, the results are stored in a 12-bit register that can be read at any time.

Communication with the device is accomplished with a 2-wire, I<sup>2</sup>C interface. Maximum sample rates of 22.3 ksp/s are possible with the MCP3221 in a continuous-conversion mode and an SCL clock rate of 400 kHz.

### 4.1 Digital Output Code

The digital output code produced by the MCP3221 is a function of the input signal and power supply voltage, V<sub>DD</sub>. As the V<sub>DD</sub> level is reduced, the LSB size is reduced accordingly. The theoretical LSB size is shown below.

#### EQUATION

$$LSB\ SIZE = \frac{V_{DD}}{4096}$$

V<sub>DD</sub> = Supply voltage

The output code of the MCP3221 is transmitted serially with MSB first. The format of the code is straight binary.

### 4.2 Conversion Time (t<sub>CONV</sub>)

The conversion time is the time required to obtain the digital result once the analog input is disconnected from the holding capacitor. With the MCP3221, the specified conversion time is typically 8.96 μs. This time is dependent on the internal oscillator and is independent of SCL.

### 4.3 Acquisition Time (t<sub>ACQ</sub>)

The acquisition time is the amount of time the sample cap array is acquiring charge.

The acquisition time is, typically, 1.12 μs. This time is dependent on the internal oscillator and independent of SCL.

### 4.4 Sample Rate

Sample rate is the inverse of the maximum amount of time that is required from the point of acquisition of the first conversion to the point of acquisition of the second conversion.

The sample rate can be measured either by single or continuous conversions. A single conversion includes a Start bit, Address byte, two data bytes and a Stop bit. This sample rate is measured from one Start bit to the next Start bit.

For continuous conversions (requested by the Master by issuing an Acknowledge after a conversion), the maximum sample rate is measured from conversion to conversion or a total of 18 clocks (two data bytes and two Acknowledge bits). Refer to [Section 5.2 "Device Addressing"](#) for more information.

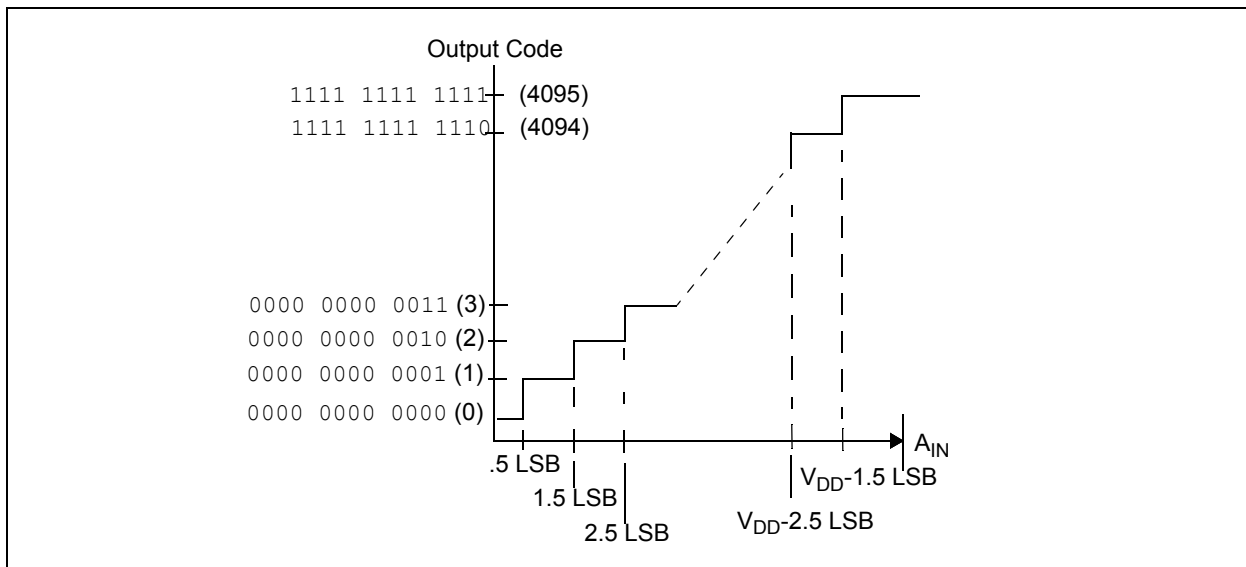


FIGURE 4-1: Transfer Function.

## 4.5 Differential Non-Linearity (DNL)

In the ideal A/D converter transfer function, each code has a uniform width. That is, the difference in analog input voltage is constant from one code transition point to the next. Differential nonlinearity (DNL) specifies the deviation of any code in the transfer function from an ideal code width of 1 LSB. The DNL is determined by subtracting the locations of successive code transition points after compensating for any gain and offset errors. A positive DNL implies that a code is longer than the ideal code width, whereas a negative DNL implies that a code is shorter than the ideal width.

## 4.6 Integral Non-Linearity (INL)

Integral nonlinearity (INL) is a result of cumulative DNL errors and specifies how much the overall transfer function deviates from a linear response. The method of measurement used in the MCP3221 A/D converter to determine INL is the end-point method.

## 4.7 Offset Error

Offset error is defined as a deviation of the code transition points that are present across all output codes. This has the effect of shifting the entire A/D transfer function. The offset error is measured by finding the difference between the actual location of the first code transition and the desired location of the first transition. The ideal location of the first code transition is located at 1/2 LSB above  $V_{SS}$ .

## 4.8 Gain Error

Gain error determines the amount of deviation from the ideal slope of the A/D converter transfer function. Before the gain error is determined, the offset error is measured and subtracted from the conversion result. The gain error can then be determined by finding the location of the last code transition and comparing that location to the ideal location. The ideal location of the last code transition is 1.5 LSBs below full-scale or  $V_{DD}$ .

## 4.9 Conversion Current ( $I_{DD}$ )

Conversion current is the average amount of current over the time required to perform a 12-bit conversion.

## 4.10 Active Bus Current ( $I_{DDA}$ )

The average amount of current over the time required to monitor the I<sup>2</sup>C bus. Any current that the device consumes while it is not being addressed is referred to as Active Bus current.

## 4.11 Standby Current ( $I_{DDs}$ )

The average amount of current required while no conversion is occurring and no data is being output (i.e., SCL and SDA lines are quiet).

## 4.12 I<sup>2</sup>C Standard Mode Timing

I<sup>2</sup>C specification where the frequency of SCL is 100 kHz.

## 4.13 I<sup>2</sup>C Fast Mode Timing

I<sup>2</sup>C specification where the frequency of SCL is 400 kHz.



# MCP3221

## 5.0 SERIAL COMMUNICATIONS

### 5.1 I<sup>2</sup>C Bus Characteristics

The following bus protocol are defined:

- Data transfer may be initiated only when the bus is not busy.
- During data transfer, the data line must remain stable whenever the clock line is high. Changes in the data line while the clock line is high will be interpreted as a Start or Stop condition.

Accordingly, the following bus conditions are defined (refer to [Figure 5-1](#)).

#### 5.1.1 BUS NOT BUSY (A)

Both data and clock lines remain high.

#### 5.1.2 START DATA TRANSFER (B)

A high-to-low transition of the SDA line while the clock (SCL) is high determines a Start condition. All commands must be preceded by a Start condition.

#### 5.1.3 STOP DATA TRANSFER (C)

A low-to-high transition of the SDA line while the clock (SCL) is high determines a Stop condition. All operations must be ended with a Stop condition.

#### 5.1.4 DATA VALID (D)

The state of the data line represents valid data when after a START condition, the data line is stable for the duration of the high period of the clock signal.

The data on the line must be changed during the low period of the clock signal. There is one clock pulse per bit of data.

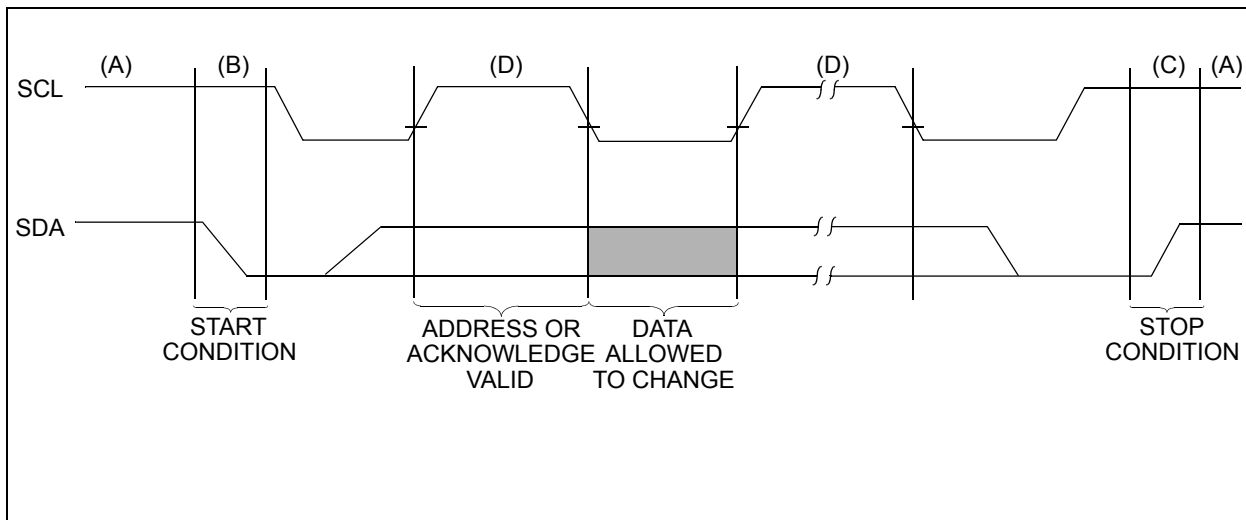
Each data transfer is initiated with a Start condition and terminated with a Stop condition. The number of data bytes being transferred between the Start and Stop conditions is determined by the master device and is unlimited.

#### 5.1.5 ACKNOWLEDGE

Each receiving device, when addressed, is obliged to generate an Acknowledge bit after the reception of each byte. The master device must generate an extra clock pulse that is associated with this Acknowledge bit.

The device that acknowledges has to pull down the SDA line during the acknowledge clock pulse in such a way that the SDA line is stable low during the high period of the acknowledge-related clock pulse. Setup and hold times must be taken into account. During reads, a master device must signal an end of data to the slave by not generating an Acknowledge bit on the last byte that is clocked out of the slave (NAK). In this case, the slave (MCP3221) releases the bus to allow the master device to generate the Stop condition.

The MCP3221 supports a bidirectional, 2-wire bus and data transmission protocol. The device that sends data onto the bus is the transmitter and the device receiving data is the receiver. The bus has to be controlled by a master device that generates the serial clock (SCL), controls the bus access and generates the Start and Stop conditions, whereas the MCP3221 works as a slave device. Both master and slave devices can operate as either transmitter or receiver, but the master device determines which mode is activated.



**FIGURE 5-1:** Data Transfer Sequence on the Serial Bus.

## 5.2 Device Addressing

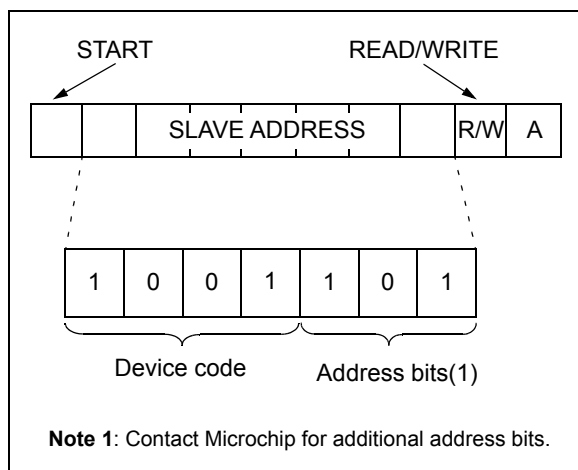
The address byte is the first byte received following the Start condition from the master device. The first part of the control byte consists of a 4-bit device code, which is set to 1001 for the MCP3221. The device code is followed by three address bits: A2, A1 and A0. The default address bits are 101. Contact the Microchip factory for additional address bit options. The address bits allow up to eight MCP3221 devices on the same bus and are used to determine which device is accessed.

The eighth bit of the slave address determines if the master device wants to read conversion data or write to the MCP3221. When set to a 1, a read operation is selected. When set to a 0, a write operation is selected. There are no writable registers on the MCP3221, therefore, this bit must be set to a 1 to initiate a conversion.

The MCP3221 is a slave device that is compatible with the 2-wire I<sup>2</sup>C serial interface protocol. A hardware connection diagram is shown in Figure 6-2. Communication is initiated by the microcontroller (master device), which sends a Start bit followed by the address byte.

On completion of the conversion(s) performed by the MCP3221, the microcontroller must send a Stop bit to end the communication.

The last bit in the device address byte is the R/W bit. When this bit is a logic 1, a conversion is executed. Setting this bit to logic 0 also results in an Acknowledge (ACK) from the MCP3221, with the device then releasing the bus. This can be used for device polling. Refer to Section 6.3 “Device Polling” for more information.



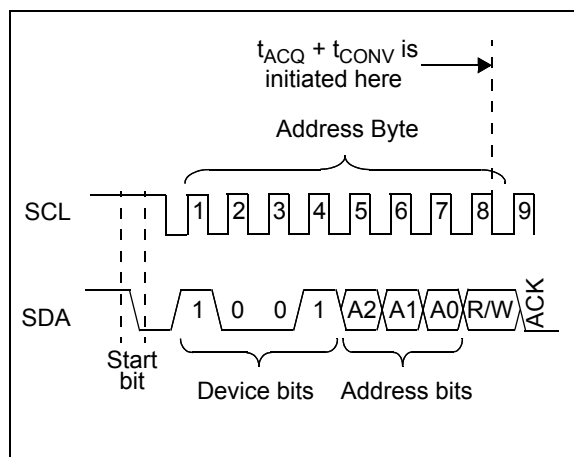
**FIGURE 5-2:** Device Addressing.

## 5.3 Executing a Conversion

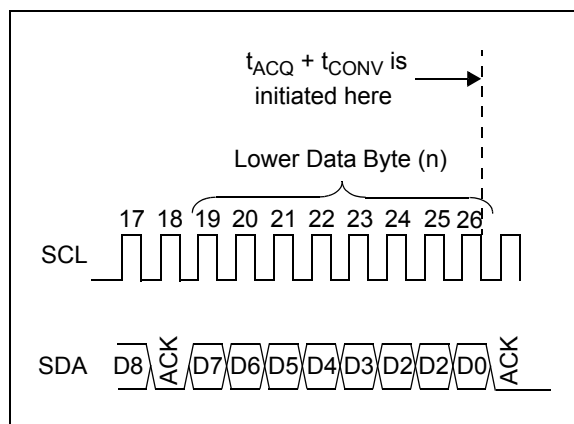
This section describes the details of communicating with the MCP3221 device. Initiating the sample and hold acquisition, reading the conversion data, and executing multiple conversions are discussed.

### 5.3.1 INITIATING THE SAMPLE AND HOLD

The acquisition and conversion of the input signal begins with the falling edge of the R/W bit of the address byte. At this point, the internal clock initiates the sample, hold and conversion cycle, all of which are internal to the ADC.



**FIGURE 5-3:** Initiating the Conversion, Address Byte.



**FIGURE 5-4:** Initiating the Conversion, Continuous Conversions.

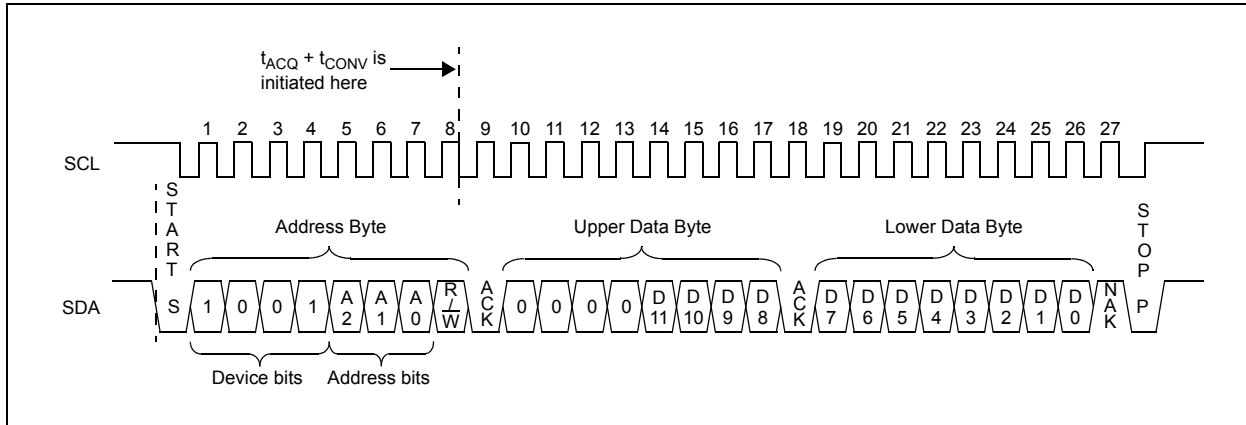
# MCP3221

The input signal is initially sampled with the first falling edge of the clock following the transmission of a logic-high R/W bit. Additionally, with the rising edge of the SCL, the ADC transmits an Acknowledge bit (ACK = 0). The master must release the data bus during this clock pulse to allow the MCP3221 to pull the line low (refer to Figure 5-3).

For consecutive samples, sampling begins on the falling edge of the LSB of the conversion result, which is two bytes long. Refer to Figure 5-6 for the timing diagram.

## 5.3.2 READING THE CONVERSION DATA

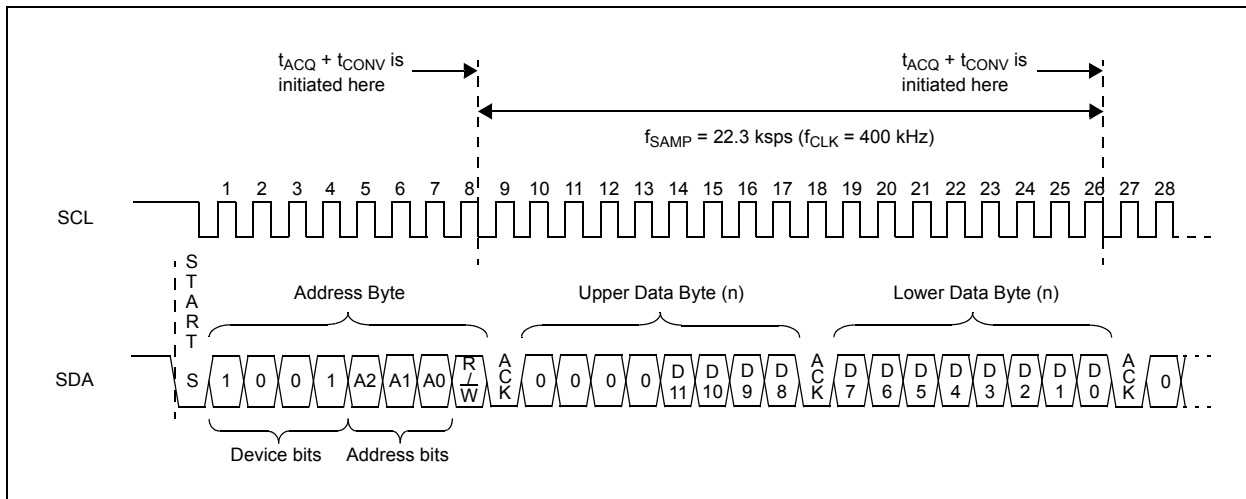
After the MCP3221 acknowledges the address byte, the device transmits four 0 bits followed by the upper four data bits of the conversion. The master device acknowledges this byte with an ACK = Low. With the following eight clock pulses, the MCP3221 transmits the lower eight data bits from the conversion. The master sends an ACK = high, indicating to the MCP3221 that no more data is requested. The master can send a Stop bit to end the transmission.



**FIGURE 5-5:** Executing a Conversion.

## 5.3.3 CONSECUTIVE CONVERSIONS

For consecutive samples, sampling begins on the falling edge of the LSB of the conversion result. See Figure 5-6 for timing.



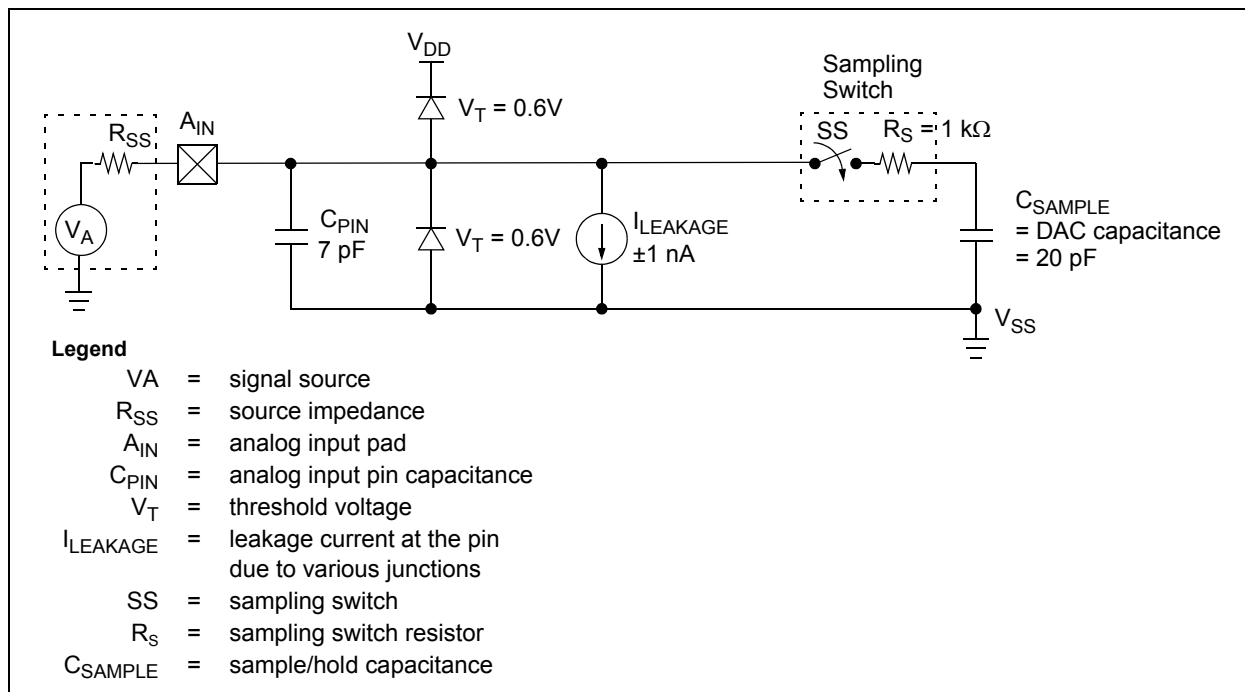
**FIGURE 5-6:** Continuous Conversion.

## 6.0 APPLICATIONS INFORMATION

### 6.1 Driving the Analog Input

The MCP3221 has a single-ended analog input ( $A_{IN}$ ). For proper conversion results, the voltage at the  $A_{IN}$  pin must be kept between  $V_{SS}$  and  $V_{DD}$ . If the converter has no offset error, gain error, INL or DNL errors, and the voltage level of  $A_{IN}$  is equal to or less than  $V_{SS} + 1/2 \text{ LSB}$ , the resultant code is 000h. Additionally, if the voltage at  $A_{IN}$  is equal to or greater than  $V_{DD} - 1.5 \text{ LSB}$ , the output code is FFFh.

The analog input model is shown in Figure 6-1. In this diagram, the source impedance ( $R_{SS}$ ) adds to the internal sampling switch ( $R_S$ ) impedance, directly affecting the time required to charge the capacitor ( $C_{SAMPLE}$ ). Consequently, a larger source impedance increases the offset error, gain error and integral linearity errors of the conversion. Ideally, the impedance of the signal source should be near zero. This is achievable with an operational amplifier such as the MCP6022, which has a closed-loop output impedance of tens of ohms.

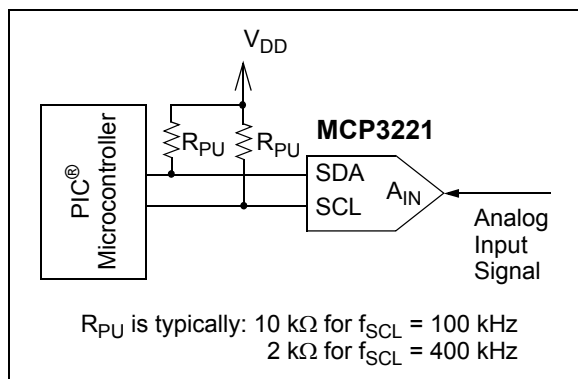


**FIGURE 6-1:** Analog Input Model,  $A_{IN}$ .

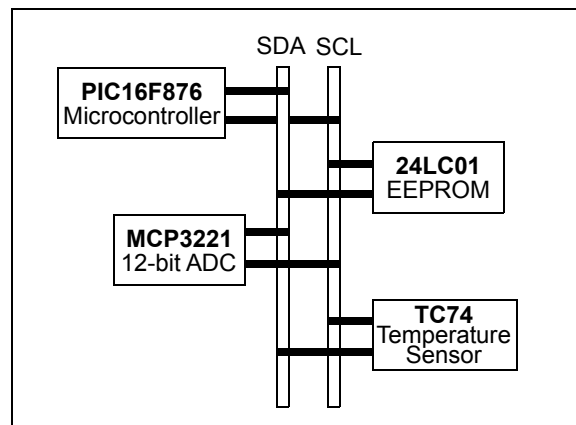
### 6.2 Connecting to the I<sup>2</sup>C Bus

The I<sup>2</sup>C bus is an open collector bus, requiring pull-up resistors connected to the SDA and SCL lines. This configuration is shown in Figure 6-2.

The number of devices connected to the bus is only limited by the maximum bus capacitance of 400 pF. A possible configuration using multiple devices is shown in Figure 6-3.



**FIGURE 6-2:** Pull-up Resistors on I<sup>2</sup>C Bus.



**FIGURE 6-3:** Multiple Devices on I<sup>2</sup>C Bus.

# MCP3221

## 6.3 Device Polling

In some instances, it may be necessary to test for MCP3221 presence on the I<sup>2</sup>C bus without performing a conversion as described in Figure 6-4 where the R/W bit in the address byte is set to a zero. The MCP3221 acknowledges by pulling SDA low during the ACK clock and then release the bus back to the I<sup>2</sup>C master. A Stop or repeated Start bit can be issued from the master and I<sup>2</sup>C communication can continue.

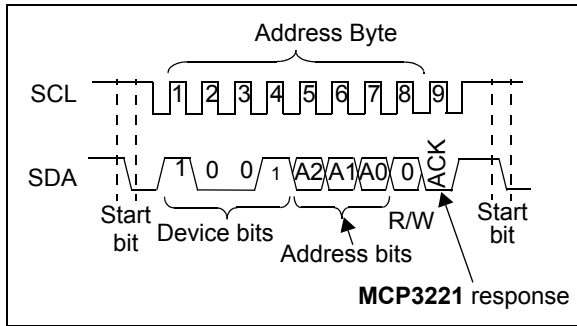


FIGURE 6-4: Device Polling.

## 6.4 Device Power and Layout Considerations

### 6.4.1 POWERING THE MCP3221

V<sub>DD</sub> supplies the power to the device and the reference voltage. A bypass capacitor value of 0.1 μF is recommended. Adding a 10 μF capacitor in parallel is recommended to attenuate higher frequency noise that is present in some systems.

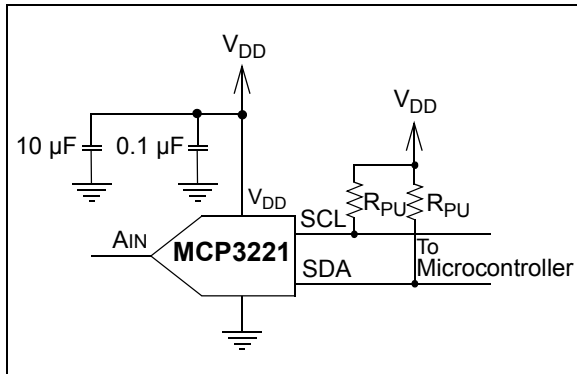


FIGURE 6-5: Powering the MCP3221.

**Note:** When power-down of the MCP3221 is needed during applications (after power-up), it is highly recommended to bring down the V<sub>DD</sub> to V<sub>SS</sub> level. This can guarantee a Full Reset of the device for the next power-up cycle.

### 6.4.2 LAYOUT CONSIDERATIONS

When laying out a printed circuit board for use with analog components, care should be taken to reduce noise wherever possible. A bypass capacitor from V<sub>DD</sub> to ground must be used always with this device and placed as close as possible to the device pin. A bypass capacitor value of 0.1 μF is recommended.

Digital and analog traces should be separated as much as possible on the board, with no traces running underneath the device or the bypass capacitor. Extra precautions should be taken to keep traces with high-frequency signals (such as clock lines) as far as possible from analog traces.

Use of an analog ground plane is recommended in order to keep the ground potential the same for all devices on the board. Providing V<sub>DD</sub> connections to devices in a Star configuration can also reduce noise by eliminating current return paths and associated errors (Figure 6-6). For more information on layout tips when using the MCP3221 or other ADC devices, refer to the Microchip Technology Application Note, “AN688 Layout Tips for 12-Bit A/D Converter Application” (DS00688).

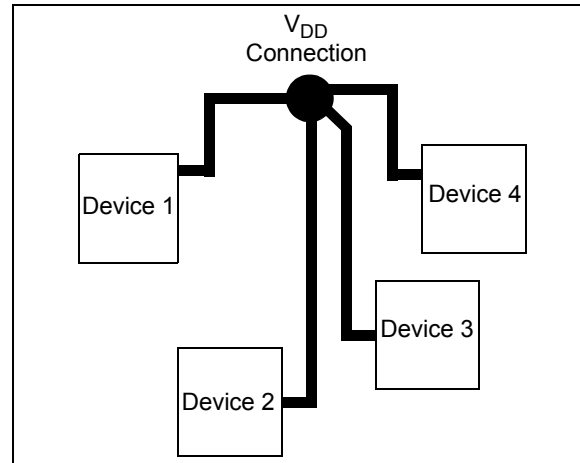
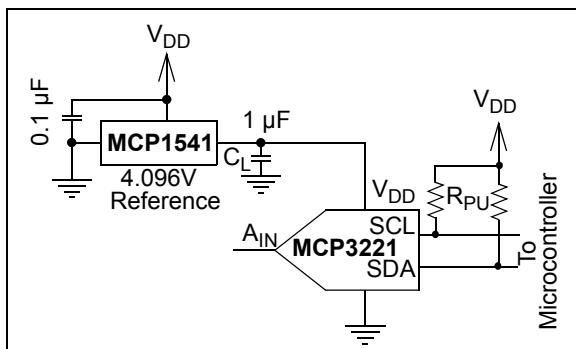


FIGURE 6-6: V<sub>DD</sub> traces arranged in a Star configuration in order to reduce errors caused by current return paths.

## 6.4.3 USING A REFERENCE FOR SUPPLY

The MCP3221 uses  $V_{DD}$  as power and also as a reference. In some applications, it may be necessary to use a stable reference to achieve the required accuracy. Figure 6-7 shows an example using the MCP1541 as a 4.096V, 2% reference.



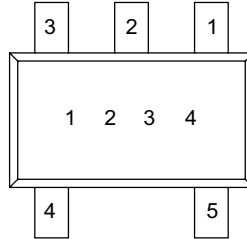
**FIGURE 6-7:** Stable Power and Reference Configuration.

# MCP3221

## 7.0 PACKAGING INFORMATION

### 7.1 Package Marking Information

5-Pin SOT-23



Part Number	Address Option	SOT-23
MCP3221A0T-E/OT	000	GE
MCP3221A1T-E/OT	001	GH
MCP3221A2T-E/OT	010	GB
MCP3221A3T-E/OT	011	GC
MCP3221A4T-E/OT	100	GD
MCP3221A5T-E/OT	101	GA *
MCP3221A6T-E/OT	110	GF
MCP3221A7T-E/OT	111	GG

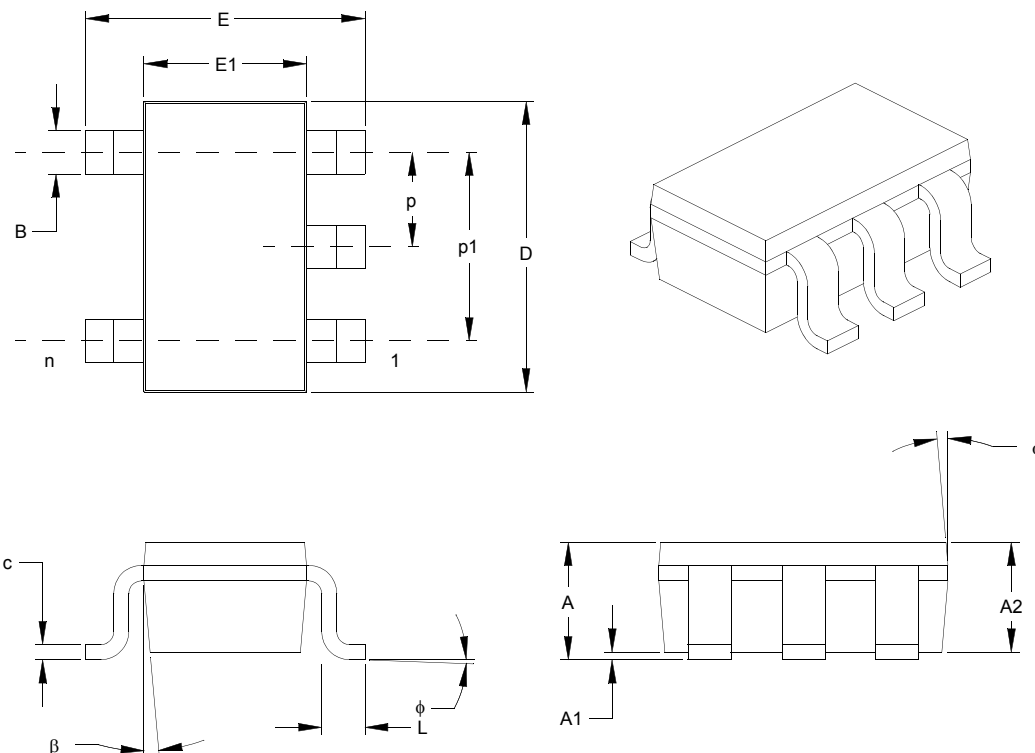
\* Default option. Contact Microchip Factory for other address options.

**Legend:** XX...X Customer-specific information  
Y Year code (last digit of calendar year)  
YY Year code (last 2 digits of calendar year)  
WW Week code (week of January 1 is week '01')  
NNN Alphanumeric traceability code  
Ⓔ3 Pb-free JEDEC designator for Matte Tin (Sn)  
\* This package is Pb-free. The Pb-free JEDEC designator (Ⓔ3) can be found on the outer packaging for this package.

**Note:** In the event the full Microchip part number cannot be marked on one line, it will be carried over to the next line, thus limiting the number of available characters for customer-specific information.

## 5-Lead Plastic Small Outline Transistor (OT) (SOT-23)

**Note:** For the most current package drawings, please see the Microchip Packaging Specification located at <http://www.microchip.com/packaging>



Units		INCHES*			MILLIMETERS		
Dimension Limits		MIN	NOM	MAX	MIN	NOM	MAX
Number of Pins	n		5			5	
Pitch	p		.038			0.95	
Outside lead pitch (basic)	p1		.075			1.90	
Overall Height	A	.035	.046	.057	0.90	1.18	1.45
Molded Package Thickness	A2	.035	.043	.051	0.90	1.10	1.30
Standoff	A1	.000	.003	.006	0.00	0.08	0.15
Overall Width	E	.102	.110	.118	2.60	2.80	3.00
Molded Package Width	E1	.059	.064	.069	1.50	1.63	1.75
Overall Length	D	.110	.116	.122	2.80	2.95	3.10
Foot Length	L	.014	.018	.022	0.35	0.45	0.55
Foot Angle	f	0	5	10	0	5	10
Lead Thickness	c	.004	.006	.008	0.09	0.15	0.20
Lead Width	B	.014	.017	.020	0.35	0.43	0.50
Mold Draft Angle Top	a	0	5	10	0	5	10
Mold Draft Angle Bottom	b	0	5	10	0	5	10

\* Controlling Parameter

**Notes:**

Dimensions D and E1 do not include mold flash or protrusions. Mold flash or protrusions shall not exceed .005" (0.127mm) per side.

EIAJ Equivalent: SC-74A

Drawing No. C04-091

Revised 09-12-05



# MCP3221

---

NOTES:

## APPENDIX A: REVISION HISTORY

### Revision E (January 2017)

- Added a note to [Section 6.4.1 “Powering the MCP3221”](#).
- Fixed [Section 7.1 “Package Marking Information”](#) format to reflect the correct package marking as “1 2 3 4” instead of “1 10 10 10”.
- Updated Temperature Specifications table to remove information on Industrial Temperature Range

### Revision D (January 2013)

- Added a note to each package outline drawing.

### Revision C (July 2006)

- Updated [Section 5.2 “Device Addressing”](#): changed 4-bit device code to “1001”. Changed three address bits to “101”.

### Revision B (May 2003)

- Numerous changes throughout document.

### Revision A (November 2002)

- Original Release of this Document.