



Chipsmall Limited consists of a professional team with an average of over 10 year of expertise in the distribution of electronic components. Based in Hongkong, we have already established firm and mutual-benefit business relationships with customers from,Europe,America and south Asia,supplying obsolete and hard-to-find components to meet their specific needs.

With the principle of “Quality Parts,Customers Priority,Honest Operation,and Considerate Service”,our business mainly focus on the distribution of electronic components. Line cards we deal with include Microchip,ALPS,ROHM,Xilinx,Pulse,ON,Everlight and Freescale. Main products comprise IC,Modules,Potentiometer,IC Socket,Relay,Connector.Our parts cover such applications as commercial,industrial, and automotives areas.

We are looking forward to setting up business relationship with you and hope to provide you with the best service and solution. Let us make a better world for our industry!



Contact us

Tel: +86-755-8981 8866 Fax: +86-755-8427 6832

Email & Skype: info@chipsmall.com Web: www.chipsmall.com

Address: A1208, Overseas Decoration Building, #122 Zhenhua RD., Futian, Shenzhen, China



13-Bit Differential Input, Low Power A/D Converter with SPI Serial Interface

Features

- Full Differential Inputs
- ± 1 LSB max DNL
- ± 1 LSB max INL (MCP3301-B)
- ± 2 LSB max INL (MCP3301-C)
- Single supply operation: 4.5V to 5.5V
- 100 ksp/s sampling rate with 5V supply voltage
- 50 nA typical standby current, 1 μ A max
- 450 μ A max active current at 5V
- Industrial temp range: -40°C to $+85^{\circ}\text{C}$
- 8-pin MSOP, PDIP, and SOIC packages
- Mixed Signal PICtail™ Demo Board (P/N: MXSIGDM) compatible

Applications

- Remote Sensors
- Battery-operated Systems
- Transducer Interface

Functional Block Diagram

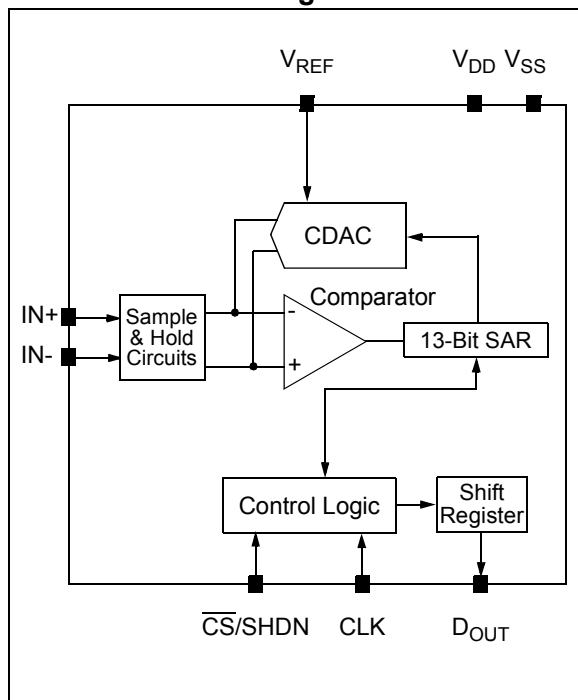

General Description

The MCP3301 13-bit analog-to-digital (A/D) converter features full differential inputs and low power consumption in a small package that is ideal for battery-powered systems and remote data acquisition applications.

Incorporating a successive approximation architecture with on-board sample and hold circuitry, the 13-bit A/D converter is specified to have ± 1 LSB Differential Non-linearity (DNL) and ± 1 LSB Integral Nonlinearity (INL) for B-grade devices and ± 2 LSB for C-grade devices. The industry-standard SPI serial interface enables 13-bit A/D converter capability to be added to any PIC® microcontroller.

The MCP3301 features a low current design that permits operation with typical standby and active currents of only 50 nA and 300 μ A, respectively. The device is capable of conversion rates of up to 100 ksp/s with tested specifications over a 4.5V to 5.5V supply range. The reference voltage can be varied from 400 mV to 5V, yielding input-referred resolution between 98 μ V and 1.22 mV.

The MCP3301 is available in 8-pin PDIP, 150 mil SOIC, and MSOP packages. The full differential inputs of this device enable a wide variety of signals to be used in applications such as remote data acquisition, portable instrumentation, and battery-operated applications.

Package Types

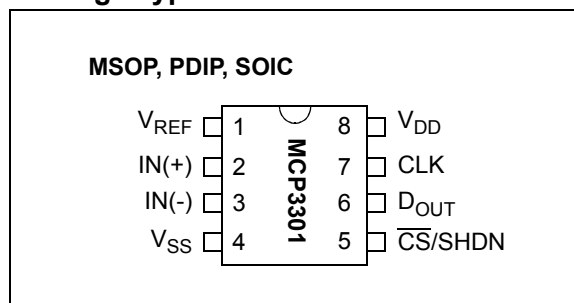

MCP3301

1.0 ELECTRICAL CHARACTERISTICS

Maximum Ratings*

V_{DD}	7.0V
All inputs and outputs w.r.t. V_{SS}	-0.3V to V_{DD} +0.3V
Storage temperature	-65°C to +150°C
Ambient temperature with power applied	-65°C to +125°C
Maximum Junction Temperature	150°C
ESD protection on all pins (HBM)	> 4 kV

***Notice:** Stresses above those listed under “Maximum ratings” may cause permanent damage to the device. This is a stress rating only and functional operation of the device at those or any other conditions above those indicated in the operational listings of this specification is not implied. Exposure to maximum rating conditions for extended periods may affect device reliability.

ELECTRICAL CHARACTERISTICS

Electrical Characteristics: Unless otherwise noted, all parameters apply at $V_{DD} = 5V$, $V_{SS} = 0V$, and $V_{REF} = 5V$. Full differential input configuration (Figure 1-5) with fixed common mode voltage of 2.5V. All parameters apply over temperature with $T_{AMB} = -40^{\circ}C$ to $+85^{\circ}C$ (Note 7). Conversion speed (F_{SAMPLE}) is 100 kps with $F_{CLK} = 17 * F_{SAMPLE}$

Parameter	Symbol	Min	Typ	Max	Units	Conditions
Conversion Rate						
Maximum Sampling Frequency	F_{SAMPLE}	—	—	100	kps	See F_{CLK} specifications (Note 8)
Conversion Time	t_{CONV}		13		CLK periods	
Acquisition Time	t_{ACQ}		1.5		CLK periods	
DC Accuracy						
Resolution		12 data bits + sign			bits	
Integral Nonlinearity	INL	—	±0.5 ±1	±1 ±2	LSB	MCP3301-B MCP3301-C
Differential Nonlinearity	DNL	—	±0.5	±1	LSB	Monotonic with no missing codes over temperature
Positive Gain Error		-3	-0.75	+2	LSB	
Negative Gain Error		-3	-0.5	+2	LSB	
Offset Error		-3	+3	+6	LSB	
Dynamic Performance						
Total Harmonic Distortion	THD	—	-91	—	dB	Note 3
Signal to Noise and Distortion	SINAD	—	78	—	dB	Note 3
Spurious Free Dynamic Range	SFDR	—	92	—	dB	Note 3
Common-Mode Rejection	CMRR	—	79	—	dB	Note 6
Power Supply Rejection	PSR	—	74	—	dB	Note 4

- Note**
- 1: This specification is established by characterization and not 100% tested.
 - 2: See characterization graphs that relate converter performance to V_{REF} level.
 - 3: $V_{IN} = 0.1V$ to $4.9V @ 1 kHz$.
 - 4: $V_{DD} = 5V$ DC $\pm 500 mV_{P-P} @ 1 kHz$, see test circuit Figure 1-4.
 - 5: Maximum clock frequency specification must be met.
 - 6: $V_{REF} = 400 mV$, $V_{IN} = 0.1V$ to $4.9V @ 1 kHz$
 - 7: MSOP devices are only specified at $25^{\circ}C$ and $+85^{\circ}C$.
 - 8: For slow sample rates, see Section 5.2.1 “Maintaining Minimum Clock Speed” for limitations on clock frequency.
 - 9: 4.5V - 5.5V is the supply voltage range for specified performance

ELECTRICAL CHARACTERISTICS (CONTINUED)

Electrical Characteristics: Unless otherwise noted, all parameters apply at $V_{DD} = 5V$, $V_{SS} = 0V$, and $V_{REF} = 5V$. Full differential input configuration (Figure 1-5) with fixed common mode voltage of 2.5V. All parameters apply over temperature with $T_{AMB} = -40^{\circ}C$ to $+85^{\circ}C$ (Note 7). Conversion speed (F_{SAMPLE}) is 100 ksp/s with $F_{CLK} = 17 \cdot F_{SAMPLE}$

Parameter	Symbol	Min	Typ	Max	Units	Conditions
Reference Input						
Voltage Range		0.4	—	V_{DD}	V	Note 2
Current Drain		— —	100 0.001	150 3	μA μA	$\overline{CS} = V_{DD} = 5V$
Analog Inputs						
Full-Scale Input Span	IN(+)-IN(-)	$-V_{REF}$	—	V_{REF}	V	
Absolute Input Voltage	IN(+)	-0.3	—	$V_{DD} + 0.3$	V	
	IN(-)	-0.3	—	$V_{DD} + 0.3$	V	
Leakage Current		—	0.001	± 1	μA	
Switch Resistance	R_S	—	1	—	k Ω	See Figure 5-3
Sample Capacitor	C_{SAMPLE}	—	25	—	pF	See Figure 5-3
Digital Input/Output						
Data Coding Format		Binary Two's Complement				
High Level Input Voltage	V_{IH}	$0.7 V_{DD}$	—	—	V	
Low Level Input Voltage	V_{IL}	—	—	$0.3 V_{DD}$	V	
High Level Output Voltage	V_{OH}	4.1	—	—	V	$I_{OH} = -1 \text{ mA}$, $V_{DD} = 4.5V$
Low Level Output Voltage	V_{OL}	—	—	0.4	V	$I_{OL} = 1 \text{ mA}$, $V_{DD} = 4.5V$
Input Leakage Current	I_{LI}	-10	—	10	μA	$V_{IN} = V_{SS}$ or V_{DD}
Output Leakage Current	I_{LO}	-10	—	10	μA	$V_{OUT} = V_{SS}$ or V_{DD}
Pin Capacitance	C_{IN}, C_{OUT}	—	—	10	pF	$T_{AMB} = 25^{\circ}C$, $f = 1 \text{ MHz}$, Note 1
Timing Specifications						
Clock Frequency (Note 8)	F_{CLK}	0.085	—	1.7	MHz	$V_{DD} = 5V$, $F_{SAMPLE} = 100 \text{ ksp/s}$
Clock High Time	t_{HI}	275	—	—	ns	Note 5
Clock Low Time	t_{LO}	275	—	—	ns	Note 5
\overline{CS} Fall To First Rising CLK Edge	t_{SUCS}	100	—	—	ns	
CLK Fall To Output Data Valid	t_{DO}	—	—	125 200	ns ns	$V_{DD} = 5V$, see Figure 1-2 $V_{DD} = 2.7V$, see Figure 1-2
CLK Fall To Output Enable	t_{EN}	—	—	125 200	ns ns	$V_{DD} = 5V$, see Figure 1-2 $V_{DD} = 2.7V$, see Figure 1-2
\overline{CS} Rise To Output Disable	t_{DIS}	—	—	100	ns	See test circuits, Figure 1-2; Note 1
\overline{CS} Disable Time	t_{CSH}	580	—	—	ns	
D_{OUT} Rise Time	t_R	—	—	100	ns	See test circuits, Figure 1-2; Note 1
D_{OUT} Fall Time	t_F	—	—	100	ns	See test circuits, Figure 1-2; Note 1

- Note 1:** This specification is established by characterization and not 100% tested.
Note 2: See characterization graphs that relate converter performance to V_{REF} level.
Note 3: $V_{IN} = 0.1V$ to $4.9V$ @ 1 kHz .
Note 4: $V_{DD} = 5V$ DC $\pm 500 \text{ mV}_{P-P}$ @ 1 kHz , see test circuit Figure 1-4.
Note 5: Maximum clock frequency specification must be met.
Note 6: $V_{REF} = 400 \text{ mV}$, $V_{IN} = 0.1V$ to $4.9V$ @ 1 kHz
Note 7: MSOP devices are only specified at $25^{\circ}C$ and $+85^{\circ}C$.
Note 8: For slow sample rates, see Section 5.2.1 "Maintaining Minimum Clock Speed" for limitations on clock frequency.
Note 9: $4.5V - 5.5V$ is the supply voltage range for specified performance

MCP3301

ELECTRICAL CHARACTERISTICS (CONTINUED)

Electrical Characteristics: Unless otherwise noted, all parameters apply at $V_{DD} = 5V$, $V_{SS} = 0V$, and $V_{REF} = 5V$. Full differential input configuration (Figure 1-5) with fixed common mode voltage of 2.5V. All parameters apply over temperature with $T_{AMB} = -40^{\circ}C$ to $+85^{\circ}C$ (Note 7). Conversion speed (F_{SAMPLE}) is 100 ksp/s with $F_{CLK} = 17 * F_{SAMPLE}$

Parameter	Symbol	Min	Typ	Max	Units	Conditions
Power Requirements						
Operating Voltage	V_{DD}	4.5	—	5.5	V	Note 9
Operating Current	I_{DD}	—	300	450	μA	$V_{DD}, V_{REF} = 5V, D_{OUT}$ unloaded $V_{DD}, V_{REF} = 2.7V, D_{OUT}$ unloaded
Standby Current	I_{DDS}	—	0.05	1	μA	$\overline{CS} = V_{DD} = 5.0V$
Temperature Ranges						
Specified Temperature Range	T_A	-40	—	+85	$^{\circ}C$	
Operating Temperature Range	T_A	-40	—	+85	$^{\circ}C$	
Storage Temperature Range	T_A	-65	—	+150	$^{\circ}C$	
Thermal Package Resistance						
Thermal Resistance, 8L-MSOP	θ_{JA}	—	206	—	$^{\circ}C/W$	
Thermal Resistance, 8L-PDIP	θ_{JA}	—	85	—	$^{\circ}C/W$	
Thermal Resistance, 8L-SOIC	θ_{JA}	—	163	—	$^{\circ}C/W$	

- Note**
- 1: This specification is established by characterization and not 100% tested.
 - 2: See characterization graphs that relate converter performance to V_{REF} level.
 - 3: $V_{IN} = 0.1V$ to $4.9V @ 1 kHz$.
 - 4: $V_{DD} = 5V DC \pm 500 mV_{P-P} @ 1 kHz$, see test circuit Figure 1-4.
 - 5: Maximum clock frequency specification must be met.
 - 6: $V_{REF} = 400 mV, V_{IN} = 0.1V$ to $4.9V @ 1 kHz$
 - 7: MSOP devices are only specified at $25^{\circ}C$ and $+85^{\circ}C$.
 - 8: For slow sample rates, see Section 5.2.1 "Maintaining Minimum Clock Speed" for limitations on clock frequency.
 - 9: 4.5V - 5.5V is the supply voltage range for specified performance

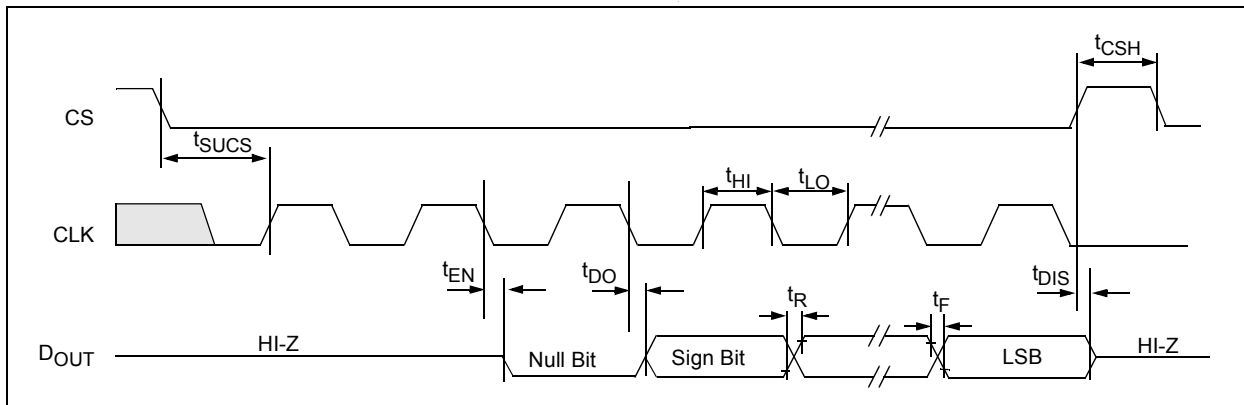

FIGURE 1-1: Timing Parameters.

1.1 Test Circuits

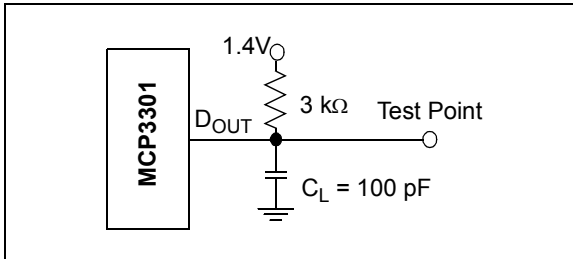

FIGURE 1-2: Load Circuit for t_R , t_F , t_{DO} .

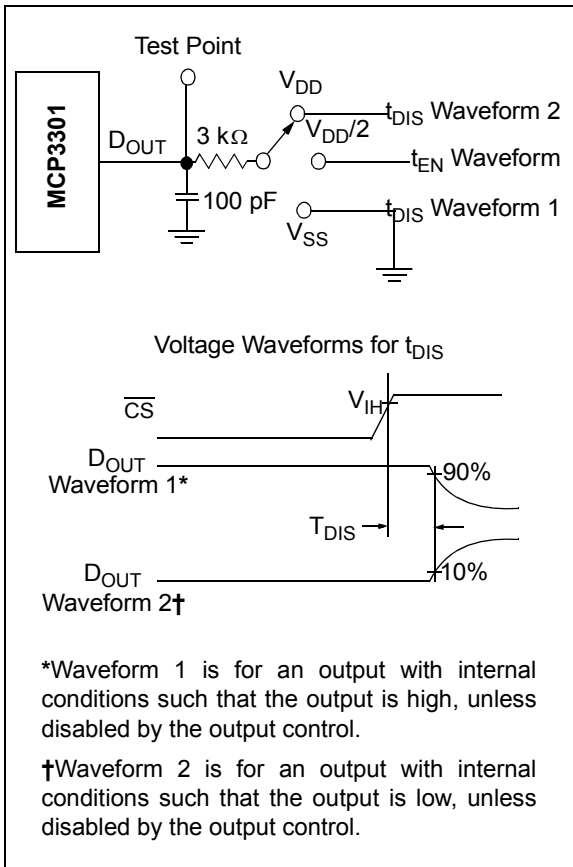

FIGURE 1-3: Load Circuit for T_{DIS} and T_{EN} .

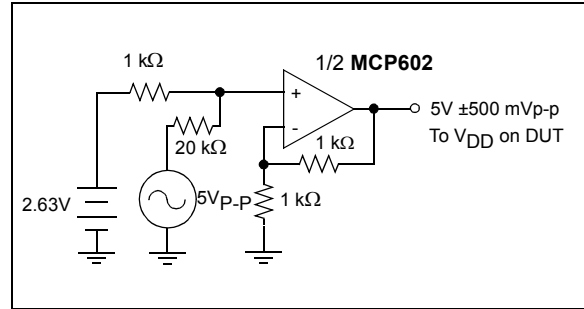

FIGURE 1-4: Power Supply Sensitivity Test Circuit (PSRR).

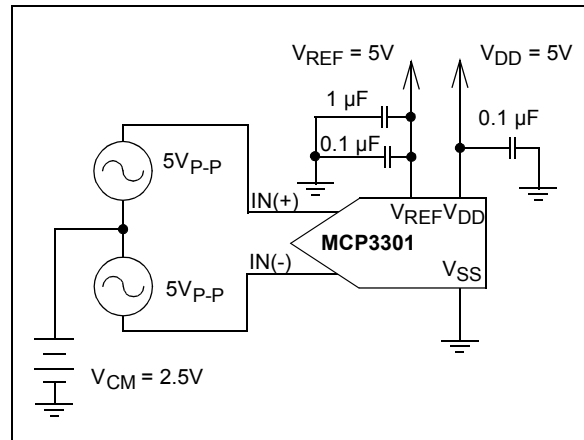

FIGURE 1-5: Full Differential Test Configuration Example.

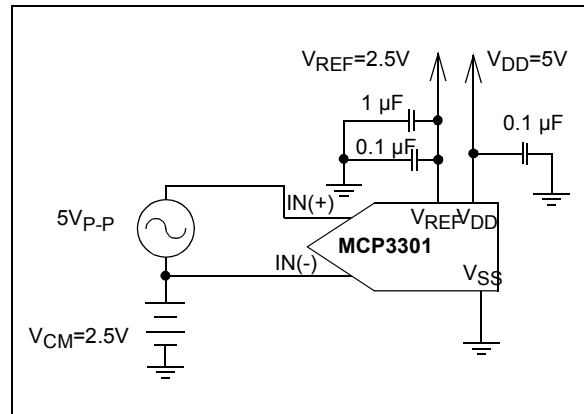

FIGURE 1-6: Pseudo Differential Test Configuration Example.

MCP3301

2.0 TYPICAL PERFORMANCE CURVES

Note: The graphs and tables provided following this note are a statistical summary based on a limited number of samples and are provided for informational purposes only. The performance characteristics listed herein are not tested or guaranteed. In some graphs or tables, the data presented may be outside the specified operating range (e.g., outside specified power supply range) and therefore outside the warranted range.

Note: Unless otherwise indicated, $V_{DD} = V_{REF} = 5V$, Full differential input configuration, $V_{SS} = 0V$, $F_{SAMPLE} = 100$ kpsps, $F_{CLK} = 17 \cdot F_{SAMPLE}$, $T_A = 25^\circ C$.

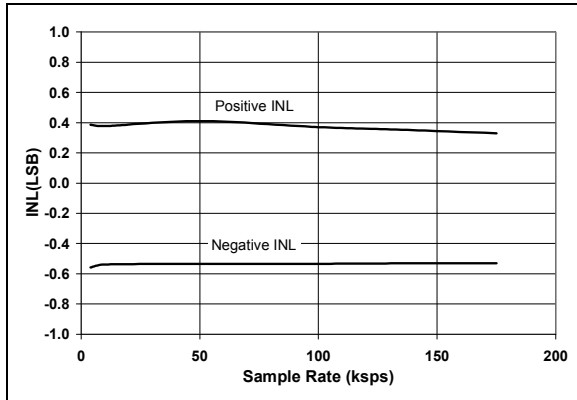

FIGURE 2-1: Integral Nonlinearity (INL) vs. Sample Rate.

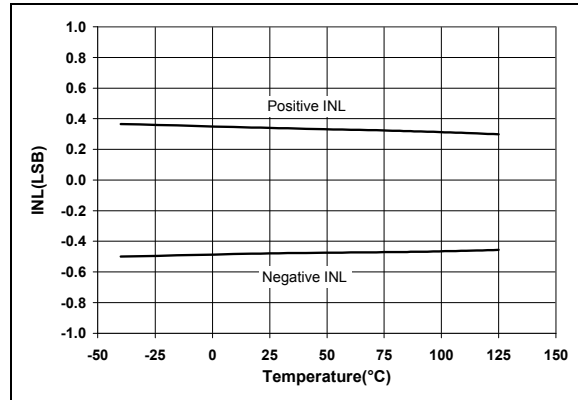

FIGURE 2-4: Integral Nonlinearity (INL) vs. Temperature.

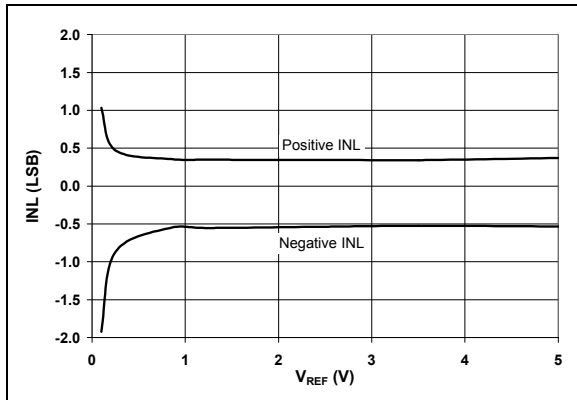

FIGURE 2-2: Integral Nonlinearity (INL) vs. V_{REF} .

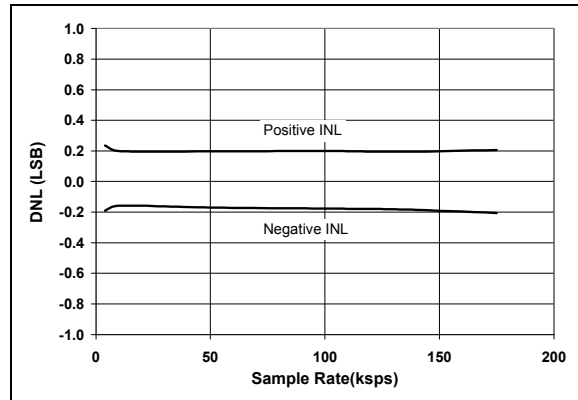

FIGURE 2-5: Differential Nonlinearity (DNL) vs. Sample Rate.

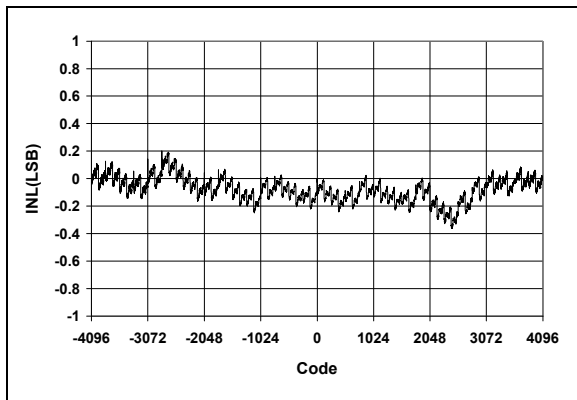

FIGURE 2-3: Integral Nonlinearity (INL) vs. Code (Representative Part).

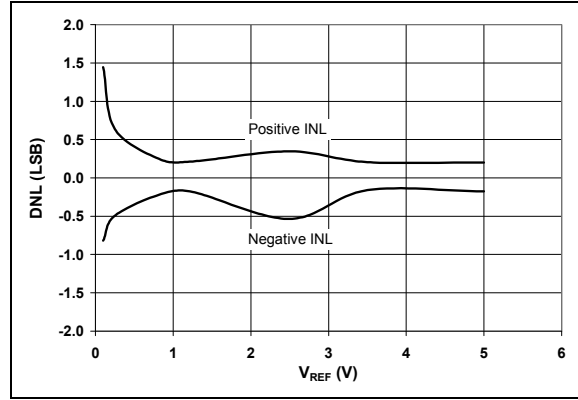

FIGURE 2-6: Differential Nonlinearity (DNL) vs. V_{REF} .

Note: Unless otherwise indicated, $V_{DD} = V_{REF} = 5V$, Full differential input configuration, $V_{SS} = 0V$, $F_{SAMPLE} = 100$ kpsps, $F_{CLK} = 17 \cdot F_{SAMPLE}$, $T_A = 25^\circ C$.

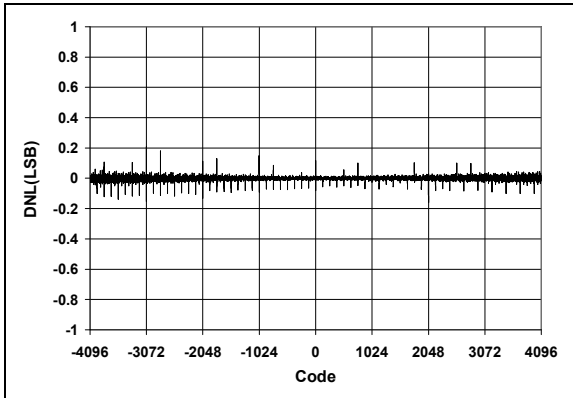

FIGURE 2-7: Differential Nonlinearity (DNL) vs. Code (Representative Part).

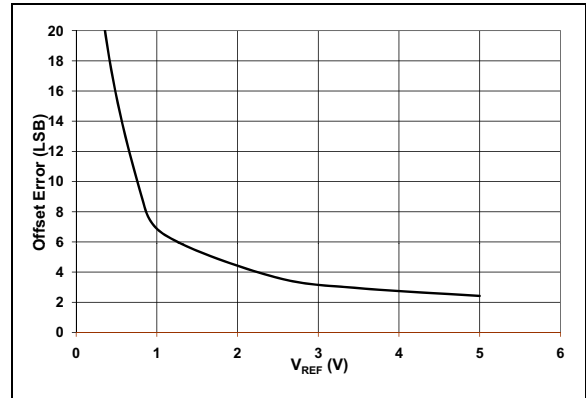

FIGURE 2-10: Offset Error vs. V_{REF} .

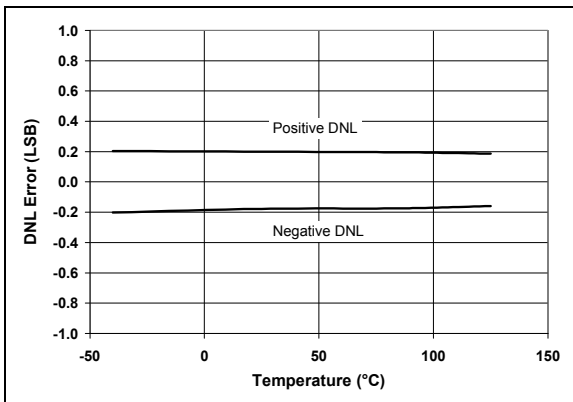

FIGURE 2-8: Differential Nonlinearity (DNL) vs. Temperature.

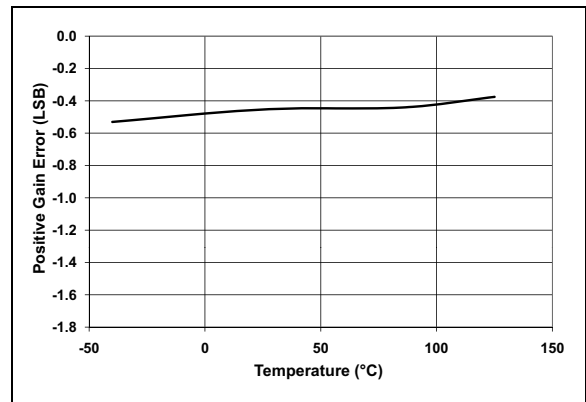

FIGURE 2-11: Positive Gain Error vs. Temperature.

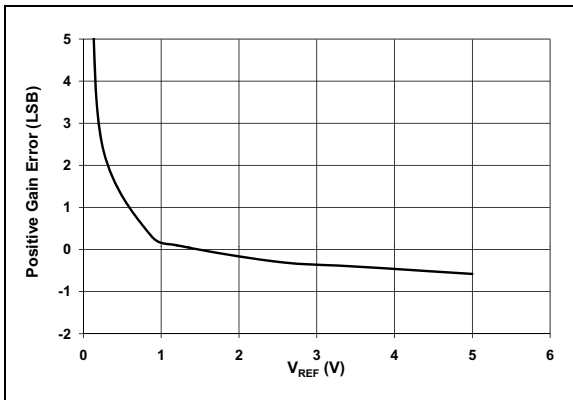

FIGURE 2-9: Positive Gain Error vs. V_{REF} .

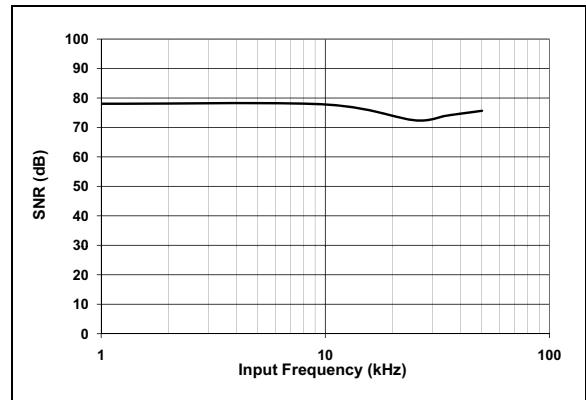

FIGURE 2-12: Signal to Noise Ratio (SNR) vs. Input Frequency.

MCP3301

Note: Unless otherwise indicated, $V_{DD} = V_{REF} = 5V$, Full differential input configuration, $V_{SS} = 0V$, $F_{SAMPLE} = 100$ kpsps, $F_{CLK} = 17 \cdot F_{SAMPLE}$, $T_A = 25^\circ C$.

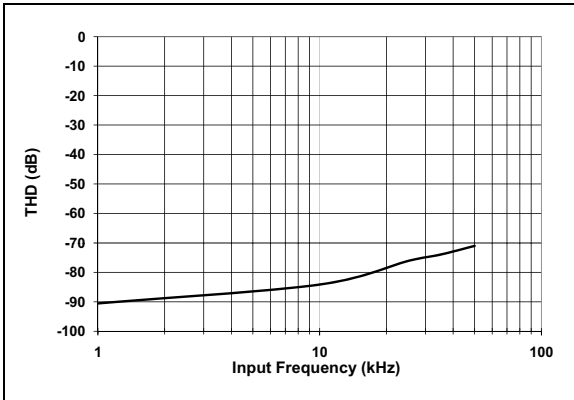

FIGURE 2-13: Total Harmonic Distortion (THD) vs. Input Frequency.

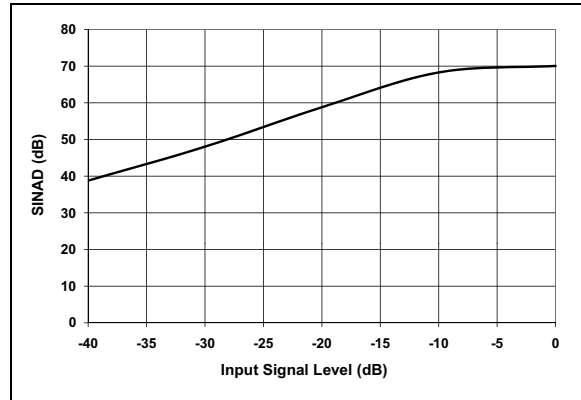

FIGURE 2-16: Signal to Noise and Distortion (SINAD) vs. Input Signal Level.

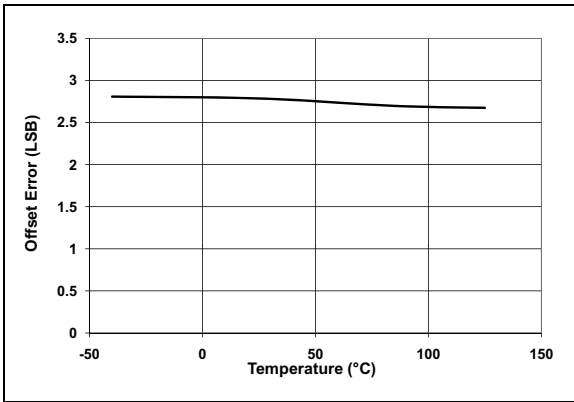

FIGURE 2-14: Offset Error vs. Temperature.

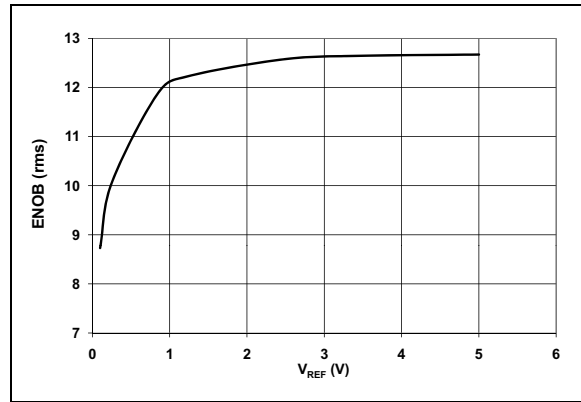

FIGURE 2-17: Effective Number of Bits (ENOB) vs. V_{REF} .

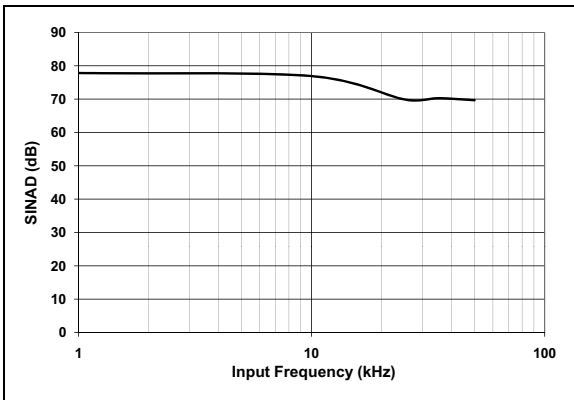

FIGURE 2-15: Signal to Noise and Distortion (SINAD) vs. Input Frequency.

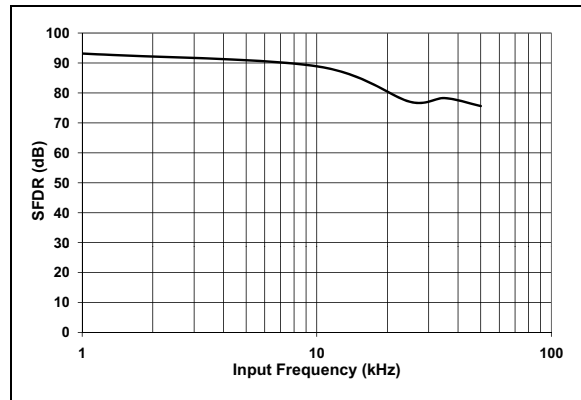

FIGURE 2-18: Spurious Free Dynamic Range (SFDR) vs. Input Frequency.

Note: Unless otherwise indicated, $V_{DD} = V_{REF} = 5V$, Full differential input configuration, $V_{SS} = 0V$, $F_{SAMPLE} = 100$ kps, $F_{CLK} = 17 \cdot F_{SAMPLE}$, $T_A = 25^\circ C$.

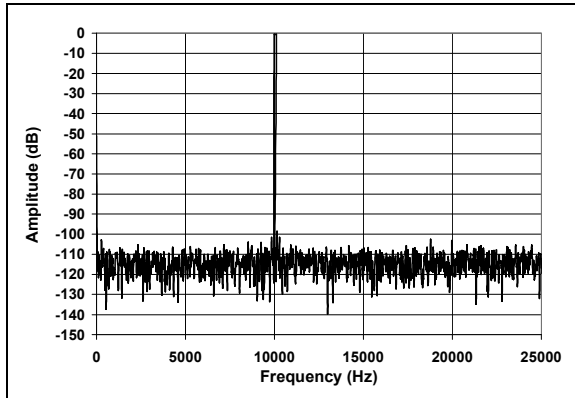

FIGURE 2-19: Frequency Spectrum of 10 kHz Input (Representative Part).

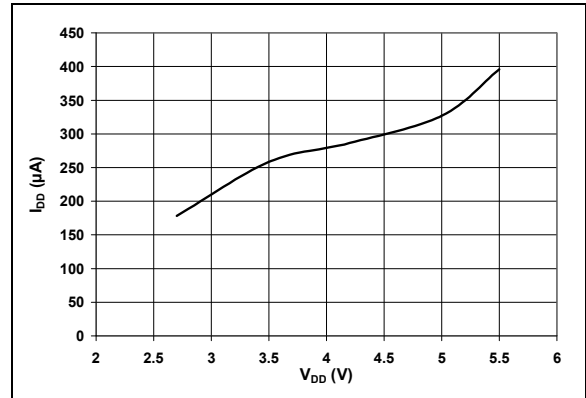

FIGURE 2-22: I_{DD} vs. V_{DD} .

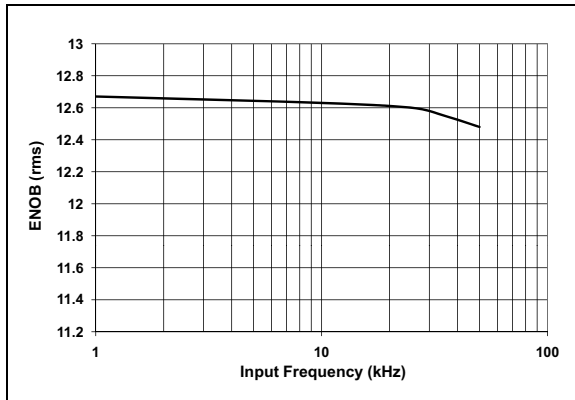

FIGURE 2-20: Effective Number of Bits (ENOB) vs. Input Frequency.

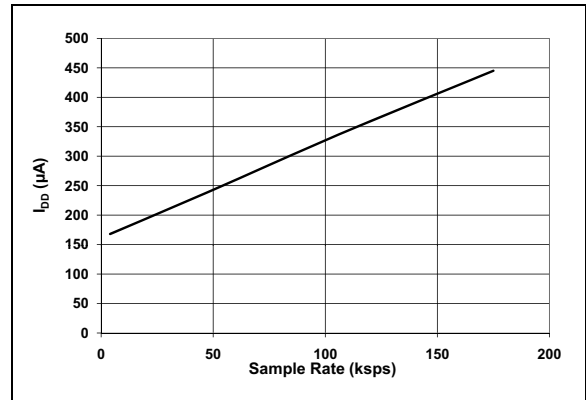

FIGURE 2-23: I_{DD} vs. Sample Rate.

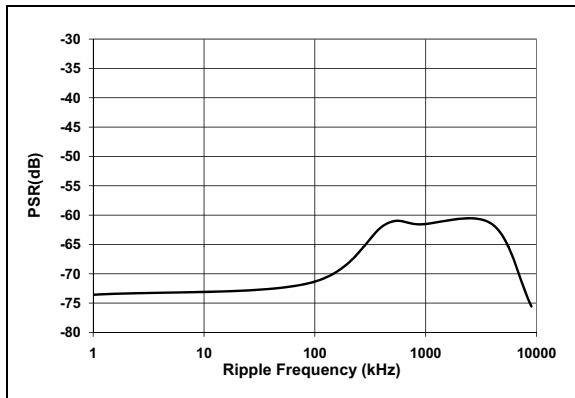

FIGURE 2-21: Power Supply Rejection (PSR) vs. Ripple Frequency. A $0.1 \mu F$ bypass capacitor is connected to the V_{DD} pin.

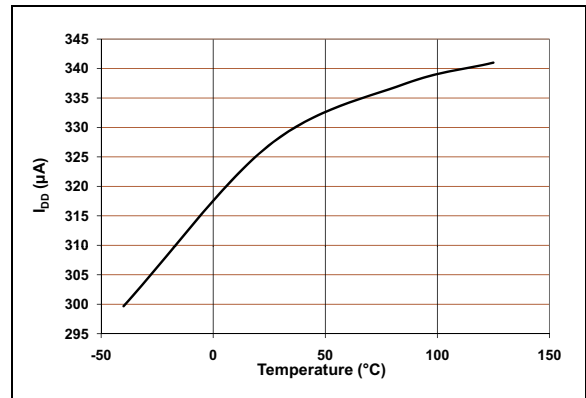

FIGURE 2-24: I_{DD} vs. Temperature.

MCP3301

Note: Unless otherwise indicated, $V_{DD} = V_{REF} = 5V$, Full differential input configuration, $V_{SS} = 0V$, $F_{SAMPLE} = 100$ ksp/s, $F_{CLK} = 17 \cdot F_{SAMPLE}$, $T_A = 25^\circ C$.

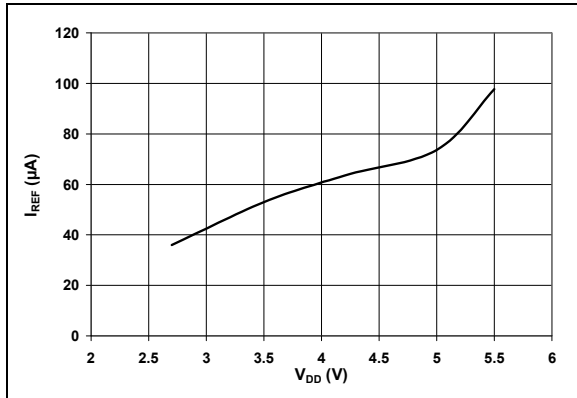

FIGURE 2-25: I_{REF} vs. V_{DD} .

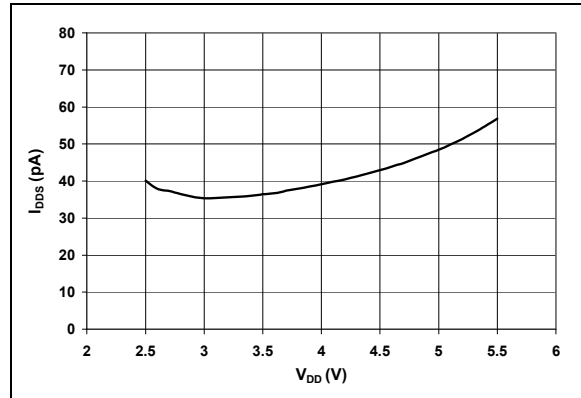

FIGURE 2-28: I_{DDS} vs. V_{DD} .

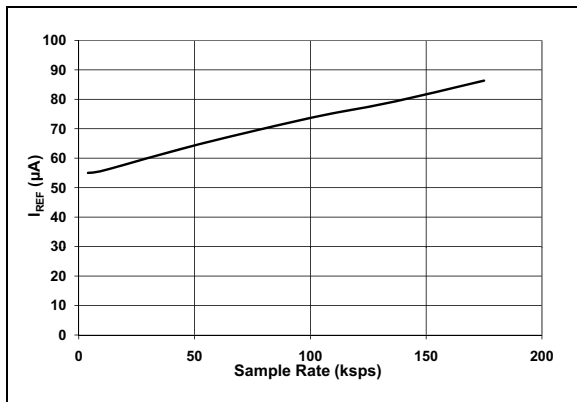

FIGURE 2-26: I_{REF} vs. Sample Rate.

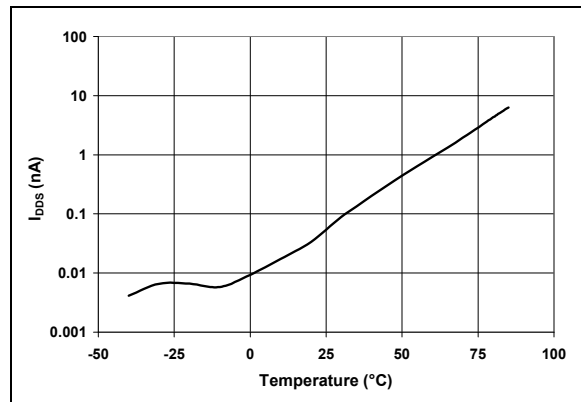

FIGURE 2-29: I_{DDS} vs. Temperature.

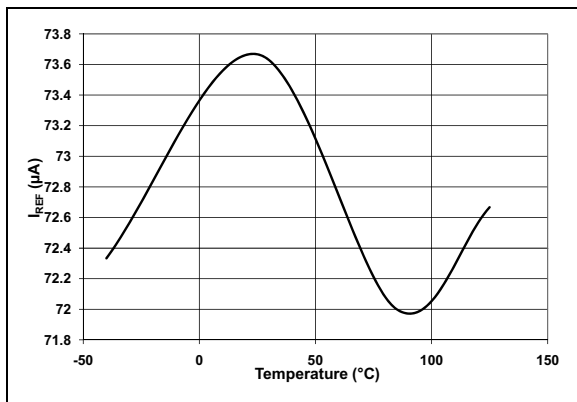

FIGURE 2-27: I_{REF} vs. Temperature.

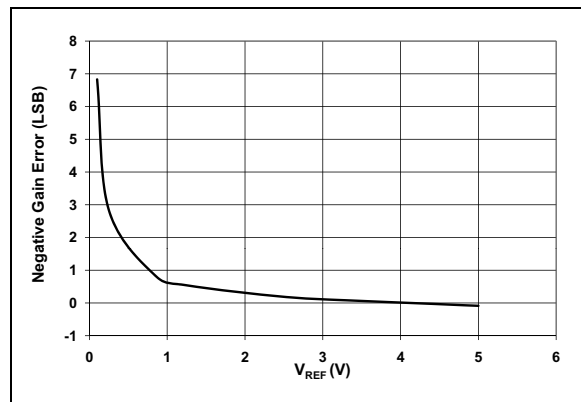

FIGURE 2-30: Negative Gain Error vs. Reference Voltage.

Note: Unless otherwise indicated, $V_{DD} = V_{REF} = 5V$, Full differential input configuration, $V_{SS} = 0V$, $F_{SAMPLE} = 100$ ksp/s, $F_{CLK} = 17 * F_{SAMPLE}$, $T_A = 25^{\circ}C$.

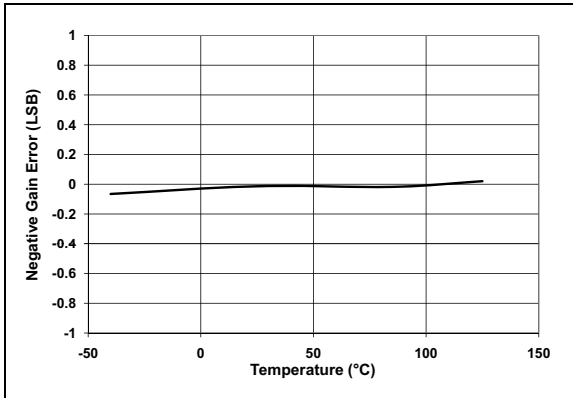

FIGURE 2-31: Negative Gain Error vs. Temperature.

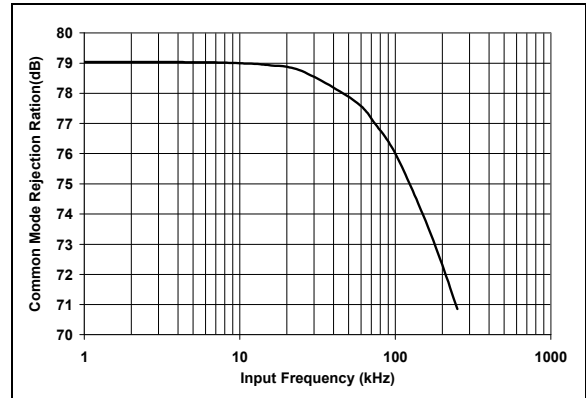

FIGURE 2-32: Common Mode Rejection vs. Frequency.

MCP3301

3.0 PIN DESCRIPTIONS

The descriptions of the pins are listed in [Table 3-1](#).

TABLE 3-1: PIN FUNCTION TABLE

MSOP, PDIP, SOIC	Name	Function
1	V _{REF}	Reference Voltage Input
2	IN(+)	Positive Analog Input
3	IN(-)	Negative Analog Input
4	V _{SS}	Ground
5	$\overline{\text{CS}}/\text{SHDN}$	Chip Select / Shutdown Input
6	D _{OUT}	Serial Data Out
7	CLK	Serial Clock
8	V _{DD}	+4.5V to 5.5V Power Supply

3.1 Voltage Reference (V_{REF})

This input pin provides the reference voltage for the device, which determines the maximum range of the analog input signal and the LSB size.

The LSB size is determined by the equation shown below. As the reference input is reduced, the LSB size is reduced accordingly.

EQUATION

$$\text{LSB Size} = \frac{2 \times V_{\text{REF}}}{8192}$$

When using an external voltage reference device, the system designer should always refer to the manufacturer's recommendations for circuit layout. Any instability in the operation of the reference device will have a direct effect on the accuracy of the ADC conversion results.

3.2 Positive Analog Input (IN+)

This pin has an absolute voltage range of V_{SS}-0.3V to V_{DD}+0.3V. The full scale input range is defined as the absolute value of (IN+) - (IN-).

3.3 Negative Analog Input (IN-)

This pin has an absolute voltage range of V_{SS}-0.3V to V_{DD}+0.3V. The full scale input range is defined as the absolute value of (IN+) - (IN-).

3.4 Ground Connection (V_{SS})

If an analog ground plane is available, it is recommended that this device be tied to the analog ground plane in the circuit. See [Section 5.6 "Layout Considerations"](#), for more information regarding circuit layout.

3.5 Chip Select/Shutdown ($\overline{\text{CS}}/\text{SHDN}$)

The $\overline{\text{CS}}/\text{SHDN}$ pin is used to initiate communication with the device when pulled low. This pin will end a conversion and put the device in low power standby when pulled high. The $\overline{\text{CS}}/\text{SHDN}$ pin must be pulled high between conversions and cannot be tied low for multiple conversions. See [Figure 6-2](#) for serial communication protocol.

3.6 Serial Data Output (D_{OUT})

The SPI serial data output pin is used to shift out the results of the A/D conversion. Data will always change on the falling edge of each clock as the conversion takes place. See [Figure 6-2](#) for serial communication protocol.

3.7 Serial Clock (CLK)

The SPI clock pin is used to initiate a conversion, as well as to clock out each bit of the conversion as it takes place. See [Section 5.2 "Driving the Analog Input"](#) for constraints on clock speed, and [Figure 6-2](#) for serial communication protocol.

3.8 Power Supply (V_{DD})

The device can operate from 2.7V to 5.5V, but the performance is applicable from a 4.5V to 5.5V supply range. To ensure accuracy, a 0.1 μF ceramic bypass capacitor should be placed as close as possible to the pin. See [Section 5.6 "Layout Considerations"](#) for more information regarding circuit layout.

4.0 DEFINITION OF TERMS

Bipolar Operation - This applies to either a differential or single-ended input configuration, where both positive and negative codes are output from the A/D converter. Full bipolar range includes all 8192 codes. For bipolar operation on a single-ended input signal, the A/D converter must be configured to operate in pseudo differential mode.

Unipolar Operation - This applies to either a single-ended or differential input signal where only one side of the device transfer is being used. This could be either the positive or negative side, depending on which input (IN+ or IN-) is being used for the DC bias. Full unipolar operation is equivalent to a 12-bit converter.

Full Differential Operation - Applying a full differential signal to both the IN(+) and IN(-) inputs is referred to as *full differential operation*. This configuration is described in [Figure 1-5](#).

Pseudo-Differential Operation - Applying a single-ended signal to only one of the input channels with a bipolar output is referred to as *pseudo differential operation*. To obtain a bipolar output from a single-ended input signal the inverting input of the A/D converter must be biased above V_{SS} . This operation is described in [Figure 1-6](#).

Integral Nonlinearity - The maximum deviation from a straight line passing through the endpoints of the bipolar transfer function is defined as the maximum *integral nonlinearity* error. The endpoints of the transfer function are a point 1/2 LSB above the first code transition (0x1000) and 1/2 LSB below the last code transition (0x0FFF).

Differential Nonlinearity - The difference between two measured adjacent code transitions and the 1 LSB ideal is defined as *differential nonlinearity*.

Positive Gain Error - This is the deviation between the last positive code transition (0x0FFF) and the ideal voltage level of $V_{REF}/2$ LSB, after the bipolar offset error has been adjusted out.

Negative Gain Error - This is the deviation between the last negative code transition (0x1000) and the ideal voltage level of $-V_{REF}/2$ LSB, after the bipolar offset error has been adjusted out.

Offset Error - This is the deviation between the first positive code transition (0x0001) and the ideal 1/2 LSB voltage level.

Acquisition Time - The *acquisition time* is defined as the time during which the internal sample capacitor is charging. This occurs for 1.5 clock cycles of the external CLK as defined in [Figure 6-2](#).

Conversion Time - The *conversion time* occurs immediately after the *acquisition time*. During this time, successive approximation of the input signal occurs as the 13-bit result is being calculated by the internal circuitry. This occurs for 13 clock cycles of the external CLK as defined in [Figure 6-2](#).

Signal to Noise Ratio - *Signal to Noise Ratio (SNR)* is defined as the ratio of the signal to noise measured at the output of the converter. The signal is defined as the rms amplitude of the fundamental frequency of the input signal. The noise value is dependant on the device noise as well as the quantization error of the converter and is directly affected by the number of bits in the converter. The *theoretical* signal to noise ratio limit based on quantization error only for an N-bit converter is defined as:

EQUATION

$$SNR = (6.02N + 1.76)dB$$

For a 13-bit converter, the theoretical SNR limit is 80.02 dB.

Total Harmonic Distortion - *Total Harmonic Distortion (THD)* is the ratio of the rms sum of the harmonics to the fundamental, measured at the output of the converter. For the MCP3301, it is defined using the first 9 harmonics, as shown in the following equation:

EQUATION

$$THD(-dB) = -20 \log \frac{\sqrt{V_2^2 + V_3^2 + V_4^2 + \dots + V_8^2 + V_9^2}}{V_1^2}$$

Here V_1 is the rms amplitude of the fundamental and V_2 through V_9 are the rms amplitudes of the second through ninth harmonics.

Signal-to-Noise plus Distortion (SINAD) - Numerically defined, *SINAD* is the calculated combination of SNR and THD. This number represents the dynamic performance of the converter, including any harmonic distortion.

EQUATION

$$SINAD(dB) = 20 \log \sqrt{10^{(SNR/10)} + 10^{-(THD/10)}}$$

Effective Number of Bits - *Effective Number of Bits (ENOB)* states the relative performance of the ADC in terms of its resolution. This term is directly related to SINAD by the following equation:

EQUATION

$$ENOB(N) = \frac{SINAD - 1.76}{6.02}$$

For SINAD performance of 78 dB, the effective number of bits is 12.66.

Spurious Free Dynamic Range - *Spurious Free Dynamic Range (SFDR)* is the ratio of the rms value of the fundamental to the next largest component in the output spectrum of the ADC. This is, typically, the first harmonic, but could also be a noise peak.

MCP3301

5.0 APPLICATIONS INFORMATION

5.1 Conversion Description

The MCP3301 A/D converter employs a conventional SAR architecture. With this architecture, the potential between the IN+ and IN- inputs are simultaneously sampled and stored with the internal sample circuits for 1.5 clock cycles (t_{ACQ}). Following this sample time, the input hold switches of the converter open and the device uses the collected charge to produce a serial 13-bit binary two's complement output code. This conversion process is driven by the external clock and must include 13 clock cycles, one for each bit. During this process, the most significant bit (MSB) is output first. This bit is the sign bit and indicates whether the IN+ input or the IN- input is at a higher potential.

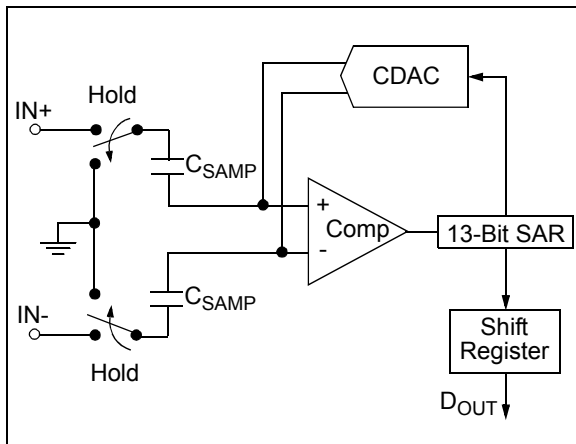

FIGURE 5-1: Simplified Block Diagram.

5.2 Driving the Analog Input

The analog input of the MCP3301 is easily driven either differentially or single ended. Any signal that is common to the two input channels will be rejected by the common mode rejection of the device. During the charging time of the sample capacitor, a small charging current will be required. For low source impedances, this input can be driven directly. For larger source impedances, a larger acquisition time will be required, due to the RC time constant that includes the source impedance. For the A/D Converter to meet specification, the charge holding capacitor (C_{SAMPLE}) must be given enough time to acquire a 13-bit accurate voltage level during the 1.5 clock cycle acquisition period.

An analog input model is shown in Figure 5-3. This model is accurate for an analog input, regardless of whether it is configured as a single-ended input or the IN+ and IN- input in differential mode. In this diagram, it is shown that the source impedance (R_S) adds to the internal sampling switch (R_{SS}) impedance, directly affecting the time that is required to charge the capacitor (C_{SAMPLE}). Consequently, a larger source impedance with no additional acquisition time increases the offset, gain, and integral linearity errors of the conversion. To overcome this, a slower clock speed can be used to allow for the longer charging time. Figure 5-2 shows the maximum clock speed associated with source impedances.

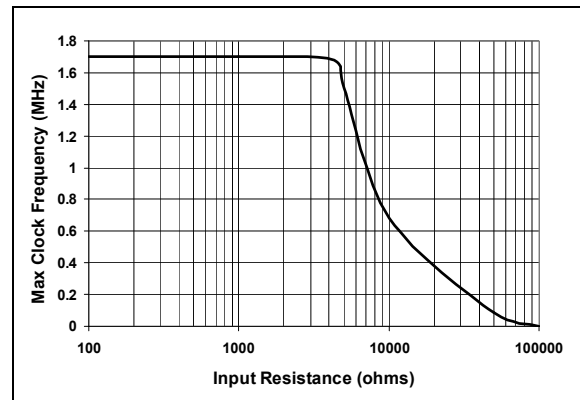

FIGURE 5-2: Maximum Clock Frequency vs. Source Resistance (R_S) to maintain ± 1 LSB INL.

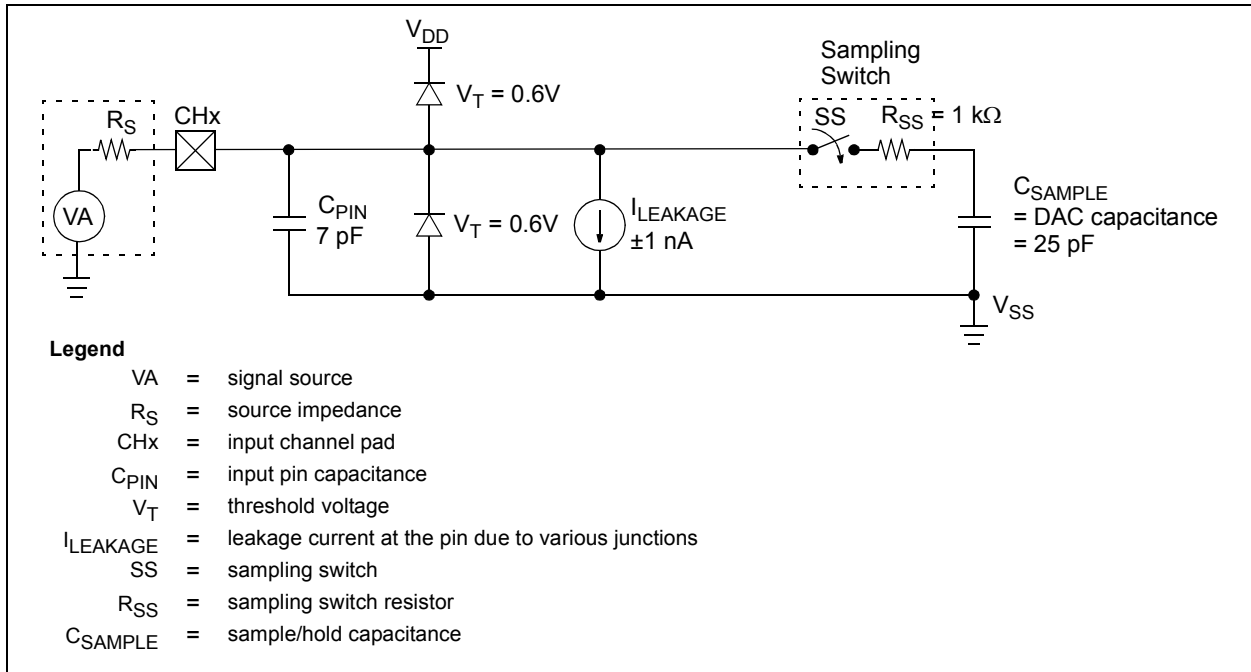

FIGURE 5-3: Analog Input Model.

5.2.1 MAINTAINING MINIMUM CLOCK SPEED

When the MCP3301 initiates, charge is stored on the sample capacitor. When the sample period is complete, the device converts one bit for each clock that is received. It is important for the user to note that a slow clock rate will allow charge to bleed off the sample capacitor while the conversion is taking place. For MCP3301 devices, the recommended minimum clock speed during the conversion cycle (t_{CONV}) is 85 kHz. Failure to meet this criteria may introduce linearity errors into the conversion outside the rated specifications. It should be noted that, during the entire conversion cycle, the A/D converter does not have requirements for clock speed or duty cycle, as long as all timing specifications are met.

5.3 Biasing Solutions

For pseudo-differential bipolar operation, the biasing circuit shown in Figure 5-4 shows a single-ended input AC coupled to the converter. This configuration will give a digital output range of -4096 to +4095. With the 2.5V reference, the LSB size is equal to 610 μ V.

Although the ADC is not production tested with a 2.5V reference as shown, linearity will not change more than 0.1 LSB. See Figure 2-2 and Figure 2-6 for INL and DNL errors versus V_{REF} at $V_{DD} = 5V$. A trade-off exists between the high-pass corner and the acquisition time. The value of C will need to be quite large in order to bring down the high-pass corner. The value of R needs to be 1 k Ω or less, since higher input impedances require additional acquisition time.

Using the values in Figure 5-4, we have a 100 Hz corner frequency. See Figure 5-2 for the relationship between input impedance and acquisition time.

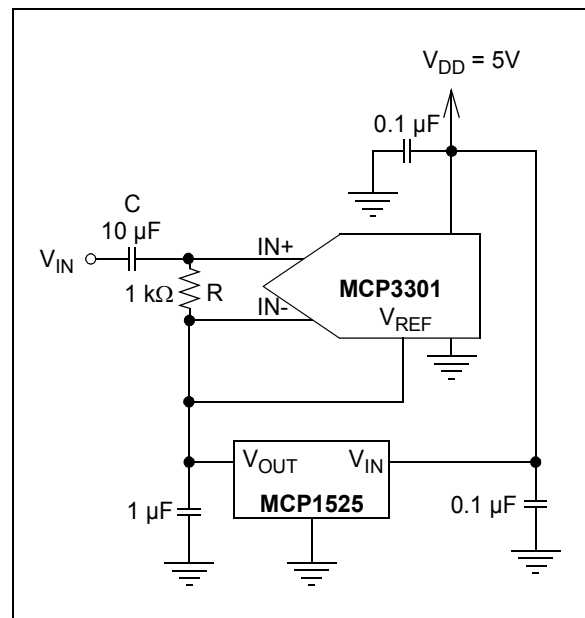

FIGURE 5-4: Pseudo-differential biasing circuit for bipolar operation.

MCP3301

Using an external operational amplifier on the input allows for gain and buffers the input signal from the input to the ADC, allowing for a higher source impedance. This circuit is shown in Figure 5-5.

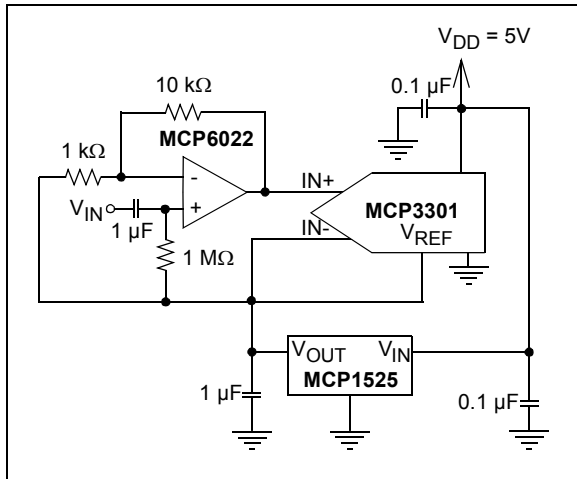

FIGURE 5-5: Adding an amplifier allows for gain and also buffers the input from any high impedance sources.

This circuit shows that some headroom will be lost due to the amplifier output not being able to swing all the way to the rail. An example would be for an output swing of 0V to 5V. This limitation can be overcome by supplying a V_{REF} that is slightly less than the common mode voltage. Using a 2.048V reference for the A/D converter, while biasing the input signal at 2.5V solves the problem. This circuit is shown in Figure 5-6.

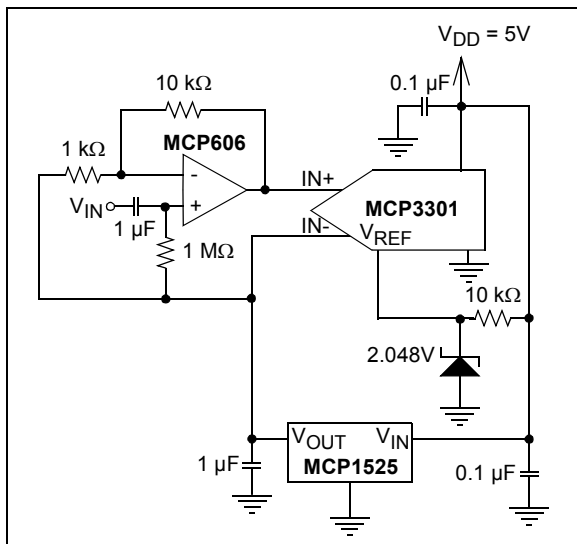

FIGURE 5-6: Circuit solution to overcome amplifier output swing limitation.

5.4 Common Mode Input Range

The *common mode input range* has no restriction and is equal to the absolute input voltage range: $V_{SS} - 0.3V$ to $V_{DD} + 0.3V$. However, for a given V_{REF} , the common mode voltage has a limited swing if the entire range of the A/D converter is to be used. Figure 5-7 and Figure 5-8 show the relationship between V_{REF} and the common mode voltage. A smaller V_{REF} allows for wider flexibility in a common mode voltage. V_{REF} levels, down to 400 mV, exhibit less than 0.1 LSB change in INL and DNL.

For characterization graphs that show this performance relationship, see Figure 2-2 and Figure 2-6.

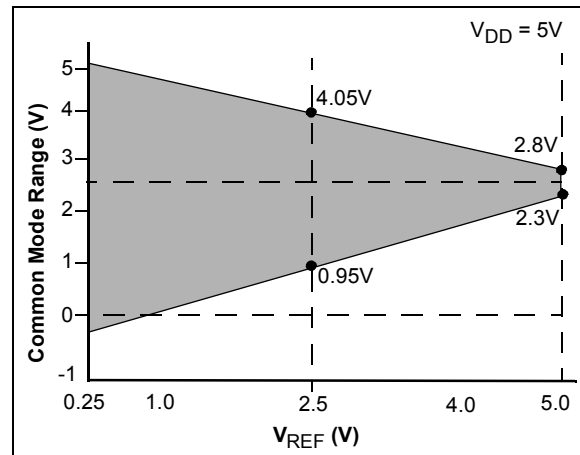

FIGURE 5-7: Common Mode Range of Full Differential input signal versus V_{REF} .

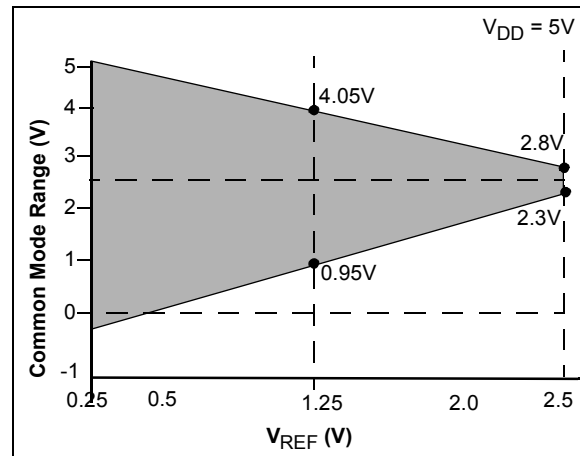

FIGURE 5-8: Common Mode Range versus V_{REF} for Pseudo Differential Input.

5.5 Buffering/Filtering the Analog Inputs

Inaccurate conversion results may occur if the signal source for the A/D converter is not a low impedance source. Buffering the input will solve the impedance issue. It is also recommended that an analog filter be used to eliminate any signals that may be aliased back into the conversion results. Using an op amp to drive the analog input of the MCP3301 is illustrated in Figure 5-9. This amplifier provides a low impedance source for the converter input and low pass filter, which eliminates unwanted high frequency noise. Values shown are for a 10 Hz Butterworth Low pass filter.

Low pass (anti-aliasing) filters can be designed using Microchip's interactive FilterLab® software. FilterLab will calculate capacitor and resistor values as well as determine the number of poles that are required for the application. For more information on filtering signals, see AN-699 "Anti-Aliasing Analog Filters for Data Acquisition Systems".

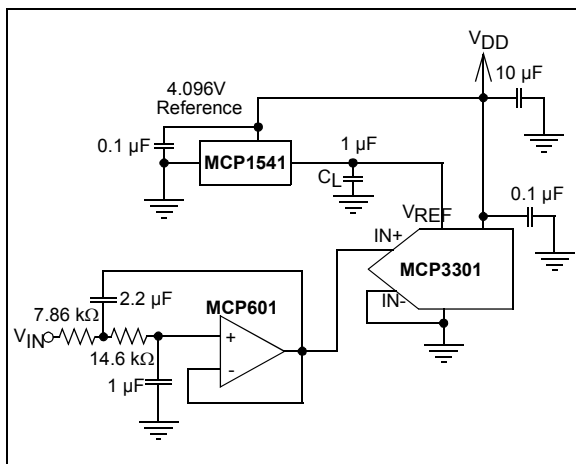

FIGURE 5-9: The MCP601 Operational Amplifier is used to implement a 2nd order anti-aliasing filter for the signal being converted by the MCP3301.

5.6 Layout Considerations

When laying out a printed circuit board for use with analog components, care should be taken to reduce noise wherever possible. A bypass capacitor from V_{DD} to ground should always be used with this device and should be placed as close as possible to the device pin. A bypass capacitor value of 0.1 μF is recommended.

Digital and analog traces should be separated as much as possible on the board with no traces running underneath the device or bypass capacitor. Extra precautions should be taken to keep traces with high frequency signals (such as clock lines) as far as possible from analog traces.

Use of an analog ground plane is recommended in order to keep the ground potential the same for all devices on the board. Providing V_{DD} connections to devices in a "star" configuration can also reduce noise by eliminating current return paths and associated errors (Figure 5-10). For more information on layout tips when using the MCP3301 or other ADC devices, refer to AN-688 "Layout Tips for 12-Bit A/D Converter Applications".

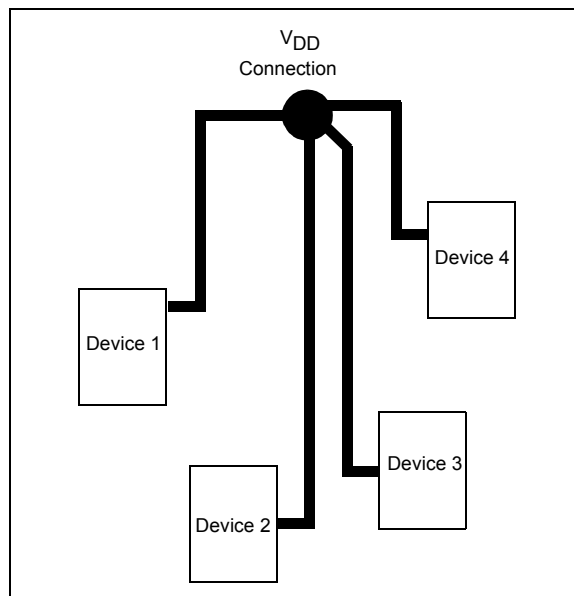

FIGURE 5-10: V_{DD} traces arranged in a 'Star' configuration in order to reduce errors caused by current return paths. MCP3301

MCP3301

6.0 SERIAL COMMUNICATIONS

6.1 Output Code Format

The output code format is a binary two's complement scheme with a leading sign bit that indicates the sign of the output. If the IN+ input is higher than the IN- input, the sign bit will be a zero. If the IN- input is higher, the sign bit will be a '1'.

The diagram shown in [Figure 6-1](#) shows the output code transfer function. In this diagram, the horizontal axis is the analog input voltage and the vertical axis is the output code of the ADC. It shows that when IN+ is equal to IN-, both the sign bit and the data word are zero. As IN+ gets larger, with respect to IN-, the sign bit is a zero and the data word gets larger. The full scale output code is reached at +4095 when the input [(IN+) - (IN-)] reaches $V_{REF} - 1$ LSB. When IN- is larger than IN+, the two's complement output codes will be seen with the sign bit being a one. Some examples of analog input levels and corresponding output codes are shown in [Table 6-1](#).

TABLE 6-1: BINARY TWO'S COMPLEMENT OUTPUT CODE EXAMPLES.

Analog Input Levels		Sign Bit	Binary Data	Decimal DATA
Full Scale Positive	$(IN^+) - (IN^-) = V_{REF} - 1$ LSB	0	1111 1111 1111	+4095
	$(IN^+) - (IN^-) = V_{REF} - 2$ LSB	0	1111 1111 1110	+4094
	$IN^+ = (IN^-) + 2$ LSB	0	0000 0000 0010	+2
	$IN^+ = (IN^-) + 1$ LSB	0	0000 0000 0001	+1
	$IN^+ = IN^-$	0	0000 0000 0000	0
	$IN^+ = (IN^-) - 1$ LSB	1	1111 1111 1111	-1
	$IN^+ = (IN^-) - 2$ LSB	1	1111 1111 1110	-2
	$IN^+ - IN^- = V_{REF} + 1$ LSB	1	0000 0000 0001	-4095
Full Scale Negative	$IN^+ - IN^- = -V_{REF}$	1	0000 0000 0000	-4096

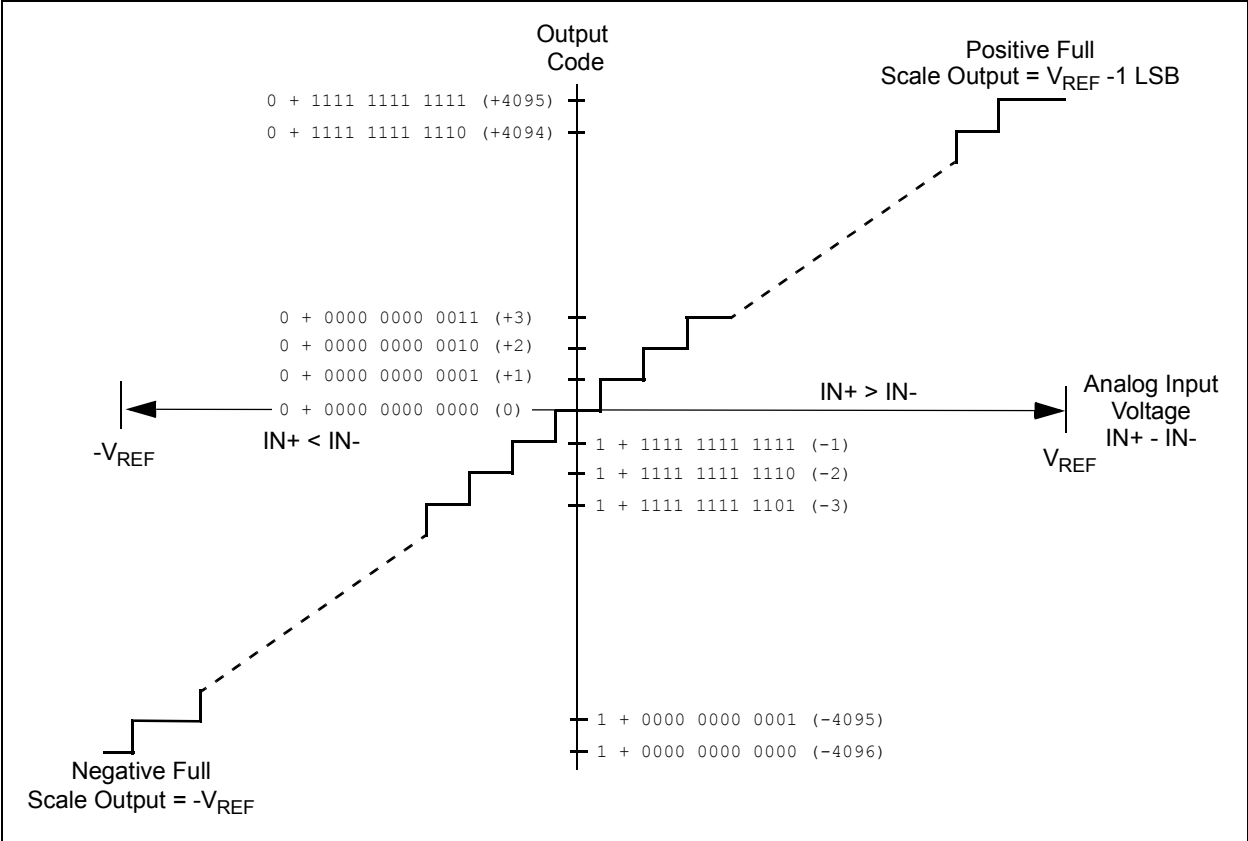

FIGURE 6-1: Output Code Transfer Function.

MCP3301

6.2 Communicating with the MCP3301

Communication with the device is completed using a standard SPI compatible serial interface. Initiating communication with the MCP3301 begins with the \overline{CS} going low. If the device was powered up with the \overline{CS} pin low, it must be brought high and back low to initiate communication. The device will begin to sample the analog input on the first rising edge of CLK after \overline{CS} goes low. The sample period will end in the falling edge of the second clock, at which time the device will output a low null bit. The next 13 clocks will output the result of the conversion with the sign bit first, followed by the

12 remaining data bits, as shown in Figure 6-2. Data is always output from the device on the falling edge of the clock. If all 13 data bits have been transmitted and the device continues to receive clocks while the \overline{CS} is held low, the device will output the conversion result LSB first, as shown in Figure 6-3. If more clocks are provided to the device while \overline{CS} is still low (after the LSB first data has been transmitted), the device will clock out zeros indefinitely.

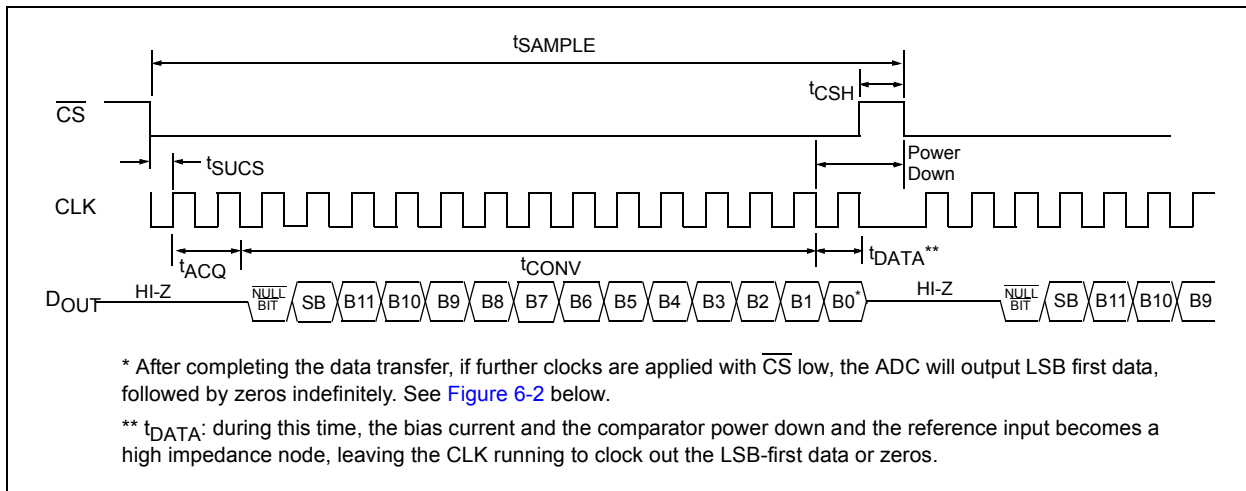

FIGURE 6-2: Communication with MCP3301 (MSB first Format).

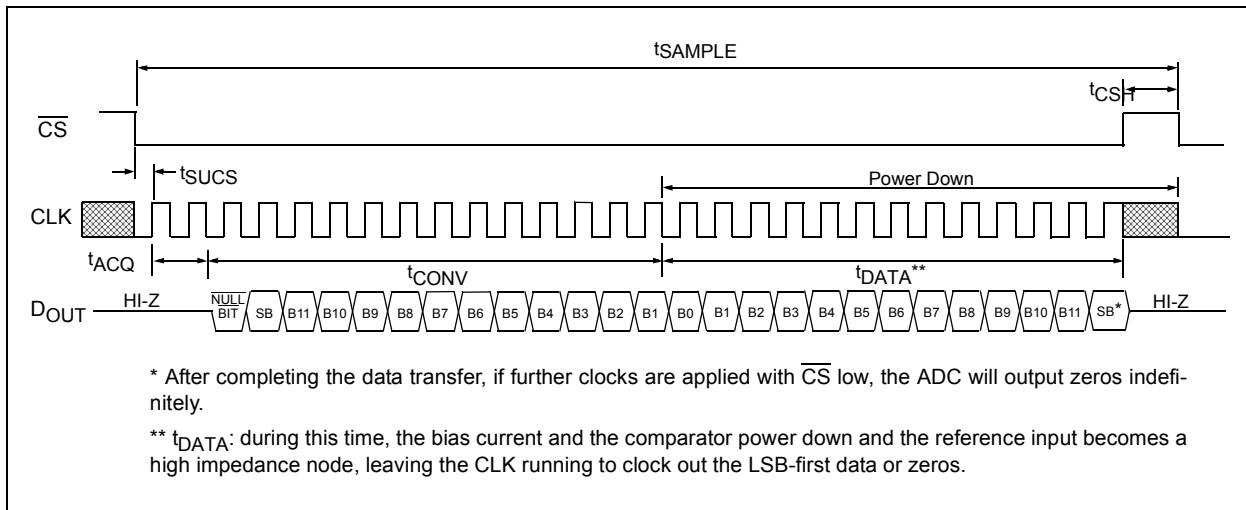

FIGURE 6-3: Communication with MCP3301 (LSB first Format).

6.3 Using the MCP3301 with Microcontroller (MCU) SPI Ports

With most microcontroller SPI ports, it is required to clock out eight bits at a time. Using a hardware SPI port with the MCP3301 is very easy because each conversion requires 16 clocks. For example, [Figure 6-4](#) and [Figure 6-5](#) show how the MCP3301 can be interfaced to a microcontroller with a standard SPI port. Since the MCP3301 always clocks data out on the falling edge of clock, the MCU SPI port must be configured to match this operation. SPI Mode 0,0 (clock idles low) and SPI Mode 1,1 (clock idles high) are both compatible with the MCP3301. [Figure 6-4](#) depicts the operation shown in SPI Mode 0,0, which requires that the CLK from the microcontroller idles in the 'low' state. As shown in the diagram, the sign bit is clocked out of the ADC on the

falling edge of the third clock pulse, followed by the remaining 12 data bits (MSB first). Once the first eight clocks have been sent to the device, the microcontroller's receive buffer will contain two unknown bits (for the first two clocks, the output is high impedance), followed by the null bit and the highest order four bits of the conversion. After the second eight clocks have been sent to the device, the MCU receive register will contain the lowest order 8 data bits. Notice that, on the falling edge of clock 16, the ADC has begun to shift out LSB first data.

[Figure 6-5](#) shows the same scenario in SPI Mode 1,1, which requires that the clock idles in the high state. As with mode 0,0, the ADC outputs data on the falling edge of the clock and the MCU latches data from the ADC in on the rising edge of the clock.

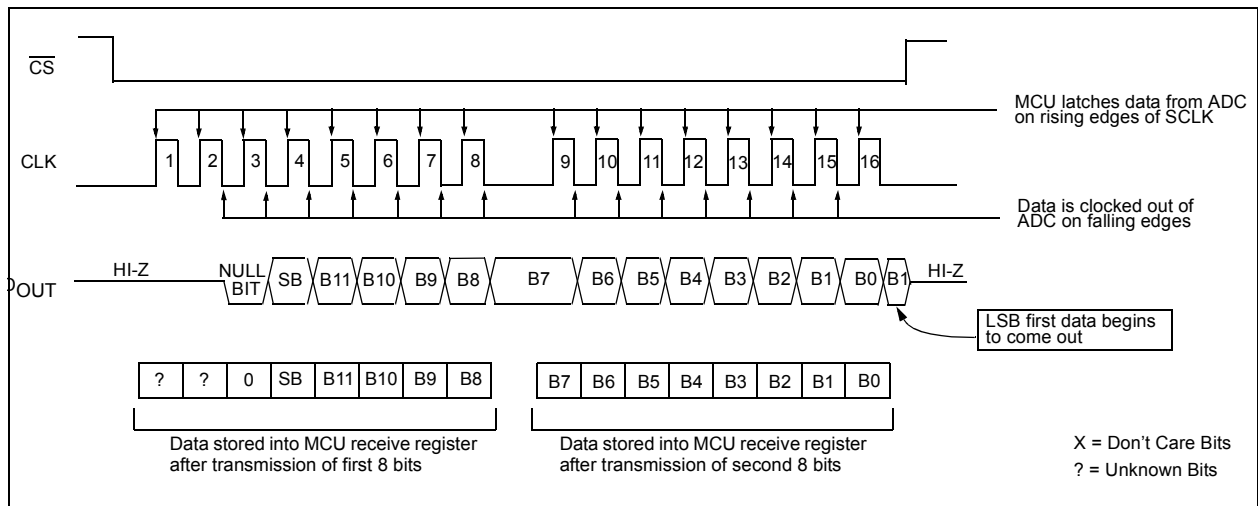

FIGURE 6-4: SPI Communication with the MCP3301 using 8-bit segments (Mode 0,0: SCLK idles low).

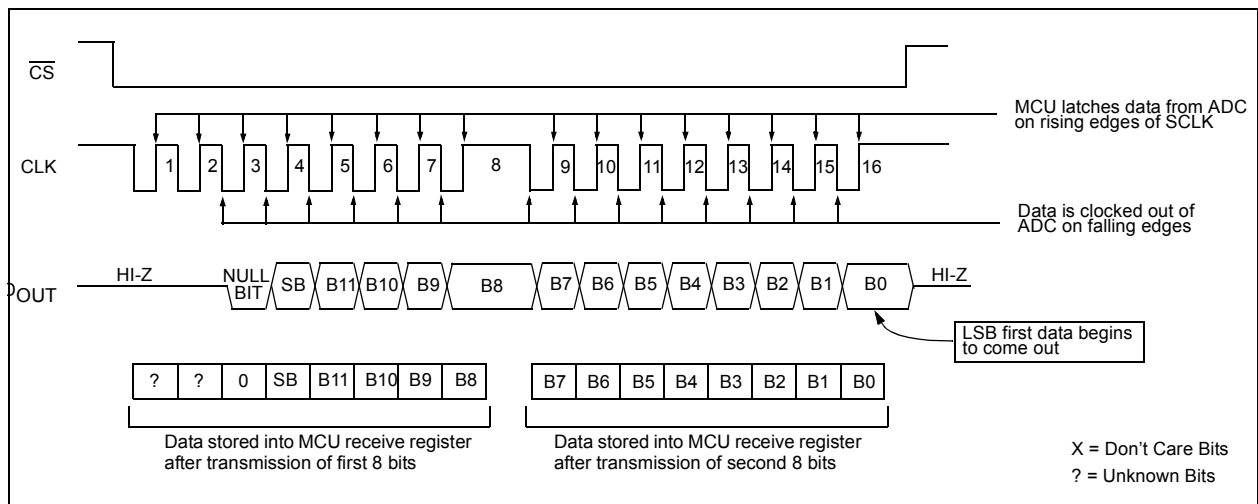

FIGURE 6-5: SPI Communication with the MCP3301 using 8-bit segments (Mode 1,1: SCLK idles high).

MCP3301

7.0 PACKAGING INFORMATION

7.1 Package Marking Information

8-Lead MSOP (3x3 mm)

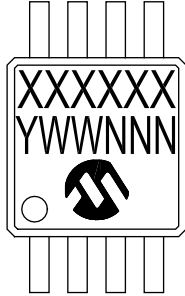

Example



8-Lead PDIP (300 mil)

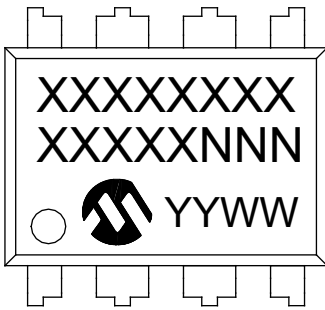

Example

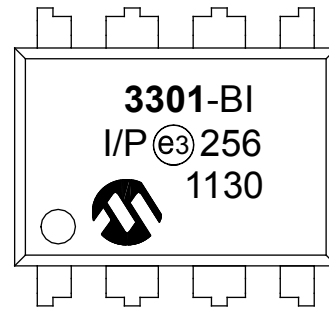

8-Lead SOIC (3.90 mm)

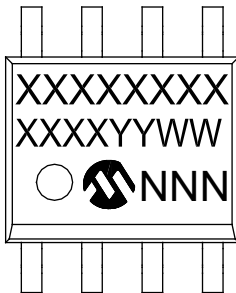

Example

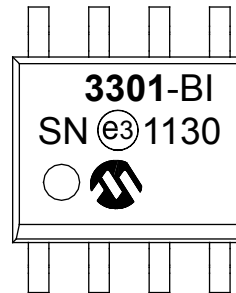

Legend:	XX...X	Customer-specific information
	Y	Year code (last digit of calendar year)
	YY	Year code (last 2 digits of calendar year)
	WW	Week code (week of January 1 is week '01')
	NNN	Alphanumeric traceability code
	e3	Pb-free JEDEC designator for Matte Tin (Sn)
	*	This package is Pb-free. The Pb-free JEDEC designator (e3) can be found on the outer packaging for this package.

Note: In the event the full Microchip part number cannot be marked on one line, it will be carried over to the next line, thus limiting the number of available characters for customer-specific information.

8-Lead Plastic Micro Small Outline Package (MS) [MSOP]

Note: For the most current package drawings, please see the Microchip Packaging Specification located at <http://www.microchip.com/packaging>

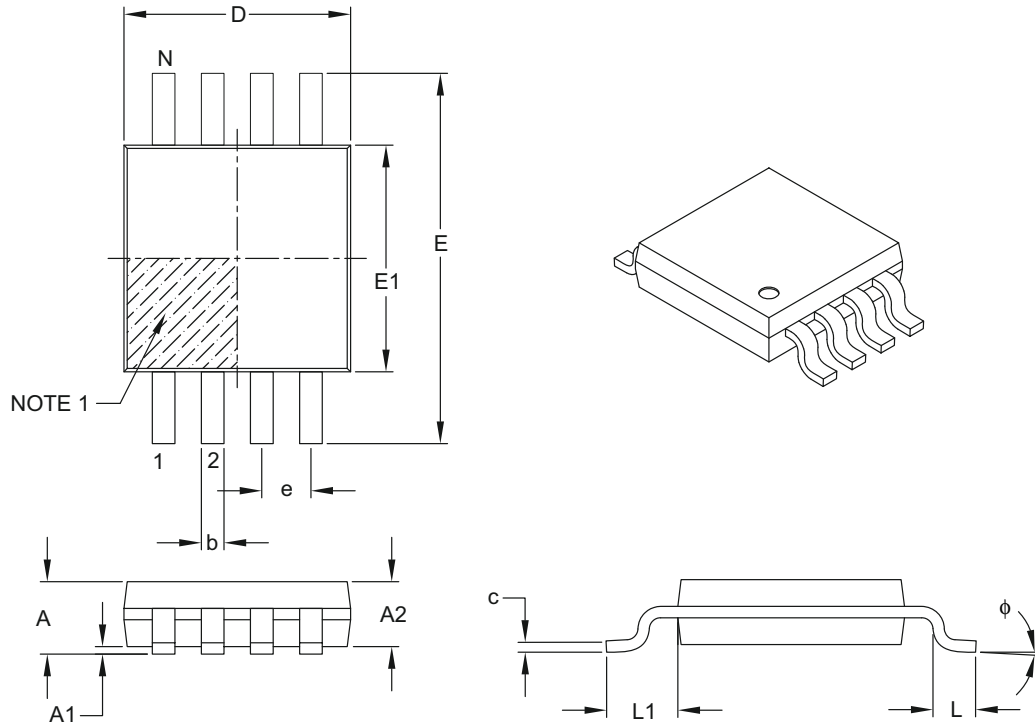

Dimension Limits	Units	MILLIMETERS		
		MIN	NOM	MAX
Number of Pins	N	8		
Pitch	e	0.65 BSC		
Overall Height	A	–	–	1.10
Molded Package Thickness	A2	0.75	0.85	0.95
Standoff	A1	0.00	–	0.15
Overall Width	E	4.90 BSC		
Molded Package Width	E1	3.00 BSC		
Overall Length	D	3.00 BSC		
Foot Length	L	0.40	0.60	0.80
Footprint	L1	0.95 REF		
Foot Angle	ϕ	0°	–	8°
Lead Thickness	c	0.08	–	0.23
Lead Width	b	0.22	–	0.40

Notes:

- Pin 1 visual index feature may vary, but must be located within the hatched area.
- Dimensions D and E1 do not include mold flash or protrusions. Mold flash or protrusions shall not exceed 0.15 mm per side.
- Dimensioning and tolerancing per ASME Y14.5M.

BSC: Basic Dimension. Theoretically exact value shown without tolerances.

REF: Reference Dimension, usually without tolerance, for information purposes only.

Microchip Technology Drawing C04-111B

MCP3301

8-Lead Plastic Micro Small Outline Package (MS) [MSOP]

Note: For the most current package drawings, please see the Microchip Packaging Specification located at <http://www.microchip.com/packaging>

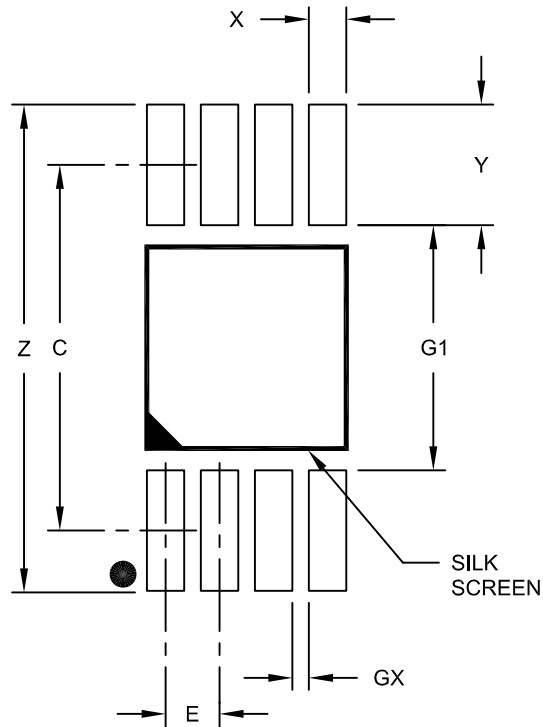

RECOMMENDED LAND PATTERN

Dimension Limits	Units	MILLIMETERS		
		MIN	NOM	MAX
Contact Pitch	E	0.65 BSC		
Contact Pad Spacing	C		4.40	
Overall Width	Z			5.85
Contact Pad Width (X8)	X1			0.45
Contact Pad Length (X8)	Y1			1.45
Distance Between Pads	G1	2.95		
Distance Between Pads	GX	0.20		

Notes:

1. Dimensioning and tolerancing per ASME Y14.5M

BSC: Basic Dimension. Theoretically exact value shown without tolerances.

Microchip Technology Drawing No. C04-2111A

8-Lead Plastic Dual In-Line (P) – 300 mil Body [PDIP]

Note: For the most current package drawings, please see the Microchip Packaging Specification located at <http://www.microchip.com/packaging>

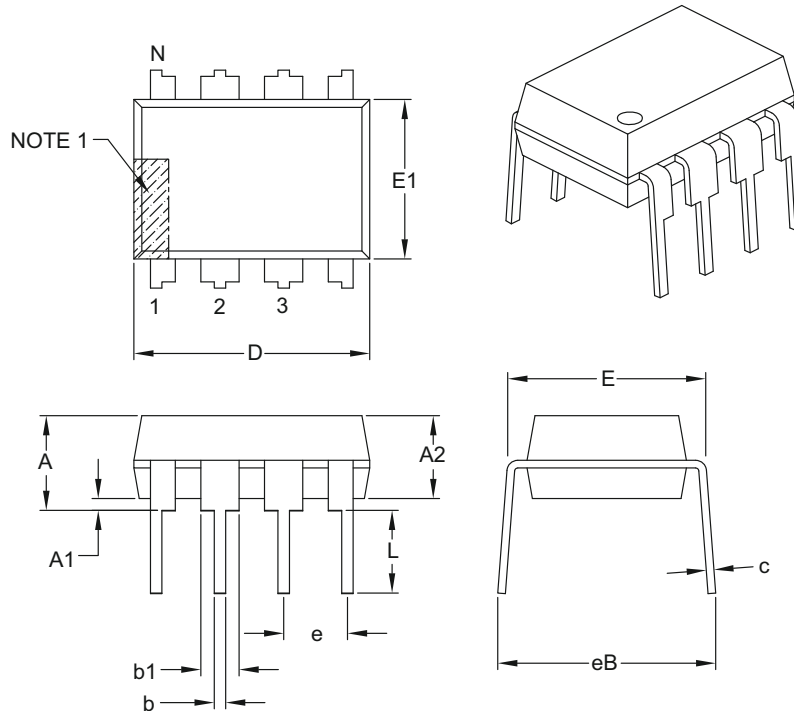

Dimension Limits	Units	INCHES		
		MIN	NOM	MAX
Number of Pins	N	8		
Pitch	e	.100 BSC		
Top to Seating Plane	A	–	–	.210
Molded Package Thickness	A2	.115	.130	.195
Base to Seating Plane	A1	.015	–	–
Shoulder to Shoulder Width	E	.290	.310	.325
Molded Package Width	E1	.240	.250	.280
Overall Length	D	.348	.365	.400
Tip to Seating Plane	L	.115	.130	.150
Lead Thickness	c	.008	.010	.015
Upper Lead Width	b1	.040	.060	.070
Lower Lead Width	b	.014	.018	.022
Overall Row Spacing §	eB	–	–	.430

Notes:

- Pin 1 visual index feature may vary, but must be located with the hatched area.
- § Significant Characteristic.
- Dimensions D and E1 do not include mold flash or protrusions. Mold flash or protrusions shall not exceed .010" per side.
- Dimensioning and tolerancing per ASME Y14.5M.

BSC: Basic Dimension. Theoretically exact value shown without tolerances.

Microchip Technology Drawing C04-018B