



Chipsmall Limited consists of a professional team with an average of over 10 year of expertise in the distribution of electronic components. Based in Hongkong, we have already established firm and mutual-benefit business relationships with customers from,Europe,America and south Asia,supplying obsolete and hard-to-find components to meet their specific needs.

With the principle of “Quality Parts,Customers Priority,Honest Operation,and Considerate Service”,our business mainly focus on the distribution of electronic components. Line cards we deal with include Microchip,ALPS,ROHM,Xilinx,Pulse,ON,Everlight and Freescale. Main products comprise IC,Modules,Potentiometer,IC Socket,Relay,Connector.Our parts cover such applications as commercial,industrial, and automotives areas.

We are looking forward to setting up business relationship with you and hope to provide you with the best service and solution. Let us make a better world for our industry!



Contact us

Tel: +86-755-8981 8866 Fax: +86-755-8427 6832

Email & Skype: info@chipsmall.com Web: www.chipsmall.com

Address: A1208, Overseas Decoration Building, #122 Zhenhua RD., Futian, Shenzhen, China



Low-Cost NV Digital POT with WiperLock™ Technology

Features

- Non-volatile Digital Potentiometer in SOT-23, SOIC, MSOP and DFN packages
- 64 Taps: 63 Resistors with Taps to terminal A and terminal B
- Simple Up/Down (U/D) Protocol
- Power-on Recall of Saved Wiper Setting
- Resistance Values: 2.1 kΩ, 5 kΩ, 10 kΩ or 50 kΩ
- Low Tempco:
 - Absolute (Rheostat): 50 ppm (0°C to 70°C typ.)
 - Ratiometric (Potentiometer): 10 ppm (typ.)
- Low Wiper Resistance: 75Ω (typ.)
- WiperLock™ Technology to Secure the wiper setting in non-volatile memory (EEPROM)
- High-Voltage Tolerant Digital Inputs: Up to 12.5V
- Low-Power Operation: 1 μA Max Static Current
- Wide Operating Voltage: 2.7V to 5.5V
- Extended Temperature Range: -40°C to +125°C
- Wide Bandwidth (-3 dB) Operation:
 - 4 MHz (typ.) for 2.1 kΩ device

Description

The MCP4021/2/3/4 devices are non-volatile, 6-bit digital potentiometers that can be configured as either a potentiometer or rheostat. The wiper setting is controlled through a simple Up/Down (U/D) serial interface.

These device's implement Microchip's WiperLock technology, which allows application-specific calibration settings to be secured in the EEPROM without requiring the use of an additional write-protect pin.

Package Types

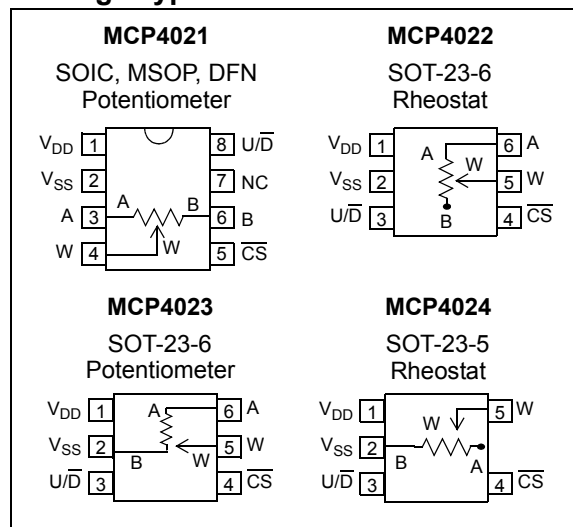

Block Diagram

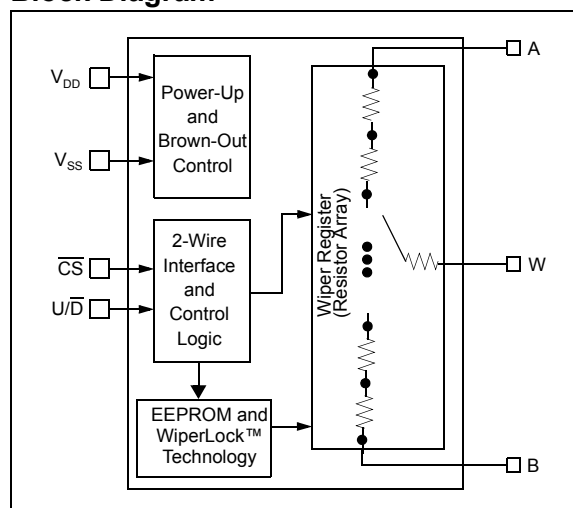

Device Features

Device	Wiper Configuration	Memory Type	Resistance (typical)		# of Steps	V _{DD} Operating Range	Control Interface	WiperLock™ Technology
			Options (kΩ)	Wiper (Ω)				
MCP4021	Potentiometer ⁽¹⁾	EE	2.1, 5.0, 10.0, 50.0	75	64	2.7V - 5.5V	U/D	Yes
MCP4022	Rheostat	EE	2.1, 5.0, 10.0, 50.0	75	64	2.7V - 5.5V	U/D	Yes
MCP4023	Potentiometer	EE	2.1, 5.0, 10.0, 50.0	75	64	2.7V - 5.5V	U/D	Yes
MCP4024	Rheostat	EE	2.1, 5.0, 10.0, 50.0	75	64	2.7V - 5.5V	U/D	Yes

Note 1: Floating either terminal (A or B) allows the device to be used in Rheostat mode.

MCP4021/2/3/4

1.0 ELECTRICAL CHARACTERISTICS

Absolute Maximum Ratings †

V_{DD}	6.5V
\overline{CS} and U/\overline{D} inputs w.r.t V_{SS}	-0.3V to 12.5V
A, B and W terminals w.r.t V_{SS}	-0.3V to $V_{DD} + 0.3V$
Current at Input Pins	± 10 mA
Current at Supply Pins	± 10 mA
Current at Potentiometer Pins	± 2.5 mA
Storage temperature	-65°C to +150°C
Ambient temp. with power applied	-55°C to +125°C
ESD protection on all pins	≥ 4 kV (HBM), $\geq 400V$ (MM)
Maximum Junction Temperature (T_J).....	+150°C

† **Notice:** Stresses above those listed under “Maximum Ratings” may cause permanent damage to the device. This is a stress rating only and functional operation of the device at those or any other conditions above those indicated in the operational listings of this specification is not implied. Exposure to maximum rating conditions for extended periods may affect device reliability.

AC/DC CHARACTERISTICS

Electrical Specifications: Unless otherwise indicated, all parameters apply across the specified operating ranges. $T_A = -40^\circ\text{C}$ to $+125^\circ\text{C}$, 2.1 k Ω , 5 k Ω , 10 k Ω and 50 k Ω devices. Typical specifications represent values for $V_{DD} = 5.5V$, $V_{SS} = 0V$, $T_A = +25^\circ\text{C}$.						
Parameters	Sym	Min	Typ	Max	Units	Conditions
Operating Voltage Range	V_{DD}	2.7	—	5.5	V	
\overline{CS} Input Voltage	V_{CS}	V_{SS}	—	12.5	V	The \overline{CS} pin will be at one of three input levels (V_{IL} , V_{IH} or V_{IHH}). (Note 6)
Supply Current	I_{DD}	—	45	—	μA	5.5V, $\overline{CS} = V_{SS}$, $f_{U/\overline{D}} = 1$ MHz
		—	15	—	μA	2.7V, $\overline{CS} = V_{SS}$, $f_{U/\overline{D}} = 1$ MHz
		—	0.3	1	μA	Serial Interface Inactive ($\overline{CS} = V_{IH}$, $U/\overline{D} = V_{IH}$)
		—	0.6	3	mA	EE Write cycle, $T_A = +25^\circ\text{C}$
Resistance ($\pm 20\%$)	R_{AB}	1.68	2.1	2.52	k Ω	-202 devices (Note 1)
		4.0	5	6.0	k Ω	-502 devices (Note 1)
		8.0	10	12.0	k Ω	-103 devices (Note 1)
		40.0	50	60.0	k Ω	-503 devices (Note 1)
Resolution	N	64			Taps	No Missing Codes
Step Resistance	R_S	—	$R_{AB} / 63$	—	Ω	Note 6

- Note 1:** Resistance is defined as the resistance between terminal A to terminal B.
Note 2: INL and DNL are measured at V_W with $V_A = V_{DD}$ and $V_B = V_{SS}$. (-202 devices $V_A = 4V$).
Note 3: MCP4021/23 only, test conditions are: $I_W = 1.9$ mA, code = 00h.
Note 4: MCP4022/24 only, test conditions are:

Device Resistance	Current at Voltage		Comments
	5.5V	2.7V	
2.1 k Ω	2.25 mA	1.1 mA	MCP4022 includes V_{WZSE} MCP4024 includes V_{WFSE}
5 k Ω	1.4 mA	450 μA	
10 k Ω	450 μA	210 μA	
50 k Ω	90 μA	40 μA	

- Note 5:** Resistor terminals A, W and B's polarity with respect to each other is not restricted.
Note 6: This specification by design
Note 7: Non-linearity is affected by wiper resistance (R_W), which changes significantly over voltage and temperature. See **Section 6.0 “Resistor”** for additional information.
Note 8: The MCP4021 is externally connected to match the configurations of the MCP4022 and MCP4024, and then tested.

AC/DC CHARACTERISTICS (CONTINUED)

Electrical Specifications: Unless otherwise indicated, all parameters apply across the specified operating ranges.

$T_A = -40^\circ\text{C}$ to $+125^\circ\text{C}$, 2.1 k Ω , 5 k Ω , 10 k Ω and 50 k Ω devices. Typical specifications represent values for $V_{DD} = 5.5\text{V}$, $V_{SS} = 0\text{V}$, $T_A = +25^\circ\text{C}$.

Parameters	Sym	Min	Typ	Max	Units	Conditions	
Wiper Resistance (Note 3, Note 4)	R_W	—	70	125	Ω	5.5V	
		—	70	325	Ω	2.7V	
Nominal Resistance Tempco	$\Delta R/\Delta T$	—	50	—	ppm/ $^\circ\text{C}$	$T_A = -20^\circ\text{C}$ to $+70^\circ\text{C}$	
		—	100	—	ppm/ $^\circ\text{C}$	$T_A = -40^\circ\text{C}$ to $+85^\circ\text{C}$	
		—	150	—	ppm/ $^\circ\text{C}$	$T_A = -40^\circ\text{C}$ to $+125^\circ\text{C}$	
Ratiometric Tempco	$\Delta V_{WA}/\Delta T$	—	10	—	ppm/ $^\circ\text{C}$	MCP4021 and MCP4023 only, code = 1Fh	
Full-Scale Error	V_{WFSE}	-0.5	-0.1	+0.5	LSb	Code 3Fh (MCP4021/23 only)	
Zero-Scale Error	V_{WZSE}	-0.5	+0.1	+0.5	LSb	Code 00h (MCP4021/23 only)	
Monotonicity	N	Yes			Bits		
Potentiometer Integral Non-linearity	INL	-0.5	± 0.25	+0.5	LSb	MCP4021/23 only (Note 2)	
Potentiometer Differential Non-linearity	DNL	-0.5	± 0.25	+0.5	LSb	MCP4021/23 only (Note 2)	
Resistor Terminal Input Voltage Range (Terminals A, B and W)	V_A, V_W, V_B	V_{SS}	—	V_{DD}	V	Note 5, Note 6	
Maximum current through A, W or B	I_W	—	—	2.5	mA	Note 6	
Leakage current into A, W or B	I_{WL}	—	100	—	nA	MCP4021 A = W = B = V_{SS}	
		—	100	—	nA	MCP4022/23 A = W = V_{SS}	
		—	100	—	nA	MCP4024 W = V_{SS}	
Capacitance (P_A)	C_{AW}	—	75	—	pF	f = 1 MHz, code = 1Fh	
Capacitance (P_W)	C_W	—	120	—	pF	f = 1 MHz, code = 1Fh	
Capacitance (P_B)	C_{BW}	—	75	—	pF	f = 1 MHz, code = 1Fh	
Bandwidth -3 dB	BW	—	4	—	MHz	-202 devices	Code = 1F, output load = 30 pF
		—	2	—	MHz	-502 devices	
		—	1	—	MHz	-103 devices	
		—	200	—	kHz	-503 devices	

- Note 1:** Resistance is defined as the resistance between terminal A to terminal B.
Note 2: INL and DNL are measured at V_W with $V_A = V_{DD}$ and $V_B = V_{SS}$. (-202 devices $V_A = 4\text{V}$).
Note 3: **MCP4021/23** only, test conditions are: $I_W = 1.9\text{ mA}$, code = 00h.
Note 4: **MCP4022/24** only, test conditions are:

Device Resistance	Current at Voltage		Comments
	5.5V	2.7V	
2.1 k Ω	2.25 mA	1.1 mA	MCP4022 includes V_{WZSE} MCP4024 includes V_{WFSE}
5 k Ω	1.4 mA	450 μA	
10 k Ω	450 μA	210 μA	
50 k Ω	90 μA	40 μA	

- 5:** Resistor terminals A, W and B's polarity with respect to each other is not restricted.
6: This specification by design
7: Non-linearity is affected by wiper resistance (R_W), which changes significantly over voltage and temperature. See **Section 6.0 "Resistor"** for additional information.
8: The **MCP4021** is externally connected to match the configurations of the **MCP4022** and **MCP4024**, and then tested.

MCP4021/2/3/4

AC/DC CHARACTERISTICS (CONTINUED)

Electrical Specifications: Unless otherwise indicated, all parameters apply across the specified operating ranges.
 $T_A = -40^\circ\text{C}$ to $+125^\circ\text{C}$, 2.1 k Ω , 5 k Ω , 10 k Ω and 50 k Ω devices. Typical specifications represent values for $V_{DD} = 5.5\text{V}$, $V_{SS} = 0\text{V}$, $T_A = +25^\circ\text{C}$.

Parameters	Sym	Min	Typ	Max	Units	Conditions	
Rheostat Integral Non-linearity MCP4021 (Note 4, Note 8) MCP4022 and MCP4024 (Note 4)	R-INL	-0.5	± 0.25	+0.5	LSb	-202 devices (2.1 k Ω)	5.5V
		-8.5	+4.5	+8.5	LSb		2.7V (Note 7)
		-0.5	± 0.25	+0.5	LSb	-502 devices (5 k Ω)	5.5V
		-5.5	+2.5	+5.5	LSb		2.7V (Note 7)
		-0.5	± 0.25	+0.5	LSb	-103 devices (10 k Ω)	5.5V
		-3	+1	+3	LSb		2.7V (Note 7)
		-0.5	± 0.25	+0.5	LSb	-503 devices (50 k Ω)	5.5V
		-1	+0.25	+1	LSb		2.7V (Note 7)
Rheostat Differential Non-linearity MCP4021 (Note 4, Note 8) MCP4022 and MCP4024 (Note 4)	R-DNL	-0.5	± 0.25	+0.5	LSb	-202 devices (2.1 k Ω)	5.5V
		-1	+0.5	+2	LSb		2.7V (Note 7)
		-0.5	± 0.25	+0.5	LSb	-502 devices (5 k Ω)	5.5V
		-1	+0.25	+1.25	LSb		2.7V (Note 7)
		-0.5	± 0.25	+0.5	LSb	-103 devices (10 k Ω)	5.5V
		-1	0	+1	LSb		2.7V (Note 7)
		-0.5	± 0.25	+0.5	LSb	-503 devices (50 k Ω)	5.5V
		-0.5	0	+0.5	LSb		2.7V (Note 7)

- Note** 1: Resistance is defined as the resistance between terminal A to terminal B.
 2: INL and DNL are measured at V_W with $V_A = V_{DD}$ and $V_B = V_{SS}$. (-202 devices $V_A = 4\text{V}$).
 3: **MCP4021/23** only, test conditions are: $I_W = 1.9\text{ mA}$, code = 00h.
 4: **MCP4022/24** only, test conditions are:

Device Resistance	Current at Voltage		Comments
	5.5V	2.7V	
2.1 k Ω	2.25 mA	1.1 mA	MCP4022 includes V_{WZSE} MCP4024 includes V_{WFSE}
5 k Ω	1.4 mA	450 μA	
10 k Ω	450 μA	210 μA	
50 k Ω	90 μA	40 μA	

- 5: Resistor terminals A, W and B's polarity with respect to each other is not restricted.
 6: This specification by design
 7: Non-linearity is affected by wiper resistance (R_W), which changes significantly over voltage and temperature. See **Section 6.0 "Resistor"** for additional information.
 8: The **MCP4021** is externally connected to match the configurations of the **MCP4022** and **MCP4024**, and then tested.

AC/DC CHARACTERISTICS (CONTINUED)

Electrical Specifications: Unless otherwise indicated, all parameters apply across the specified operating ranges. $T_A = -40^\circ\text{C}$ to $+125^\circ\text{C}$, 2.1 k Ω , 5 k Ω , 10 k Ω and 50 k Ω devices. Typical specifications represent values for $V_{DD} = 5.5\text{V}$, $V_{SS} = 0\text{V}$, $T_A = +25^\circ\text{C}$.

Parameters	Sym	Min	Typ	Max	Units	Conditions
Digital Inputs/Outputs (CS, U/D)						
Input High Voltage	V_{IH}	$0.7 V_{DD}$	—	—	V	
Input Low Voltage	V_{IL}	—	—	$0.3 V_{DD}$	V	
High-Voltage Input Entry Voltage	V_{IHH}	8.5	—	12.5 ⁽⁶⁾	V	Threshold for WiperLock™ Technology
High-Voltage Input Exit Voltage	V_{IHH}	—	—	$V_{DD}+0.8$ ⁽⁶⁾	V	
$\overline{\text{CS}}$ Pull-up/Pull-down Resistance	R_{CS}	—	16	—	k Ω	$V_{DD} = 5.5\text{V}$, $V_{CS} = 3\text{V}$
$\overline{\text{CS}}$ Weak Pull-up/Pull-down Current	I_{PU}	—	170	—	μA	$V_{DD} = 5.5\text{V}$, $V_{CS} = 3\text{V}$
Input Leakage Current	I_{IL}	-1	—	1	μA	$V_{IN} = V_{DD}$
$\overline{\text{CS}}$ and U/D Pin Capacitance	C_{IN} , C_{OUT}	—	10	—	pF	$f_C = 1\text{MHz}$
RAM (Wiper) Value						
Value Range	N	0h	—	3Fh	hex	
EEPROM						
Endurance	$E_{ndurance}$	—	1M	—	Cycles	
EEPROM Range	N	0h	—	3Fh	hex	
Initial Factory Setting	N	1Fh			hex	WiperLock Technology = Off
Power Requirements						
Power Supply Sensitivity (MCP4021 and MCP4023 only)	PSS	—	0.0015	0.0035	%/%	$V_{DD} = 4.5\text{V}$ to 5.5V , $V_A = 4.5\text{V}$, Code = 1Fh
		—	0.0015	0.0035	%/%	$V_{DD} = 2.7\text{V}$ to 4.5V , $V_A = 2.7\text{V}$, Code = 1Fh

- Note** 1: Resistance is defined as the resistance between terminal A to terminal B.
 2: INL and DNL are measured at V_W with $V_A = V_{DD}$ and $V_B = V_{SS}$. (-202 devices $V_A = 4\text{V}$).
 3: MCP4021/23 only, test conditions are: $I_W = 1.9\text{mA}$, code = 00h.
 4: MCP4022/24 only, test conditions are:

Device Resistance	Current at Voltage		Comments
	5.5V	2.7V	
2.1 k Ω	2.25 mA	1.1 mA	MCP4022 includes V_{WZSE} MCP4024 includes V_{WFSE}
5 k Ω	1.4 mA	450 μA	
10 k Ω	450 μA	210 μA	
50 k Ω	90 μA	40 μA	

- 5: Resistor terminals A, W and B's polarity with respect to each other is not restricted.
 6: This specification by design
 7: Non-linearity is affected by wiper resistance (R_W), which changes significantly over voltage and temperature. See Section 6.0 "Resistor" for additional information.
 8: The MCP4021 is externally connected to match the configurations of the MCP4022 and MCP4024, and then tested.

MCP4021/2/3/4

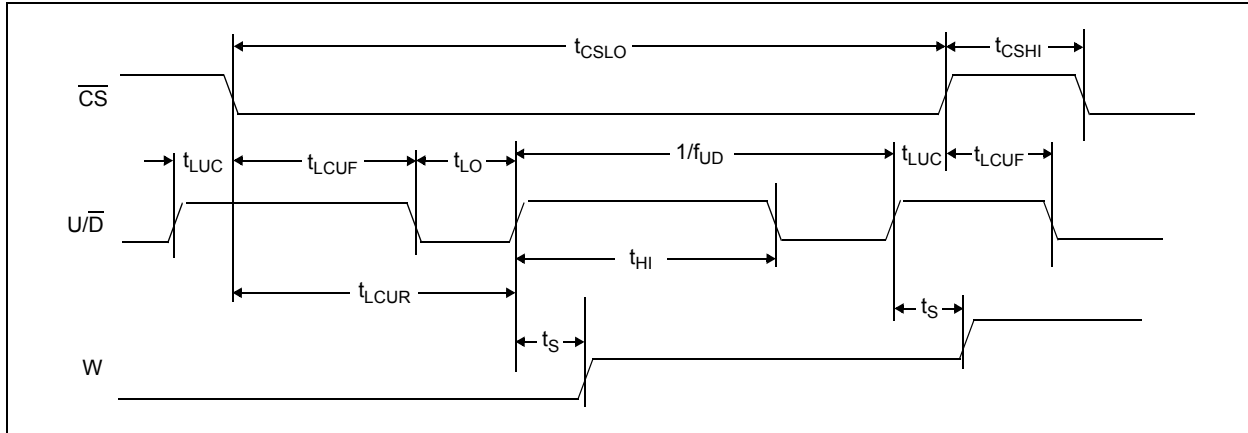

FIGURE 1-1: Increment Timing Waveform.

SERIAL TIMING CHARACTERISTICS

Electrical Specifications: Unless otherwise noted, all parameters apply across the specified operating ranges. Extended (E): $V_{DD} = +2.7V$ to $5.5V$, $T_A = -40^{\circ}C$ to $+125^{\circ}C$.

Parameters	Sym	Min	Typ	Max	Units	Conditions
\overline{CS} Low Time	t_{CSLO}	5	—	—	μs	
\overline{CS} High Time	t_{CSHI}	500	—	—	ns	
U/\overline{D} to \overline{CS} Hold Time	t_{LUC}	500	—	—	ns	
\overline{CS} to U/\overline{D} Low Setup Time	t_{LCUF}	500	—	—	ns	
\overline{CS} to U/\overline{D} High Setup Time	t_{LCUR}	3	—	—	μs	
U/\overline{D} High Time	t_{HI}	500	—	—	ns	
U/\overline{D} Low Time	t_{LO}	500	—	—	ns	
Up/Down Toggle Frequency	f_{UD}	—	—	1	MHz	
Wiper Settling Time	t_S	0.5	—	—	μs	$2.1\text{ k}\Omega$, $C_L = 100\text{ pF}$
		1	—	—	μs	$5\text{ k}\Omega$, $C_L = 100\text{ pF}$
		2	—	—	μs	$10\text{ k}\Omega$, $C_L = 100\text{ pF}$
		10	5	—	μs	$50\text{ k}\Omega$, $C_L = 100\text{ pF}$
Wiper Response on Power-up	t_{PU}	—	200	—	ns	
Internal EEPROM Write Time	t_{WC}	—	—	5	ms	@ $25^{\circ}C$
		—	—	10	ms	$-40^{\circ}C$ to $+125^{\circ}C$

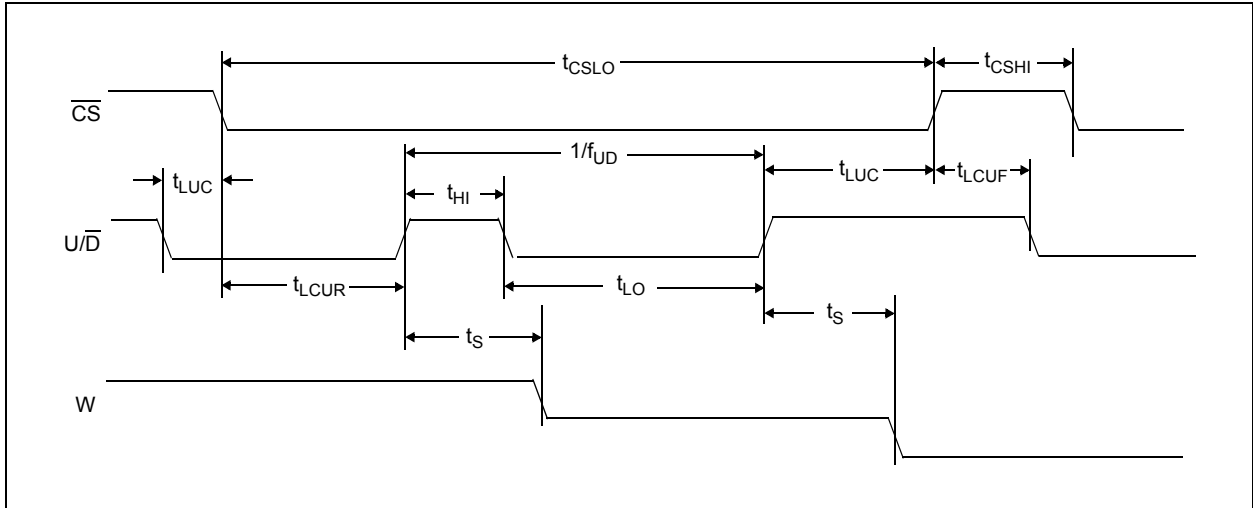

FIGURE 1-2: Decrement Timing Waveform.

SERIAL TIMING CHARACTERISTICS

Electrical Specifications: Unless otherwise noted, all parameters apply across the specified operating ranges. Extended (E): $V_{DD} = +2.7V$ to $5.5V$, $T_A = -40^\circ C$ to $+125^\circ C$.

Parameters	Sym	Min	Typ	Max	Units	Conditions
\overline{CS} Low Time	t_{CSLO}	5	—	—	μs	
\overline{CS} High Time	t_{CSHI}	500	—	—	ns	
U/\overline{D} to \overline{CS} Hold Time	t_{LUC}	500	—	—	ns	
\overline{CS} to U/\overline{D} Low Setup Time	t_{LCUF}	500	—	—	ns	
\overline{CS} to U/\overline{D} High Setup Time	t_{LCUR}	3	—	—	μs	
U/\overline{D} High Time	t_{HI}	500	—	—	ns	
U/\overline{D} Low Time	t_{LO}	500	—	—	ns	
Up/ \overline{Down} Toggle Frequency	f_{UD}	—	—	1	MHz	
Wiper Settling Time	t_S	0.5	—	—	μs	$2.1\ k\Omega$, $C_L = 100\ pF$
		1	—	—	μs	$5\ k\Omega$, $C_L = 100\ pF$
		2	—	—	μs	$10\ k\Omega$, $C_L = 100\ pF$
		10	5	—	μs	$50\ k\Omega$, $C_L = 100\ pF$
Wiper Response on Power-up	t_{PU}	—	200	—	ns	
Internal EEPROM Write Time	t_{wc}	—	—	5	ms	@ $25^\circ C$
		—	—	10	ms	$-40^\circ C$ to $+125^\circ C$

MCP4021/2/3/4

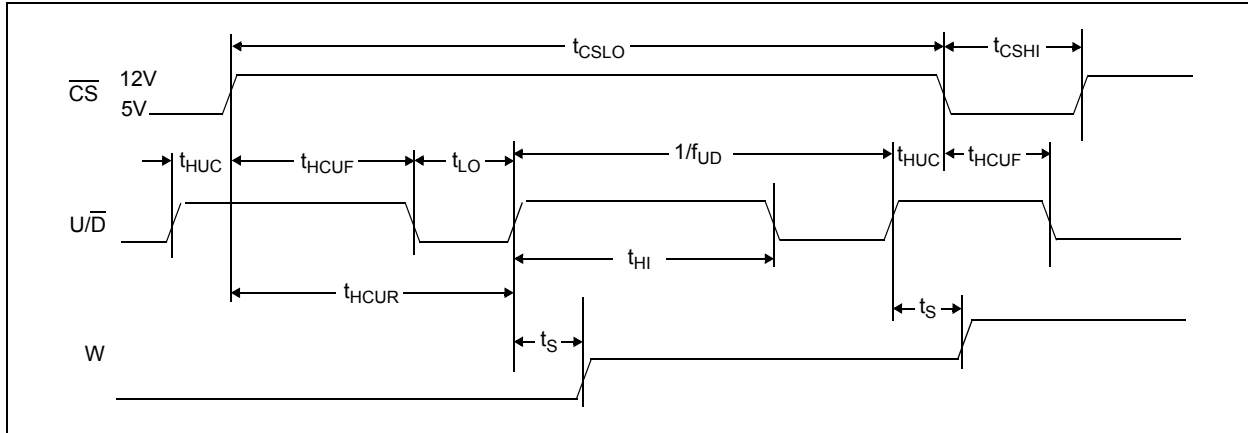

FIGURE 1-3: High-Voltage Increment Timing Waveform.

SERIAL TIMING CHARACTERISTICS

Electrical Specifications: Unless otherwise noted, all parameters apply across the specified operating ranges. Extended (E): $V_{DD} = +2.7V$ to $5.5V$, $T_A = -40^\circ C$ to $+125^\circ C$.

Parameters	Sym	Min	Typ	Max	Units	Conditions
\overline{CS} Low Time	t_{CSLO}	5	—	—	μs	
\overline{CS} High Time	t_{CSHI}	500	—	—	ns	
U/\overline{D} High Time	t_{HI}	500	—	—	ns	
U/\overline{D} Low Time	t_{LO}	500	—	—	ns	
Up/Down Toggle Frequency	f_{UD}	—	—	1	MHz	
HV U/\overline{D} to \overline{CS} Hold Time	t_{HUC}	1.5	—	—	μs	
HV \overline{CS} to U/\overline{D} Low Setup Time	t_{HUCUF}	8	—	—	μs	
HV \overline{CS} to U/\overline{D} High Setup Time	t_{HUCUR}	4.5	—	—	μs	
Wiper Settling Time	t_S	0.5	—	—	μs	$2.1\text{ k}\Omega$, $C_L = 100\text{ pF}$
		1	—	—	μs	$5\text{ k}\Omega$, $C_L = 100\text{ pF}$
		2	—	—	μs	$10\text{ k}\Omega$, $C_L = 100\text{ pF}$
		10	5	—	μs	$50\text{ k}\Omega$, $C_L = 100\text{ pF}$
Wiper Response on Power-up	t_{PU}	—	200	—	ns	
Internal EEPROM Write Time	t_{WC}	—	—	5	ms	@ $25^\circ C$
		—	—	10	ms	$-40^\circ C$ to $+125^\circ C$

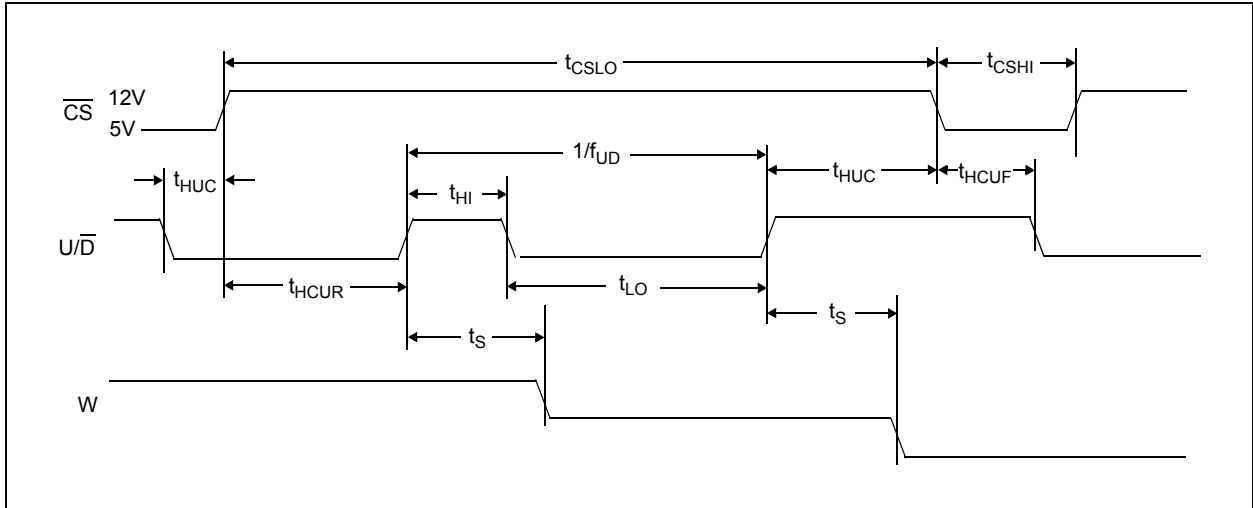

FIGURE 1-4: High-Voltage Decrement Timing Waveform.

SERIAL TIMING CHARACTERISTICS

Electrical Specifications: Unless otherwise noted, all parameters apply across the specified operating ranges. Extended (E): $V_{DD} = +2.7V$ to $5.5V$, $T_A = -40^\circ C$ to $+125^\circ C$.

Parameters	Sym	Min	Typ	Max	Units	Conditions
\overline{CS} Low Time	t_{CSLO}	5	—	—	μs	
\overline{CS} High Time	t_{CSHI}	500	—	—	ns	
U/\overline{D} High Time	t_{HI}	500	—	—	ns	
U/\overline{D} Low Time	t_{LO}	500	—	—	ns	
Up/Down Toggle Frequency	f_{UD}	—	—	1	MHz	
HV U/\overline{D} to \overline{CS} Hold Time	t_{HUC}	1.5	—	—	μs	
HV \overline{CS} to U/\overline{D} Low Setup Time	t_{HCUF}	8	—	—	μs	
HV \overline{CS} to U/\overline{D} High Setup Time	t_{HCUR}	4.5	—	—	μs	
Wiper Settling Time	t_S	0.5	—	—	μs	$2.1\text{ k}\Omega$, $C_L = 100\text{ pF}$
		1	—	—	μs	$5\text{ k}\Omega$, $C_L = 100\text{ pF}$
		2	—	—	μs	$10\text{ k}\Omega$, $C_L = 100\text{ pF}$
		10	5	—	μs	$50\text{ k}\Omega$, $C_L = 100\text{ pF}$
Wiper Response on Power-up	t_{PU}	—	200	—	ns	
Internal EEPROM Write Time	t_{wc}	—	—	5	ms	@ $25^\circ C$
		—	—	10	ms	$-40^\circ C$ to $+125^\circ C$

MCP4021/2/3/4

TEMPERATURE CHARACTERISTICS

Electrical Specifications: Unless otherwise indicated, $V_{DD} = +2.7V$ to $+5.5V$, $V_{SS} = GND$.						
Parameters	Sym	Min	Typ	Max	Units	Conditions
Temperature Ranges						
Specified Temperature Range	T_A	-40	—	+125	°C	
Operating Temperature Range	T_A	-40	—	+125	°C	
Storage Temperature Range	T_A	-65	—	+150	°C	
Thermal Package Resistances						
Thermal Resistance, 5L-SOT-23	θ_{JA}	—	255	—	°C/W	
Thermal Resistance, 6L-SOT-23	θ_{JA}	—	230	—	°C/W	
Thermal Resistance, 8L-DFN (2x3)	θ_{JA}	—	85	—	°C/W	
Thermal Resistance, 8L-MSOP	θ_{JA}	—	206	—	°C/W	
Thermal Resistance, 8L-SOIC	θ_{JA}	—	117	—	°C/W	

2.0 TYPICAL PERFORMANCE CURVES

Note: The graphs and tables provided following this note are a statistical summary based on a limited number of samples and are provided for informational purposes only. The performance characteristics listed herein are not tested or guaranteed. In some graphs or tables, the data presented may be outside the specified operating range (e.g., outside specified power supply range) and therefore outside the warranted range.

Note: Unless otherwise indicated, $T_A = +25^\circ\text{C}$, $V_{DD} = 5\text{V}$, $V_{SS} = 0\text{V}$.

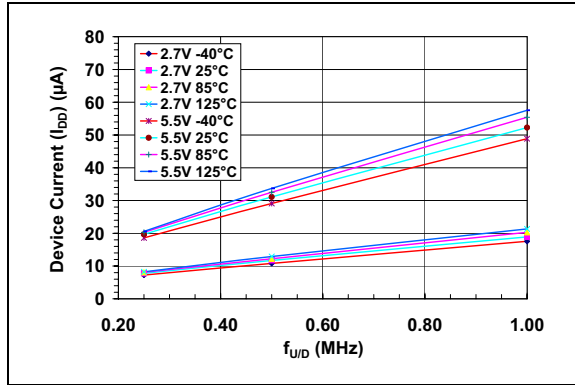

FIGURE 2-1: Device Current (I_{DD}) vs. U/D Frequency (f_{UD}) and Ambient Temperature ($V_{DD} = 2.7\text{V}$ and 5.5V).

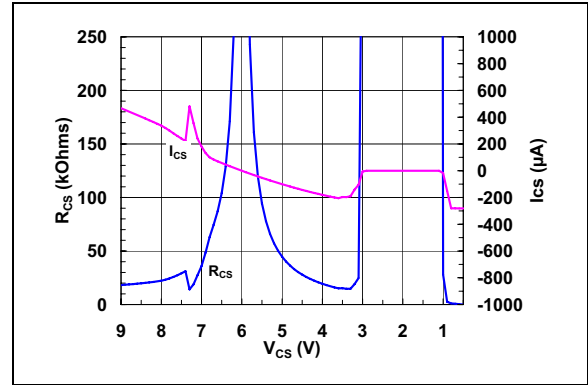

FIGURE 2-4: \overline{CS} Pull-up/Pull-down Resistance (R_{CS}) and Current (I_{CS}) vs. \overline{CS} Input Voltage (V_{CS}) ($V_{DD} = 5.5\text{V}$).

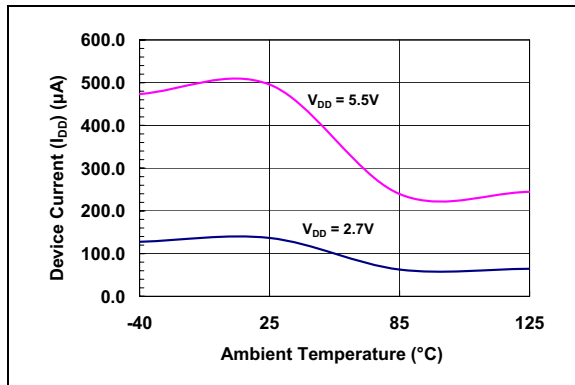

FIGURE 2-2: Write Current (I_{WRITE}) vs. Ambient Temperature and V_{DD} .

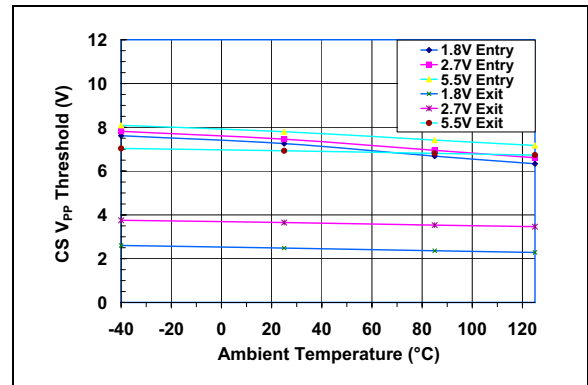

FIGURE 2-5: \overline{CS} High Input Entry/Exit Threshold vs. Ambient Temperature and V_{DD} .

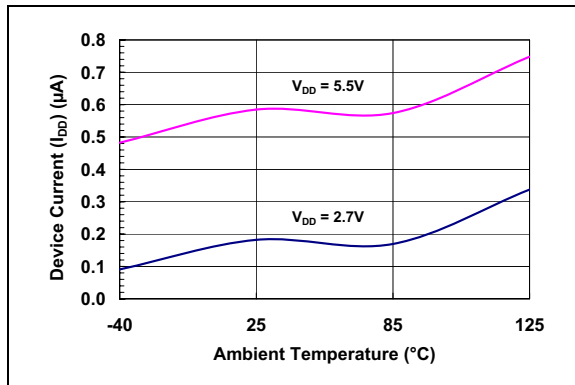

FIGURE 2-3: Device Current (I_{SHDN}) vs. Ambient Temperature and V_{DD} . ($\overline{CS} = V_{DD}$).

MCP4021/2/3/4

Note: Unless otherwise indicated, $T_A = +25^\circ\text{C}$, $V_{DD} = 5\text{V}$, $V_{SS} = 0\text{V}$.

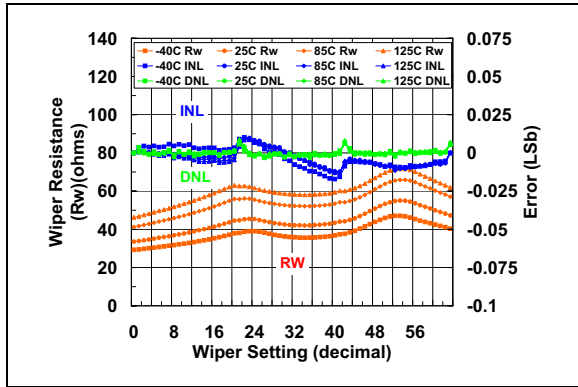

FIGURE 2-6: 2.1 k Ω Pot Mode – R_W (Ω), INL (LSb), DNL (LSb) vs. Wiper Setting and Ambient Temperature ($V_{DD} = 5.5\text{V}$).

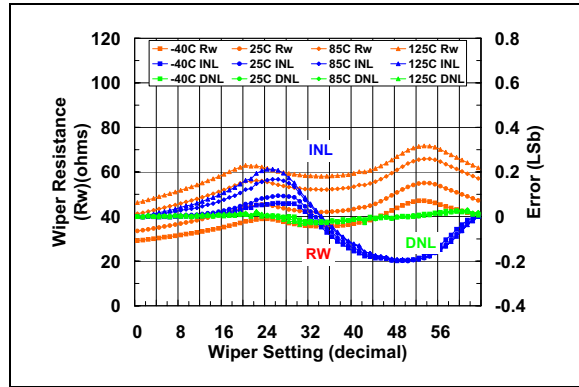

FIGURE 2-8: 2.1 k Ω Rheo Mode – R_W (Ω), INL (LSb), DNL (LSb) vs. Wiper Setting and Ambient Temperature ($V_{DD} = 5.5\text{V}$).

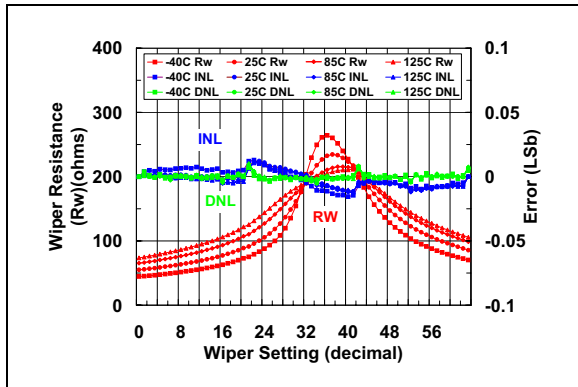

FIGURE 2-7: 2.1 k Ω Pot Mode – R_W (Ω), INL (LSb), DNL (LSb) vs. Wiper Setting and Ambient Temperature ($V_{DD} = 2.7\text{V}$).

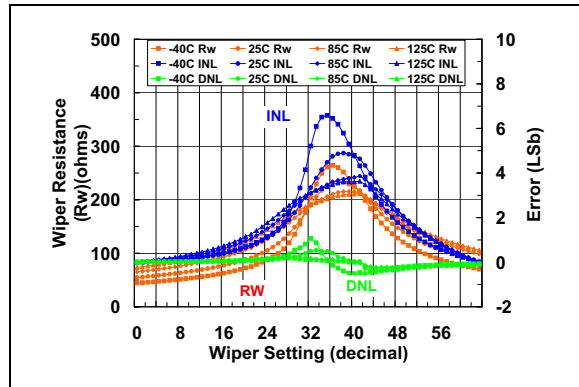

FIGURE 2-9: 2.1 k Ω Rheo Mode – R_W (Ω), INL (LSb), DNL (LSb) vs. Wiper Setting and Ambient Temperature ($V_{DD} = 2.7\text{V}$).

Note: Unless otherwise indicated, $T_A = +25^\circ\text{C}$, $V_{DD} = 5\text{V}$, $V_{SS} = 0\text{V}$.

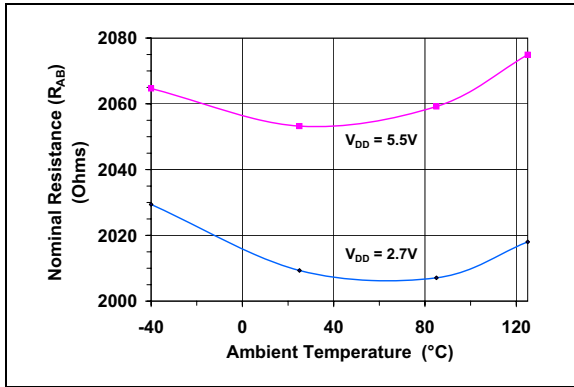

FIGURE 2-10: $2.1\text{ k}\Omega$ – Nominal Resistance (Ω) vs. Ambient Temperature and V_{DD} .

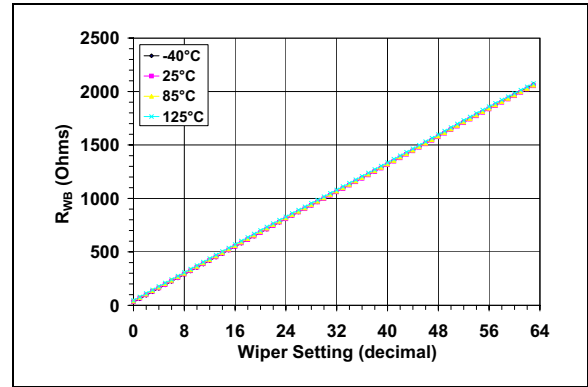

FIGURE 2-11: $2.1\text{ k}\Omega$ – R_{WB} (Ω) vs. Wiper Setting and Ambient Temperature.

MCP4021/2/3/4

Note: Unless otherwise indicated, $T_A = +25^\circ\text{C}$, $V_{DD} = 5\text{V}$, $V_{SS} = 0\text{V}$.

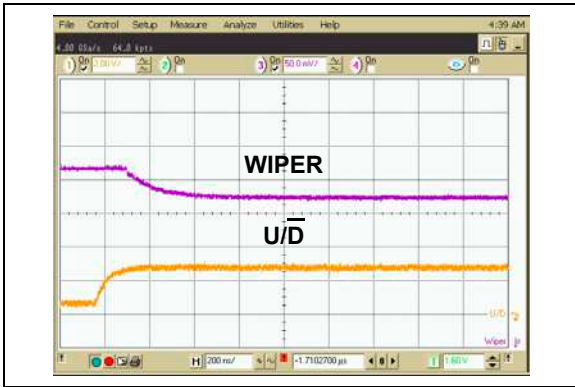

FIGURE 2-12: 2.1 k Ω – Low-Voltage Decrement Wiper Settling Time ($V_{DD} = 2.7\text{V}$).

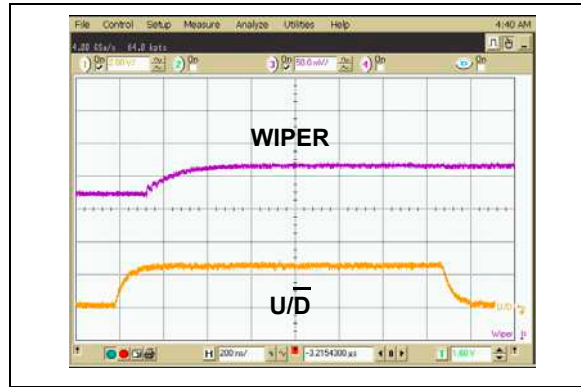

FIGURE 2-15: 2.1 k Ω – Low-Voltage Increment Wiper Settling Time ($V_{DD} = 2.7\text{V}$).

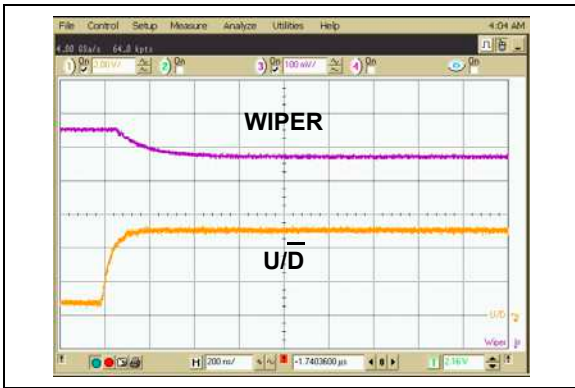

FIGURE 2-13: 2.1 k Ω – Low-Voltage Decrement Wiper Settling Time ($V_{DD} = 5.5\text{V}$).

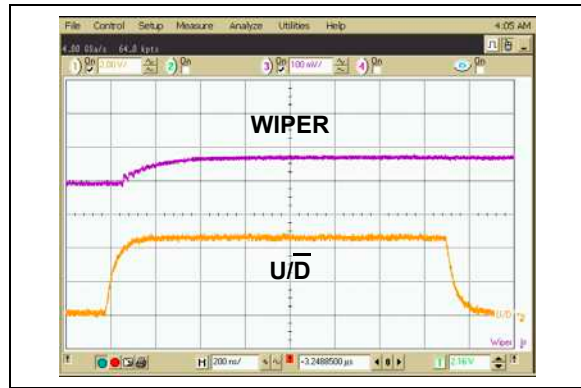

FIGURE 2-16: 2.1 k Ω – Low-Voltage Increment Wiper Settling Time ($V_{DD} = 5.5\text{V}$).



FIGURE 2-14: 2.1 k Ω – Power-Up Wiper Response Time.

Note: Unless otherwise indicated, $T_A = +25^\circ\text{C}$, $V_{DD} = 5\text{V}$, $V_{SS} = 0\text{V}$.

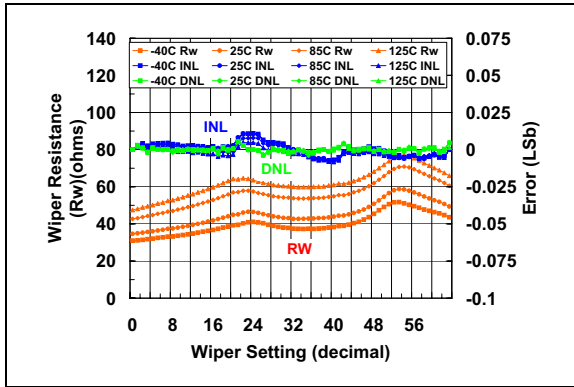

FIGURE 2-17: 5 k Ω Pot Mode – R_W (Ω), INL (LSb), DNL (LSb) vs. Wiper Setting and Ambient Temperature ($V_{DD} = 5.5\text{V}$).

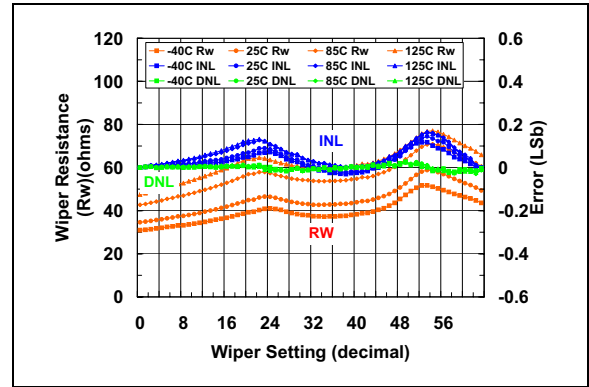

FIGURE 2-19: 5 k Ω Rheo Mode – R_W (Ω), INL (LSb), DNL (LSb) vs. Wiper Setting and Ambient Temperature ($V_{DD} = 5.5\text{V}$).

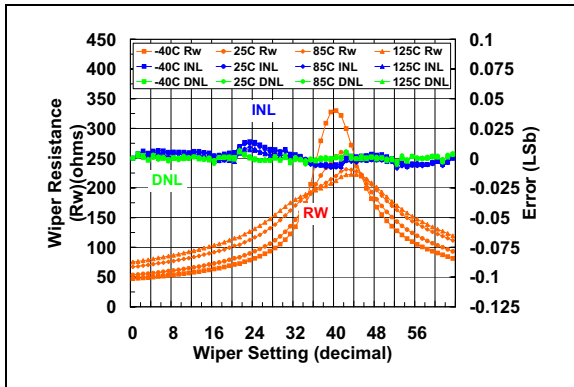

FIGURE 2-18: 5 k Ω Pot Mode – R_W (Ω), INL (LSb), DNL (LSb) vs. Wiper Setting and Ambient Temperature ($V_{DD} = 2.7\text{V}$).

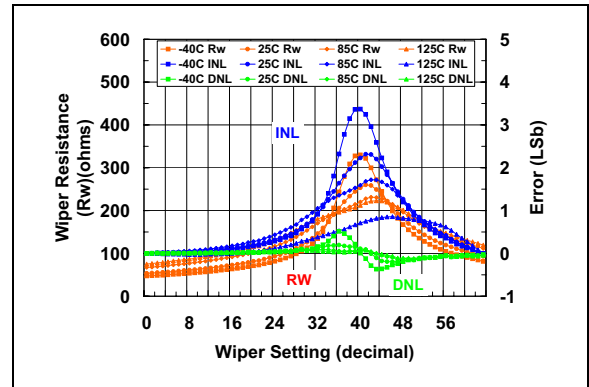

FIGURE 2-20: 5 k Ω Rheo Mode – R_W (Ω), INL (LSb), DNL (LSb) vs. Wiper Setting and Ambient Temperature ($V_{DD} = 2.7\text{V}$).

MCP4021/2/3/4

Note: Unless otherwise indicated, $T_A = +25^\circ\text{C}$, $V_{DD} = 5\text{V}$, $V_{SS} = 0\text{V}$.

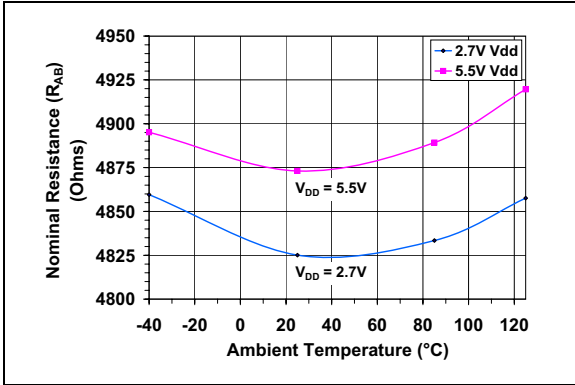

FIGURE 2-21: $5\text{ k}\Omega$ – Nominal Resistance (Ω) vs. Ambient Temperature and V_{DD} .

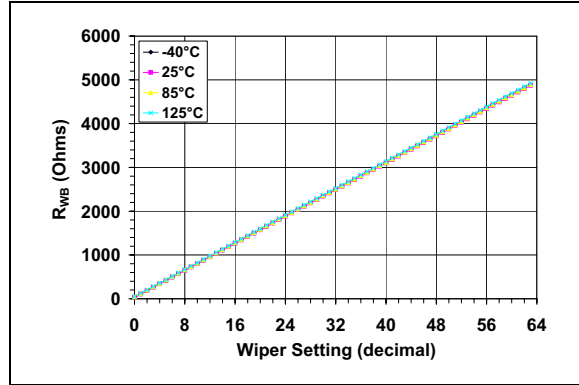

FIGURE 2-22: $5\text{ k}\Omega$ – R_{WB} (Ω) vs. Wiper Setting and Ambient Temperature.

Note: Unless otherwise indicated, $T_A = +25^\circ\text{C}$, $V_{DD} = 5\text{V}$, $V_{SS} = 0\text{V}$.

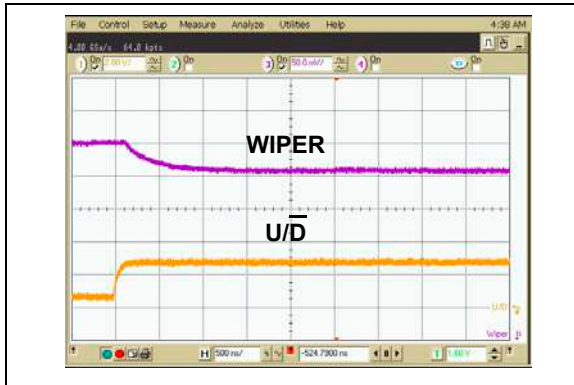

FIGURE 2-23: $5\text{ k}\Omega$ – Low-Voltage Decrement Wiper Settling Time ($V_{DD} = 2.7\text{V}$).

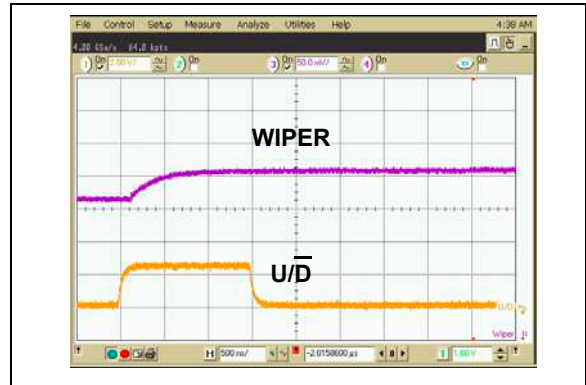

FIGURE 2-25: $5\text{ k}\Omega$ – Low-Voltage Increment Wiper Settling Time ($V_{DD} = 2.7\text{V}$).

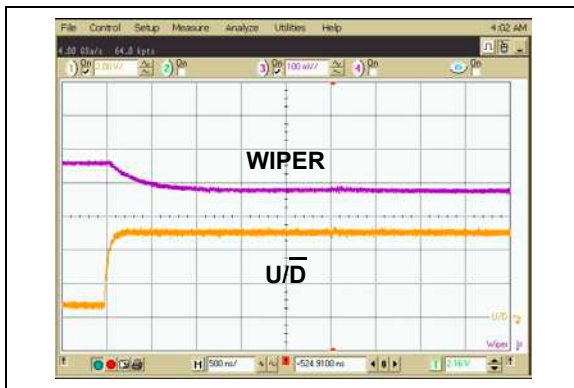

FIGURE 2-24: $5\text{ k}\Omega$ – Low-Voltage Decrement Wiper Settling Time ($V_{DD} = 5.5\text{V}$).

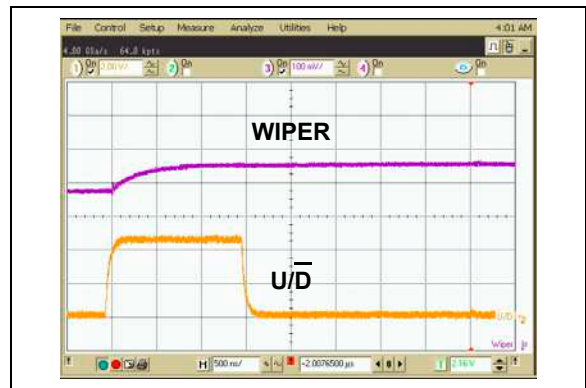

FIGURE 2-26: $5\text{ k}\Omega$ – Low-Voltage Increment Wiper Settling Time ($V_{DD} = 5.5\text{V}$).

MCP4021/2/3/4

Note: Unless otherwise indicated, $T_A = +25^\circ\text{C}$, $V_{DD} = 5\text{V}$, $V_{SS} = 0\text{V}$.

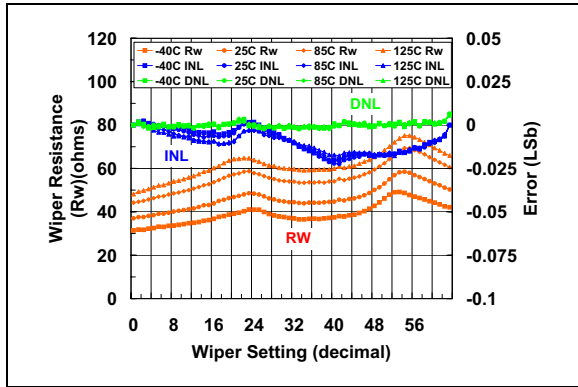

FIGURE 2-27: 10 k Ω Pot Mode – R_W (Ω), INL (LSb), DNL (LSb) vs. Wiper Setting and Ambient Temperature ($V_{DD} = 5.5\text{V}$).

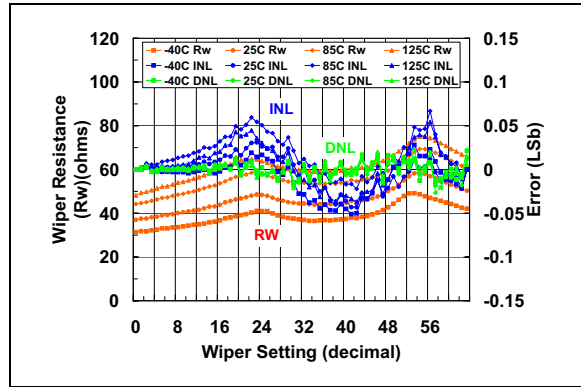

FIGURE 2-29: 10 k Ω Rheo Mode – R_W (Ω), INL (LSb), DNL (LSb) vs. Wiper Setting and Ambient Temperature ($V_{DD} = 5.5\text{V}$).

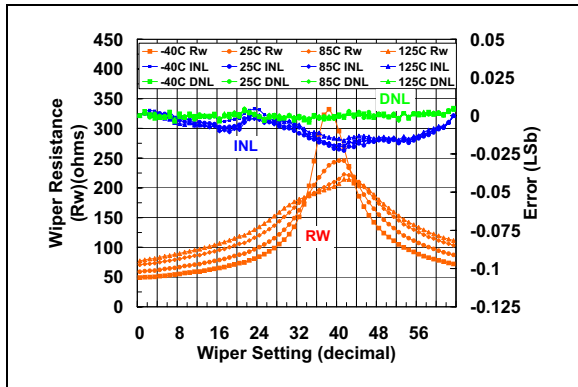

FIGURE 2-28: 10 k Ω Pot Mode – R_W (Ω), INL (LSb), DNL (LSb) vs. Wiper Setting and Ambient Temperature ($V_{DD} = 2.7\text{V}$).

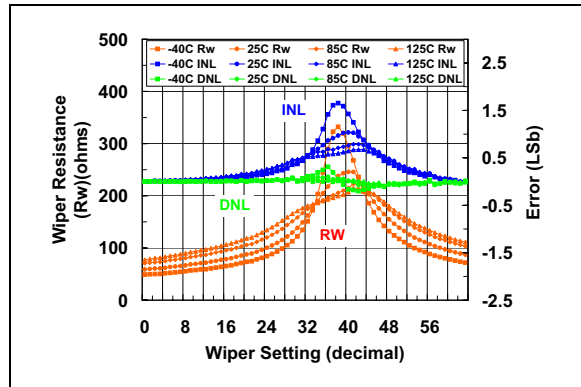

FIGURE 2-30: 10 k Ω Rheo Mode – R_W (Ω), INL (LSb), DNL (LSb) vs. Wiper Setting and Ambient Temperature ($V_{DD} = 2.7\text{V}$).

Note: Unless otherwise indicated, $T_A = +25^\circ\text{C}$, $V_{DD} = 5\text{V}$, $V_{SS} = 0\text{V}$.

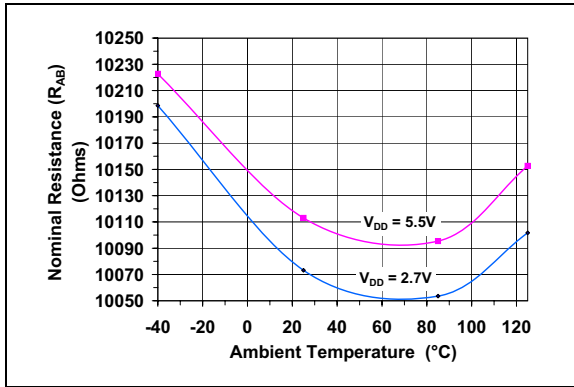

FIGURE 2-31: $10\text{ k}\Omega$ —Nominal Resistance (Ω) vs. Ambient Temperature and V_{DD} .

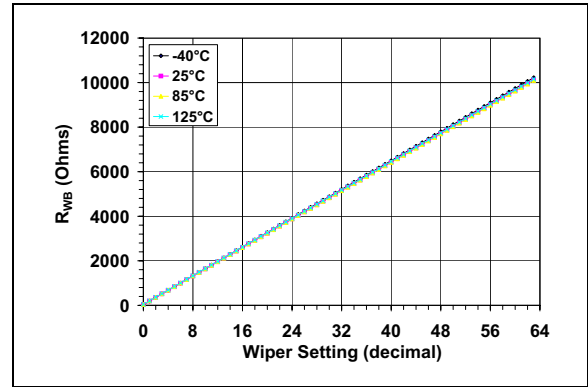

FIGURE 2-32: $10\text{ k}\Omega$ — R_{WB} (Ω) vs. Wiper Setting and Ambient Temperature.

MCP4021/2/3/4

Note: Unless otherwise indicated, $T_A = +25^\circ\text{C}$, $V_{DD} = 5\text{V}$, $V_{SS} = 0\text{V}$.

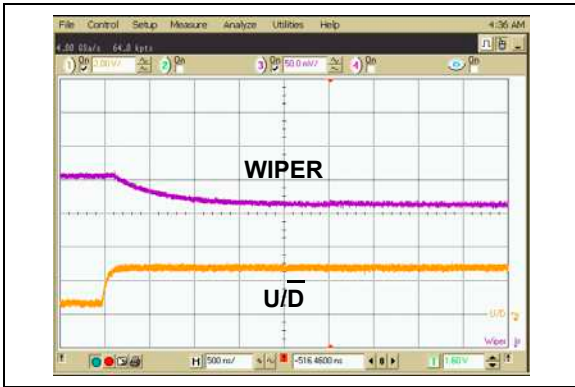

FIGURE 2-33: $10\text{ k}\Omega$ – Low-Voltage Decrement Wiper Settling Time ($V_{DD} = 2.7\text{V}$).

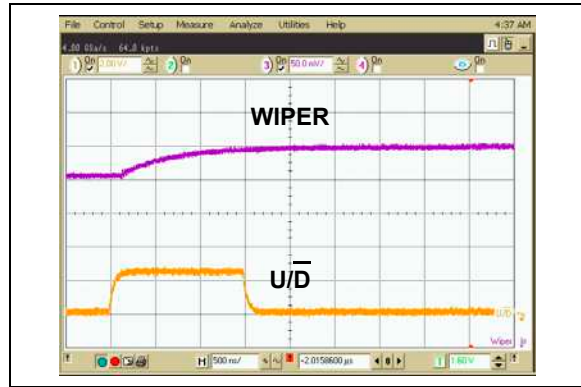

FIGURE 2-35: $10\text{ k}\Omega$ – Low-Voltage Increment Wiper Settling Time ($V_{DD} = 2.7\text{V}$).

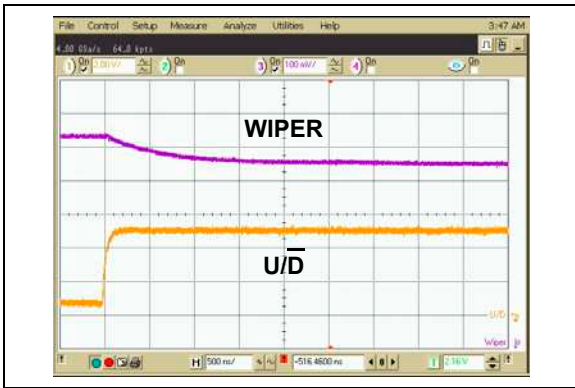

FIGURE 2-34: $10\text{ k}\Omega$ – Low-Voltage Decrement Wiper Settling Time ($V_{DD} = 5.5\text{V}$).

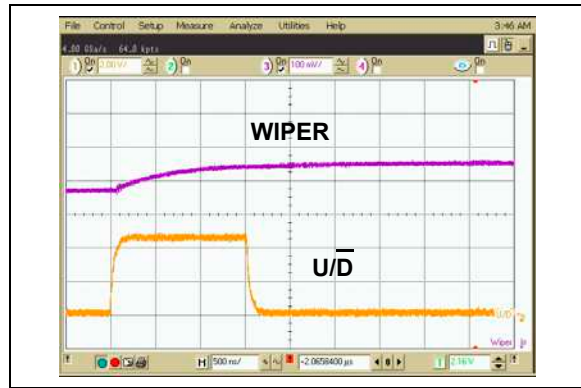

FIGURE 2-36: $10\text{ k}\Omega$ – Low-Voltage Increment Wiper Settling Time ($V_{DD} = 5.5\text{V}$).

Note: Unless otherwise indicated, $T_A = +25^\circ\text{C}$, $V_{DD} = 5\text{V}$, $V_{SS} = 0\text{V}$.

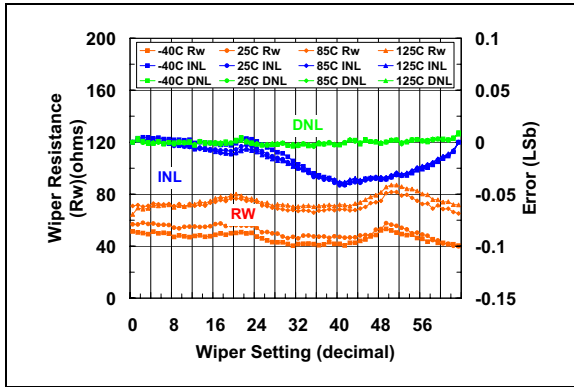

FIGURE 2-37: 50 k Ω Pot Mode – R_W (Ω), INL (LSb), DNL (LSb) vs. Wiper Setting and Ambient Temperature ($V_{DD} = 5.5\text{V}$).

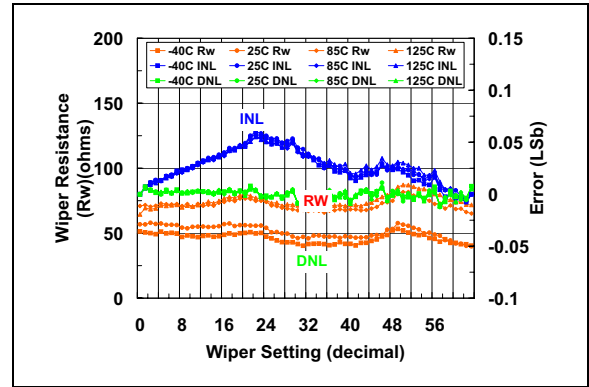

FIGURE 2-39: 50 k Ω Rheo Mode – R_W (Ω), INL (LSb), DNL (LSb) vs. Wiper Setting and Ambient Temperature ($V_{DD} = 5.5\text{V}$).

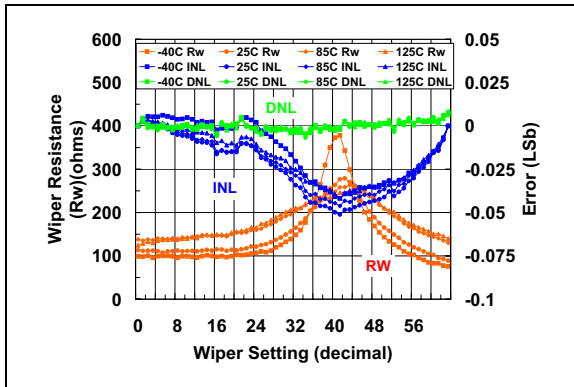

FIGURE 2-38: 50 k Ω Pot Mode – R_W (Ω), INL (LSb), DNL (LSb) vs. Wiper Setting and Ambient Temperature ($V_{DD} = 2.7\text{V}$).

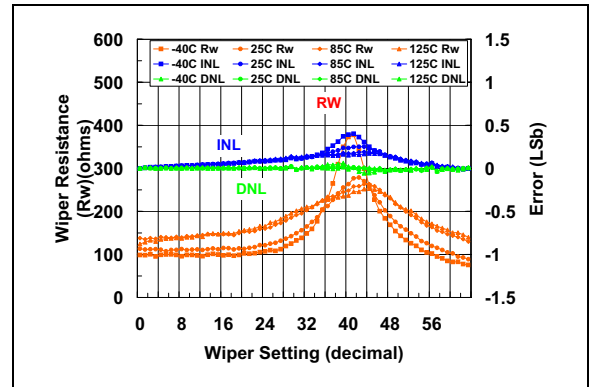

FIGURE 2-40: 50 k Ω Rheo Mode – R_W (Ω), INL (LSb), DNL (LSb) vs. Wiper Setting and Ambient Temperature ($V_{DD} = 2.7\text{V}$).

MCP4021/2/3/4

Note: Unless otherwise indicated, $T_A = +25^\circ\text{C}$, $V_{DD} = 5\text{V}$, $V_{SS} = 0\text{V}$.

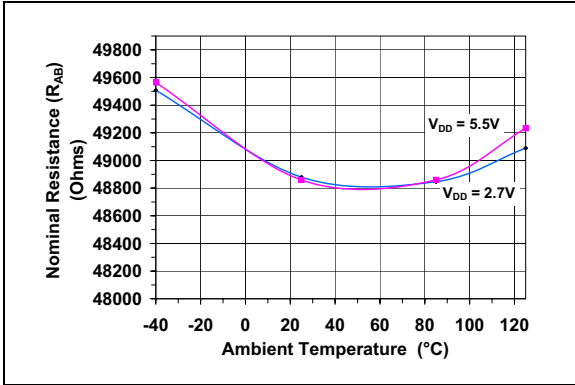

FIGURE 2-41: $50\text{ k}\Omega$ —Nominal Resistance (Ω) vs. Ambient Temperature and V_{DD} .

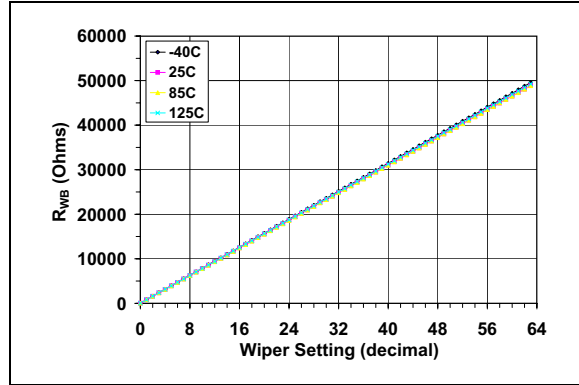

FIGURE 2-42: $50\text{ k}\Omega$ — R_{WB} (Ω) vs. Wiper Setting and Ambient Temperature.

Note: Unless otherwise indicated, $T_A = +25^\circ\text{C}$, $V_{DD} = 5\text{V}$, $V_{SS} = 0\text{V}$.

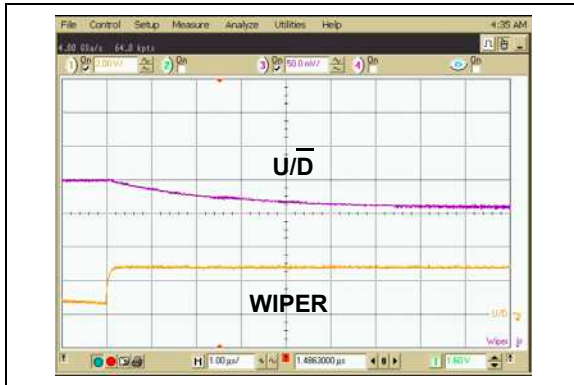

FIGURE 2-43: 50 kΩ – Low-Voltage Decrement Wiper Settling Time ($V_{DD} = 2.7\text{V}$).

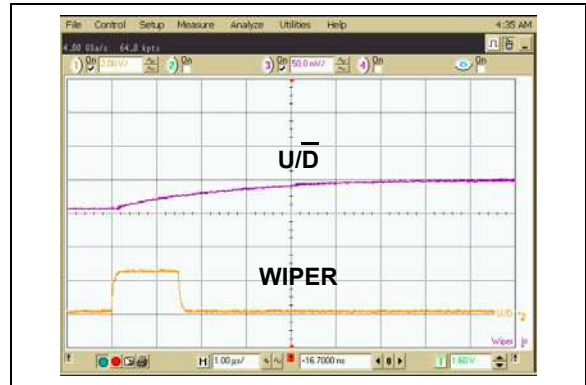

FIGURE 2-46: 50 kΩ – Low-Voltage Increment Wiper Settling Time ($V_{DD} = 2.7\text{V}$).

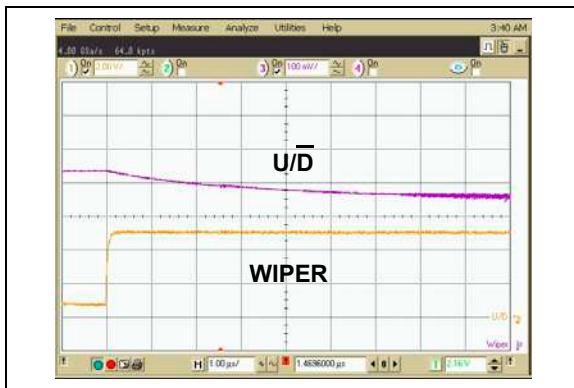

FIGURE 2-44: 50 kΩ – Low-Voltage Decrement Wiper Settling Time ($V_{DD} = 5.5\text{V}$).

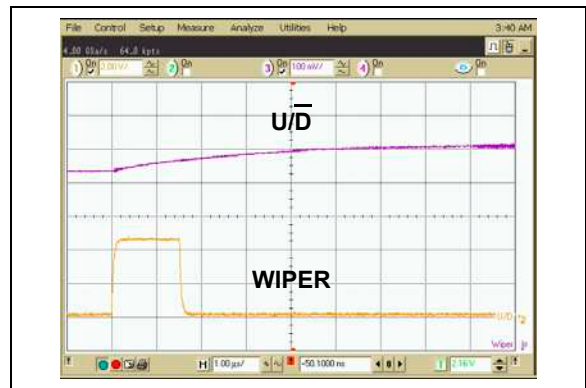

FIGURE 2-47: 50 kΩ – Low-Voltage Increment Wiper Settling Time ($V_{DD} = 5.5\text{V}$).



FIGURE 2-45: 50 kΩ – Power-Up Wiper Response Time.

MCP4021/2/3/4

Note: Unless otherwise indicated, $T_A = +25^\circ\text{C}$, $V_{DD} = 5\text{V}$, $V_{SS} = 0\text{V}$.

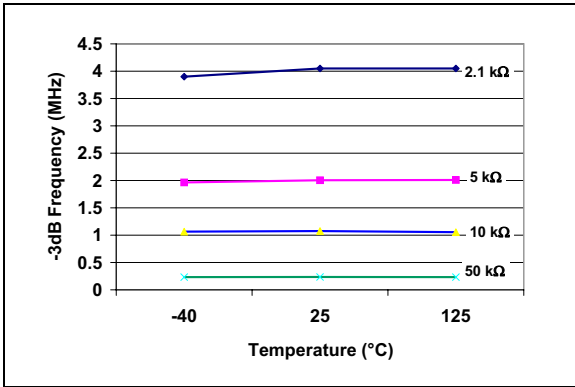

FIGURE 2-48: -3 dB Bandwidth vs. Temperature.

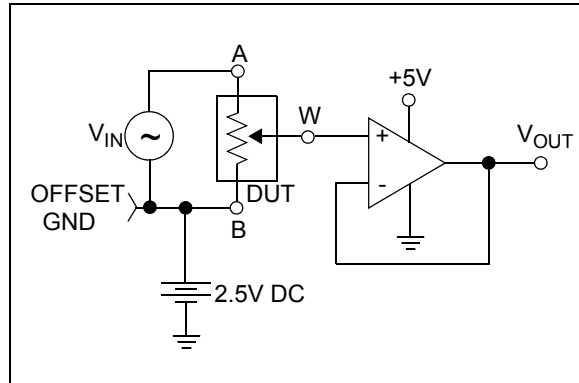

FIGURE 2-49: -3 dB Bandwidth Test Circuit.

3.0 PIN DESCRIPTIONS

The descriptions of the pins are listed in [Table 3-1](#).

TABLE 3-1: PIN FUNCTION TABLE

Pin Number			Symbol	Pin Type	Buffer Type	Function
MCP4021 (SOIC-8)	MCP4022 MCP4023 (SOT-23-6)	MCP4024 (SOT-23-5)				
1	1	1	V_{DD}	P	—	Positive Power Supply Input
2	2	2	V_{SS}	P	—	Ground
3	6	—	A	I/O	A	Potentiometer Terminal A
4	5	5	W	I/O	A	Potentiometer Wiper Terminal
5	4	4	\overline{CS}	I	TTL	Chip Select Input
6	—	—	B	I/O	A	Potentiometer Terminal B
7	—	—	NC	—	—	No Connection
8	3	3	U/\overline{D}	I	TTL	Increment/Decrement Input

Legend: TTL = TTL compatible input A = Analog input
 I = Input O = Output
 P = Power

3.1 Positive Power Supply Input (V_{DD})

The V_{DD} pin is the device's positive power supply input. The input power supply is relative to V_{SS} and can range from 2.7V to 5.5V. A decoupling capacitor on V_{DD} (to V_{SS}) is recommended to achieve maximum performance.

3.2 Ground (V_{SS})

The V_{SS} pin is the device ground reference.

3.3 Potentiometer Terminal A

The terminal A pin is connected to the internal potentiometer's terminal A (available on some devices). The potentiometer's terminal A is the fixed connection to the 0x3F terminal of the digital potentiometer.

The terminal A pin is available on the MCP4021, MCP4022 and MCP4023 devices. The terminal A pin does not have a polarity relative to the terminal W or B pins. The terminal A pin can support both positive and negative current. The voltage on terminal A must be between V_{SS} and V_{DD} .

The terminal A pin is not available on the MCP4024. The potentiometer's terminal A is internally floating.

3.4 Potentiometer Wiper (W) Terminal

The terminal W pin is connected to the internal potentiometer's terminal W (the wiper). The wiper terminal is the adjustable terminal of the digital potentiometer. The terminal W pin does not have a polarity relative to terminals A or B pins. The terminal W pin can support both positive and negative current. The voltage on terminal W must be between V_{SS} and V_{DD} .

3.5 Potentiometer Terminal B

The terminal B pin is connected to the internal potentiometer's terminal B (available on some devices). The potentiometer's terminal B is the fixed connection to the 0x00 terminal of the digital potentiometer.

The terminal B pin is available on the MCP4021 device. The terminal B pin does not have a polarity relative to the terminal W or A pins. The terminal B pin can support both positive and negative current. The voltage on terminal B must be between V_{SS} and V_{DD} .

The terminal B pin is not available on the MCP4022, MCP4023 and MCP4024 devices.

For the MCP4023 and MCP4024, the internal potentiometer's terminal B is internally connected to V_{SS} . Terminal B does not have a polarity relative to terminals W or A. Terminal B can support both positive and negative current.

For the MCP4022, terminal B is internally floating.