



Chipsmall Limited consists of a professional team with an average of over 10 year of expertise in the distribution of electronic components. Based in Hongkong, we have already established firm and mutual-benefit business relationships with customers from,Europe,America and south Asia,supplying obsolete and hard-to-find components to meet their specific needs.

With the principle of “Quality Parts,Customers Priority,Honest Operation,and Considerate Service”,our business mainly focus on the distribution of electronic components. Line cards we deal with include Microchip,ALPS,ROHM,Xilinx,Pulse,ON,Everlight and Freescale. Main products comprise IC,Modules,Potentiometer,IC Socket,Relay,Connector.Our parts cover such applications as commercial,industrial, and automotives areas.

We are looking forward to setting up business relationship with you and hope to provide you with the best service and solution. Let us make a better world for our industry!



## Contact us

Tel: +86-755-8981 8866 Fax: +86-755-8427 6832

Email & Skype: info@chipsmall.com Web: www.chipsmall.com

Address: A1208, Overseas Decoration Building, #122 Zhenhua RD., Futian, Shenzhen, China



## 450 nA, 9 kHz Op Amp

### Features:

- Low Quiescent Current: 450 nA (typical)
- Gain Bandwidth Product: 9 kHz (typical)
- Supply Voltage Range: 1.4V to 6.0V
- Rail-to-Rail Input and Output
- Unity Gain Stable
- Slew Rate: 3V/ms (typical)
- Extended Temperature Range: -40°C to +125°C
- No Phase Reversal
- Small Packages

### Applications:

- Portable Equipment
- Battery Powered System
- Data Acquisition Equipment
- Sensor Conditioning
- Battery Current Sensing
- Analog Active Filters

### Design Aids:

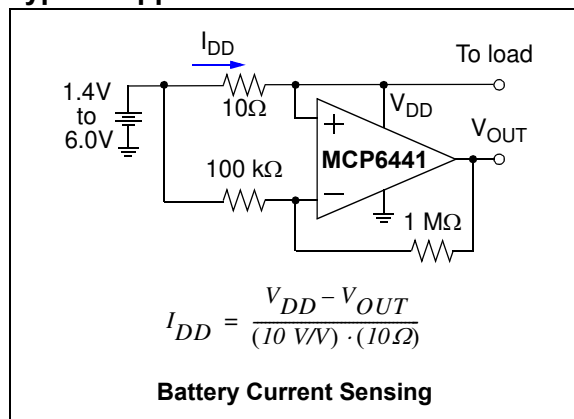
- SPICE Macro Models
- FilterLab<sup>®</sup> Software
- Microchip Advanced Part Selector (MAPS)
- Analog Demonstration and Evaluation Boards
- Application Notes

### Description:

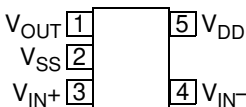
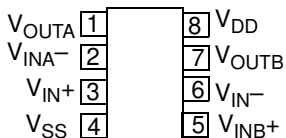
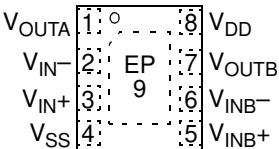
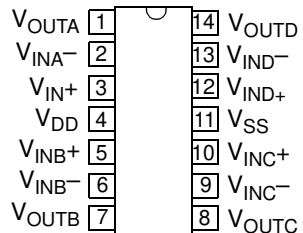
The MCP6441/2/4 device is a single nanopower operational amplifier (op amp), which has low quiescent current (450 nA, typical) and rail-to-rail input and output operation. This op amp is unity gain stable and has a gain bandwidth product of 9 kHz (typical). These devices operate with a single supply voltage as low as 1.4V. These features make the family of op amps well suited for single-supply, battery-powered applications.

The MCP6441/2/4 op amp is designed with Microchip's advanced CMOS process and offered in single (MCP6441), dual (MCP6442), and quad (MCP6444) configurations. All devices are available in the extended temperature range, with a power supply range of 1.4V to 6.0V.

### Typical Application



### Package Types

MCP6441 SC70-5, SOT-23-5	MCP6442 SOIC, MSOP	MCP6442 2x3 TDFN *	MCP6444 SOIC, TSSOP
			
* Includes Exposed Thermal Pad (EP); see <a href="#">Table 3-1</a> .			

# MCP6441/2/4

---

NOTES:

## 1.0 ELECTRICAL CHARACTERISTICS

### 1.1 Absolute Maximum Ratings †

$V_{DD} - V_{SS}$ .....	7.0V
Current at Input Pins .....	$\pm 2$ mA
Analog Inputs ( $V_{IN+}$ , $V_{IN-}$ )†† .....	$V_{SS} - 1.0V$ to $V_{DD} + 1.0V$
All Other Inputs and Outputs .....	$V_{SS} - 0.3V$ to $V_{DD} + 0.3V$
Difference Input Voltage .....	$ V_{DD} - V_{SS} $
Output Short-Circuit Current .....	Continuous
Current at Output and Supply Pins .....	$\pm 30$ mA
Storage Temperature .....	$-65^{\circ}C$ to $+150^{\circ}C$
Maximum Junction Temperature ( $T_J$ ) .....	$+150^{\circ}C$
ESD Protection on All Pins (HBM; MM) .....	$\geq 4$ kV; 200V

† **Notice:** Stresses above those listed under “Absolute Maximum Ratings” may cause permanent damage to the device. This is a stress rating only and functional operation of the device at those or any other conditions above those indicated in the operational listings of this specification is not implied. Exposure to maximum rating conditions for extended periods may affect device reliability.

†† See [Section 4.1.2 “Input Voltage Limits”](#).

## DC ELECTRICAL SPECIFICATIONS

**Electrical Characteristics:** Unless otherwise indicated,  $V_{DD} = +1.4V$  to  $+6.0V$ ,  $V_{SS} = GND$ ,  $T_A = +25^{\circ}C$ ,  $V_{CM} = V_{DD}/2$ ,  $V_{OUT} \approx V_{DD}/2$ ,  $V_L = V_{DD}/2$  and  $R_L = 1 M\Omega$  to  $V_L$ . (Refer to [Figure 1-1](#)).

Parameters	Sym	Min	Typ	Max	Units	Conditions
<b>Input Offset</b>						
Input Offset Voltage	$V_{OS}$	-4.5	—	+4.5	mV	$V_{CM} = V_{SS}$
Input Offset Drift with Temperature	$\Delta V_{OS}/\Delta T_A$	—	$\pm 2.5$	—	$\mu V/^{\circ}C$	$T_A = -40^{\circ}C$ to $+125^{\circ}C$ , $V_{CM} = V_{SS}$
Power Supply Rejection Ratio	PSRR	65	86	—	dB	$V_{CM} = V_{SS}$
<b>Input Bias Current and Impedance</b>						
Input Bias Current	$I_B$	—	$\pm 1$	—	pA	
		—	20	—	pA	$T_A = +85^{\circ}C$
		—	400	—	pA	$T_A = +125^{\circ}C$
Input Offset Current	$I_{OS}$	—	$\pm 1$	—	pA	
Common Mode Input Impedance	$Z_{CM}$	—	$10^{13}    6$	—	$\Omega    pF$	
Differential Input Impedance	$Z_{DIFF}$	—	$10^{13}    6$	—	$\Omega    pF$	
<b>Common Mode</b>						
Common Mode Input Voltage Range	$V_{CMR}$	$V_{SS}-0.3$	—	$V_{DD}+0.3$	V	
Common Mode Rejection Ratio	CMRR	60	76	—	dB	$V_{CM} = -0.3V$ to $6.3V$ , $V_{DD} = 6.0V$
<b>Open-Loop Gain</b>						
DC Open-Loop Gain (Large Signal)	$A_{OL}$	90	110	—	dB	$V_{OUT} = 0.1V$ to $V_{DD}-0.1V$ $R_L = 10 k\Omega$ to $V_L$
<b>Output</b>						
Maximum Output Voltage Swing	$V_{OL}, V_{OH}$	$V_{SS}+20$	—	$V_{DD}-20$	mV	$V_{DD} = 6.0V$ , $R_L = 10 k\Omega$ 0.5V input overdrive
Output Short-Circuit Current	$I_{SC}$	—	$\pm 3$	—	mA	$V_{DD} = 1.4V$
		—	$\pm 22$	—	mA	$V_{DD} = 6.0V$
<b>Power Supply</b>						
Supply Voltage	$V_{DD}$	1.4	—	6.0	V	
Quiescent Current per Amplifier	$I_Q$	250	450	650	nA	$I_O = 0$ , $V_{DD} = 5.0V$

# MCP6441/2/4

## AC ELECTRICAL SPECIFICATIONS

**Electrical Characteristics:** Unless otherwise indicated,  $T_A = +25^\circ\text{C}$ ,  $V_{DD} = +1.4\text{V}$  to  $+6.0\text{V}$ ,  $V_{SS} = \text{GND}$ ,  $V_{CM} = V_{DD}/2$ ,  $V_{OUT} \approx V_{DD}/2$ ,  $V_L = V_{DD}/2$ ,  $R_L = 1\text{ M}\Omega$  to  $V_L$  and  $C_L = 60\text{ pF}$ . (Refer to [Figure 1-1](#)).

Parameters	Sym	Min	Typ	Max	Units	Conditions
<b>AC Response</b>						
Gain Bandwidth Product	GBWP	—	9	—	kHz	
Phase Margin	PM	—	65	—	°	$G = +1\text{ V/V}$
Slew Rate	SR	—	3	—	V/ms	
<b>Noise</b>						
Input Noise Voltage	$E_{ni}$	—	5	—	$\mu\text{Vp-p}$	$f = 0.1\text{ Hz to }10\text{ Hz}$
Input Noise Voltage Density	$e_{ni}$	—	190	—	$\text{nV}/\sqrt{\text{Hz}}$	$f = 1\text{ kHz}$
Input Noise Current Density	$i_{ni}$	—	0.6	—	$\text{fA}/\sqrt{\text{Hz}}$	$f = 1\text{ kHz}$

## TEMPERATURE SPECIFICATIONS

**Electrical Characteristics:** Unless otherwise indicated,  $V_{DD} = +1.4\text{V}$  to  $+6.0\text{V}$  and  $V_{SS} = \text{GND}$ .

Parameters	Sym	Min	Typ	Max	Units	Conditions
<b>Temperature Ranges</b>						
Operating Temperature Range	$T_A$	-40	—	+125	°C	Note 1
Storage Temperature Range	$T_A$	-65	—	+150	°C	
<b>Thermal Package Resistances</b>						
Thermal Resistance, 5L-SC70	$\theta_{JA}$	—	331	—	°C/W	
Thermal Resistance, 5L-SOT-23	$\theta_{JA}$	—	220.7	—	°C/W	
Thermal Resistance, 8L-MSOP	$\theta_{JA}$	—	211	—	°C/W	
Thermal Resistance, 8L-SOIC	$\theta_{JA}$	—	149.5	—	°C/W	
Thermal Resistance, 8L-2x3 TDFN	$\theta_{JA}$	—	52.5	—	°C/W	
Thermal Resistance, 14L-SOIC	$\theta_{JA}$	—	95.3	—	°C/W	
Thermal Resistance, 14L-TSSOP	$\theta_{JA}$	—	100	—	°C/W	

**Note 1:** The internal junction temperature ( $T_J$ ) must not exceed the absolute maximum specification of  $+150^\circ\text{C}$ .

### 1.2 Test Circuits

The circuit used for most DC and AC tests is shown in [Figure 1-1](#). This circuit can independently set  $V_{CM}$  and  $V_{OUT}$  (see [Equation 1-1](#)). Note that  $V_{CM}$  is not the circuit's Common Mode voltage ( $(V_P + V_M)/2$ ), and that  $V_{OST}$  includes  $V_{OS}$  plus the effects (on the input offset error,  $V_{OST}$ ) of the temperature, CMRR, PSRR and  $A_{OL}$ .

#### EQUATION 1-1:

$$G_{DM} = R_F/R_G$$

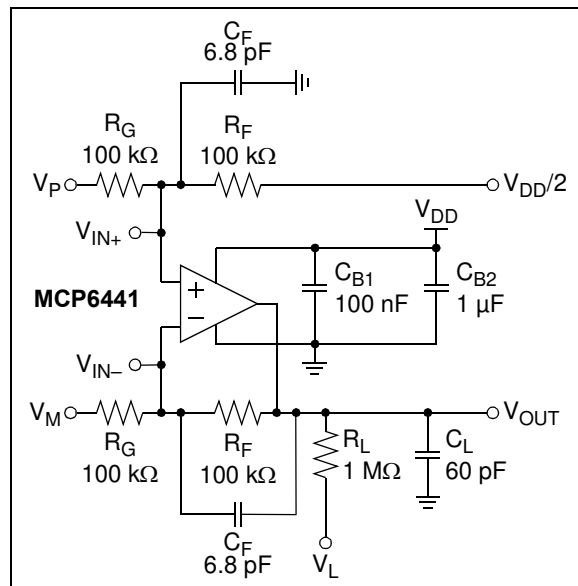
$$V_{CM} = (V_P + V_{DD}/2)/2$$

$$V_{OST} = V_{IN-} - V_{IN+}$$

$$V_{OUT} = (V_{DD}/2) + (V_P - V_M) + V_{OST}(1 + G_{DM})$$

Where:

$G_{DM}$	= Differential Mode Gain	(V/V)
$V_{CM}$	= Op Amp's Common Mode Input Voltage	(V)
$V_{OST}$	= Op Amp's Total Input Offset Voltage	(mV)

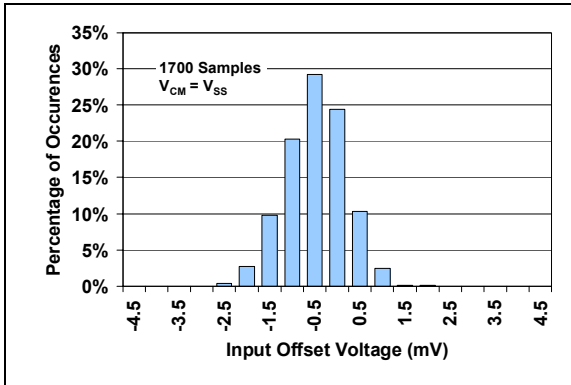


**FIGURE 1-1:** AC and DC Test Circuit for Most Specifications.

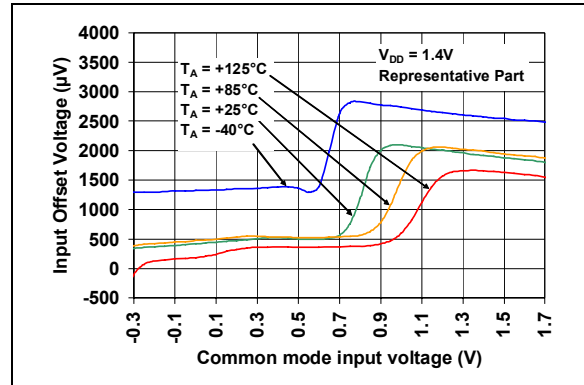
## 2.0 TYPICAL PERFORMANCE CURVES

**Note:** The graphs and tables provided following this note are a statistical summary based on a limited number of samples and are provided for informational purposes only. The performance characteristics listed herein are not tested or guaranteed. In some graphs or tables, the data presented may be outside the specified operating range (e.g., outside specified power supply range) and therefore outside the warranted range.

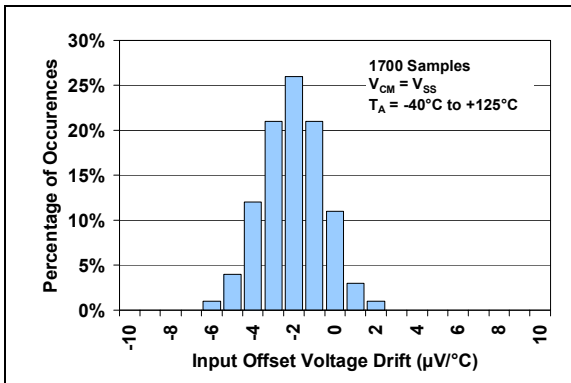
**Note:** Unless otherwise indicated,  $T_A = +25^\circ\text{C}$ ,  $V_{DD} = +1.4\text{V}$  to  $+6.0\text{V}$ ,  $V_{SS} = \text{GND}$ ,  $V_{CM} = V_{DD}/2$ ,  $V_{OUT} \approx V_{DD}/2$ ,  $V_L = V_{DD}/2$ ,  $R_L = 1\text{ M}\Omega$  to  $V_L$  and  $C_L = 60\text{ pF}$ .



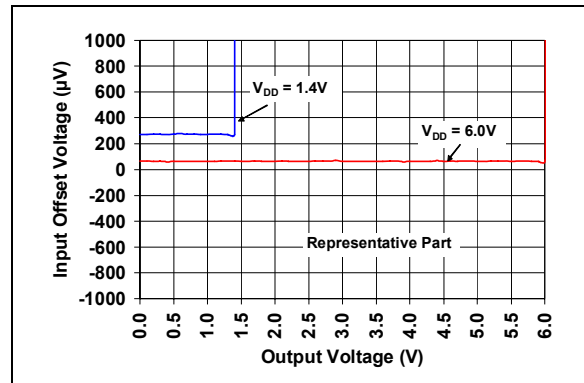
**FIGURE 2-1:** Input Offset Voltage.



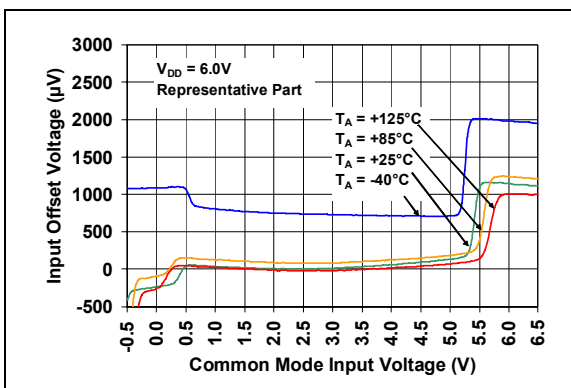
**FIGURE 2-4:** Input Offset Voltage vs. Common Mode Input Voltage with  $V_{DD} = 1.4\text{V}$ .



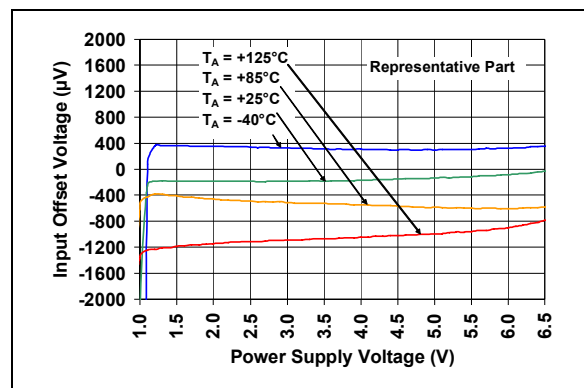
**FIGURE 2-2:** Input Offset Voltage Drift.



**FIGURE 2-5:** Input Offset Voltage vs. Output Voltage.



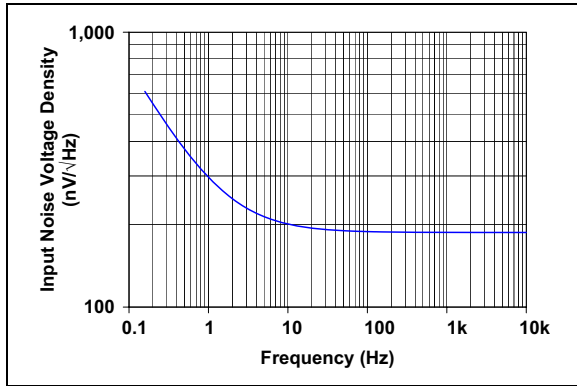
**FIGURE 2-3:** Input Offset Voltage vs. Common Mode Input Voltage with  $V_{DD} = 6.0\text{V}$ .



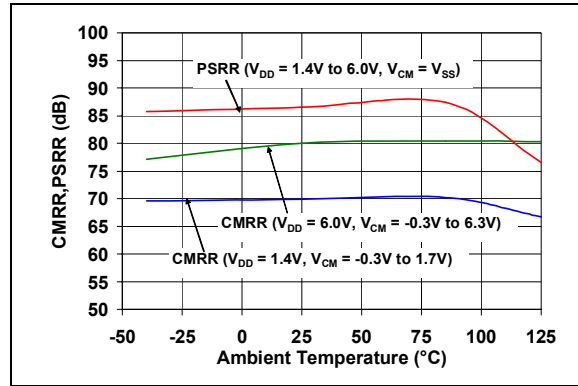
**FIGURE 2-6:** Input Offset Voltage vs. Power Supply Voltage.

# MCP6441/2/4

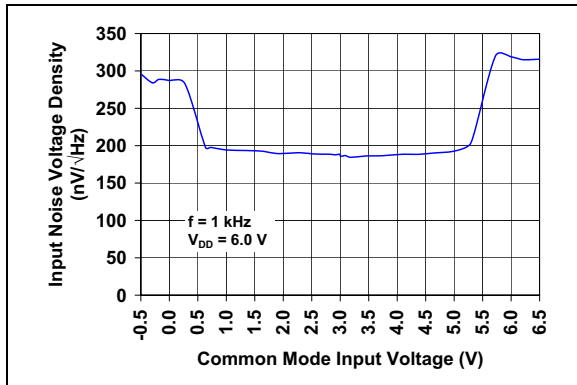
**Note:** Unless otherwise indicated,  $T_A = +25^\circ\text{C}$ ,  $V_{DD} = +1.4\text{V}$  to  $+6.0\text{V}$ ,  $V_{SS} = \text{GND}$ ,  $V_{CM} = V_{DD}/2$ ,  $V_{OUT} \approx V_{DD}/2$ ,  $V_L = V_{DD}/2$ ,  $R_L = 1\text{ M}\Omega$  to  $V_L$  and  $C_L = 60\text{ pF}$ .



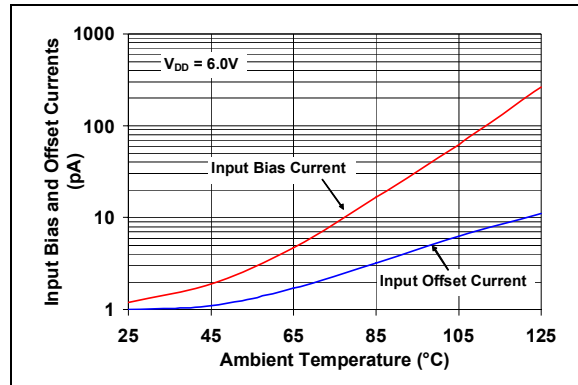
**FIGURE 2-7:** Input Noise Voltage Density vs. Frequency.



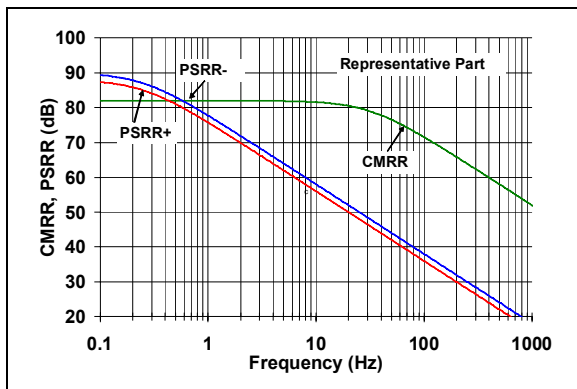
**FIGURE 2-10:** CMRR, PSRR vs. Ambient Temperature.



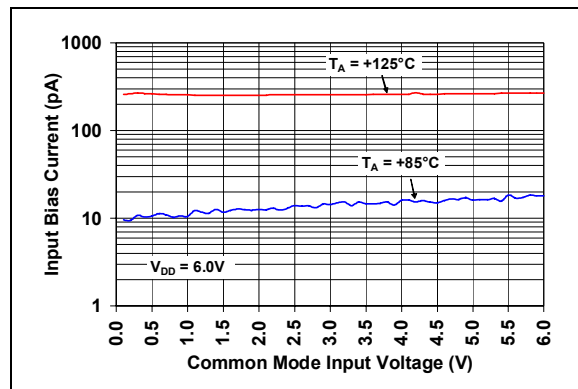
**FIGURE 2-8:** Input Noise Voltage Density vs. Common Mode Input Voltage.



**FIGURE 2-11:** Input Bias, Offset Current vs. Ambient Temperature.

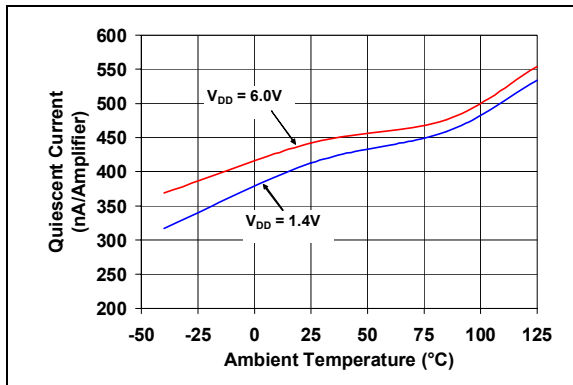


**FIGURE 2-9:** CMRR, PSRR vs. Frequency.

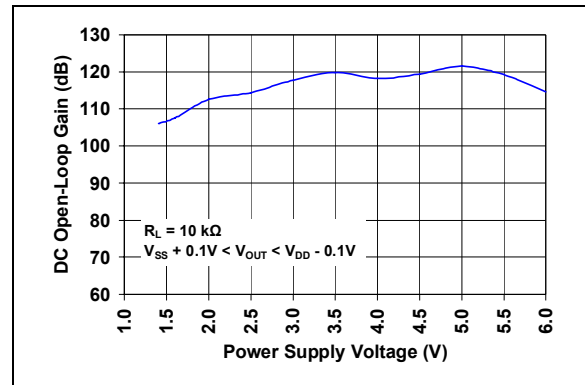


**FIGURE 2-12:** Input Bias Current vs. Common Mode Input Voltage.

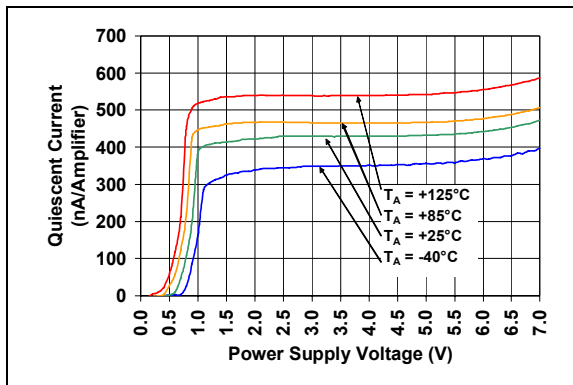
**Note:** Unless otherwise indicated,  $T_A = +25^\circ\text{C}$ ,  $V_{DD} = +1.4\text{V}$  to  $+6.0\text{V}$ ,  $V_{SS} = \text{GND}$ ,  $V_{CM} = V_{DD}/2$ ,  $V_{OUT} \approx V_{DD}/2$ ,  $V_L = V_{DD}/2$ ,  $R_L = 1\text{ M}\Omega$  to  $V_L$  and  $C_L = 60\text{ pF}$ .



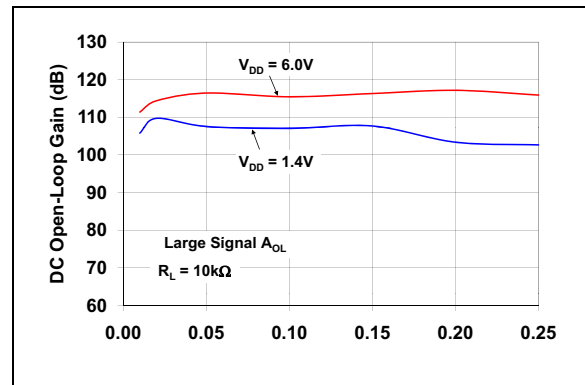
**FIGURE 2-13:** Quiescent Current vs. Ambient Temperature.



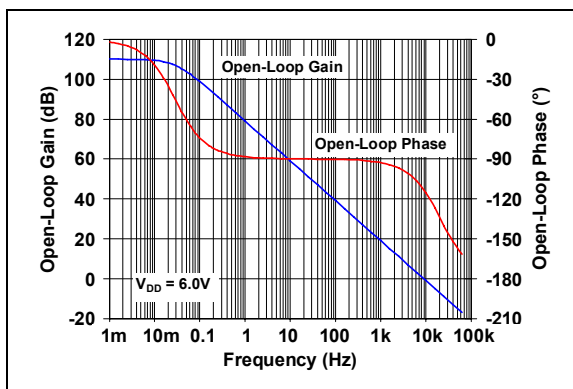
**FIGURE 2-16:** DC Open-Loop Gain vs. Power Supply Voltage.



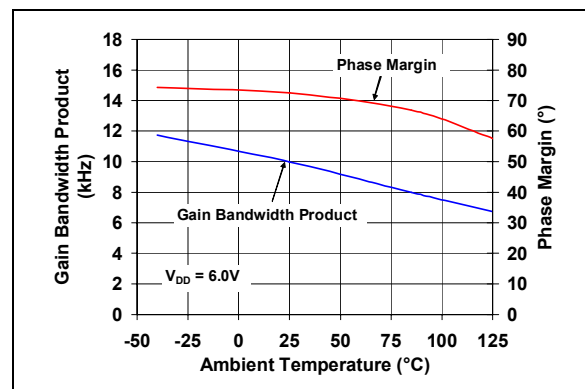
**FIGURE 2-14:** Quiescent Current vs. Power Supply Voltage.



**FIGURE 2-17:** DC Open-Loop Gain vs. Output Voltage Headroom.



**FIGURE 2-15:** Open-Loop Gain, Phase vs. Frequency.

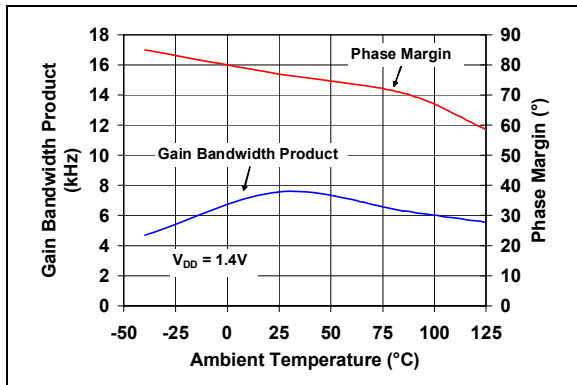


**FIGURE 2-18:** Gain Bandwidth Product, Phase Margin vs. Ambient Temperature.

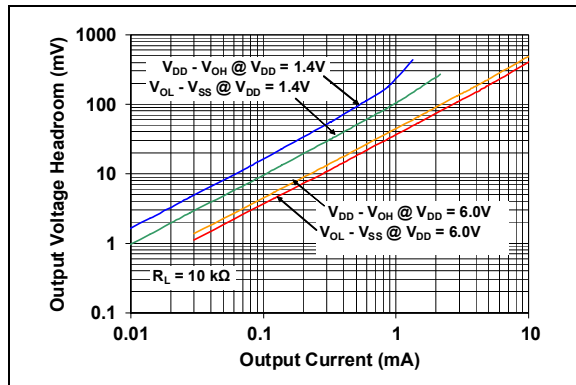


# MCP6441/2/4

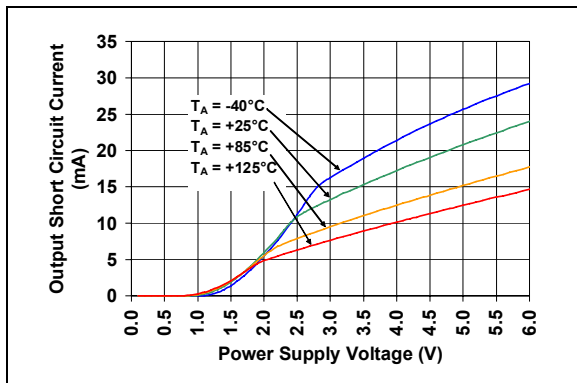
**Note:** Unless otherwise indicated,  $T_A = +25^\circ\text{C}$ ,  $V_{DD} = +1.4\text{V}$  to  $+6.0\text{V}$ ,  $V_{SS} = \text{GND}$ ,  $V_{CM} = V_{DD}/2$ ,  $V_{OUT} \approx V_{DD}/2$ ,  $V_L = V_{DD}/2$ ,  $R_L = 1\text{ M}\Omega$  to  $V_L$  and  $C_L = 60\text{ pF}$ .



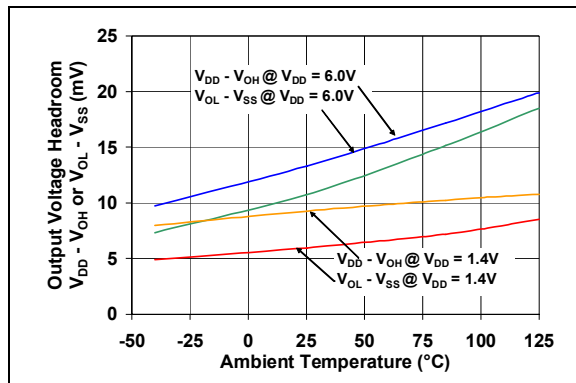
**FIGURE 2-19:** Gain Bandwidth Product, Phase Margin vs. Ambient Temperature.



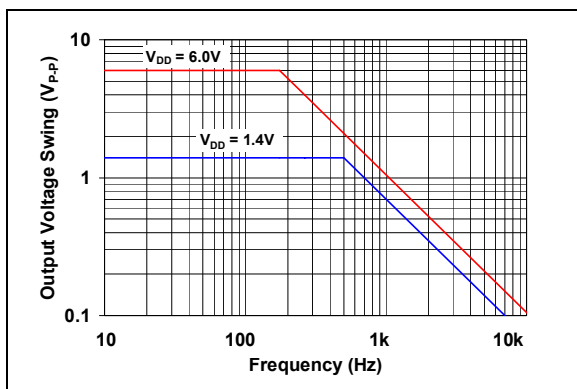
**FIGURE 2-22:** Output Voltage Headroom vs. Output Current.



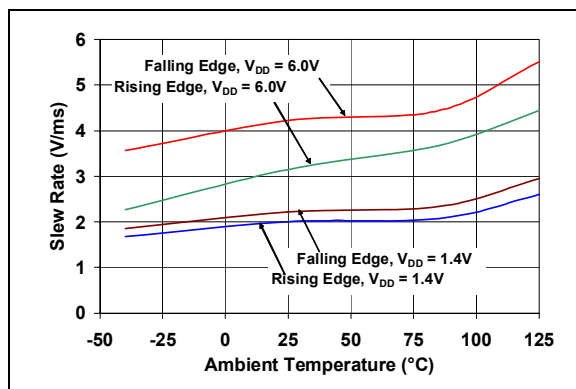
**FIGURE 2-20:** Output Short Circuit Current vs. Power Supply Voltage.



**FIGURE 2-23:** Output Voltage Headroom vs. Ambient Temperature.

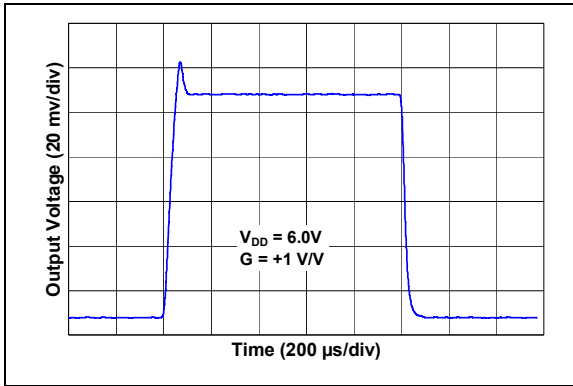


**FIGURE 2-21:** Output Voltage Swing vs. Frequency.

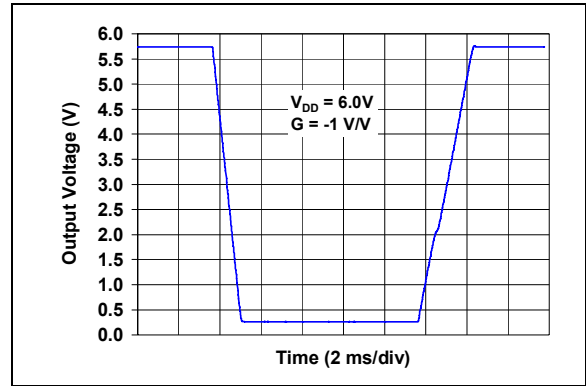


**FIGURE 2-24:** Slew Rate vs. Ambient Temperature.

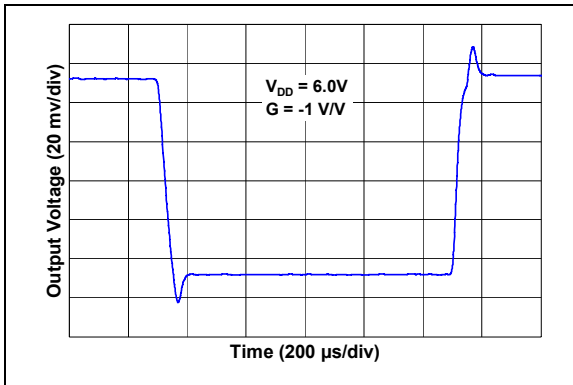
**Note:** Unless otherwise indicated,  $T_A = +25^\circ\text{C}$ ,  $V_{DD} = +1.4\text{V}$  to  $+6.0\text{V}$ ,  $V_{SS} = \text{GND}$ ,  $V_{CM} = V_{DD}/2$ ,  $V_{OUT} \approx V_{DD}/2$ ,  $V_L = V_{DD}/2$ ,  $R_L = 1\text{ M}\Omega$  to  $V_L$  and  $C_L = 60\text{ pF}$ .



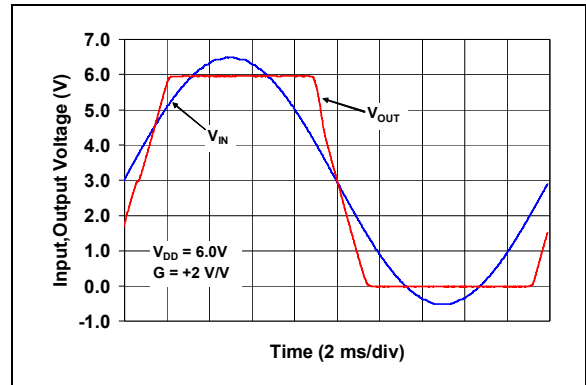
**FIGURE 2-25:** Small Signal Non-Inverting Pulse Response.



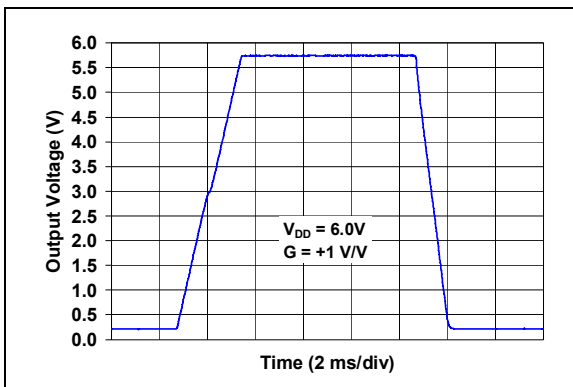
**FIGURE 2-28:** Large Signal Inverting Pulse Response.



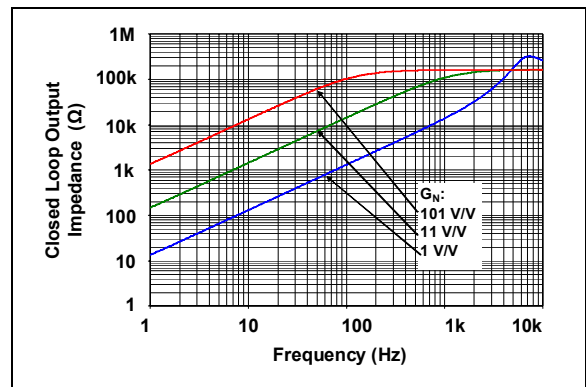
**FIGURE 2-26:** Small Signal Inverting Pulse Response.



**FIGURE 2-29:** The MCP6441/2/4 Device Shows No Phase Reversal.



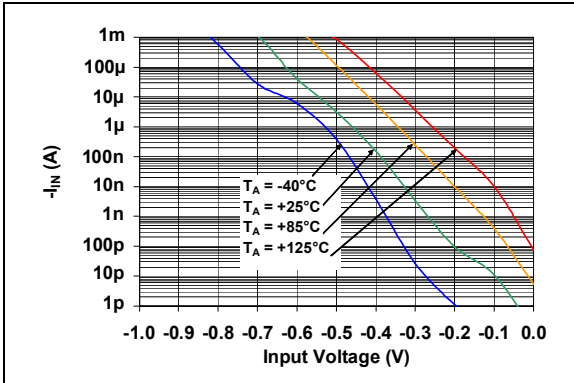
**FIGURE 2-27:** Large Signal Non-Inverting Pulse Response.



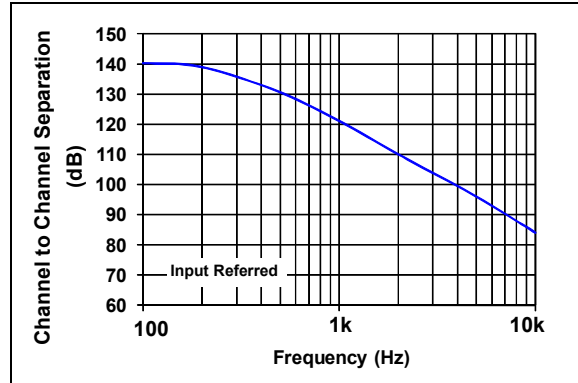
**FIGURE 2-30:** Closed Loop Output Impedance vs. Frequency.

# MCP6441/2/4

**Note:** Unless otherwise indicated,  $T_A = +25^\circ\text{C}$ ,  $V_{DD} = +1.4\text{V}$  to  $+6.0\text{V}$ ,  $V_{SS} = \text{GND}$ ,  $V_{CM} = V_{DD}/2$ ,  $V_{OUT} \approx V_{DD}/2$ ,  $V_L = V_{DD}/2$ ,  $R_L = 1\text{ M}\Omega$  to  $V_L$  and  $C_L = 60\text{ pF}$ .



**FIGURE 2-31:** Measured Input Current vs. Input Voltage (below  $V_{SS}$ ).



**FIGURE 2-32:** Channel-to-Channel Separation vs. Frequency (MCP6442/4 only).

## 3.0 PIN DESCRIPTIONS

Descriptions of the pins are listed in [Table 3-1](#).

**TABLE 3-1: PIN FUNCTION TABLE**

MCP6441 SC70-5, SOT-23-5	MCP6442		MCP6444 SOIC, TSSOP	Symbol	Description
	SOIC, MSOP	2x3 TDFN			
1	1	1	1	$V_{OUT}, V_{OUTA}$	Analog Output (op amp A)
4	2	2	2	$V_{IN-}, V_{INA-}$	Inverting Input (op amp A)
3	3	3	3	$V_{IN+}, V_{INA+}$	Non-inverting Input (op amp A)
5	8	8	4	$V_{DD}$	Positive Power Supply
—	5	5	5	$V_{INB+}$	Non-inverting Input (op amp B)
—	6	6	6	$V_{INB-}$	Inverting Input (op amp B)
—	7	7	7	$V_{OUTB}$	Analog Output (op amp B)
—	—	—	8	$V_{OUTC}$	Analog Output (op amp C)
—	—	—	9	$V_{INC-}$	Inverting Input (op amp C)
—	—	—	10	$V_{INC+}$	Non-inverting Input (op amp C)
2	4	4	11	$V_{SS}$	Negative Power Supply
—	—	—	12	$V_{IND+}$	Non-inverting Input (op amp D)
—	—	—	13	$V_{IND-}$	Inverting Input (op amp D)
—	—	—	14	$V_{OUTD}$	Analog Output (op amp D)
—	—	9	—	EP	Exposed Thermal Pad (EP); must be connected to $V_{SS}$

### 3.1 Analog Output ( $V_{OUT}$ )

The output pin is a low-impedance voltage source.

### 3.2 Power Supply Pins ( $V_{DD}, V_{SS}$ )

The positive power supply ( $V_{DD}$ ) is 1.4V to 6.0V higher than the negative power supply ( $V_{SS}$ ). For normal operation, the other pins are at voltages between  $V_{SS}$  and  $V_{DD}$ .

Typically, these parts are used in a single (positive) supply configuration. In this case,  $V_{SS}$  is connected to ground and  $V_{DD}$  is connected to the supply.  $V_{DD}$  will need bypass capacitors.

### 3.3 Analog Inputs ( $V_{IN+}, V_{IN-}$ )

The non-inverting and inverting inputs are high-impedance CMOS inputs with low bias currents.

### 3.4 Exposed Thermal Pad (EP)

There is an internal connection between the Exposed Thermal Pad (EP) and the  $V_{SS}$  pin; they must be connected to the same potential on the Printed Circuit Board (PCB).

This pad can be connected to a PCB ground plane to provide a larger heat sink. This improves the package thermal resistance ( $\theta_{JA}$ ).

# MCP6441/2/4

---

Notes:

## 4.0 APPLICATION INFORMATION

The MCP6441/2/4 op amp is manufactured using Microchip's state-of-the-art CMOS process, specifically designed for low power applications.

### 4.1 Rail-to-Rail Input

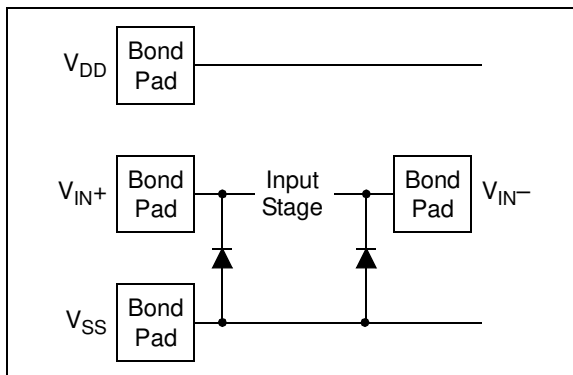
#### 4.1.1 PHASE REVERSAL

The MCP6441/2/4 op amp is designed to prevent phase reversal, when the input pins exceed the supply voltages. Figure 2-29 shows the input voltage exceeding the supply voltage with no phase reversal.

#### 4.1.2 INPUT VOLTAGE LIMITS

In order to prevent damage and/or improper operation of the amplifier, the circuit must limit the voltages at the input pins (see Section 1.1, **Absolute Maximum Ratings †**).

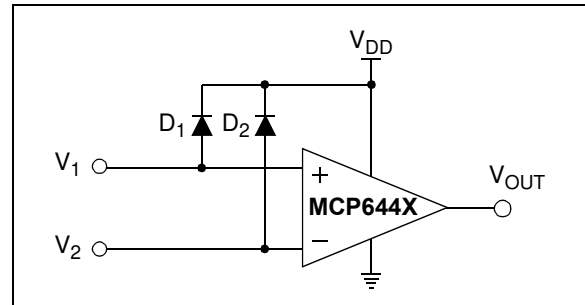
The Electrostatic Discharge (ESD) protection on the inputs can be depicted as shown in Figure 4-1. This structure was chosen to protect the input transistors against many, but not all, over-voltage conditions, and to minimize the input bias current ( $I_B$ ).



**FIGURE 4-1:** Simplified Analog Input ESD Structures.

The input ESD diodes clamp the inputs when they try to go more than one diode drop below  $V_{SS}$ . They also clamp any voltages that go well above  $V_{DD}$ ; their breakdown voltage is high enough to allow normal operation, but not low enough to protect against slow over-voltage (beyond  $V_{DD}$ ) events. Very fast ESD events that meet the spec are limited so that damage does not occur.

In some applications, it may be necessary to prevent excessive voltages from reaching the op amp inputs; Figure 4-2 shows one approach to protecting these inputs.



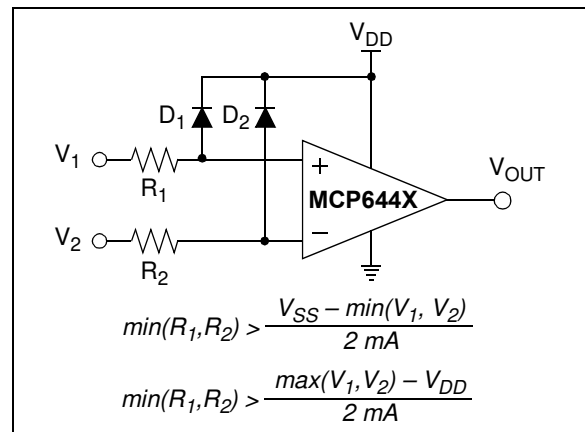
**FIGURE 4-2:** Protecting the Analog Inputs.

A significant amount of current can flow out of the inputs when the Common Mode voltage ( $V_{CM}$ ) is below ground ( $V_{SS}$ ); see Figure 2-31.

#### 4.1.3 INPUT CURRENT LIMITS

In order to prevent damage and/or improper operation of the amplifier, the circuit must limit the currents into the input pins (see Section 1.1 "Absolute Maximum Ratings †").

Figure 4-3 shows one approach to protecting these inputs. The resistors  $R_1$  and  $R_2$  limit the possible currents in or out of the input pins (and the ESD diodes,  $D_1$  and  $D_2$ ). The diode currents will go through either  $V_{DD}$  or  $V_{SS}$ .



$$\min(R_1, R_2) > \frac{V_{SS} - \min(V_1, V_2)}{2 \text{ mA}}$$

$$\min(R_1, R_2) > \frac{\max(V_1, V_2) - V_{DD}}{2 \text{ mA}}$$

**FIGURE 4-3:** Protecting the Analog Inputs.

# MCP6441/2/4

## 4.1.4 NORMAL OPERATION

The input stage of the MCP6441/2/4 op amp uses two differential input stages in parallel. One operates at a low Common Mode input voltage ( $V_{CM}$ ), while the other operates at a high  $V_{CM}$ . With this topology, the device operates with a  $V_{CM}$  up to 300 mV above  $V_{DD}$  and 300 mV below  $V_{SS}$ . The input offset voltage is measured at  $V_{CM} = V_{SS} - 0.3V$  and  $V_{DD} + 0.3V$ , to ensure proper operation.

The transition between the input stages occurs when  $V_{CM}$  is near  $V_{DD} - 0.6V$  (see Figures 2-3 and 2-4). For the best distortion performance and gain linearity, with non-inverting gains, avoid this region of operation.

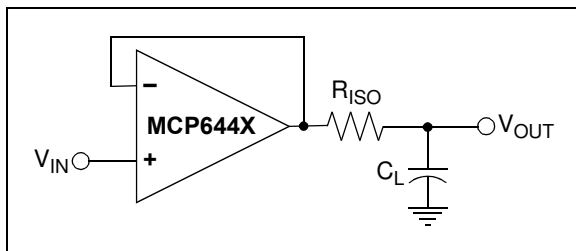
## 4.2 Rail-to-Rail Output

The output voltage range of the MCP6441/2/4 op amp is  $V_{SS} + 20$  mV (minimum) and  $V_{DD} - 20$  mV (maximum) when  $R_L = 10$  k $\Omega$  is connected to  $V_{DD}/2$  and  $V_{DD} = 6.0V$ . Refer to Figures 2-22 and 2-23 for more information.

## 4.3 Capacitive Loads

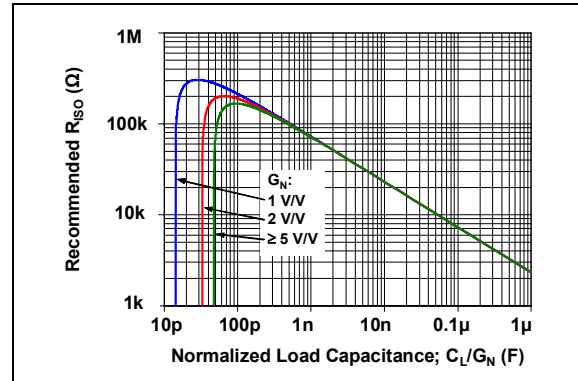
Driving large capacitive loads can cause stability problems for voltage feedback op amps. As the load capacitance increases, the feedback loop's phase margin decreases, and the closed-loop bandwidth is reduced. This produces gain peaking in the frequency response, with overshoot and ringing in the step response. While a unity-gain buffer ( $G = +1$  V/V) is the most sensitive to the capacitive loads, all gains show the same general behavior.

When driving large capacitive loads with the MCP6441/2/4 op amp (e.g.,  $> 100$  pF when  $G = +1$  V/V), a small series resistor at the output ( $R_{ISO}$  in Figure 4-4) improves the feedback loop's phase margin (stability) by making the output load resistive at higher frequencies. The bandwidth will be generally lower than the bandwidth with no capacitance load.



**FIGURE 4-4:** Output Resistor,  $R_{ISO}$  Stabilizes Large Capacitive Loads.

Figure 4-5 gives the recommended  $R_{ISO}$  values for the different capacitive loads and gains. The x-axis is the normalized load capacitance ( $C_L/G_N$ ), where  $G_N$  is the circuit's noise gain. For non-inverting gains,  $G_N$  and the Signal Gain are equal. For inverting gains,  $G_N$  is  $1 + |\text{Signal Gain}|$  (e.g.,  $-1$  V/V gives  $G_N = +2$  V/V).



**FIGURE 4-5:** Recommended  $R_{ISO}$  Values for Capacitive Loads.

After selecting  $R_{ISO}$  for your circuit, double-check the resulting frequency response peaking and step response overshoot. Modify  $R_{ISO}$ 's value until the response is reasonable. Bench evaluation and simulations with the MCP6441/2/4 SPICE macro model are very helpful.

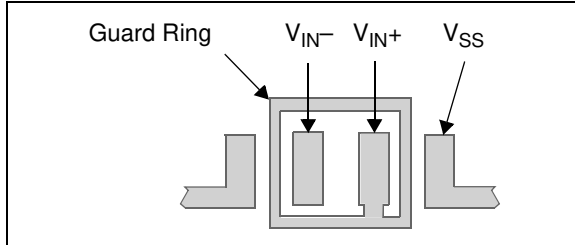
## 4.4 Supply Bypass

The MCP6441/2/4 op amp's power supply pin ( $V_{DD}$  for single-supply) should have a local bypass capacitor (i.e.,  $0.01$   $\mu F$  to  $0.1$   $\mu F$ ) within 2 mm for good high frequency performance. It can use a bulk capacitor (i.e.,  $1$   $\mu F$  or larger) within 100 mm to provide large, slow currents. This bulk capacitor can be shared with other analog parts.

## 4.5 PCB Surface Leakage

In applications where low input bias current is critical, Printed Circuit Board (PCB) surface leakage effects need to be considered. Surface leakage is caused by humidity, dust or other contamination on the board. Under low humidity conditions, a typical resistance between nearby traces is  $10^{12}$   $\Omega$ . A 5V difference would cause 5 pA of current to flow, which is greater than the MCP6441/2/4 op amp's bias current at  $+25^\circ C$  ( $\pm 1$  pA, typical).

The easiest way to reduce surface leakage is to use a guard ring around sensitive pins (or traces). The guard ring is biased at the same voltage as the sensitive pin. An example of this type of layout is shown in Figure 4-6.



**FIGURE 4-6:** Example Guard Ring Layout for Inverting Gain.

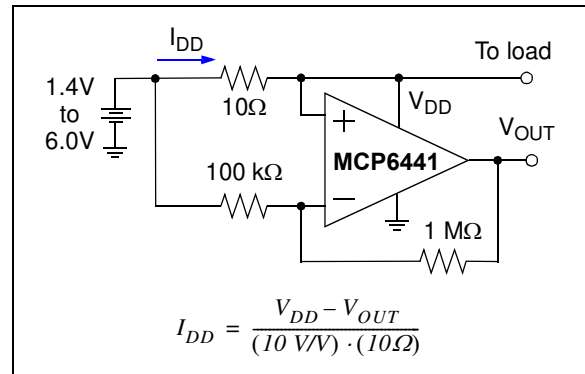
1. Non-inverting Gain and Unity-Gain Buffer:
  - a) Connect the non-inverting pin ( $V_{IN+}$ ) to the input with a wire that does not touch the PCB surface.
  - b) Connect the guard ring to the inverting input pin ( $V_{IN-}$ ). This biases the guard ring to the Common Mode input voltage.
2. Inverting Gain and Transimpedance Gain Amplifiers (convert current to voltage, such as photo detectors):
  - a) Connect the guard ring to the non-inverting input pin ( $V_{IN+}$ ). This biases the guard ring to the same reference voltage as the op amp (e.g.,  $V_{DD}/2$  or ground).
  - b) Connect the inverting pin ( $V_{IN-}$ ) to the input with a wire that does not touch the PCB surface.

## 4.6 Application Circuits

### 4.6.1 BATTERY CURRENT SENSING

The MCP6441/2/4 op amp's Common Mode Input Range, which goes 0.3V beyond both supply rails, supports their use in high-side and low-side battery current sensing applications. The low quiescent current (450 nA, typical) helps prolong battery life, and the rail-to-rail output supports detection of low currents.

Figure 4-7 shows a high side battery current sensor circuit. The  $10\Omega$  resistor is sized to minimize power losses. The battery current ( $I_{DD}$ ) through the  $10\Omega$  resistor causes its top terminal to be more negative than the bottom terminal. This keeps the Common Mode input voltage of the op amp below  $V_{DD}$ , which is within its allowed range. The output of the op amp will also be below  $V_{DD}$ , within its Maximum Output Voltage Swing specification.



**FIGURE 4-7:** Battery Current Sensing.



# MCP6441/2/4

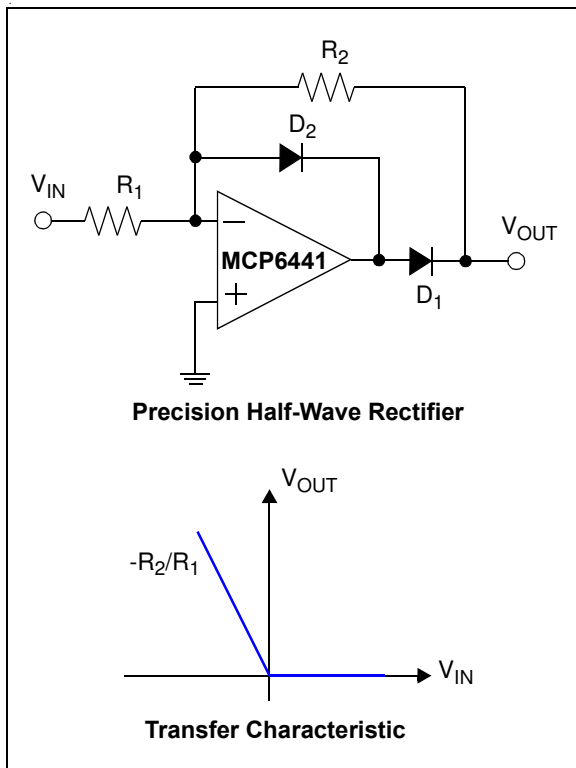
## 4.6.2 PRECISION HALF-WAVE RECTIFIER

The precision half-wave rectifier, which is also known as a super diode, is a configuration obtained with an operational amplifier in order to have a circuit behaving like an ideal diode and rectifier. It effectively cancels the forward voltage drop of the diode in such a way that very low level signals can still be rectified, with minimal error. This can be useful for high-precision signal processing. The MCP6441/2/4 op amp has high input impedance, low input bias current and rail-to-rail input/output, which makes this device suitable for precision rectifier applications.

Figure 4-8 shows a precision half-wave rectifier and its transfer characteristic. The rectifier's input impedance is determined by the input resistor  $R_1$ . To avoid the loading effect, it must be driven from a low-impedance source.

When  $V_{IN}$  is greater than zero,  $D_1$  is OFF,  $D_2$  is ON, and  $V_{OUT}$  is zero. When  $V_{IN}$  is less than zero,  $D_1$  is ON,  $D_2$  is OFF, and  $V_{OUT}$  is the  $V_{IN}$  with an amplification of  $-R_2/R_1$ .

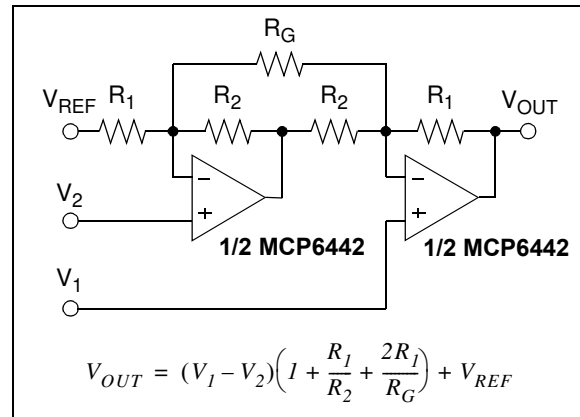
The rectifier circuit shown in Figure 4-8 has the benefit that the op amp never goes into saturation, so the only thing affecting its frequency response is the amplification and the gain bandwidth product.



**FIGURE 4-8:** Precision Half-Wave Rectifier.

## 4.6.3 INSTRUMENTATION AMPLIFIER

The MCP6441/2/4 op amp is well suited for conditioning sensor signals in battery-powered applications. Figure 4-9 shows a two op amp instrumentation amplifier, using the MCP6441/2/4 device, that works well for applications requiring rejection of Common Mode noise at higher gains. The reference voltage ( $V_{REF}$ ) is supplied by a low-impedance source. In single supply applications,  $V_{REF}$  is typically  $V_{DD}/2$ .



**FIGURE 4-9:** Two Op Amp Instrumentation Amplifier.

## 5.0 DESIGN AIDS

Microchip provides the basic design tools needed for the MCP6441/2/4 op amp.

### 5.1 SPICE Macro Model

The latest SPICE macro model for the MCP6441/2/4 op amp is available on the Microchip web site at [www.microchip.com](http://www.microchip.com). The model was written and tested in the official OrCAD (Cadence®) owned PSpice®. For the other simulators, translation may be required.

The model covers a wide aspect of the op amp's electrical specifications. Not only does the model cover voltage, current and resistance of the op amp, but it also covers the temperature and the noise effects on the behavior of the op amp. The model has not been verified outside of the specification range listed in the op amp data sheet. The model behaviors under these conditions cannot ensure it will match the actual op amp performance.

Moreover, the model is intended to be an initial design tool. Bench testing is a very important part of any design and cannot be replaced with simulations. Also, simulation results using this macro model need to be validated by comparing them to the data sheet specifications and characteristic curves.

### 5.2 FilterLab® Software

Microchip's FilterLab software is an innovative software tool that simplifies analog active filter design using op amps. Available at no cost from the Microchip web site at [www.microchip.com/filterlab](http://www.microchip.com/filterlab), the FilterLab design tool provides full schematic diagrams of the filter circuit with component values. It also outputs the filter circuit in SPICE format, which can be used with the macro model to simulate the actual filter performance.

### 5.3 Microchip Advanced Part Selector (MAPS)

MAPS is a software tool that helps semiconductor professionals efficiently identify the Microchip devices that fit a particular design requirement. Available at no cost from the Microchip website at [www.microchip.com/maps](http://www.microchip.com/maps), the MAPS is an overall selection tool for Microchip's product portfolio that includes Analog, Memory, MCUs and DSCs. Using this tool, you can define a filter to sort features for a parametric search of devices and export side-by-side technical comparison reports. Helpful links are also provided for Data Sheets, Purchase and Sampling of Microchip parts.

## 5.4 Analog Demonstration and Evaluation Boards

Microchip offers a broad spectrum of Analog Demonstration and Evaluation Boards that are designed to help you achieve faster time to market. For a complete listing of these boards and their corresponding user's guides and technical information, visit the Microchip web site at [www.microchip.com/analogtools](http://www.microchip.com/analogtools).

Some boards that are especially useful are:

- MCP6XXX Amplifier Evaluation Board 1
- MCP6XXX Amplifier Evaluation Board 2
- MCP6XXX Amplifier Evaluation Board 3
- MCP6XXX Amplifier Evaluation Board 4
- Active Filter Demo Board Kit
- 5/6-Pin SOT-23 Evaluation Board, P/N VSUPEV2

## 5.5 Application Notes

The following Microchip Analog Design Note and Application Notes are available on the Microchip web site at [www.microchip.com/appnotes](http://www.microchip.com/appnotes), and are recommended as supplemental reference resources.

- **ADN003** – “Select the Right Operational Amplifier for your Filtering Circuits”, DS21821
- **AN722** – “Operational Amplifier Topologies and DC Specifications”, DS00722
- **AN723** – “Operational Amplifier AC Specifications and Applications”, DS00723
- **AN884** – “Driving Capacitive Loads With Op Amps”, DS00884
- **AN990** – “Analog Sensor Conditioning Circuits – An Overview”, DS00990
- **AN1177** – “Op Amp Precision Design: DC Errors”, DS01177
- **AN1228** – “Op Amp Precision Design: Random Noise”, DS01228
- **AN1297** – “Microchip's Op Amp SPICE Macro Models”, DS01297
- **AN1332**: “Current Sensing Circuit Concepts and Fundamentals” DS01332

These application notes and others are listed in the design guide:

- “Signal Chain Design Guide”, DS21825

# MCP6441/2/4

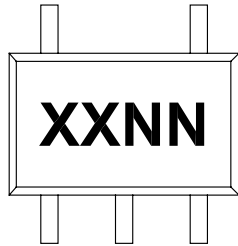
---

NOTES:

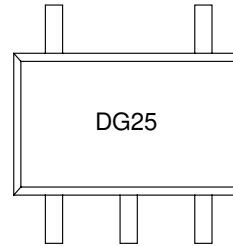
## 6.0 PACKAGING INFORMATION

### 6.1 Package Marking Information

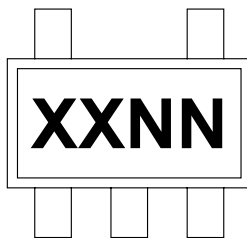
5-Lead SC70 (MCP6441)



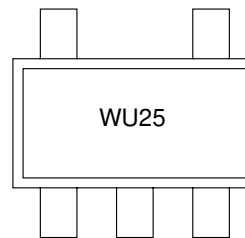
Example:



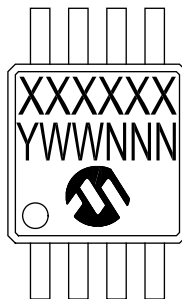
5-Lead SOT-23 (MCP6441)



Example:



8-Lead MSOP (MCP6442)



Example:

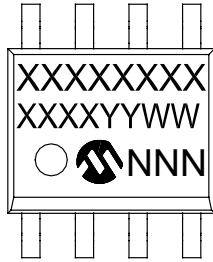


<b>Legend:</b>	XX...X	Customer-specific information
	Y	Year code (last digit of calendar year)
	YY	Year code (last 2 digits of calendar year)
	WW	Week code (week of January 1 is week '01')
	NNN	Alphanumeric traceability code
	(e3)	Pb-free JEDEC designator for Matte Tin (Sn)
	*	This package is Pb-free. The Pb-free JEDEC designator (e3) can be found on the outer packaging for this package.

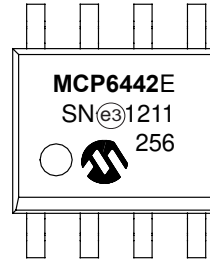
**Note:** In the event the full Microchip part number cannot be marked on one line, it will be carried over to the next line, thus limiting the number of available characters for customer-specific information.

# MCP6441/2/4

8-Lead SOIC (150 mil) (MCP6442)



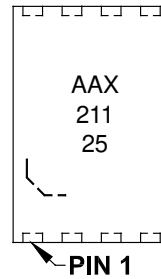
Example:



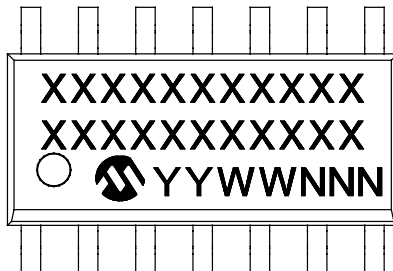
8-Lead TDFN (2x3x0.75 mm)(MCP6442)



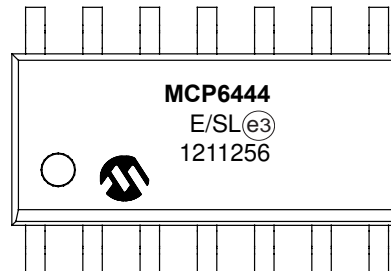
Example:



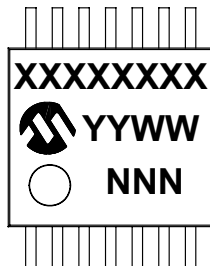
14-Lead SOIC (150 mil) (MCP6444)



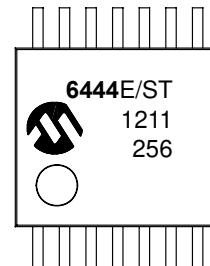
Example:



14-Lead TSSOP (MCP6444)



Example:

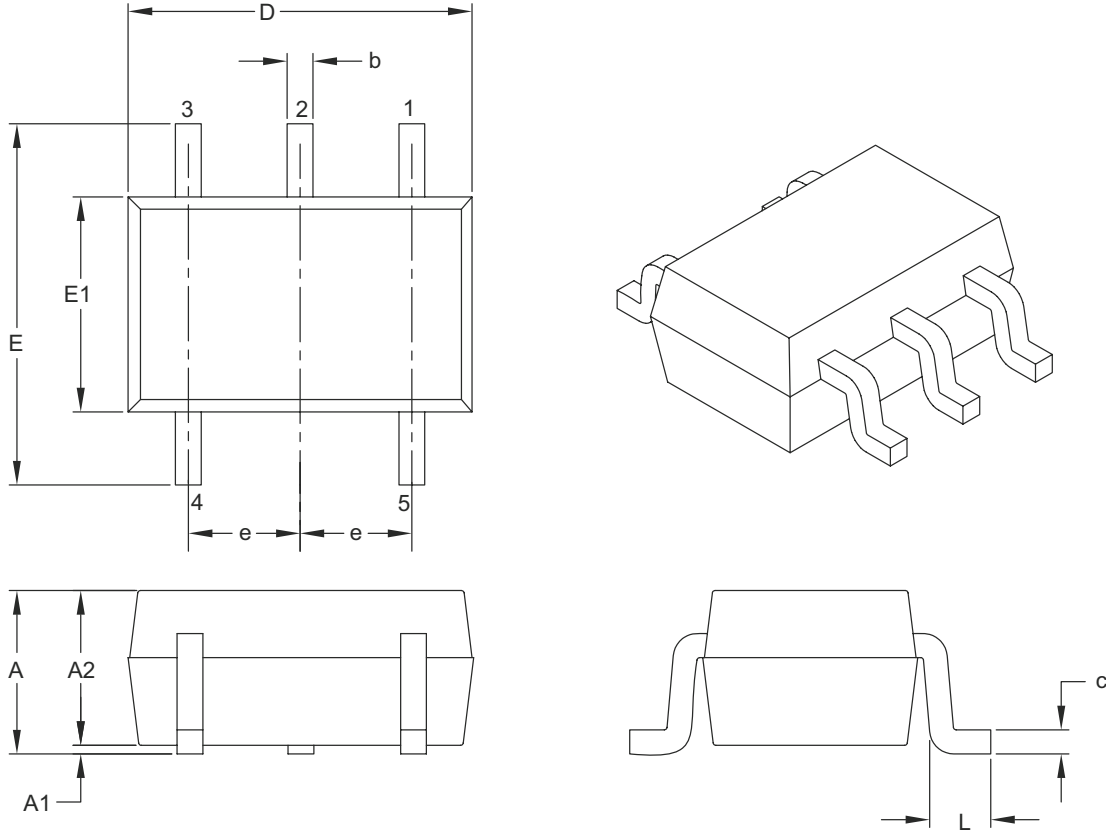


<b>Legend:</b>	XX...X	Customer-specific information
	Y	Year code (last digit of calendar year)
	YY	Year code (last 2 digits of calendar year)
	WW	Week code (week of January 1 is week '01')
	NNN	Alphanumeric traceability code
	(e3)	Pb-free JEDEC designator for Matte Tin (Sn)
	*	This package is Pb-free. The Pb-free JEDEC designator ((e3) can be found on the outer packaging for this package.

**Note:** In the event the full Microchip part number cannot be marked on one line, it will be carried over to the next line, thus limiting the number of available characters for customer-specific information.

## 5-Lead Plastic Small Outline Transistor (LT) [SC70]

**Note:** For the most current package drawings, please see the Microchip Packaging Specification located at <http://www.microchip.com/packaging>



Dimension Limits	Units	MILLIMETERS		
		MIN	NOM	MAX
Number of Pins	N	5		
Pitch	e	0.65 BSC		
Overall Height	A	0.80	–	1.10
Molded Package Thickness	A2	0.80	–	1.00
Standoff	A1	0.00	–	0.10
Overall Width	E	1.80	2.10	2.40
Molded Package Width	E1	1.15	1.25	1.35
Overall Length	D	1.80	2.00	2.25
Foot Length	L	0.10	0.20	0.46
Lead Thickness	c	0.08	–	0.26
Lead Width	b	0.15	–	0.40

**Notes:**

- Dimensions D and E1 do not include mold flash or protrusions. Mold flash or protrusions shall not exceed 0.127 mm per side.
- Dimensioning and tolerancing per ASME Y14.5M.

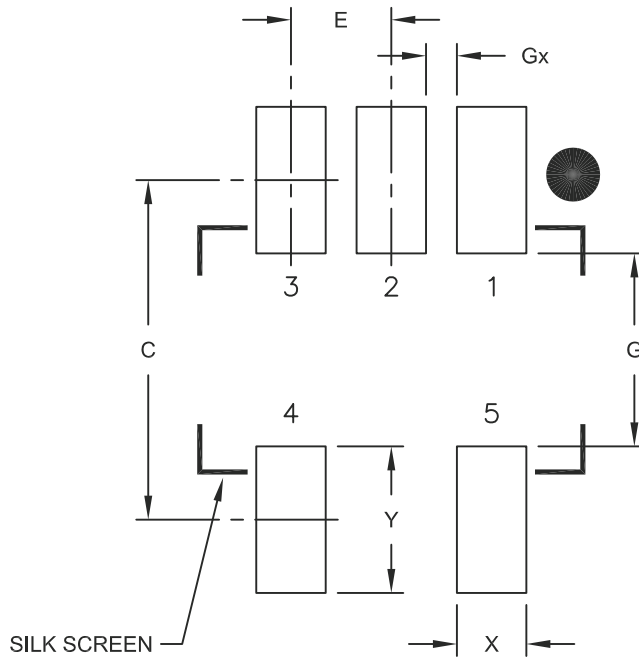
BSC: Basic Dimension. Theoretically exact value shown without tolerances.

Microchip Technology Drawing C04-061B

# MCP6441/2/4

## 5-Lead Plastic Small Outline Transistor (LT) [SC70]

**Note:** For the most current package drawings, please see the Microchip Packaging Specification located at <http://www.microchip.com/packaging>



RECOMMENDED LAND PATTERN

Dimension Limits	Units	MILLIMETERS		
		MIN	NOM	MAX
Contact Pitch	E	0.65 BSC		
Contact Pad Spacing	C		2.20	
Contact Pad Width	X			0.45
Contact Pad Length	Y			0.95
Distance Between Pads	G	1.25		
Distance Between Pads	Gx	0.20		

Notes:

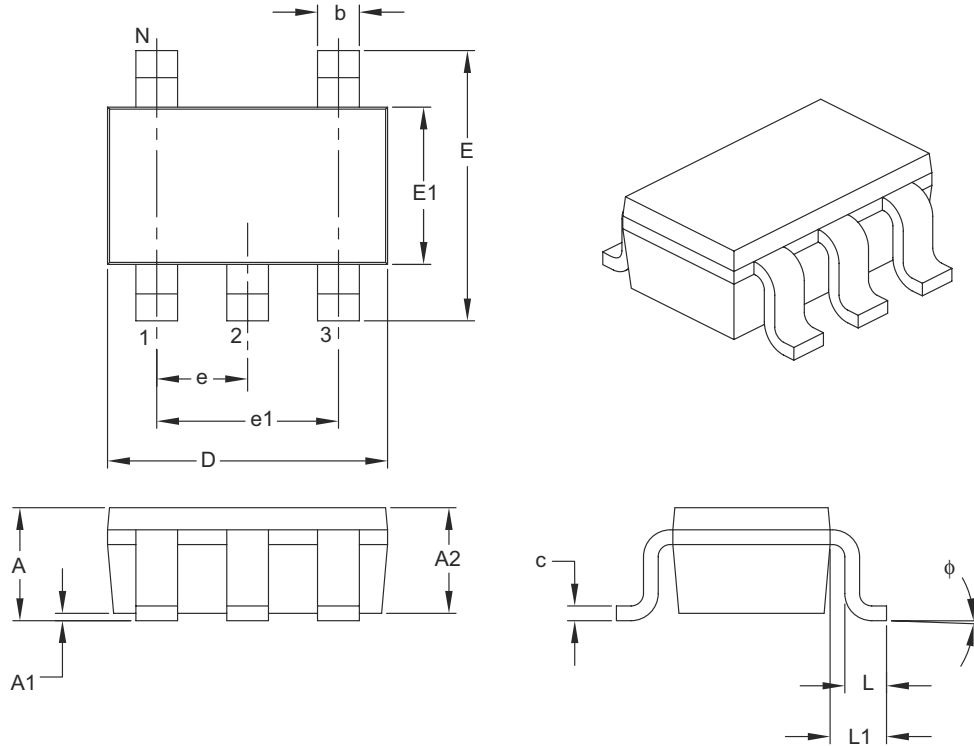
1. Dimensioning and tolerancing per ASME Y14.5M

BSC: Basic Dimension. Theoretically exact value shown without tolerances.

Microchip Technology Drawing No. C04-2061A

## 5-Lead Plastic Small Outline Transistor (OT) [SOT-23]

**Note:** For the most current package drawings, please see the Microchip Packaging Specification located at <http://www.microchip.com/packaging>



Dimension Limits	Units	MILLIMETERS		
		MIN	NOM	MAX
Number of Pins	N	5		
Lead Pitch	e	0.95 BSC		
Outside Lead Pitch	e1	1.90 BSC		
Overall Height	A	0.90	–	1.45
Molded Package Thickness	A2	0.89	–	1.30
Standoff	A1	0.00	–	0.15
Overall Width	E	2.20	–	3.20
Molded Package Width	E1	1.30	–	1.80
Overall Length	D	2.70	–	3.10
Foot Length	L	0.10	–	0.60
Footprint	L1	0.35	–	0.80
Foot Angle	$\phi$	0°	–	30°
Lead Thickness	c	0.08	–	0.26
Lead Width	b	0.20	–	0.51

**Notes:**

- Dimensions D and E1 do not include mold flash or protrusions. Mold flash or protrusions shall not exceed 0.127 mm per side.
- Dimensioning and tolerancing per ASME Y14.5M.

BSC: Basic Dimension. Theoretically exact value shown without tolerances.

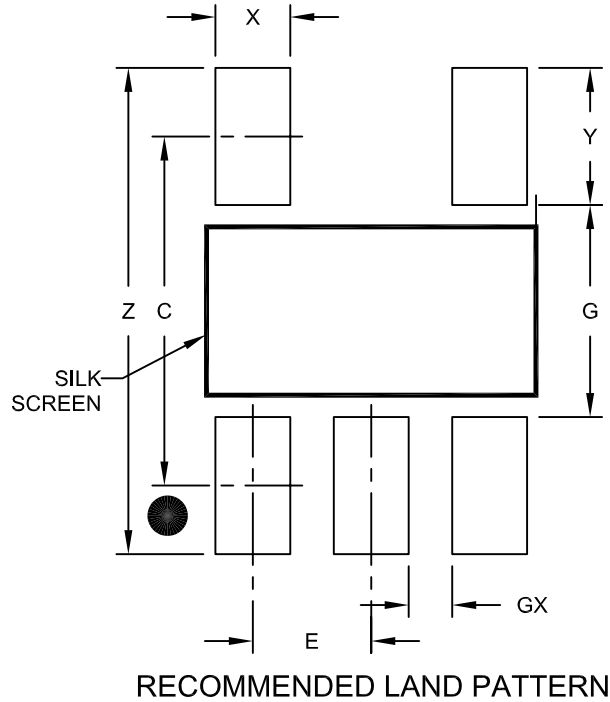
Microchip Technology Drawing C04-091B



# MCP6441/2/4

## 5-Lead Plastic Small Outline Transistor (OT) [SOT-23]

**Note:** For the most current package drawings, please see the Microchip Packaging Specification located at <http://www.microchip.com/packaging>



Dimension Limits	Units	MILLIMETERS		
		MIN	NOM	MAX
Contact Pitch	E	0.95 BSC		
Contact Pad Spacing	C		2.80	
Contact Pad Width (X5)	X			0.60
Contact Pad Length (X5)	Y			1.10
Distance Between Pads	G	1.70		
Distance Between Pads	GX	0.35		
Overall Width	Z			3.90

**Notes:**

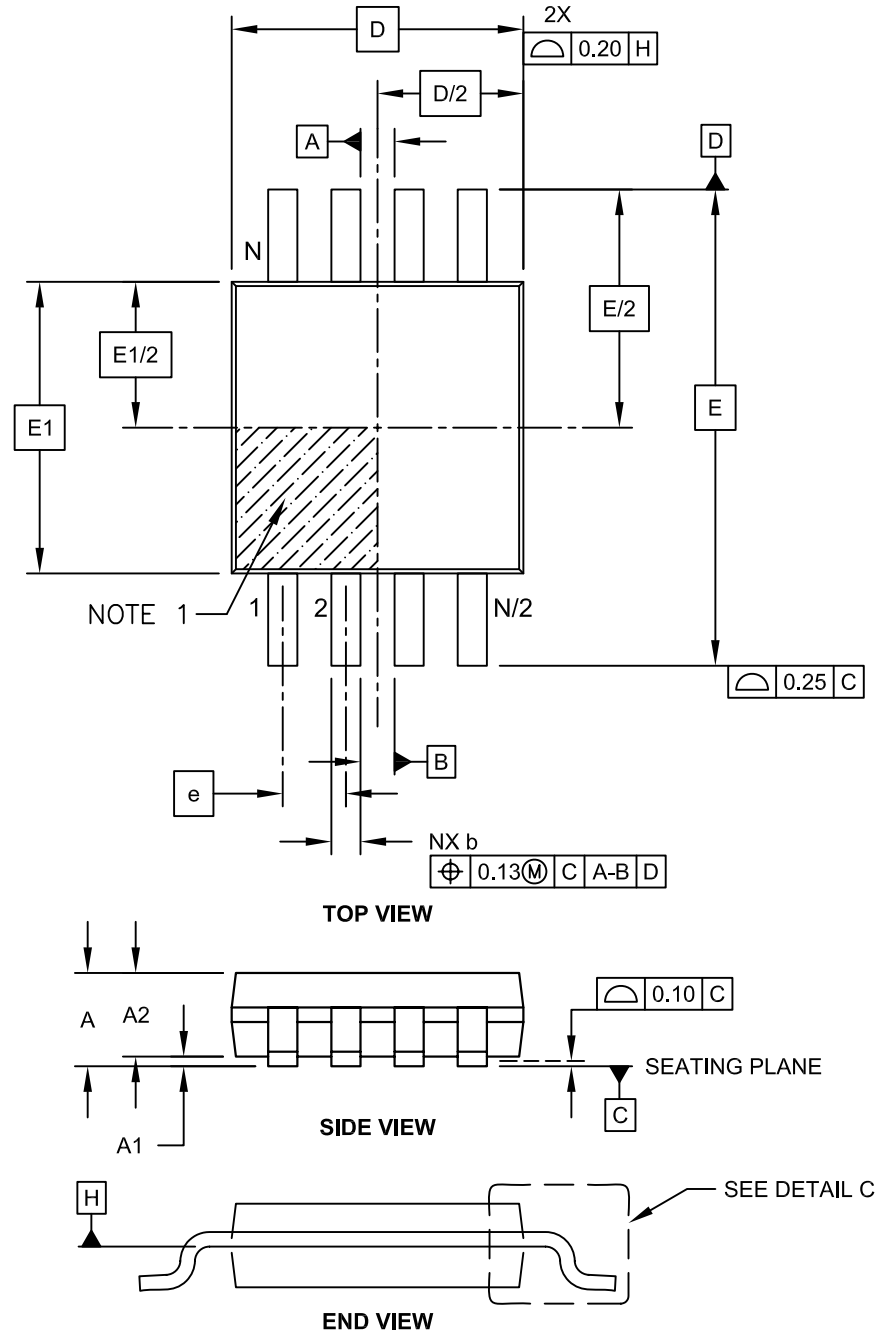
1. Dimensioning and tolerancing per ASME Y14.5M

BSC: Basic Dimension. Theoretically exact value shown without tolerances.

Microchip Technology Drawing No. C04-2091A

## 8-Lead Plastic Micro Small Outline Package (MS) [MSOP]

**Note:** For the most current package drawings, please see the Microchip Packaging Specification located at <http://www.microchip.com/packaging>



Microchip Technology Drawing C04-111C Sheet 1 of 2