



Chipsmall Limited consists of a professional team with an average of over 10 year of expertise in the distribution of electronic components. Based in Hongkong, we have already established firm and mutual-benefit business relationships with customers from,Europe,America and south Asia,supplying obsolete and hard-to-find components to meet their specific needs.

With the principle of “Quality Parts,Customers Priority,Honest Operation,and Considerate Service”,our business mainly focus on the distribution of electronic components. Line cards we deal with include Microchip,ALPS,ROHM,Xilinx,Pulse,ON,Everlight and Freescale. Main products comprise IC,Modules,Potentiometer,IC Socket,Relay,Connector.Our parts cover such applications as commercial,industrial, and automotives areas.

We are looking forward to setting up business relationship with you and hope to provide you with the best service and solution. Let us make a better world for our industry!



Contact us

Tel: +86-755-8981 8866 Fax: +86-755-8427 6832

Email & Skype: info@chipsmall.com Web: www.chipsmall.com

Address: A1208, Overseas Decoration Building, #122 Zhenhua RD., Futian, Shenzhen, China



DDR4 DIMM Temperature Sensor with EEPROM for SPD

Features

- Meets JEDEC Specification
 - MCP98244 --> JC42.4-TSE2004B1 Temperature Sensor with 4 Kbit Serial EEPROM for Serial Presence Detect (SPD)
- 1MHz, 2-wire I²C™ Interface
- Specified V_{DD} Range: 1.7V to 3.6V
- Operating Current: 100 µA (typ., EEPROM Idle)
- Available Package: TDFN-8

Temperature Sensor Features

- Temperature-to-Digital Converter (°C)
- Sensor Accuracy (Grade B):
 - **±0.2°C/±1°C (typ./max.)** → **+75°C to +95°C**
 - ±0.5°C/±2°C (typ./max.) → +40°C to +125°C
 - ±1°C/±3°C (typ./max.) → -40°C to +125°C

Serial EEPROM Features

- Operating Current:
 - Write → 250 µA (typical) for 3 ms (typical)
 - Read → 100 µA (typical)
- Reversible Software Write Protect
- Software Write Protection for each 1 Kbit Block
- Organized as two banks of 256 x 8-bit (2 Kbit x 2)

Typical Applications

- DIMM Modules for Servers, PCs, and Laptops
- Temperature Sensing for Solid State Drive (SSD)
- General Purpose Temperature Datalog

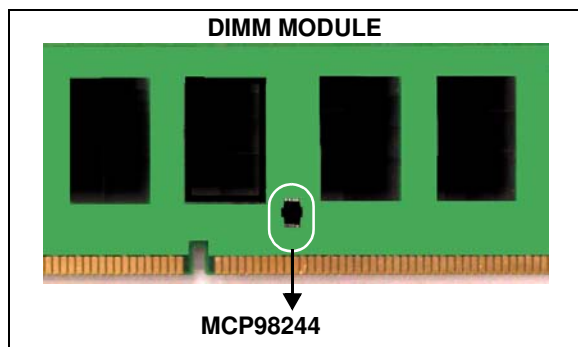

Description

Microchip Technology Inc.'s MCP98244 digital temperature sensor converts temperature from -40°C and +125°C to a digital word. This sensor meets JEDEC Specification JC42.4-TSE3000B1 Memory Module Thermal Sensor Component. It provides an accuracy of ±0.2°C/±1°C (typical/maximum) from +75°C to +95°C with an operating voltage of 1.7V to 3.6V. In addition, MCP98244 has an integrated EEPROM with two banks of 256 by 8 bit EEPROM (4k Bit) which can be used to store memory module details and vendor information.

The MCP98244 digital temperature sensor comes with user-programmable registers that provide flexibility for DIMM temperature-sensing applications. The registers allow user-selectable settings such as Shutdown or Low-Power modes and the specification of temperature Event boundaries. When the temperature changes beyond the specified Event boundary limits, the MCP98244 outputs an Alert signal at the Event pin. The user has the option of setting the temperature Event output signal polarity as either an active-low or active-high comparator output for thermostat operation, or as a temperature Event interrupt output for microprocessor-based systems.

The MCP98244 EEPROM is designed specifically for DRAM DIMMs (Dual In-line Memory Modules) Serial Presence Detect (SPD). It has four 128 Byte pages, which can be Software Write Protected individually. This allows DRAM vendor and product information to be stored and write-protected.

This sensor has an industry standard I²C Fast Mode Plus compatible 1 MHz serial interface.

Package Types

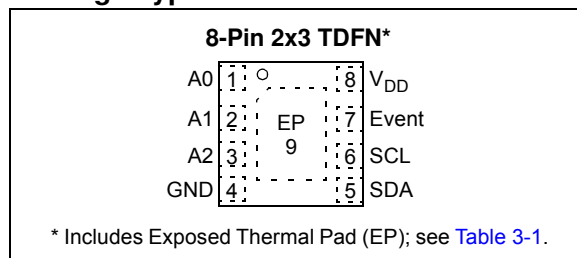

MCP98244

NOTES:

1.0 ELECTRICAL CHARACTERISTICS

Absolute Maximum Ratings †

V _{DD}	4.0V
Voltage at all Input/Output pins	GND – 0.3V to 4.0V
Pin A0	GND – 0.3V to 11V
Storage temperature	-65°C to +150°C
Ambient temp. with power applied	-40°C to +125°C
Junction Temperature (T _J)	+150°C
ESD protection on all pins (HBM:MM)	(4 kV:200V)
Latch-Up Current at each pin (25°C)	±200 mA

†**Notice:** Stresses above those listed under “Maximum ratings” may cause permanent damage to the device. This is a stress rating only and functional operation of the device at those or any other conditions above those indicated in the operational listings of this specification is not implied. Exposure to maximum rating conditions for extended periods may affect device reliability.

TEMPERATURE SENSOR DC CHARACTERISTICS

Electrical Specifications: Unless otherwise indicated, V _{DD} = 1.7V to 3.6V, GND = Ground, and T _A = -40°C to +125°C.						
Parameters	Sym	Min	Typ	Max	Unit	Conditions
Temperature Sensor Accuracy						
+75°C < T _A ≤ +95°C	T _{ACY}	-1.0	±0.2	+1.0	°C	JC42.4 - TSE2004B1 Grade B Accuracy Specification V _{DD} = 1.7V to 3.6V
+40°C < T _A ≤ +125°C		-2.0	±0.5	+2.0	°C	
-40°C < T _A ≤ +125°C		-3.0	±1	+3.0	°C	
Temperature Conversion Time						
0.5°C/bit	t _{CONV}	—	30	—	ms	15 s/sec (typical) (See Section 5.2.4)
0.25°C/bit		—	65	125	ms	
0.125°C/bit		—	130	—	ms	
0.0625°C/bit		—	260	—	ms	
Power Supply						
Specified Voltage Range	V _{DD}	1.7	—	3.6	V	
Operating Current	I _{DD_TS}	—	100	500	µA	EEPROM Inactive
Shutdown Current	I _{SHDN}	—	0.2	1	µA	EEPROM Inactive, I ² C Bus Inactive, T _A = 85°C
Power On Reset (POR)	V _{POR}	—	1.4	1.6	V	Threshold for rising and falling V _{DD}
Settling Time after POR	t _{POR}	—	—	1	ms	For warm and cold power cycles
Line Regulation	Δ°C	—	0.2	—	°C	V _{DD} = 1.7V to 3.6V
Event Output (Open-Drain output, external pull-up resistor required), see Section 5.2.3						
High-Level Current (leakage)	I _{OH}	—	—	1	µA	V _{OH} = V _{DD}
Low-Level Voltage	V _{OL}	—	—	0.4	V	I _{OL} = 3 mA (Active-Low, Pull-up Resistor)
Thermal Response, from +25°C (Air) to +125°C (oil bath)						
TDFN-8	t _{RES}	—	0.7	—	s	Time to 63% (89°C)

MCP98244

MCP98244 EEPROM DC CHARACTERISTICS

Electrical Specifications: Unless otherwise indicated, $V_{DD} = 1.7V$ to $3.6V$, GND = Ground, and $T_A = -40^{\circ}C$ to $+125^{\circ}C$.

Parameters	Sym	Min	Typ	Max	Unit	Conditions
Current, EEPROM write (for t_{WC})	$I_{DD\ EE}$	—	250	2000	μA	Sensor in Shutdown Mode
Current, EEPROM read	$I_{DD\ EE}$	—	100	500	μA	
Write Cycle time (byte/page)	t_{WC}	—	3	5	ms	
Endurance $T_A = +25^{\circ}C$	—	—	10k	—	cycles	Write Cycles, $V_{DD} = 3.3V$ (Note 1, Note 2)
EEPROM Write Temperature	EE_{WRITE}	0	—	85	$^{\circ}C$	
EEPROM Read Temperature	EE_{READ}	-40	—	125	$^{\circ}C$	For minimum read temperature, see Note 1
Write Protect Voltage						
SWP and CWP Voltage	V_{HV}	7	—	10	V	Applied at A0 pin

Note 1: Characterized but not production tested.

2: For endurance estimates in a specific application, please consult the Total Endurance™ Model, which can be obtained from Microchip's web site at www.microchip.com/TotalEndurance.

INPUT/OUTPUT PIN DC CHARACTERISTICS

Electrical Specifications: Unless otherwise indicated, $V_{DD} = 1.7V$ to $3.6V$, GND = Ground and $T_A = -40^{\circ}C$ to $+125^{\circ}C$.

Parameters	Sym	Min	Typ	Max	Units	Conditions
Serial Input/Output (SCL, SDA, A0, A1, A2)						
Input						
High-Level Voltage	V_{IH}	$0.7V_{DD}$	—	—	V	
Low-Level Voltage	V_{IL}	—	—	$0.3V_{DD}$	V	
Input Current	I_{IN}	—	—	± 5	μA	SDA and SCL only
Input Impedance (A0, A1, A2)	Z_{IN}	—	1	—	$M\Omega$	$V_{IN} > V_{IH}$
Input Impedance (A0, A1, A2)	Z_{IN}	—	200	—	$k\Omega$	$V_{IN} < V_{IL}$
Output (SDA only)						
Low-Level Voltage	V_{OL}	—	—	0.4	V	$I_{OL} = 3\text{ mA}$
High-Level Current (leakage)	I_{OH}	—	—	1	μA	$V_{OH} = V_{DD}$
Low-Level Current	I_{OL}	20	—	—	mA	$V_{OL} = 0.4V; V_{DD} \geq 2.2V$
		6	—	—	mA	$V_{OL} = 0.6V$
Capacitance	C_{IN}	—	5	—	pF	
SDA and SCL Inputs						
Hysteresis	V_{HYST}	—	$0.05V_{DD}$	—	V	
Spike Suppression	T_{SP}	—	—	50	ns	

TEMPERATURE CHARACTERISTICS

Electrical Specifications: Unless otherwise indicated, $V_{DD} = 1.7V$ to $3.6V$, GND = Ground, and $T_A = -40^{\circ}C$ to $+125^{\circ}C$.

Parameters	Sym	Min	Typ	Max	Units	Conditions
Temperature Ranges						
Specified Temperature Range	T_A	-40	—	+125	$^{\circ}C$	Note 1
Operating Temperature Range	T_A	-40	—	+125	$^{\circ}C$	
Storage Temperature Range	T_A	-65	—	+150	$^{\circ}C$	
Thermal Package Resistances						
Thermal Resistance, 8L-TDFN	θ_{JA}	—	52.5	—	$^{\circ}C/W$	

Note 1: Operation in this range must not cause T_J to exceed Maximum Junction Temperature ($+150^{\circ}C$).

SERIAL INTERFACE TIMING SPECIFICATIONS

Electrical Specifications: Unless otherwise indicated, GND = Ground, $T_A = -40^\circ\text{C}$ to $+125^\circ\text{C}$, and $C_L = 80\text{ pF}$ (Note 1).

		$V_{DD} = 1.7\text{V to }3.6\text{V}$		$V_{DD} = 2.2\text{V to }3.6\text{V}$				Units
		100 kHz		400 kHz		1000 KHz		
Parameters	Sym	Min	Max	Min	Max	Min	Max	
2-Wire I²C Interface								
Serial port frequency (Note 2, 4)	f_{SCL}	10	100	10	400	10	1000	kHz
Low Clock (Note 2)	t_{LOW}	4700	—	1300	—	500	—	ns
High Clock	t_{HIGH}	4000	—	600	—	260	—	ns
Rise time (Note 5)	t_R	—	1000	20	300	—	120	ns
Fall time (Note 5)	t_F	20	300	20	300	—	120	ns
Data in Setup time (Note 3)	$t_{SU:DAT}$	250	—	100	—	50	—	ns
Data in Hold time (Note 6)	$t_{HD:DI}$	0	—	0	—	0	—	ns
Data out Hold time (Note 4)	$t_{HD:DO}$	200	900	200	900	0	350	ns
Start Condition Setup time	$t_{SU:STA}$	4700	—	600	—	260	—	ns
Start Condition Hold time	$t_{HD:STA}$	4000	—	600	—	260	—	ns
Stop Condition Setup time	$t_{SU:STO}$	4000	—	600	—	260	—	ns
Bus Idle/Free	t_{B-FREE}	4700	—	1300	—	500	—	ns
Time out	t_{OUT}	25	35	25	35	25	35	ms
Bus Capacitive load	C_b	—	—	—	400	—	100	pf

Note 1: All values referred to $V_{IL\text{ MAX}}$ and $V_{IH\text{ MIN}}$ levels.

- If $t_{LOW} > t_{OUT}$, the temperature sensor I²C interface will time out. A Repeat Start command is required for communication.
- This device can be used in a Standard-mode I²C-bus system, but the requirement $t_{SU:DAT} \geq 250\text{ ns}$ must be met. This device does not stretch SCL Low period. It outputs the next data bit to the SDA line within $t_R\text{ MAX} + t_{SU:DAT\text{ MIN}} = 1000\text{ ns} + 250\text{ ns} = 1250\text{ ns}$ (according to the Standard-mode I²C-bus specification) before the SCL line is released.
- As a transmitter, the device provides internal minimum delay time $t_{HD:DAT\text{ MIN}}$ to bridge the undefined region (min. 200 ns) of the falling edge of SCL $t_F\text{ MAX}$ to avoid unintended generation of Start or Stop conditions.
- Characterized but not production tested.
- As a receiver, SDA should not be sampled at the falling edge of SCL. SDA can transition $t_{HD:DI}$ 0 ns after SCL toggles Low.

TIMING DIAGRAM

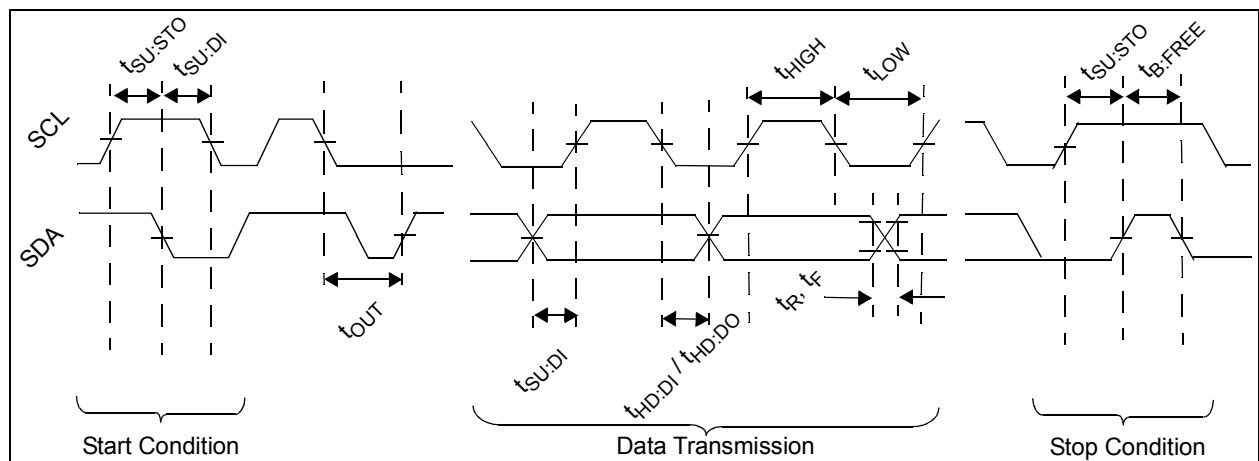

MCP98244

2.0 TYPICAL PERFORMANCE CURVES

Note: The graphs and tables provided following this note are a statistical summary based on a limited number of samples and are provided for informational purposes only. The performance characteristics listed herein are not tested or guaranteed. In some graphs or tables, the data presented may be outside the specified operating range (e.g., outside specified power supply range) and therefore outside the warranted range.

Note: Unless otherwise indicated, $V_{DD} = 1.7V$ to $3.6V$, GND = Ground, SDA/SCL pulled-up to V_{DD} , and $T_A = -40^{\circ}C$ to $+125^{\circ}C$.

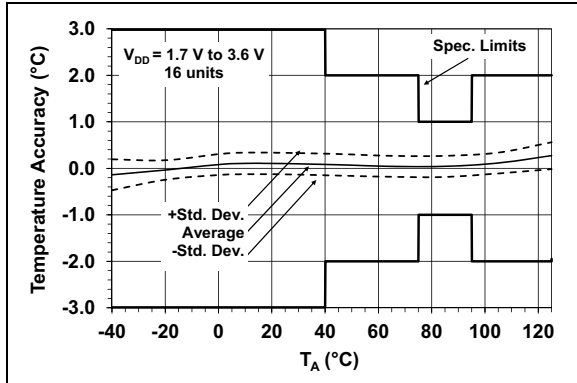

FIGURE 2-1: Temperature Accuracy.

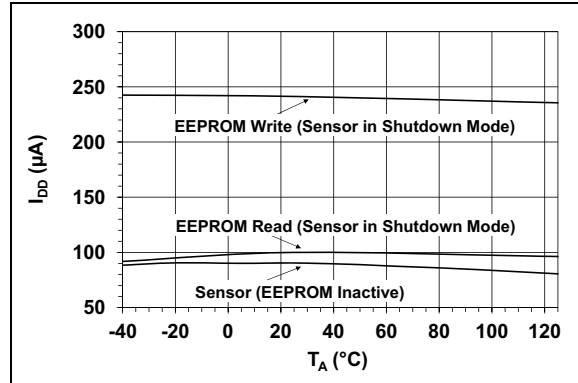

FIGURE 2-4: Supply Current Vs. Temperature.

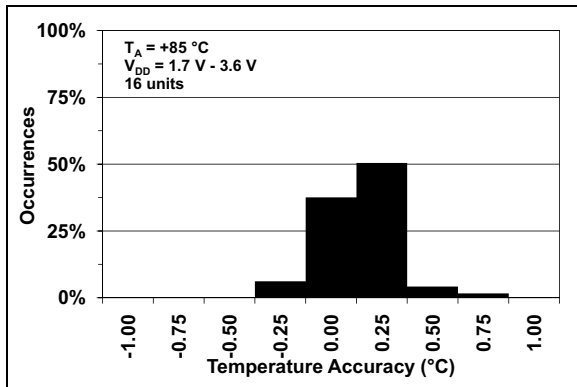

FIGURE 2-2: Temperature Accuracy Histogram, $T_A = +85^{\circ}C$.

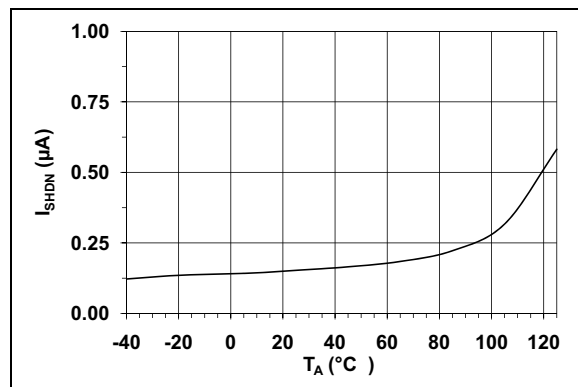

FIGURE 2-5: Shutdown Current Vs. Temperature.

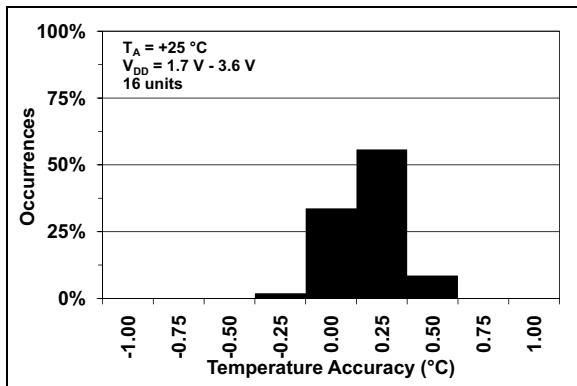

FIGURE 2-3: Temperature Accuracy Histogram, $T_A = +105^{\circ}C$.

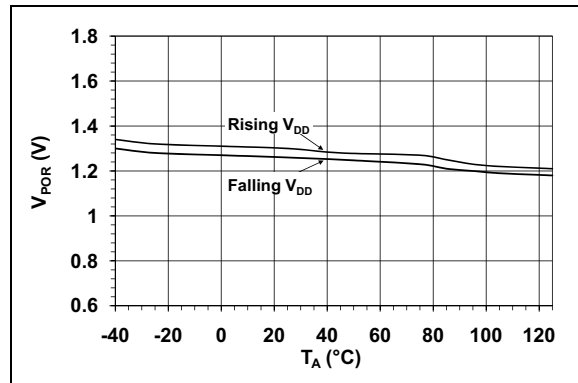

FIGURE 2-6: Power On Reset Threshold Voltage Vs. Temperature.

Note: Unless otherwise indicated, $V_{DD} = 1.7\text{V to }3.6\text{V}$, GND = Ground, SDA/SCL pulled-up to V_{DD} , and $T_A = -40^\circ\text{C to }+125^\circ\text{C}$.

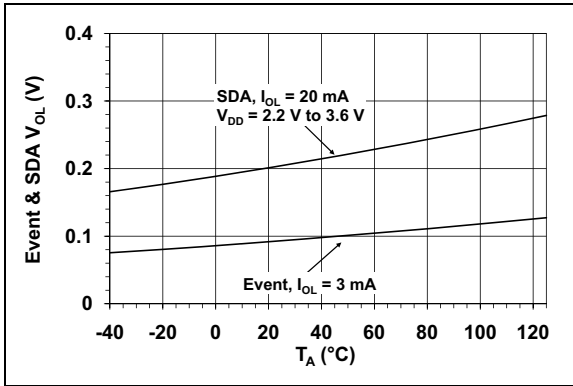

FIGURE 2-7: Event Output and SDA V_{OL} Vs. Temperature.

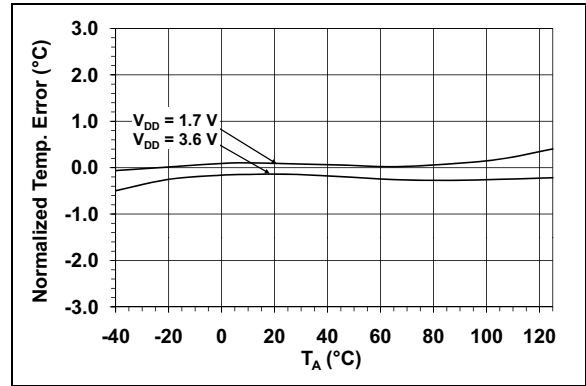

FIGURE 2-10: Line Regulation: Change in Temperature Accuracy Vs. Change in V_{DD} .

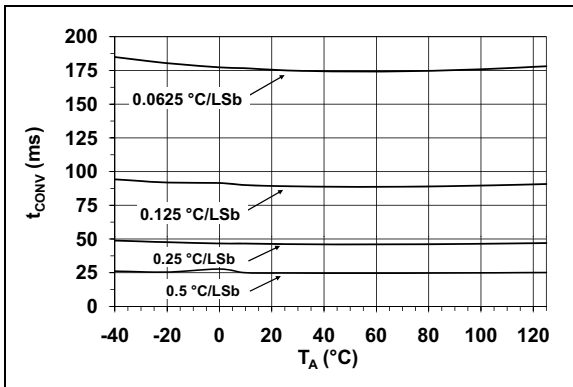

FIGURE 2-8: Temperature Conversion Rate Vs. Temperature.

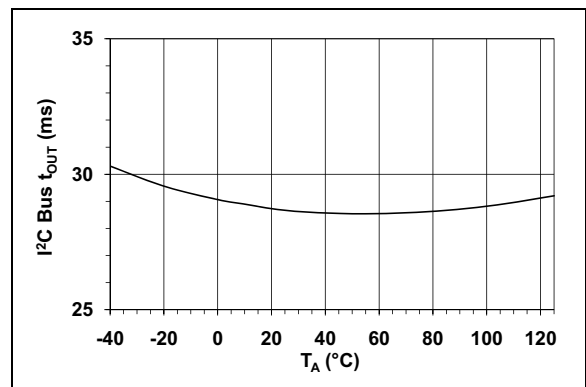

FIGURE 2-11: I^2C Protocol Time-out Vs. Temperature.

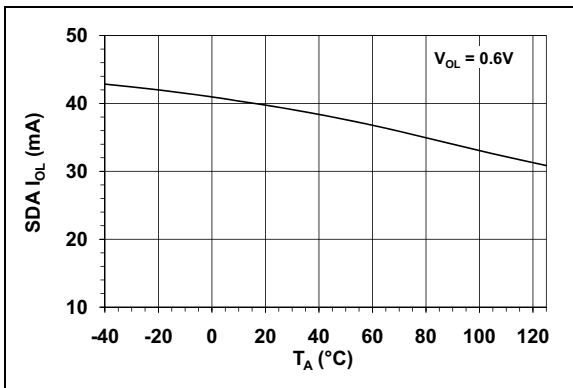

FIGURE 2-9: SDA I_{OL} Vs. Temperature.

MCP98244

3.0 PIN DESCRIPTION

The descriptions of the pins are listed in [Table 3-1](#).

TABLE 3-1: PIN FUNCTION TABLES

MCP98244 TDFN	Symbol	Description
1	A0	Slave Address and EEPROM Software Write Protect High Voltage Input (V_{HV})
2	A1	Slave Address
3	A2	Slave Address
4	GND	Ground
5	SDA	Serial Data Line
6	SCL	Serial Clock Line
7	Event	Temperature Alert Output
8	V_{DD}	Power Pin
9	EP	Exposed Thermal Pad (EP); can be connected to GND.

3.1 Address Pins (A0, A1, A2)

These pins are device address input pins.

The address pins correspond to the Least Significant bits (LSb) of address bits. The Most Significant bits (MSb) are (A6, A5, A4, A3). This is shown in [Table 3-2](#).

TABLE 3-2: MCP98244 ADDRESS BYTE

Device	Address Code				Slave Address		
	A6	A5	A4	A3	A2	A1	A0
Sensor	0	0	1	1	X ¹	X ¹	X ¹
EEPROM	1	0	1	0			
EEPROM Write Protect	0	1	1	0	— ²	— ²	— ²

Note 1: User-selectable address is shown by X, where X is 1 or 0 for V_{DD} and GND, respectively.

2: The address pins are ignored for all Write Protect commands.

The A0 Address pin is a multi-function pin. This input pin is also used for high voltage input V_{HV} to enable the EEPROM Software Write Protect feature, for more information see [Section 5.3.3 “Bank or page selection for EEPROM Read/write operation”](#).

All address pin have an internal pull-down resistors.

3.2 Ground Pin (GND)

The GND pin is the system ground pin.

3.3 Serial Data Line (SDA)

SDA is a bidirectional input/output pin, used to serially transmit data to/from the host controller. This pin requires a pull-up resistor. (See [Section 4.0 “Serial Communication”](#)).

3.4 Serial Clock Line (SCL)

The SCL is a clock input pin. All communication timing is relative to the signal on this pin. The clock is generated by the host or master controller on the bus. (See [Section 4.0 “Serial Communication”](#)).

3.5 Temperature Alert, Open-Drain Output (Event)

The MCP98244 temperature Event output pin is an open-drain output. The device outputs a signal when the ambient temperature goes beyond the user-programmed temperature limit. (see [Section 5.2.3 “Event Output Configuration”](#)).

3.6 Power Pin (V_{DD})

V_{DD} is the power pin. The operating voltage range, as specified in the DC electrical specification table, is applied on this pin.

3.7 Exposed Thermal Pad (EP)

There is an internal electrical connection between the Exposed Thermal Pad (EP) and the GND pin; they can be connected to the same potential on the Printed Circuit Board (PCB). This provides better thermal conduction from the PCB to the die.

4.0 SERIAL COMMUNICATION

4.1 2-Wire Standard Mode I²C™ Protocol-Compatible Interface

The MCP98244 serial clock input (SCL) and the bidirectional serial data line (SDA) form a 2-wire bidirectional Standard mode I²C-compatible communication port (refer to the [Input/Output Pin DC Characteristics](#) Table and [Serial Interface Timing Specifications](#) Table).

The following bus protocol has been defined:

TABLE 4-1: MCP98244 SERIAL BUS PROTOCOL DESCRIPTIONS

Term	Description
Master	The device that controls the serial bus, typically a microcontroller.
Slave	The device addressed by the master, such as the MCP98244 .
Transmitter	Device sending data to the bus.
Receiver	Device receiving data from the bus.
START	A unique signal from master to initiate serial interface with a slave.
STOP	A unique signal from the master to terminate serial interface from a slave.
Read/Write	A read or write to the MCP98244 registers.
ACK	A receiver Acknowledges (ACK) the reception of each byte by polling the bus.
NAK	A receiver Not-Acknowledges (NAK) or releases the bus to show End-of-Data (EOD).
Busy	Communication is not possible because the bus is in use.
Not Busy	The bus is in the idle state, both SDA and SCL remain high.
Data Valid	SDA must remain stable before SCL becomes high in order for a data bit to be considered valid. During normal data transfers, SDA only changes state while SCL is low.

4.1.1 DATA TRANSFER

Data transfers are initiated by a Start condition (START), followed by a 7-bit device address and a read/write bit. An Acknowledge (ACK) from the slave confirms the reception of each byte. Each access must be terminated by a Stop condition (STOP).

Repeated communication is initiated after t_{B-FREE} .

This device does not support sequential register read/write. Each register needs to be addressed using the Register Pointer.

This device supports the Receive Protocol. The register can be specified using the pointer for the initial read. Each repeated read or receive begins with a Start condition and address byte. The MCP98244 retains the previously selected register. Therefore, they output data from the previously-specified register (repeated pointer specification is not necessary).

4.1.2 MASTER/SLAVE

The bus is controlled by a master device (typically a microcontroller) that controls the bus access and generates the Start and Stop conditions. The MCP98244 is a slave device and does not control other devices in the bus. Both master and slave devices can operate as either transmitter or receiver. However, the master device determines which mode is activated.

4.1.3 START/STOP CONDITION

A high-to-low transition of the SDA line (while SCL is high) is the Start condition. All data transfers must be preceded by a Start condition from the master. A low-to-high transition of the SDA line (while SCL is high) signifies a Stop condition.

If a Start or Stop condition is introduced during data transmission, the MCP98244 releases the bus. All data transfers are ended by a Stop condition from the master.

4.1.4 ADDRESS BYTE

Following the Start condition, the host must transmit an 8-bit address byte to the MCP98244. The address for the MCP98244 Temperature Sensor is '0011, A2, A1, A0' in binary, where the A2, A1 and A0 bits are set externally by connecting the corresponding pins to V_{DD} '1' or GND '0'. The 7-bit address transmitted in the serial bit stream must match the selected address for the MCP98244 to respond with an ACK. Bit 8 in the address byte is a read/write bit. Setting this bit to '1' commands a read operation, while '0' commands a write operation (see [Figure 4-1](#)).

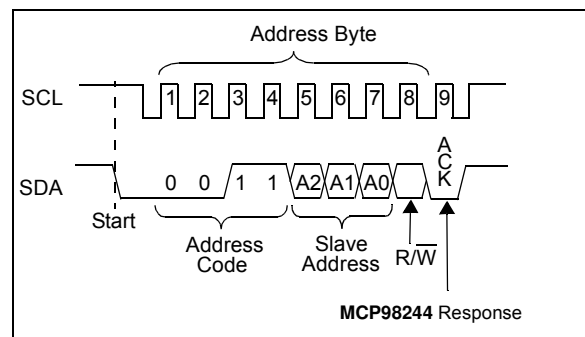

FIGURE 4-1: Device Addressing.

4.1.5 DATA VALID

After the Start condition, each bit of data in transmission needs to be settled for a time specified by $t_{SU-DATA}$ before SCL toggles from low-to-high (see [Serial Interface Timing Specifications](#) table).

MCP98244

4.1.6 ACKNOWLEDGE (ACK/NAK)

Each receiving device, when addressed, is obliged to generate an ACK bit after the reception of each byte. The master device must generate an extra clock pulse for ACK to be recognized.

The acknowledging device pulls down the SDA line for $t_{\text{SU-DATA}}$ before the low-to-high transition of SCL from the master. SDA also needs to remain pulled down for $t_{\text{H-DATA}}$ after a high-to-low transition of SCL.

During read, the master must signal an End-of-Data (EOD) to the slave by not generating an ACK bit (NAK) once the last bit has been clocked out of the slave. In this case, the slave will leave the data line released to enable the master to generate the Stop condition.

4.1.7 TIME OUT (T_{OUT})

If the SCL stays low or high for time specified by t_{OUT} , the MCP98244 resets the serial interface. This dictates the minimum clock speed as indicated in the specification.

5.0 FUNCTIONAL DESCRIPTION

The MCP98244 temperature sensors consists of a band-gap type temperature sensor, a Delta-Sigma Analog-to-Digital Converter ($\Sigma\Delta$ ADC), user-program-

mable registers and a 2-wire I²C protocol compatible serial interface. Figure 5-1 shows a block diagram of the register structure.

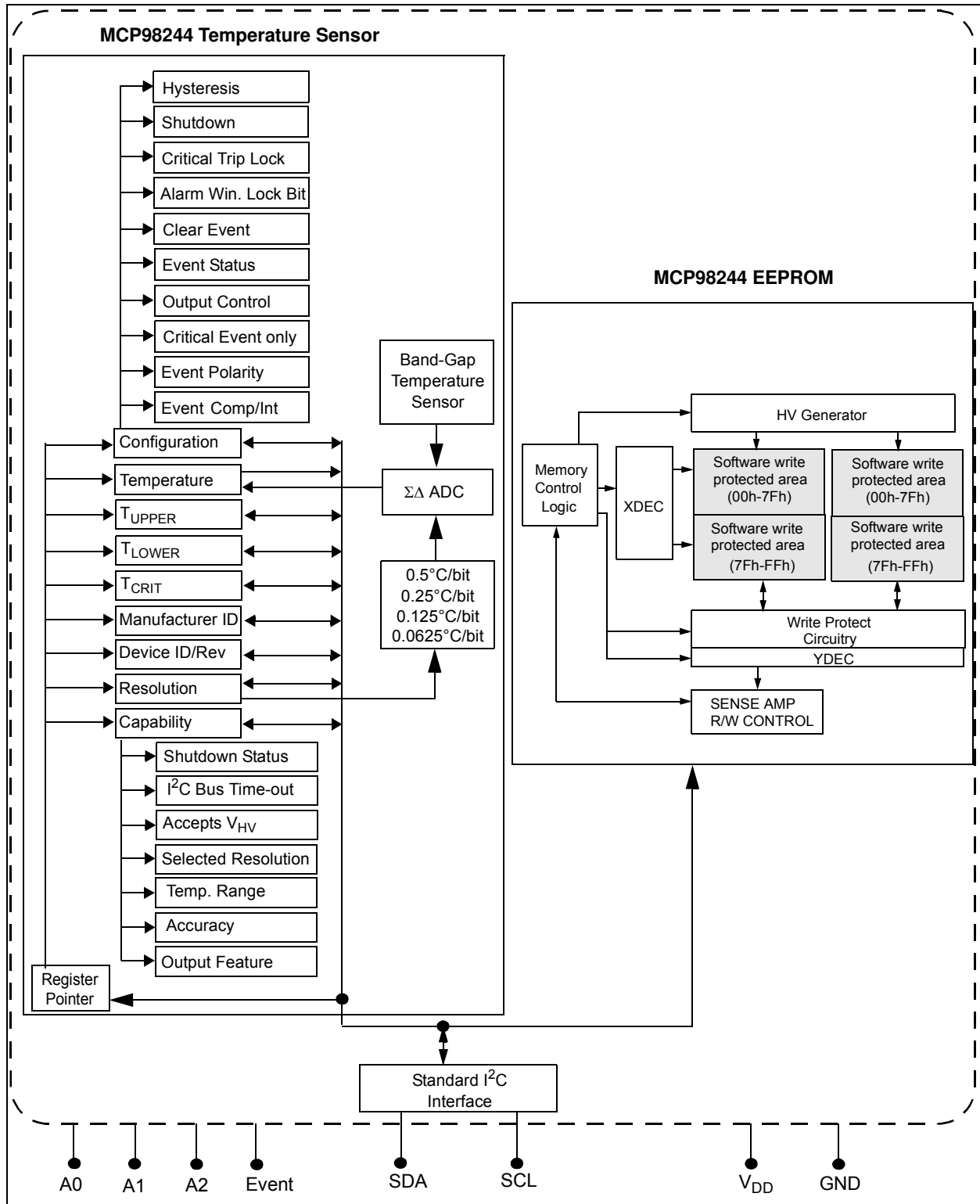

FIGURE 5-1: Functional Block Diagram.

MCP98244

5.1 Registers

The MCP98244 device has several registers that are user-accessible. These registers include the Capability register, Configuration register, Event Temperature Upper-Boundary and Lower-Boundary Trip registers, Critical Temperature Trip register, Temperature register, Manufacturer Identification register and Device Identification register.

The Temperature register is read-only, used to access the ambient temperature data. The data is loaded in parallel to this register after t_{CONV} . The Event Temperature Upper-Boundary and Lower-Boundary Trip registers are read/writes. If the ambient temperature drifts beyond the user-specified limits, the MCP98244 device outputs a signal using the Event pin (refer to [Section 5.2.3 “Event Output Configuration”](#)). In addition, the Critical Temperature Trip register is used to provide an additional critical temperature limit.

The Capability register is used to provide bits describing the MCP98244’s capability in measurement resolution, measurement range and device accuracy. The device Configuration register provides access to configure the MCP98244’s various features. These registers are described in further detail in the following sections.

The registers are accessed by sending a Register Pointer to the MCP98244 using the serial interface. This is an 8-bit write-only pointer, and [Register 5-1](#) describes the pointer assignment.

REGISTER 5-1: REGISTER POINTER (WRITE ONLY)

W-0	W-0	W-0	W-0	W-0	W-0	W-0	W-0
—	—	—	—	Pointer Bits			
bit 7							bit 0

Legend:			
R = Readable bit	W = Writable bit	U = Unimplemented bit, read as ‘0’	
-n = Value at POR	‘1’ = Bit is set	‘0’ = Bit is cleared	x = Bit is unknown

- bit 7-4 **Writable Bits:** Write ‘0’
- bit 3-0 **Pointer Bits:**
- 0000 = Capability register
- 0001 = Configuration register (CONFIG)
- 0010 = Event Temperature Upper-Boundary Trip register (T_{UPPER})
- 0011 = Event Temperature Lower-Boundary Trip register (T_{LOWER})
- 0100 = Critical Temperature Trip register (T_{CRIT})
- 0101 = Temperature register (T_A)
- 0110 = Manufacturer ID register
- 0111 = Device ID/Revision register
- 1000 = TSE2004av Device ID and Vendor Silicon Revision Register
- 1001 = Resolution register
- 1XXX = Unused (The device will not acknowledge commands to other pointer locations.)

**TABLE 5-1: BIT ASSIGNMENT SUMMARY FOR ALL TEMPERATURE SENSOR REGISTERS
(SEE SECTION 5.4)**

Register Pointer (Hex)	MSB/LSB	Bit Assignment							
		7	6	5	4	3	2	1	0
0x00	MSB	0	0	0	0	0	0	0	0
	LSB	SHDN Status	t _{OUT} Range	V _{HV}	Resolution		Range	Accuracy	Event
0x01	MSB	0	0	0	0	0	Hysteresis		SHDN
	LSB	Crt Loc	Win Loc	Int Clr	Evt Stat	Evt Cnt	Evt Sel	Evt Pol	Evt Mod
0x02	MSB	0	0	0	SIGN	2 ⁷ °C	2 ⁶ °C	2 ⁵ °C	2 ⁴ °C
	LSB	2 ³ °C	2 ² °C	2 ¹ °C	2 ⁰ °C	2 ⁻¹ °C	2 ⁻² °C	0	0
0x03	MSB	0	0	0	SIGN	2 ⁷ °C	2 ⁶ °C	2 ⁵ °C	2 ⁴ °C
	LSB	2 ³ °C	2 ² °C	2 ¹ °C	2 ⁰ °C	2 ⁻¹ °C	2 ⁻² °C	0	0
0x04	MSB	0	0	0	SIGN	2 ⁷ °C	2 ⁶ °C	2 ⁵ °C	2 ⁴ °C
	LSB	2 ³ °C	2 ² °C	2 ¹ °C	2 ⁰ °C	2 ⁻¹ °C	2 ⁻² °C	0	0
0x05	MSB	T _A ≥ T _{CRIT}	T _A > T _{UPPER}	T _A < T _{LOWER}	SIGN	2 ⁷ °C	2 ⁶ °C	2 ⁵ °C	2 ⁴ °C
	LSB	2 ³ °C	2 ² °C	2 ¹ °C	2 ⁰ °C	2 ⁻¹ °C	2 ⁻² °C	2 ⁻³ °C	2 ⁻⁴ °C
0x06	MSB	0	0	0	0	0	0	0	0
	LSB	0	1	0	1	0	1	0	0
0x07	MSB	0	0	1	0	0	0	1	0
	LSB	0	0	0	0	0	0	0	1
0x08	MSB	0	0	1	0	0	0	1	0
	LSB	0	0	0	0	0	0	0	1
0x09	MSB	0	0	0	0	0	0	0	0
	LSB	0	0	0	0	0	0	Resolution	

MCP98244

5.1.1 CAPABILITY REGISTER

This is a read-only register used to identify the temperature sensor capability. The device capability bit assignments are specified by TSE2004av, and this device is factory configured to meet the default conditions as described in [Register 5-2](#) (these values can not be changed).

For example, the MCP98244 device is capable of providing temperature at 0.25°C resolution, measuring temperature below and above 0°C, providing ±1°C and ±2°C accuracy over the active and monitor temperature ranges (respectively) and providing user-programmable temperature event boundary trip limits.

These functions are described in further detail in the following sections.

REGISTER 5-2: CAPABILITY REGISTER (READ-ONLY) → ADDRESS '0000 0000'b

U-0	U-0	U-0	U-0	U-0	U-0	U-0	U-0
—	—	—	—	—	—	—	—
bit 15							bit 8

R-1	R-1	R-1	R-0	R-1	R-1	R-1	R-1
SHDN Status	t _{OUT} Range	V _{HV}	Resolution	Meas. Range	Accuracy	Temp Alarm	
bit 7							bit 0

Legend:

R = Readable bit

W = Writable bit

U = Unimplemented bit, read as '0'

-n = Value at POR

'1' = Bit is set

'0' = Bit is cleared

x = Bit is unknown

bit 15-8 **Unimplemented:** Read as '0'

bit 7 **Event output status during Shutdown (SHDN Status):**

0 = Event output remains in previous state. If the output asserts before shutdown command, it remains asserted during shutdown.

1 = Event output deasserts during shutdown. After shutdown, it takes t_{CONV} to re-assert the Event output (power-up default)

bit 6 **I²C Bus time-out (t_{OUT} Range):**

0 = Bus time-out range is 10 ms to 60 ms

1 = Bus time-out range is 25 ms to 35 ms (power-up default)

bit 5 **High Voltage Input**

0 = Pin A0 does not accept High Voltage

1 = Pin A0 accepts High Voltage for the EEPROM Write Protect feature (power-up default)

bit 4-3 **Resolution:**

00 = 0.5°C

01 = 0.25°C (power up default)

10 = 0.125°C

11 = 0.0625°C

These bits reflect the selected resolution (see [Section 5.2.4 "Temperature Resolution"](#))

bit 2 **Temperature Measurement Range (Meas. Range):**

0 = T_A = 0 (decimal) for temperature below 0°C

1 = The part can measure temperature below 0°C (power-up default)

REGISTER 5-2: CAPABILITY REGISTER (READ-ONLY) → ADDRESS '0000 0000'b (CONTINUED)

- bit 1 **Accuracy:**
 0 = Accuracy → ±2°C from +75°C to +95°C (Active Range) and ±3°C from +40°C to +125°C (Monitor Range)
 1 = Accuracy → ±1°C from +75°C to +95°C (Active Range) and ±2°C from +40°C to +125°C (Monitor Range)
- bit 0 **Temperature Alarm:**
 0 = No defined function (This bit will never be cleared or set to '0.')
- 1 = The part has temperature boundary trip limits (T_{UPPER}/T_{LOWER}/T_{CRIT} registers) and a temperature event output (JC 42.4 required feature)

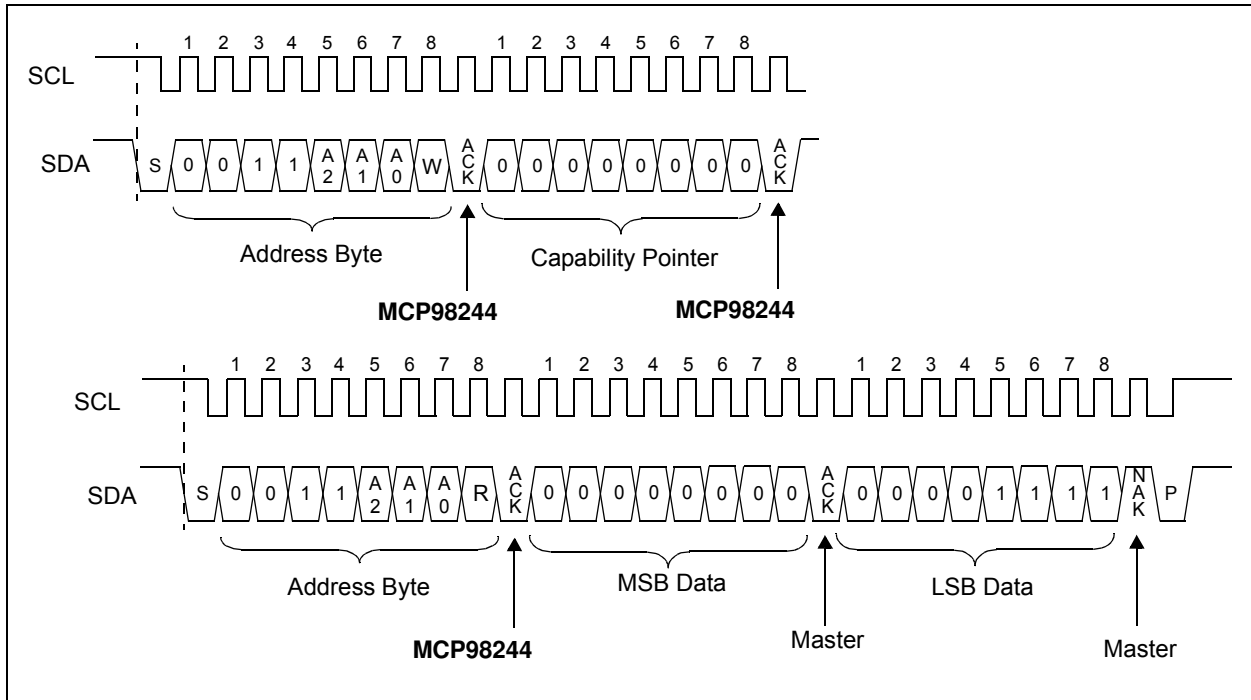

FIGURE 5-2: Timing Diagram for Reading the Capability Register (See [Section 4.0 “Serial Communication”](#)).

MCP98244

5.1.2 SENSOR CONFIGURATION REGISTER (CONFIG)

The MCP98244 device has a 16-bit Configuration register (CONFIG) that allows the user to set various functions for a robust temperature monitoring system. Bits 10 thru 0 are used to select Event output boundary hysteresis, device Shutdown or Low-Power mode, temperature boundary and critical temperature lock, or temperature Event output enable/disable. In addition, the user can select the Event output condition (output set for T_{UPPER} and T_{LOWER} temperature boundary or T_{CRIT} only), read Event output status and set Event output polarity and mode (Comparator Output or Interrupt Output mode).

The temperature hysteresis bits 10 and 9 can be used to prevent output chatter when the ambient temperature gradually changes beyond the user-specified temperature boundary (see [Section 5.2.2 “Temperature Hysteresis \(T_{HYST}\)”](#)). The Continuous

Conversion or Shutdown mode is selected using bit 8. In Shutdown mode, the band gap temperature sensor circuit stops converting temperature and the Ambient Temperature register (T_A) holds the previous successfully converted temperature data (see [Section 5.2.1 “Shutdown Mode”](#)). Bits 7 and 6 are used to lock the user-specified boundaries T_{UPPER}, T_{LOWER} and T_{CRIT} to prevent an accidental rewrite. Bits 5 thru 0 are used to configure the temperature Event output pin. All functions are described in [Register 5-3](#) (see [Section 5.2.3 “Event Output Configuration”](#)).

REGISTER 5-3: CONFIGURATION REGISTER (CONFIG) → ADDRESS '0000 0001'b

U-0	U-0	U-0	U-0	U-0	R/W-0	R/W-0	R/W-0
—	—	—	—	—	T _{HYST}		SHDN
bit 15							bit 8

R/W-0	R/W-0	R/W-0	R-0	R/W-0	R/W-0	R/W-0	R/W-0
Crit. Lock	Win. Lock	Int. Clear	Event Stat.	Event Cnt.	Event Sel.	Event Pol.	Event Mod.
bit 7							bit 0

Legend:			
R = Readable bit	W = Writable bit	U = Unimplemented bit, read as '0'	
-n = Value at POR	'1' = Bit is set	'0' = Bit is cleared	x = Bit is unknown

bit 15-11 **Unimplemented:** Read as '0'

bit 10-9 **T_{UPPER} and T_{LOWER} Limit Hysteresis (T_{HYST}):**

- 00 = 0°C (power-up default)
- 01 = 1.5°C
- 10 = 3.0°C
- 11 = 6.0°C

(Refer to [Section 5.2.3 “Event Output Configuration”](#))

This bit can not be altered when either of the lock bits are set (bit 6 and bit 7).

This bit can be programmed in Shutdown mode.

bit 8 **Shutdown Mode (SHDN):**

- 0 = Continuous Conversion (power-up default)
- 1 = Shutdown (Low-Power mode)

In shutdown, all power-consuming activities are disabled, though all registers can be written to or read. Event output will deassert.

This bit cannot be set '1' when either of the lock bits is set (bit 6 and bit 7). However, it can be cleared '0' for Continuous Conversion while locked (Refer to [Section 5.2.1 “Shutdown Mode”](#)).

**REGISTER 5-3: CONFIGURATION REGISTER (CONFIG) → ADDRESS '0000 0001'b
(CONTINUED)**

bit 7	<p>T_{CRIT} Lock Bit (Crit. Lock): 0 = Unlocked. T_{CRIT} register can be written (power-up default) 1 = Locked. T_{CRIT} register can not be written</p> <p>When enabled, this bit remains set '1' or locked until cleared by internal reset (Section 5.4 “Summary of Power-On Default”). This bit does not require a double-write.</p> <p>This bit can be programmed in Shutdown mode.</p>
bit 6	<p>T_{UPPER} and T_{LOWER} Window Lock Bit (Win. Lock): 0 = Unlocked. T_{UPPER} and T_{LOWER} registers can be written (power-up default) 1 = Locked. T_{UPPER} and T_{LOWER} registers can not be written</p> <p>When enabled, this bit remains set '1' or locked until cleared by power-on Respell (Section 5.4 “Summary of Power-On Default”). This bit does not require a double-write.</p> <p>This bit can be programmed in Shutdown mode.</p>
bit 5	<p>Interrupt Clear (Int. Clear) Bit: 0 = No effect (power-up default) 1 = Clear interrupt output. When read this bit returns '0'</p> <p>This bit clears the Interrupt flag which deasserts Event output. In shutdown mode, the Event output is always deasserted. Therefore, setting this bit in Shutdown mode clears the interrupt after the device returns to normal operation.</p>
bit 4	<p>Event Output Status (Event Stat.) Bit: 0 = Event output is not asserted by the device (power-up default) 1 = Event output is asserted as a comparator/Interrupt or critical temperature output</p> <p>In shutdown mode this bit will clear because Event output is always deasserted in Shutdown mode.</p>
bit 3	<p>Event Output Control (Event Cnt.) Bit: 0 = Event output Disabled (power-up default) 1 = Event output Enabled</p> <p>This bit can not be altered when either of the lock bits is set (bit 6 and bit 7).</p> <p>This bit can be programmed in Shutdown mode, but Event output will remain deasserted.</p>
bit 2	<p>Event Output Select (Event Sel.) Bit: 0 = Event output for T_{UPPER}, T_{LOWER} and T_{CRIT} (power-up default) 1 = T_A ≥ T_{CRIT} only. (T_{UPPER} and T_{LOWER} temperature boundaries are disabled.)</p> <p>When the Alarm Window Lock bit is set, this bit cannot be altered until unlocked (bit 6).</p> <p>This bit can be programmed in Shutdown mode, but Event output will remain deasserted.</p>
bit 1	<p>Event Output Polarity (Event Pol.) Bit: 0 = Active low (power-up default. Pull-up resistor required) 1 = Active-high</p> <p>This bit cannot be altered when either of the lock bits is set (bit 6 and bit 7).</p> <p>This bit can be programmed in Shutdown mode, but Event output will remain deasserted, see Section 5.2.3 “Event Output Configuration”</p>
bit 0	<p>Event Output Mode (Event Mod.) Bit: 0 = Comparator output (power-up default) 1 = Interrupt output</p> <p>This bit cannot be altered when either of the lock bits is set (bit 6 and bit 7).</p> <p>This bit can be programmed in Shutdown mode, but Event output will remain deasserted.</p>

MCP98244

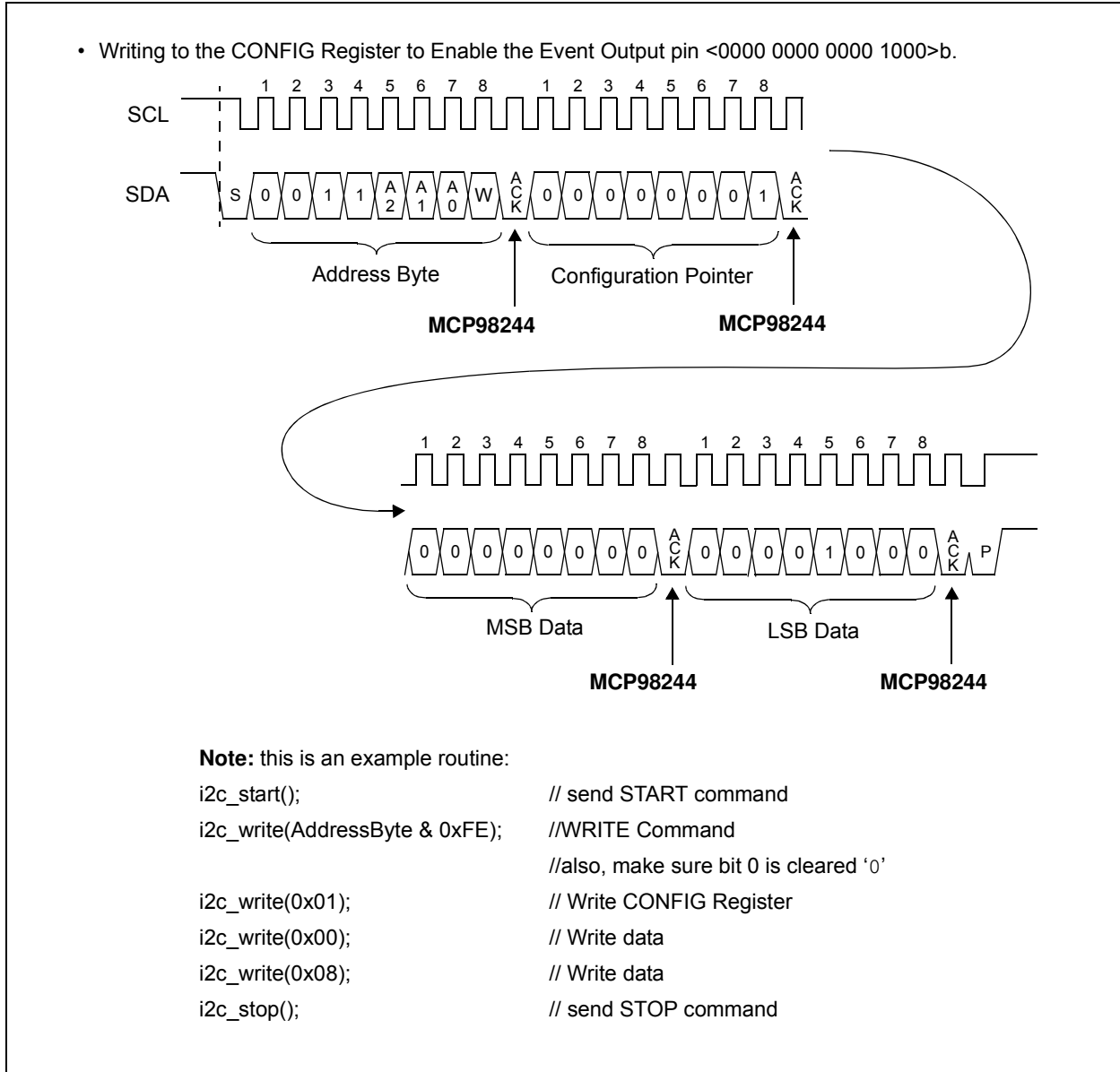
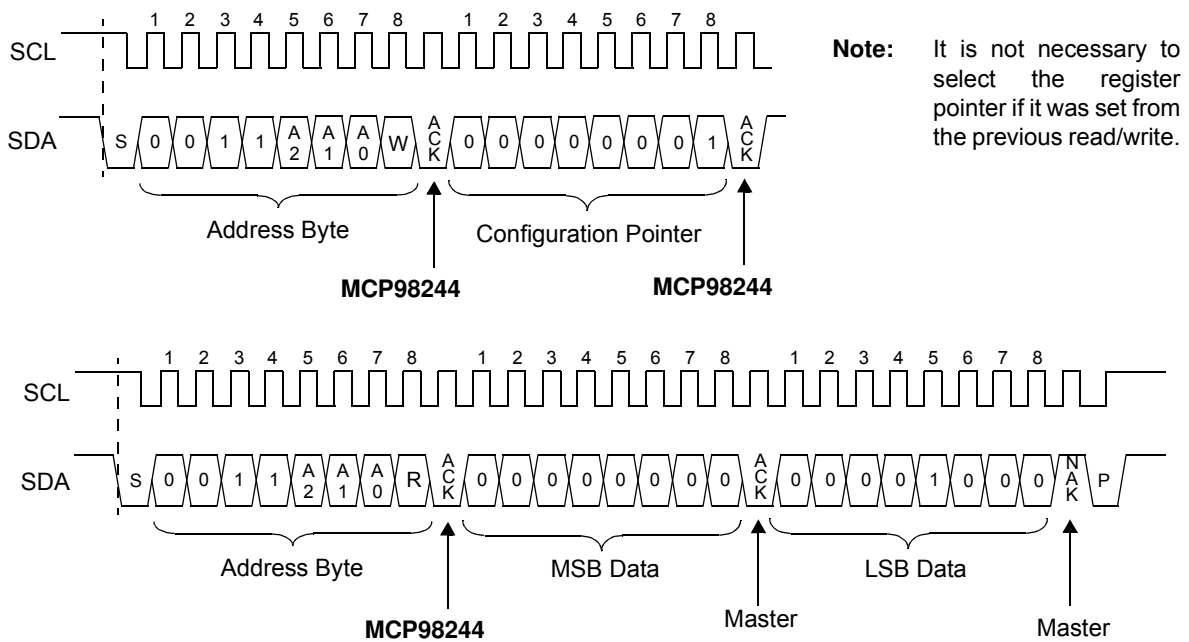

FIGURE 5-3: Timing Diagram for Writing to the Configuration Register (See [Section 4.0 “Serial Communication”](#)).

- Reading the CONFIG Register.



Note: this is an example routine:

```

i2c_start(); // send START command
i2c_write(AddressByte & 0xFE); //WRITE Command
//also, make sure bit 0 is cleared '0'

i2c_write(0x01); // Write CONFIG Register
i2c_start(); // send Repeat START command
i2c_write(AddressByte | 0x01); //READ Command
//also, make sure bit 0 is set '1'

UpperByte = i2c_read(ACK); // READ 8 bits
//and Send ACK bit

LowerByte = i2c_read(NAK); // READ 8 bits
//and Send NAK bit

i2c_stop(); // send STOP command
    
```

FIGURE 5-4: Timing Diagram for Reading from the Configuration Register (See [Section 4.0](#) “Serial Communication”).

MCP98244

5.1.3 UPPER/LOWER/CRITICAL TEMPERATURE LIMIT REGISTERS ($T_{UPPER}/T_{LOWER}/T_{CRIT}$)

The MCP98244 device has a 16-bit read/write Event output Temperature Upper-Boundary Trip register (T_{UPPER}), a 16-bit Lower-Boundary Trip register (T_{LOWER}) and a 16-bit Critical Boundary Trip register (T_{CRIT}) that contains 11-bit data in two's complement format (0.25°C). This data represents the maximum and minimum temperature boundary or temperature window that can be used to monitor ambient temperature. If this feature is enabled ([Section 5.1.2 “Sensor Configuration Register \(CONFIG\)”](#)) and the ambient temperature exceeds the specified boundary or window, the MCP98244 asserts an Event output. (Refer to [Section 5.2.3 “Event Output Configuration”](#)).

REGISTER 5-4: UPPER/LOWER/CRITICAL TEMPERATURE LIMIT REGISTER ($T_{UPPER}/T_{LOWER}/T_{CRIT}$) → ADDRESS '0000 0010'b/'0000 0011'b/'0000 0100'b ([Note 1](#))

U-0	U-0	U-0	R/W-0	R/W-0	R/W-0	R/W-0	R/W-0	
—	—	—	Sign	2^7°C	2^6°C	2^5°C	2^4°C	
bit 15								bit 8

R/W-0	R/W-0	R/W-0	R/W-0	R/W-0	R/W-0	U-0	U-0	
2^3°C	2^2°C	2^1°C	2^0°C	$2^{-1^{\circ}\text{C}}$	$2^{-2^{\circ}\text{C}}$	—	—	
bit 7								bit 0

Legend:

R = Readable bit	W = Writable bit	U = Unimplemented bit, read as '0'
-n = Value at POR	'1' = Bit is set	'0' = Bit is cleared x = Bit is unknown

bit 15-13 **Unimplemented:** Read as '0'

bit 12 **Sign:**
 0 = $T_A \geq 0^{\circ}\text{C}$
 1 = $T_A < 0^{\circ}\text{C}$

bit 11-2 **$T_{UPPER}/T_{LOWER}/T_{CRIT}$:**
 Temperature boundary trip data in two's complement format.

bit 1-0 **Unimplemented:** Read as '0'

Note 1: This table shows two 16-bit registers for T_{UPPER} , T_{LOWER} and T_{CRIT} located at '0000 0010b', '0000 0011b' and '0000 0100b', respectively.

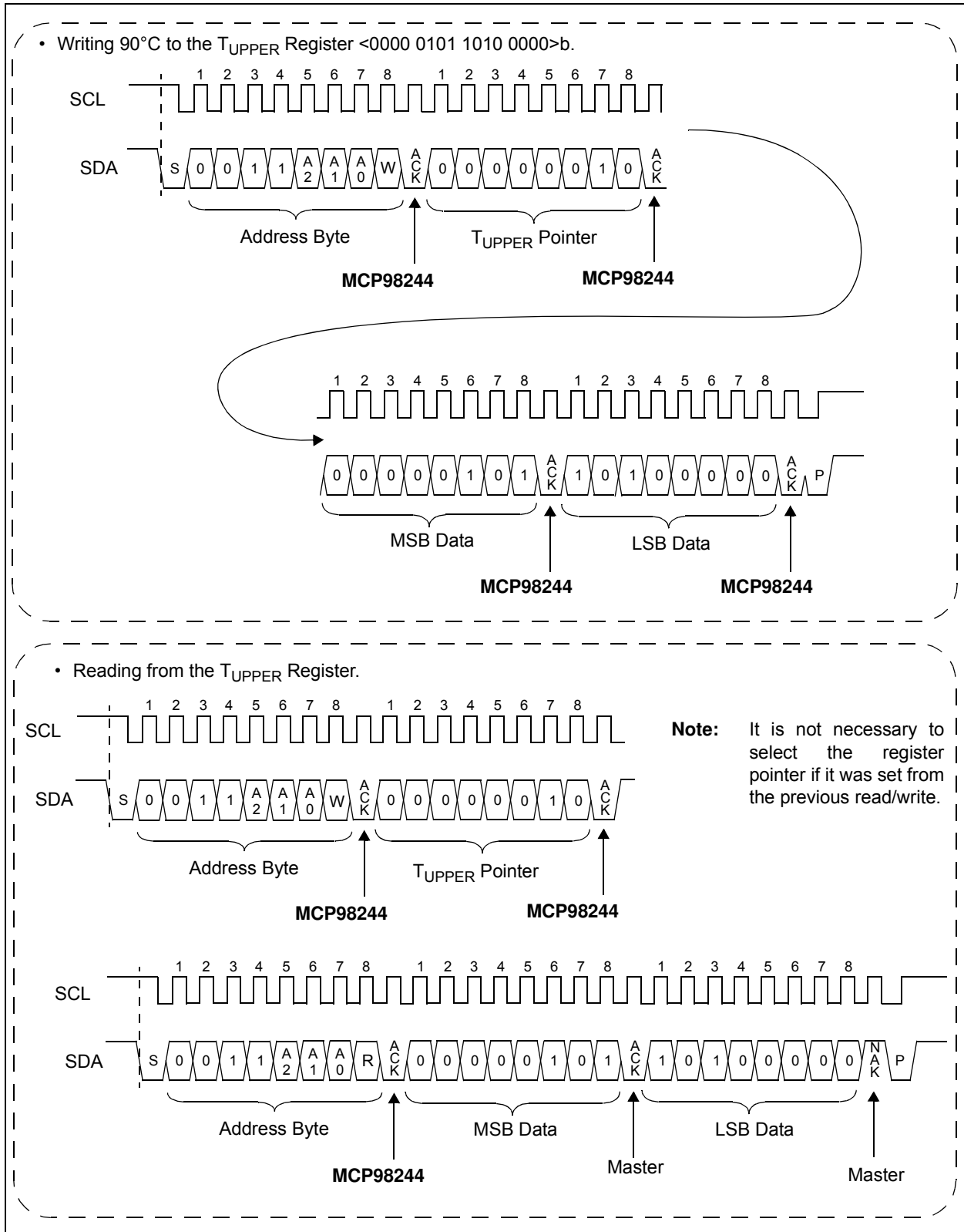

FIGURE 5-5: Timing Diagram for Writing and Reading from the T_{UPPER} Register (See [Section 4.0](#) “Serial Communication”).

MCP98244

5.1.4 AMBIENT TEMPERATURE REGISTER (T_A)

The MCP98244 device uses a band gap temperature sensor circuit to output analog voltage proportional to absolute temperature. An internal $\Delta\Sigma$ ADC is used to convert the analog voltage to a digital word. The converter resolution is set to $0.25^\circ\text{C} + \text{sign}$ (11-bit data). The digital word is loaded to a 16-bit read-only Ambient Temperature register (T_A) that contains 11-bit temperature data in two's complement format.

The T_A register bits (bits 12 through 0) are double-buffered. Therefore, the user can access the register while, in the background, the MCP98244 performs an analog-to-digital conversion. The temperature data from the $\Delta\Sigma$ ADC is loaded in parallel to the T_A register at t_{CONV} refresh rate.

In addition, the T_A register uses three bits (bits 15, 14 and 13) to reflect the Event pin state. This allows the user to identify the cause of the Event output trigger (see [Section 5.2.3 "Event Output Configuration"](#)); bit 15 is set to '1' if T_A is greater than or equal to T_{CRIT} , bit 14 is set to '1' if T_A is greater than T_{UPPER} and bit 13 is set to '1' if T_A is less than T_{LOWER} .

The T_A register bit assignment and boundary conditions are described in [Register 5-5](#).

REGISTER 5-5: AMBIENT TEMPERATURE REGISTER (T_A) → ADDRESS '0000 0101'b (Note 1)

R-0	R-0	R-0	R-0	R-0	R-0	R-0	R-0
T_A vs. T_{CRIT}	T_A vs. T_{UPPER}	T_A vs. T_{LOWER}	SIGN	2^7 °C	2^6 °C	2^5 °C	2^4 °C
bit 15							bit 8

R-0	R-0	R-0	R-0	R-0	R-0	R-0	R-0
2^3 °C	2^2 °C	2^1 °C	2^0 °C	2^{-1} °C	2^{-2} °C	2^{-3} °C	2^{-4} °C
bit 7							bit 0

Legend:			
R = Readable bit	W = Writable bit	U = Unimplemented bit, read as '0'	
-n = Value at POR	'1' = Bit is set	'0' = Bit is cleared	x = Bit is unknown

bit 15 **T_A vs. T_{CRIT} Bit: (Note 1)**

- 0 = $T_A < T_{\text{CRIT}}$
- 1 = $T_A \geq T_{\text{CRIT}}$

bit 14 **T_A vs. T_{UPPER} Bit (Note 1):**

- 0 = $T_A \leq T_{\text{UPPER}}$
- 1 = $T_A > T_{\text{UPPER}}$

bit 13 **T_A vs. T_{LOWER} Bit (Note 1):**

- 0 = $T_A \geq T_{\text{LOWER}}$
- 1 = $T_A < T_{\text{LOWER}}$

bit 12 **SIGN Bit:**

- 0 = $T_A \geq 0^\circ\text{C}$
- 1 = $T_A < 0^\circ\text{C}$

bit 11-0 **Ambient Temperature (T_A) Bits: (Note 2)**

12-bit Ambient Temperature data in two's complement format.

Note 1: Bits 15, 14 and 13 are not affected by the status of the Event output configuration (bits 5 to 0 of CONFIG) ([Register 5-3](#)).

2: Bits 2, 1, and 0 may remain clear '0' depending on the status of the resolution register. The Power-up default is $0.25^\circ\text{C}/\text{bit}$, bits 1 and 0 remain clear '0'.

5.1.4.1 T_A bits to Temperature Conversion

To convert the T_A bits to decimal temperature, the upper three boundary bits (15, 14 and 13) must be masked out. Then determine the sign bit (bit 12) to check positive or negative temperature, shift the bits accordingly and combine the upper and lower bytes of the 16-bit register. The upper byte contains data for temperatures greater than 32°C, while the lower byte contains data for temperature less than 32°C, including fractional data. When combining the upper and lower bytes, the upper byte must be Right-shifted by 4 bits (or multiply by 2^4) and the lower byte must be Left-shifted by 4 bits (or multiply by 2^{-4}). Adding the results of the shifted values provides the temperature data in decimal format; see [Equation 5-1](#).

The temperature bits are in two's complement format, therefore, positive temperature data and negative temperature data are computed differently. [Equation 5-1](#) shows the temperature computation. The example instruction code outlined in [Figure 5-6](#) shows the communication flow, also see [Figure 5-7](#) for timing diagram.

EQUATION 5-1: BYTES TO TEMPERATURE CONVERSION

Temperature $\geq 0^\circ\text{C}$ (bit 12 or Sign bit = 0)

$$T_A = (\text{UpperByte} \times 2^4 + \text{LowerByte} \times 2^{-4})$$

Temperature $< 0^\circ\text{C}$ (bit 12 or Sign bit = 1)

$$T_A = (\text{UpperByte} \times 2^4 + \text{LowerByte} \times 2^{-4}) - 256$$

Where:

T_A = Ambient Temperature ($^\circ\text{C}$)

UpperByte = T_A bit 11 to bit 8

LowerByte = T_A bit 7 to bit 0

This example routine assumes the variables and I²C communication subroutines are predefined:

```

i2c_start(); // send START command
i2c_write(AddressByte & 0xFE); //WRITE Command
//also, make sure bit 0 is cleared '0'

i2c_write(0x05); // Write TA Register Address
i2c_start(); //Repeat START
i2c_write(AddressByte | 0x01); // READ Command
//also, make sure bit 0 is Set '1'

UpperByte = i2c_read(ACK); // READ 8 bits
//and Send ACK bit

LowerByte = i2c_read(NAK); // READ 8 bits
//and Send NAK bit

i2c_stop(); // send STOP command
//Convert the temperature data
//First Check flag bits
if ((UpperByte & 0x80) == 0x80){ //TA ≥ TCRIT
}
if ((UpperByte & 0x40) == 0x40){ //TA > TUPPER
}
if ((UpperByte & 0x20) == 0x20){ //TA < TLOWER
}
UpperByte = UpperByte & 0x1F; //Clear flag bits
if ((UpperByte & 0x10) == 0x10){ //TA < 0°C
    UpperByte = UpperByte & 0x0F; //Clear SIGN
    Temperature = 256 - (UpperByte x 16 + LowerByte / 16);
}else //TA ≥ 0°C
    Temperature = (UpperByte x 16 + LowerByte / 16);
//Temperature = Ambient Temperature (°C)
    
```

FIGURE 5-6: Example Instruction Code.

MCP98244

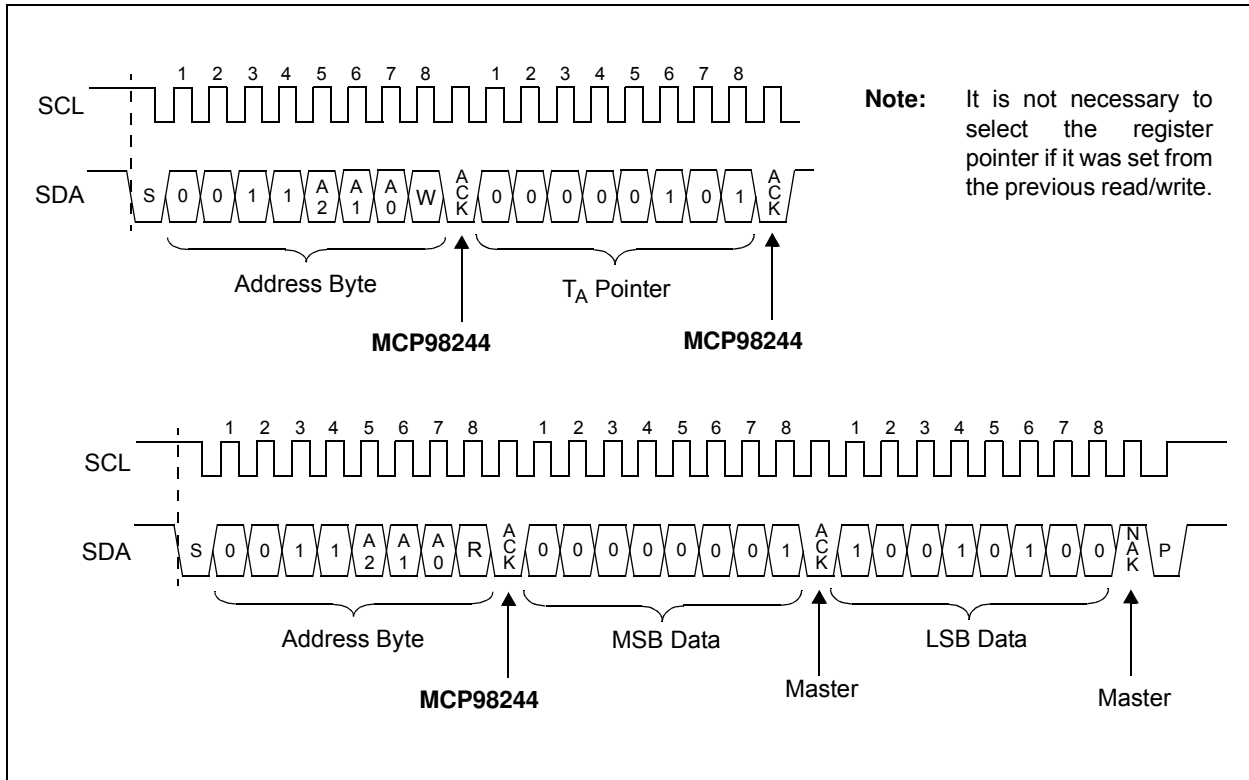

FIGURE 5-7: Timing Diagram for Reading +25.25°C Temperature from the T_A Register (See Section 4.0 “Serial Communication”).

5.1.5 MANUFACTURER ID REGISTER

This register is used to identify the manufacturer of the device in order to perform manufacturer specific operation. The Manufacturer ID for the MCP98244 is 0x0054 (hexadecimal).

REGISTER 5-6: MANUFACTURER ID REGISTER (READ-ONLY) → ADDRESS '0000 0110'₂

R-0	R-0	R-0	R-0	R-0	R-0	R-0	R-0
Manufacturer ID							
bit 15				bit 8			

R-0	R-1	R-0	R-1	R-0	R-1	R-0	R-0
Manufacturer ID							
bit 7				bit 0			

Legend:

R = Readable bit W = Writable bit U = Unimplemented bit, read as '0'
 -n = Value at POR '1' = Bit is set '0' = Bit is cleared x = Bit is unknown

bit 15-0 **Device Manufacturer Identification Number**

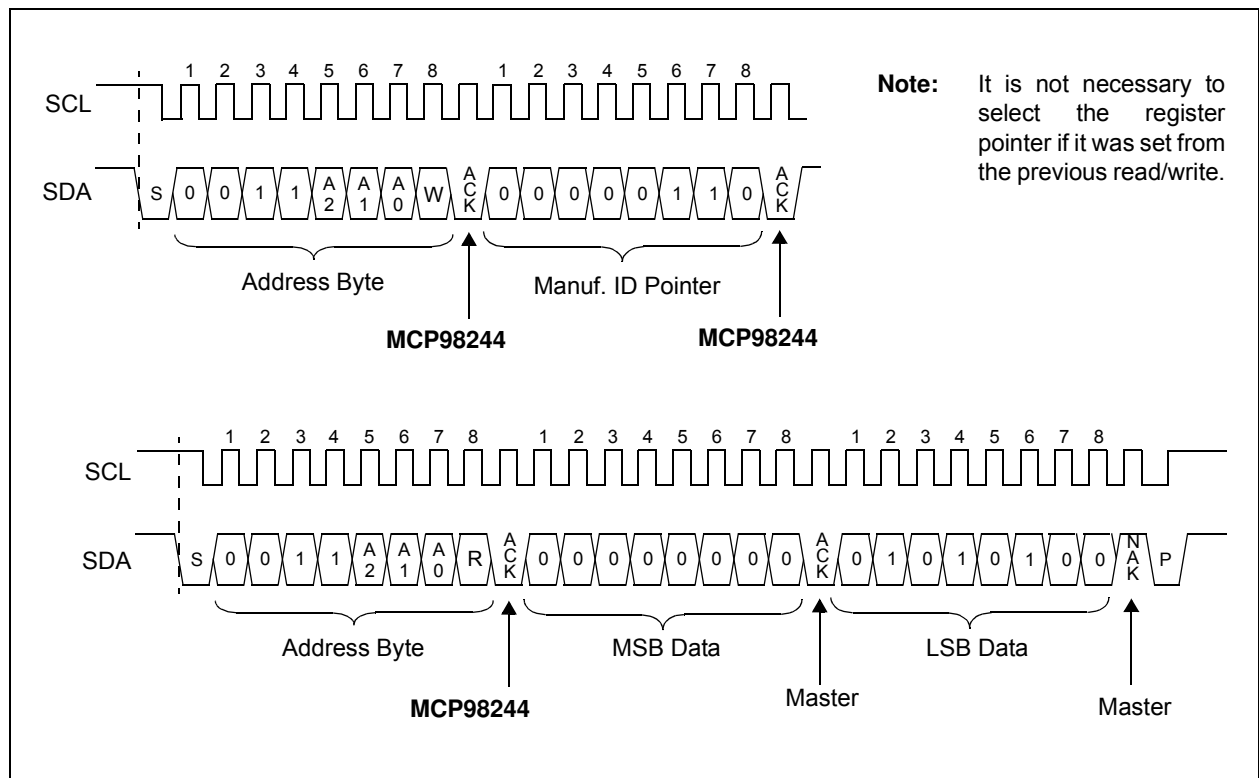

FIGURE 5-8: Timing Diagram for Reading the Manufacturer ID Register (See [Section 4.0 “Serial Communication”](#)).