



Chipsmall Limited consists of a professional team with an average of over 10 year of expertise in the distribution of electronic components. Based in Hongkong, we have already established firm and mutual-benefit business relationships with customers from,Europe,America and south Asia,supplying obsolete and hard-to-find components to meet their specific needs.

With the principle of “Quality Parts,Customers Priority,Honest Operation,and Considerate Service”,our business mainly focus on the distribution of electronic components. Line cards we deal with include Microchip,ALPS,ROHM,Xilinx,Pulse,ON,Everlight and Freescale. Main products comprise IC,Modules,Potentiometer,IC Socket,Relay,Connector.Our parts cover such applications as commercial,industrial, and automotives areas.

We are looking forward to setting up business relationship with you and hope to provide you with the best service and solution. Let us make a better world for our industry!



Contact us

Tel: +86-755-8981 8866 Fax: +86-755-8427 6832

Email & Skype: info@chipsmall.com Web: www.chipsmall.com

Address: A1208, Overseas Decoration Building, #122 Zhenhua RD., Futian, Shenzhen, China



MCS3142 Dual KEELOQ[®] Technology Encoder Data Sheet

Features Overview:

SECURITY

- Ultimate KEELOQ[®] Technology:
 - Programmable 32-bit serial number
 - AES-128 block cipher
 - Programmable 128-bit crypt key
 - Timekeeping based on external 32.768 kHz crystal
 - 192-bit transmission code length:
 - 32-bit unencrypted portion
 - 128-bit encrypted, hopping code portion
 - 32-bit authorization check
- Classic KEELOQ Technology:
 - Programmable 28-bit serial number
 - Data based on Classic KEELOQ Technology:
 - KEELOQ technology 32-bit block cipher
 - Programmable 64-bit crypt key
 - KEELOQ technology secure learn
 - Programmable 60-bit seed value
 - 66-bit transmission code length:
 - 34-bit unencrypted portion
 - 32-bit encrypted, hopping code portion
- Operating Features:
 - 1.8 to 3.6V operation
 - Four switch inputs
 - 15 functions available
 - Configurable button modes
 - One active-low LED drive
 - Configurable minimum code word completion
- RF:
 - Configurable bit rate
 - Configurable modulation, supporting FSK and OOK
 - Configurable data modulation, supporting PWM and Manchester
- Other:
 - Button inputs have internal pull-up resistors
 - LED output

Typical Applications:

MCS3142 is ideal for Remote Keyless Entry (RKE) applications. These applications include:

- Automotive RKE Systems
- Automotive Alarm Systems
- Gate and Garage Door Openers
- Home Security Systems
- Security and Safety Sensors
- Remote Control
- Remote Keypad
- Wireless Sensors

Package Type:

- 20-pin TSSOP

FIGURE 1: 20-PIN TSSOP

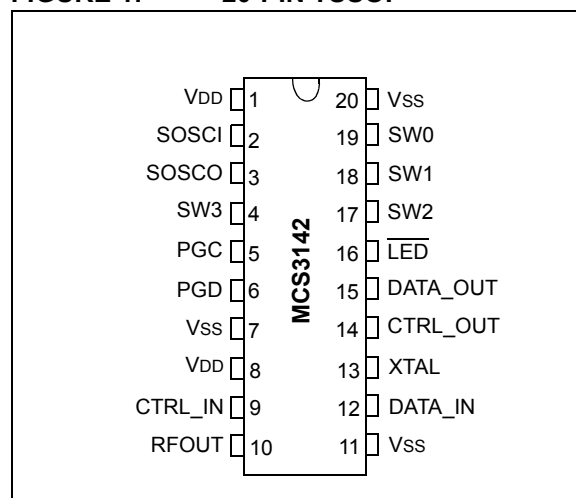

MCS3142

TABLE 1: PIN DESCRIPTION

Name	20-Pin TSSOP	Input Type	Output Type	Description
VDD	1	Power	—	Power
SOSCI	2	Analog	—	Secondary Oscillator
SOSCO	3	Analog	—	Secondary Oscillator
SW3	4	TTL	—	Switch 3 Input
PGC	5	TTL	—	Programming Clock
PGD	6	TTL	TTL	Programming Data
—	7	—	—	No Connection; Tie to Vss
VDD	8	Power	—	Power
CTRL_IN	9	TTL	—	Transmitter Clock
RFOUT	10	—	RF	Transmitter Output
Vss	11	Power	—	Power
DATA_IN	12	TTL	—	Transmitter Data
XTAL	13	Analog	—	Transmitter Reference Oscillator
CTRL_OUT	14	—	TTL	Transmitter Clock
DATA_OUT	15	—	TTL	Transmitter Data
LED	16	—	TTL	LED Output (active-low)
SW2	17	TTL	—	Switch 2 Input
SW1	18	TTL	—	Switch 1 Input
SW0	19	TTL	—	Switch 0 Input
Vss	20	Power	—	Power

Table of Contents

1.0	General Description	4
2.0	Device Description	6
3.0	Memory Organization	7
4.0	Classic KEELoQ® Operation	16
5.0	Ultimate KEELoQ Operation	18
6.0	Transmitter Operation	21
7.0	Device Operation	25
8.0	Integrating MCS3142 into a System	27
9.0	Electrical Specifications	29
10.0	Packaging Information	30
	The Microchip Web Site	34
	Customer Change Notification Service	34
	Customer Support	34
	Product Identification System	35

TO OUR VALUED CUSTOMERS

It is our intention to provide our valued customers with the best documentation possible to ensure successful use of your Microchip products. To this end, we will continue to improve our publications to better suit your needs. Our publications will be refined and enhanced as new volumes and updates are introduced.

If you have any questions or comments regarding this publication, please contact the Marketing Communications Department via E-mail at docerrors@microchip.com. We welcome your feedback.

Most Current Data Sheet

To obtain the most up-to-date version of this data sheet, please register at our Worldwide Web site at:

<http://www.microchip.com>

You can determine the version of a data sheet by examining its literature number found on the bottom outside corner of any page. The last character of the literature number is the version number, (e.g., DS30000000A is version A of document DS30000000).

Errata

An errata sheet, describing minor operational differences from the data sheet and recommended workarounds, may exist for current devices. As device/documentation issues become known to us, we will publish an errata sheet. The errata will specify the revision of silicon and revision of document to which it applies.

To determine if an errata sheet exists for a particular device, please check with one of the following:

- Microchip's Worldwide Web site; <http://www.microchip.com>
- Your local Microchip sales office (see last page)

When contacting a sales office, please specify which device, revision of silicon and data sheet (include literature number) you are using.

Customer Notification System

Register on our web site at www.microchip.com to receive the most current information on all of our products.

MCS3142

1.0 GENERAL DESCRIPTION

MCS3142 is a dual encoder, designed for secure Remote Keyless Entry (RKE) and secure remote control systems. MCS3142 utilizes both the Classic KEELOQ code hopping technology and the new Ultimate KEELOQ technology time-stamping solution. Both of these encoders incorporate high security, a small package outline and low cost to make this device a perfect solution for unidirectional authentication systems and access control systems.

Classic KEELOQ technology combines a hopping code generated by a nonlinear encryption algorithm, a serial number and Status bits to create a secure transmission code. The length of the transmission eliminates the threat of code scanning and code grabbing access techniques.

Ultimate KEELOQ technology is generated using the industry standard AES-128 encryption algorithm, a serial number and a timer-driven message counter which continuously increments, independent of events, to provide a better, more secure solution. The timekeeping functionality protects against jam-and-replay attack techniques.

The crypt key, serial number and configuration data are stored in an EEPROM array which is not accessible via any external connection. The EEPROM data is programmable but read-protected. The data can be verified only after an automatic erase and programming operation. This protects against attempts to gain access to keys or manipulate synchronization values. In addition, MCS3142 provides an easy to use serial interface for programming the necessary keys, system parameters and configuration data.

1.1 Key Terms

The following is a list of key terms used throughout this data sheet. For additional information on KEELOQ technology and code hopping, refer to “*An Introduction to KEELOQ® Code Hopping*” Technical Brief (DS91002).

- **RKE:** Remote Keyless Entry
- **Function Code:** It indicates what button input(s) activated the transmission. It encompasses the function code bits.
- **Code Hopping:** A method by which a code, viewed externally to the system, appears to change unpredictably each time it is transmitted
- **Code Word:** A block of data that is repeatedly transmitted upon button activation
- **Transmission:** A data stream consisting of repeating code words

- **Crypt Key:** A unique and secret number (64-bit for Classic KEELOQ technology, 128-bit for Ultimate KEELOQ technology) used to encrypt and decrypt data. In a symmetrical block cipher such as those used on MCS3142, the encryption and decryption keys are equal and, therefore, will generally be referred to as the crypt key.
- **Encoder:** A device that generates and encodes data
- **Encryption Algorithm:** A method whereby data is scrambled using a crypt key. The data can only be interpreted by the respective decryption algorithm using the same crypt key.
- **Decoder:** A device that decodes data received from an encoder
- **Decryption Algorithm:** A recipe whereby data, scrambled by an encryption algorithm, can be unscrambled using the same crypt key
- **Time-Stamp:** The time-derived value recorded with a message
- **Learn:** Learning involves the receiver calculating the transmitter’s appropriate crypt key, decrypting the received hopping code and storing the serial number, synchronization counter or timer value, and crypt key in EEPROM. The KEELOQ technology product family facilitates several learning strategies to be implemented on the decoder. The following are examples of what can be done:
 - **Simple Learning:** The receiver uses a fixed crypt key. The crypt key is common to every component used by the same manufacturer.
 - **Normal Learning:** The receiver derives a crypt key from the encoder serial number. Every transmitter has a unique crypt key.
 - **Secure Learning:** The receiver derives a crypt key from the encoder seed value. Every encoder has a unique seed value that is only transmitted by a special button combination.
- **Manufacturer’s Code:** A unique and secret number (64-bit for Classic KEELOQ technology, 128-bit for Ultimate KEELOQ technology) used to derive crypt keys. Each encoder is programmed with a crypt key that is a function of the manufacturer’s code. Each decoder is programmed with the manufacturer’s code itself.

The MCS3142 code hopping encoder is designed specifically for keyless entry systems. Typical applications include vehicles and home garage door openers. The encoder portion of a keyless entry system is integrated into a transmitter carried by the user. The transmitter is operated to gain access to a vehicle or a restricted area. MCS3142 is meant to be a cost-effective, yet secure solution to such systems, requiring very few external components (see [Figure 2-1](#)).

Most low-end keyless entry transmitters are given a fixed identification code that is transmitted every time a button is pushed. The number of unique identification codes in a low-end system is usually a relatively small number. These shortcomings provide an opportunity for a sophisticated thief to create a device that 'grabs' a transmission and retransmits it later, or a device that quickly 'scans' all possible identification codes until the correct one is found.

MCS3142, on the other hand, employs both the Classic and Ultimate KEELOQ code hopping technology. The high-security level of MCS3142 is based on the patented KEELOQ technology.

For Classic KEELOQ technology, a block cipher based on a block length of 32 bits and a key length of 64 bits is used. The algorithm obscures the information in such a way that if a single hopping code data bit changes (before encryption), statistically more than 50% of the encrypted data bits will change.

Ultimate KEELOQ technology uses the industry standard AES-128 encryption algorithm to obscure data using 128 bits for both its block and key length. In addition to the security of Classic KEELOQ technology, Ultimate KEELOQ technology sends a time-stamp as part of the transmission. This can prevent other more sophisticated attacks such as the 'jam-and-relay' attack.

MCS3142

2.0 DEVICE DESCRIPTION

As shown in the typical application circuit (Figure 2-1), MCS3142 is a simple device to use. It requires only the addition of buttons, an external 32.768 kHz watch crystal, a transmitter reference oscillator, and RF circuitry for use as the transmitter in your security application. See Table 1 for a description of each pin.

FIGURE 2-1: TYPICAL CIRCUIT

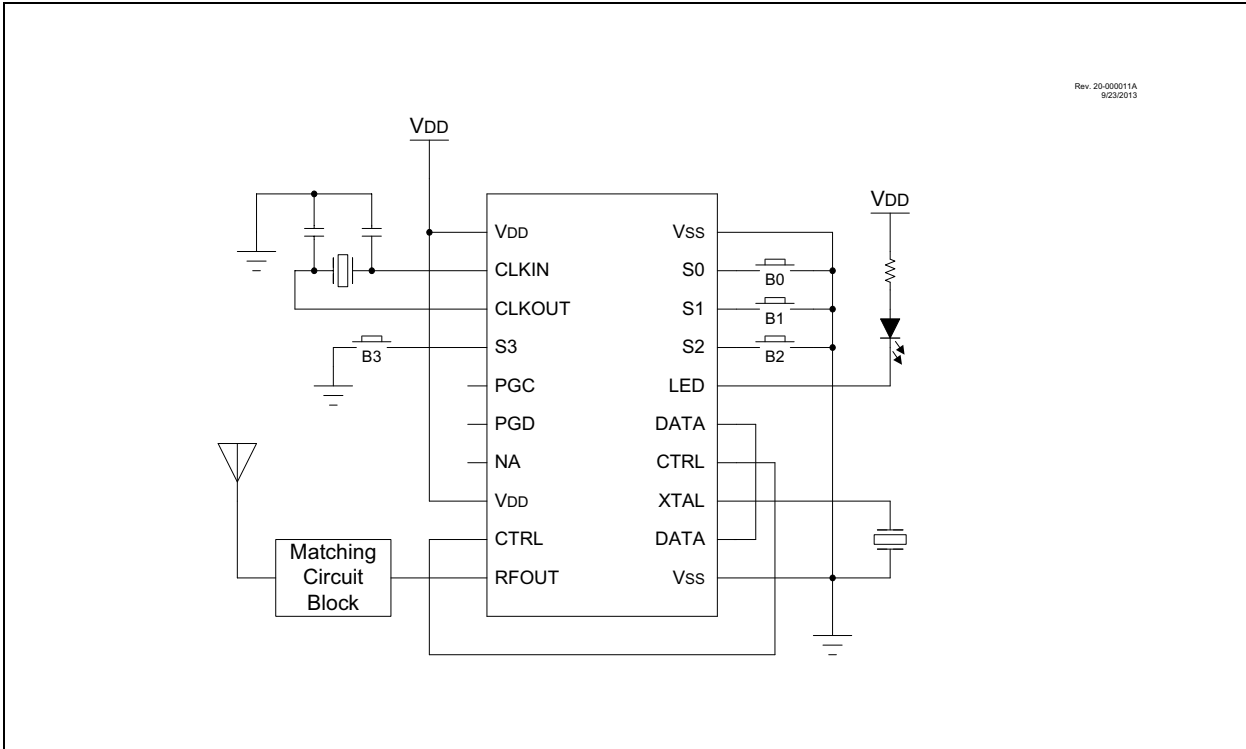

3.0 MEMORY ORGANIZATION

MCS3142 has 128 bytes of configuration data. In general, the Configuration bytes can be divided into three categories: those options related to the Classic KEELOQ technology encoder, those options related to the Ultimate KEELOQ technology encoder, and those options related to the transmitter and device operation shared by the two encoders.

TABLE 3-1: CONFIGURATION REGISTERS

Address	Size (Bytes)	Description
0x00-0x07	8	Classic KEELOQ [®] Technology Crypt Key
0x08-0x0F	8	Classic KEELOQ Technology Seed Value
0x10-0x13	4	Classic KEELOQ Technology Serial Number
0x14-0x15	2	Classic KEELOQ Technology DISC Value
0x16-0x17	2	Classic KEELOQ Technology Encoder Configuration
0x18-0x19	2	Classic KEELOQ Technology Transmitter Configuration
0x1A	1	Classic KEELOQ Technology Minimum Packet
0x1B-0x1C	2	Classic KEELOQ Technology Maximum Packet
0x1D	1	Classic KEELOQ Technology Time Element PR2 Value
0x1E-0x2D	16	Ultimate KEELOQ Technology Crypt Key
0x2E-0x3D	16	Ultimate KEELOQ Technology Seed Value
0x3E-0x41	4	Ultimate KEELOQ Technology Serial Number
0x42-0x43	2	Reserved
0x44-0x53	16	Ultimate KEELOQ Technology Authorization Code
0x54-0x55	2	Ultimate KEELOQ Technology Encoder Configuration
0x56-0x57	2	Ultimate KEELOQ Technology Transmitter Configuration
0x58	1	Ultimate KEELOQ Technology Minimum Packet
0x59-0x5A	2	Ultimate KEELOQ Technology Maximum Packet
0x5B	1	Ultimate KEELOQ Technology Time Element PR2 Value
0x5C-0x5E	3	Encoder Frequency Setting
0x5F-0x60	2	Encoder Button Configuration
0x61-0x62	2	Seed Packet Button Configuration
0x63-0x65	3	Ultimate KEELOQ Technology Synchronization Counter, Copy 1
0x66	1	Ultimate KEELOQ Technology Synchronization Counter CRC, Copy 1
0x67-0x68	2	Classic KEELOQ Technology Synchronization Counter, Copy 1
0x69	1	Classic KEELOQ Technology Synchronization Counter CRC, Copy 1
0x6A-0x6B	2	Ultimate KEELOQ Technology Reset Counter, Copy 1
0x6C	1	Ultimate KEELOQ Technology Reset Counter CRC, Copy 1
0x6D-0x70	4	Ultimate KEELOQ Technology Low-Speed Timer, Copy 1
0x71	1	Ultimate KEELOQ Technology Low-Speed Timer CRC, Copy 1
0x72-0x74	3	Ultimate KEELOQ Technology Synchronization Counter, Copy 2
0x75	1	Reserved
0x76-0x77	2	Classic KEELOQ Technology Synchronization Counter, Copy 2
0x78	1	Reserved
0x79-0x7A	2	Ultimate KEELOQ Technology Reset Counter, Copy 2
0x7B	1	Reserved
0x7C-0x7F	4	Ultimate KEELOQ Technology Timer, Copy 2

3.1 Counter and Timer Protection

Because they are written during normal operation of the device, the two synchronization counters, Reset counter and time value receive special protection to guard against data loss from unexpected power loss. An 8-bit CRC is calculated and stored alongside each variable. Further, each variable is duplicated in a different portion of memory. Whenever a value is read, the CRC is calculated and verified against the stored value. If there is a mismatch, the second copy of the data is read instead. The CRC calculation uses a polynomial represented by $x^8 + x^4 + x^3 + x^2 + 1$. [Example 3-1](#) describes a sample C function to compute this value.

EXAMPLE 3-1: CRC CALCULATION

```
static uint8_t crc(const uint8_t* buffer, size_t len){
    uint8_t bitcount;
    uint8_t c = 0xFF;

    while(len--){
        c ^= *buffer++;

        for(bitcount = 0; bitcount < 8; bitcount++){
            if((c & 0x80) != 0){
                c <<= 1;
                c ^= 0x1D;
            }else{
                c <<= 1;
            }
        }
    }

    return ~c;
}
```

3.2 Configuration Byte Details

The following tables describe Configuration bytes in detail.

TABLE 3-2: CLASSIC KEELoQ® TECHNOLOGY CRYPT KEY CONFIGURATION REGISTERS

Byte Address	Bit	Description	Values
0x00	7:0	Crypt Key	Least Significant eight bits of the crypt key
0x01	7:0		Byte 1 of the crypt key
0x02	7:0		Byte 2 of the crypt key
0x03	7:0		Byte 3 of the crypt key
0x04	7:0		Byte 4 of the crypt key
0x05	7:0		Byte 5 of the crypt key
0x06	7:0		Byte 6 of the crypt key
0x07	7:0		Most Significant eight bits of the crypt key

TABLE 3-3: CLASSIC KEELoQ® TECHNOLOGY SEED CONFIGURATION REGISTERS

Byte Address	Bit	Description	Values
0x08	7:0	Seed	Least Significant eight bits of the seed
0x09	7:0		Byte 1 of the seed
0x0A	7:0		Byte 2 of the seed
0x0B	7:0		Byte 3 of the seed
0x0C	7:0		Byte 4 of the seed
0x0D	7:0		Byte 5 of the seed
0x0E	7:0		Byte 6 of the seed
0x0F	7:0		Most Significant eight bits of the seed

TABLE 3-4: CLASSIC KEELoQ® TECHNOLOGY SERIAL NUMBER CONFIGURATION REGISTERS

Byte Address	Bit	Description	Values
0x10	7:0	Serial Number	Least Significant eight bits of the serial number
0x11	7:0		Byte 1 of the serial number
0x12	7:0		Byte 2 of the serial number
0x13	3:0		Most Significant four bits of the serial number
	7:4	Reserved	Maintain as '0000'

TABLE 3-5: CLASSIC KEELoQ® TECHNOLOGY DISC CONFIGURATION REGISTERS

Byte Address	Bit	Description	Values
0x14	7:0	DISC Value	Least Significant eight bits of DISC value
0x15	1:0		Most Significant two bits of DISC value
	7:2	Reserved	Maintain as '000000'

MCS3142

TABLE 3-6: CLASSIC KEELoQ® TECHNOLOGY ENCODER CONFIGURATION REGISTERS

Byte Address	Bit	Description	Values
0x16	7:6	Seed Option	00 = No seed
			01 = Limited and immediate
			10 = Permanent and delayed
			11 = Permanent and immediate
	5:2	Reserved	Leave '0000'
1:0	Time Element Clock Prescaler	00 = 1:1	
		01 = 1:4	
		10 = 1:16	
		11 = 1:64	
0x17	7	Reserved	Leave '0'
	6:5	Blank Alternate Code Word Configuration	00 = All words transmitted
			01 = One in two words transmitted
			10 = One in four words transmitted
			11 = Reserved; illegal value
4:1	Reserved	—	
0	Line Encoding	0 = PWM	
		1 = Manchester	

TABLE 3-7: CLASSIC KEELoQ® TECHNOLOGY TRANSMITTER CONFIGURATION REGISTERS

Byte Address	Bit	Description	Values
0x18	7:5	Frequency Deviation	Low three bits of frequency deviation calculation (see Section 6.4 “Center Frequency and Frequency Deviation”)
	4	Output Power	0 = 0 dBm 1 = +10 dBm
	3:0	Reserved	Reserved, maintain as '1100'
0x19	7	Reserved	Reserved, maintain as '0'
	6	Data Encoding	0 = FSK
			1 = OOK
	5	Band	0 = 310-450 MHz
1 = 868-870, 902-928 MHz			
4:0	Frequency Deviation	High five bits of frequency deviation calculation	

TABLE 3-8: CLASSIC KEELoQ® TECHNOLOGY MINIMUM AND MAXIMUM CODE WORDS COUNT CONFIGURATION REGISTERS

Byte Address	Bit	Description	Values
0x1A	7:0	Minimum Code Word Count	Integer value of the minimum number of code words sent
0x1B	7:0	Maximum Code Word Count	Least Significant eight bits of value of the maximum number of code words sent
0x1C	7:0		Most Significant eight bits of value of the maximum number of code words sent

TABLE 3-9: CLASSIC KEELOQ® TECHNOLOGY TIME ELEMENT VALUE CONFIGURATION REGISTER

Byte Address	Bit	Description	Values
0x1D	7:0	Time Element Timer Value	See Section 6.2 “Baud Rate”

TABLE 3-10: ULTIMATE KEELOQ® TECHNOLOGY CRYPT KEY CONFIGURATION REGISTERS

Byte Address	Bit	Description	Values
0x1E	7:0	Crypt Key	Least Significant eight bits of the crypt key
0x1F	7:0		Byte 1 of the crypt key
0x20	7:0		Byte 2 of the crypt key
0x21	7:0		Byte 3 of the crypt key
0x22	7:0		Byte 4 of the crypt key
0x23	7:0		Byte 5 of the crypt key
0x24	7:0		Byte 6 of the crypt key
0x25	7:0		Byte 7 of the crypt key
0x26	7:0		Byte 8 of the crypt key
0x27	7:0		Byte 9 of the crypt key
0x28	7:0		Byte 10 of the crypt key
0x29	7:0		Byte 11 of the crypt key
0x2A	7:0		Byte 12 of the crypt key
0x2B	7:0		Byte 13 of the crypt key
0x2C	7:0		Byte 14 of the crypt key
0x2D	7:0	Most Significant eight bits of the crypt key	

TABLE 3-11: ULTIMATE KEELOQ® TECHNOLOGY SEED CONFIGURATION REGISTERS

Byte Address	Bit	Description	Values
0x2E	7:0	Seed	Least Significant eight bits of the seed
0x2F	7:0		Byte 1 of the seed
0x30	7:0		Byte 2 of the seed
0x31	7:0		Byte 3 of the seed
0x32	7:0		Byte 4 of the seed
0x33	7:0		Byte 5 of the seed
0x34	7:0		Byte 6 of the seed
0x35	7:0		Byte 7 of the seed
0x36	7:0		Byte 8 of the seed
0x37	7:0		Byte 9 of the seed
0x38	7:0		Byte 10 of the seed
0x39	7:0		Byte 11 of the seed
0x3A	7:0		Byte 12 of the seed
0x3B	7:0		Byte 13 of the seed
0x3C	7:0		Byte 14 of the seed
0x3D	7:0	Most Significant eight bits of the seed	

MCS3142

TABLE 3-12: ULTIMATE KEELoQ® TECHNOLOGY SERIAL NUMBER CONFIGURATION REGISTERS

Byte Address	Bit	Description	Values
0x3E	7:0	Serial Number	Least Significant eight bits of the serial number
0x3F	7:0		Byte 1 of the serial number
0x40	7:0		Byte 2 of the serial number
0x41	7:0		Most Significant eight bits of the serial number

TABLE 3-13: ULTIMATE KEELoQ® TECHNOLOGY AUTHORIZATION KEY CONFIGURATION REGISTERS

Byte Address	Bit	Description	Values
0x44	7:0	Authorization Key	Least Significant eight bits of the authorization key
0x45	7:0		Byte 1 of the authorization key
0x46	7:0		Byte 2 of the authorization key
0x47	7:0		Byte 3 of the authorization key
0x48	7:0		Byte 4 of the authorization key
0x49	7:0		Byte 5 of the authorization key
0x4A	7:0		Byte 6 of the authorization key
0x4B	7:0		Byte 7 of the authorization key
0x4C	7:0		Byte 8 of the authorization key
0x4D	7:0		Byte 9 of the authorization key
0x4E	7:0		Byte 10 of the authorization key
0x4F	7:0		Byte 11 of the authorization key
0x50	7:0		Byte 12 of the authorization key
0x51	7:0		Byte 13 of the authorization key
0x52	7:0		Byte 14 of the authorization key
0x53	7:0		Most Significant eight bits of the authorization key

TABLE 3-14: ULTIMATE KEELoQ® TECHNOLOGY ENCODER CONFIGURATION REGISTERS

Byte Address	Bit	Description	Values
0x54	7:6	Seed Option	00 = No seed
			01 = Limited and immediate
			10 = Permanent and delayed
			11 = Permanent and immediate
	5:2	Reserved	Leave '0000'
	1:0	Time Element Clock Prescaler	00 = 1:1
			01 = 1:4
			10 = 1:16
11 = 1:64			

TABLE 3-14: ULTIMATE KEELOQ® TECHNOLOGY ENCODER CONFIGURATION REGISTERS

0x55	7	Reserved	Leave '0'
	6:5	Blank Alternate Code Word Configuration	00 = All words transmitted
			01 = One in two words transmitted
			10 = One in four words transmitted
			11 = Reserved; illegal value
4:1	Reserved		
0	Line Encoding	0 = PWM	
		1 = Manchester	

TABLE 3-15: ULTIMATE KEELOQ® TECHNOLOGY TRANSMITTER CONFIGURATION REGISTERS

Byte Address	Bit	Description	Values
0x56	7:5	Frequency Deviation	Low three bits of frequency deviation calculation (see Section 6.4 “Center Frequency and Frequency Deviation”)
	4	Output Power	0 = 0 dBm 1 = +10 dBm
	3:0	Reserved	Reserved, maintain as '1100'
0x57	7	Reserved	Reserved, maintain as '0'
	6	Data Encoding	0 = FSK
			1 = OOK
	5	Band	0 = 310-450 MHz
1 = 868-870, 902-928 MHz			
4:0	Frequency Deviation	High five bits of frequency deviation calculation (see Section 6.4 “Center Frequency and Frequency Deviation”)	

TABLE 3-16: ULTIMATE KEELOQ® TECHNOLOGY MINIMUM AND MAXIMUM CODE WORDS COUNT CONFIGURATION REGISTERS

Byte Address	Bit	Description	Values
0x58	7:0	Minimum Code Word Count	Integer value of the minimum number of code words sent
0x59	7:0	Maximum Code Word Count	Least Significant eight bits of value of the maximum number of code words sent
0x5A	7:0		Most Significant eight bits of value of the maximum number of code words sent

TABLE 3-17: ULTIMATE KEELOQ® TECHNOLOGY TIME ELEMENT VALUE CONFIGURATION REGISTER

Byte Address	Bit	Description	Values
0x5B	7:0	Time Element Timer Value	See Section 5.2 “Encoder Time-Stamp”

TABLE 3-18: ENCODER FREQUENCY CONFIGURATION REGISTERS

Byte Address	Bit	Description	Values
0x5C	7:0	RF Frequency	Least Significant Byte of encoder frequency
0x5D	7:0		Middle byte of encoder frequency
0x5E	7:0		Most Significant Byte of encoder frequency

TABLE 3-19: ENCODER BUTTON ASSIGNMENT CONFIGURATION REGISTERS

Byte Address	Bit	Description	Values
0x5F	7	Encoder Assignment when S0, S1, S2 active; S3 inactive	0 = Classic KEELOQ® 1 = Ultimate KEELOQ®
	6	Encoder Assignment when S1, S2 active; S0, S3 inactive	
	5	Encoder Assignment when S0, S2 active; S1, S3 inactive	
	4	Encoder Assignment when S2 active; S0, S1, S3 inactive	
	3	Encoder Assignment when S0, S1 active; S2, S3 inactive	
	2	Encoder Assignment when S1 active; S0, S2, S3 inactive	
	1	Encoder Assignment when S0 active; S1, S2, S3 inactive	
	0	Reserved	
0x60	7	Encoder Assignment when S0, S1, S2, S3 active	
	6	Encoder Assignment when S1, S2, S3 active; S0 inactive	
	5	Encoder Assignment when S0, S2, S3 active; S1 inactive	
	4	Encoder Assignment when S2, S3 active; S0, S1 inactive	
	3	Encoder Assignment when S0, S1, S3 active; S2 inactive	
	2	Encoder Assignment when S1, S3 active; S0, S2 inactive	
	1	Encoder Assignment when S0, S3 active; S1, S2 inactive	
	0	Encoder Assignment when S3 active; S0, S1, S2 inactive	

TABLE 3-20: SEED BUTTON ASSIGNMENT CONFIGURATION REGISTERS

Byte Address	Bit	Description	Values
0x61	7	Seed Assignment when S0, S1, S2 active; S3 inactive	0 = Typical transmission 1 = Seed transmission
	6	Seed Assignment when S1, S2 active; S0, S3 inactive	
	5	Seed Assignment when S0, S2 active; S1, S3 inactive	
	4	Seed Assignment when S2 active; S0, S1, S3 inactive	
	3	Seed Assignment when S0, S1 active; S2, S3 inactive	
	2	Seed Assignment when S1 active; S0, S2, S3 inactive	
	1	Seed Assignment when S0 active; S1, S2, S3 inactive	
	0	Reserved	
0x62	7	Seed Assignment when S0, S1, S2, S3 active	
	6	Seed Assignment when S1, S2, S3 active; S0 inactive	
	5	Seed Assignment when S0, S2, S3 active; S1 inactive	
	4	Seed Assignment when S2, S3 active; S0, S1 inactive	
	3	Seed Assignment when S0, S1, S3 active; S2 inactive	
	2	Seed Assignment when S1, S3 active; S0, S2 inactive	
	1	Seed Assignment when S0, S3 active; S1, S2 inactive	
	0	Seed Assignment when S3 active; S0, S1, S2 inactive	

TABLE 3-21: ULTIMATE KEELoQ® TECHNOLOGY SYNCHRONIZATION COUNTER INITIAL VALUE REGISTERS

Byte Address	Bit	Description	Values
0x63	7:0	Synchronization Counter Value, Primary Copy	Least Significant Byte of counter value
0x64	7:0		Middle byte of counter value
0x65	7:0		Most Significant Byte of counter value
0x66	7:0	Synchronization Counter CRC	See Section 3.1 “Counter and Timer Protection”
0x72	7:0	Synchronization Counter Value, Secondary Copy	Least Significant Byte of counter value
0x73	7:0		Middle byte of counter value
0x74	7:0		Most Significant Byte of counter value

TABLE 3-22: CLASSIC KEELoQ® TECHNOLOGY SYNCHRONIZATION COUNTER INITIAL VALUE REGISTERS

Byte Address	Bit	Description	Values
0x67	7:0	Synchronization Counter Value, Primary Copy	Least Significant Byte of counter value
0x68	7:0		Most Significant Byte of counter value
0x69	7:0	Synchronization Counter CRC	See Section 3.1 “Counter and Timer Protection”
0x76	7:0	Synchronization Counter Value, Secondary Copy	Least Significant Byte of counter value
0x77	7:0		Most Significant Byte of counter value

TABLE 3-23: ULTIMATE KEELoQ® TECHNOLOGY RESET COUNTER INITIAL VALUE REGISTERS

Byte Address	Bit	Description	Values
0x6A	7:0	Synchronization Counter Value, Primary Copy	Least Significant Byte of counter value
0x6B	7:0		Most Significant Byte of counter value
0x6C	7:0	Synchronization Counter CRC	See Section 3.1 “Counter and Timer Protection”
0x79	7:0	Synchronization Counter Value, Secondary Copy	Least Significant Byte of counter value
0x7A	7:0		Most Significant Byte of counter value

TABLE 3-24: ULTIMATE KEELoQ® TECHNOLOGY TIMER INITIAL VALUE REGISTERS

Byte Address	Bit	Description	Values
0x6D	7:0	Timer Value, Primary Copy	Least Significant Byte of counter value
0x6E	7:0		Byte 1 of the counter value
0x6F	7:0		Byte 2 of the counter value
0x70	7:0		Most Significant Byte of counter value
0x71	7:0	Timer CRC	See Section 3.1 “Counter and Timer Protection”
0x7C	7:0	Timer Value, Secondary Copy	Least Significant Byte of counter value
0x7D	7:0		Byte 1 of the counter value
0x7E	7:0		Byte 2 of the counter value
0x7F	7:0		Most Significant Byte of counter value

MCS3142

4.0 CLASSIC KEELOQ® TECHNOLOGY OPERATION

4.1 Synchronization Counter

This is the 16-bit synchronization value that is used to create the hopping code for transmission. This value will be incremented after every transmission. The initial value of the synchronization counter may be set via the Synchronization Counter Initial Value registers (see [Table 3-22](#)).

4.2 DISC Bits

The Discrimination bits are used to validate the decrypted code word. The discrimination value is typically programmed with the ten Least Significant bits of the serial number or some other fixed value, as desired by the manufacturer.

The Discrimination bits are programmed into the Configuration registers at program-time. See [Table 3-5](#).

4.3 Function Code (Button Status Code)

The function code is a bitmapped representation of the state of each button on the transmitter. States are active-high.

TABLE 4-1: CLASSIC KEELOQ® BUTTON CODE TRANSLATION

Button	Function Code
S0	xxx1
S1	xx1x
S2	x1xx
S3	1xxx

4.4 Serial Number

Each Classic KEELOQ encoder transmits its 28-bit serial number with each transmission. It is intended that this serial number be unique to a system. It is set in the Serial Number Configuration registers, described in [Table 3-4](#).

4.5 Code Word Format

FIGURE 4-1: CLASSIC KEELOQ® CODE WORD FORMAT

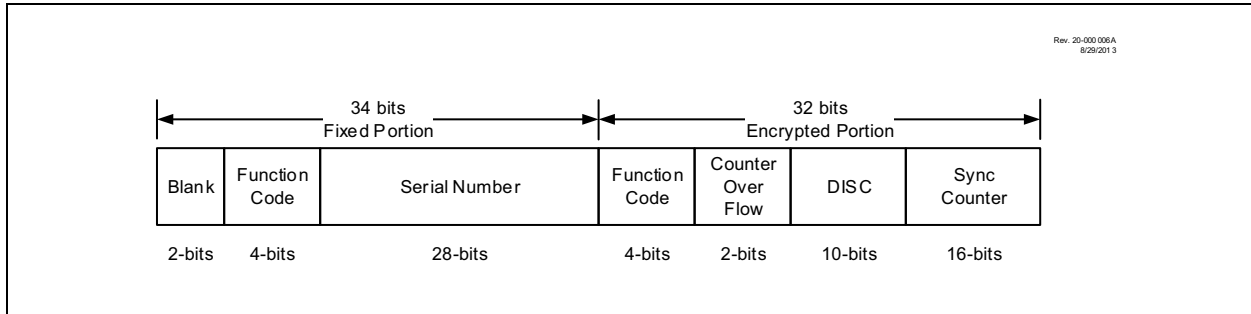

4.5.1 HOPPING CODE PORTION

The hopping code portion is calculated by encrypting the synchronization counter, discrimination value and function code with the encoder key. The hopping code is calculated when a button press is registered.

4.5.2 FIXED CODE PORTION

The fixed code portion consists of 28 bits of the serial number and a copy of the 4-bit function code. Two bits of constant zero are prepended to the fixed code portion.

4.5.3 SEED WORD FORMAT

A seed transmission transmits a code word that consists of 60 bits of fixed data that is stored in the NVM by the manufacturer. This can be used for secure learning of encoders or whenever a fixed code transmission is required. The seed code word format is shown in Figure 4-2. The function code for a seed transmission is always '1111'.

The seed word is transmitted whenever a seed-configured button combination is registered. If the *Delayed* option is enabled, the encoder will transmit 25 typical code words before transmitting seed words. If the *Limited* option is enabled, the seed word will only be transmitted if the encoder's synchronization counter is less than 256. If the synchronization counter is above this, a typical code word will be transmitted instead.

FIGURE 4-2: CLASSIC KEELOQ® SEED WORD FORMAT

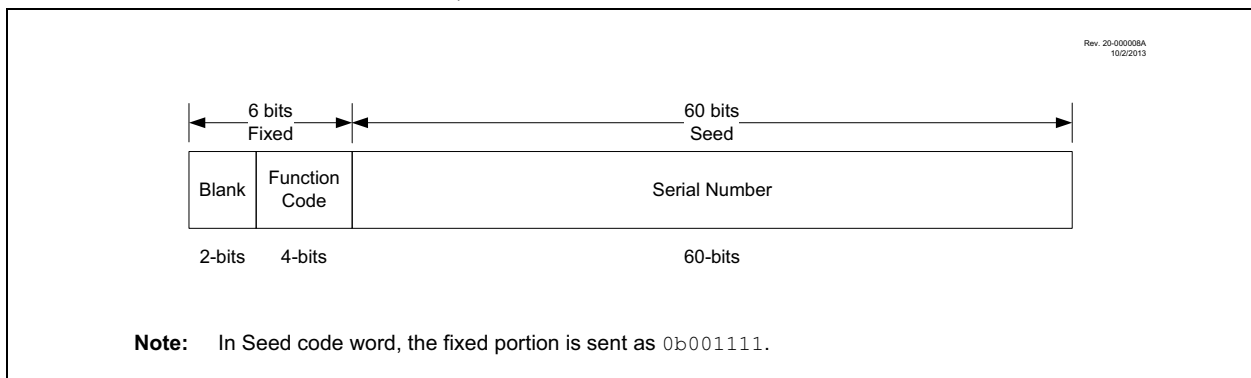

5.0 ULTIMATE KEELOQ TECHNOLOGY OPERATION

5.1 Synchronization Counter

The synchronization counter is an always-incrementing, event-based counter. The counter is incremented whenever a new button combination is registered and a new code word is prepared.

For increased security, the synchronization counter will not overflow. The device will cease operating when the counter reaches its maximum value.

The initial value of the synchronization counter may be set via the Synchronization Counter Initial Value registers (see [Table 3-21](#)).

5.2 Encoder Time-Stamp

MCS3142 requires an external 31.768 kHz oscillator connected to the secondary oscillator drive pins of the internal timer. This timer is used to track the passage of time over the lifetime of the encoder. Each Ultimate KEELOQ transmission includes this time with quarter-second resolution (i.e., each count represents one quarter of a second).

The initial value of the timer may be set at programming time via the Timer Initial Value registers, described in [Table 3-24](#).

5.3 Function Code

The function code is a bitmapped representation of the state of each button on the transmitter. States are active-high.

TABLE 5-1: ULTIMATE KEELOQ[®] FUNCTION CODE TRANSLATION

Button	Function Code
S0	xxx1
S1	xx1x
S2	x1xx
S3	1xxx

5.4 Battery Level and Low Battery Flag

Each Ultimate KEELOQ transmission contains a battery level indicator byte. It includes a 7-bit digital representation of the battery level and a 1-bit low battery flag. The battery level is captured by measuring an on-board 1.024V source using the battery as reference. The low battery flag is high whenever the measured battery voltage is estimated to be below 2.5V. [Equation 5-1](#) converts the reference value into a voltage.

EQUATION 5-1:

$$V_{BAT} = \frac{1.024 \times 2^7}{BATT}$$

5.5 Button Press Timer

The button press timer is a high-resolution timer representing the duration of the current button press at the time the code word was prepared. Each count represents 50 ms of time. It resets whenever a new button combination is registered.

5.6 Delta Time

The delta time represents the elapsed time since the previous code word was sent. The timer increments every second.

5.7 Reset Counter

The Reset counter is an always-incrementing counter representing the number of Power-on Reset events experienced by the device. It is intended to be used by the receiver as an indication that the transmitter has been without power and that there will be a discrepancy in the time-stamp.

For increased security, the Reset counter will not overflow. The device will cease operating when the counter reaches its maximum value.

The initial value of the Reset counter may be set using the Reset Counter Configuration registers, described in [Table 3-23](#).

5.8 Authorization Code

The Authorization Code is a cryptographically-strong industry standard representation of the code word suitable for authentication and integrity verification. It is generated by using the on-board AES encryption algorithm in CBC-MAC mode. The calculation takes place over the entire code word, including the encrypted and unencrypted portions, using the Authorization Key as input. [Figure 5-1](#) shows a representation of how this calculation is performed. This calculation is truncated to its Least Significant 32 bits for transmission.

The Authorization Code requires a shared secret called the Authorization Key. This key is set in the Authorization Key Configuration Register, described in [Table 3-13](#).

FIGURE 5-1: AUTHORIZATION CODE CALCULATION

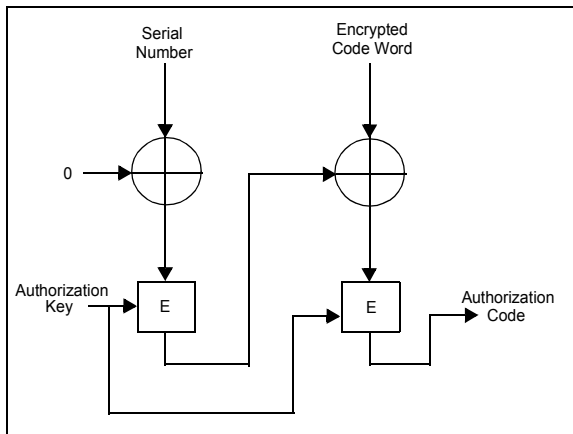

5.9 Serial Number

Each Ultimate KEELOQ encoder transmits its 32-bit serial number with each transmission. It is intended that this serial number be unique to a system. It is set in the Serial Number Configuration registers, described in [Table 3-12](#).

MCS3142

5.10 Code Word Format

The Ultimate KEELOQ technology code word is 192 bits long. It comprises three sections (see Figure 5-2):

- 32 bits of the encoder's serial number
- 128 bits of the encrypted hopping code
- 32 bits of authorization code

These segments are described in detail in the following sections.

FIGURE 5-2: ULTIMATE KEELOQ® CODE WORD FORMAT

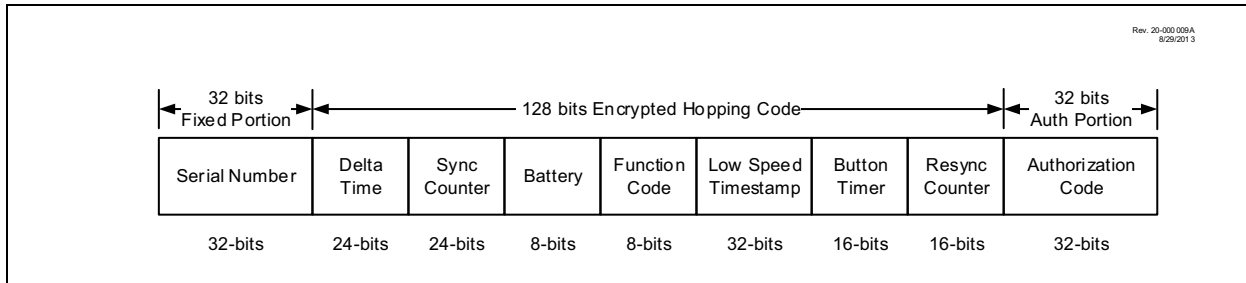

5.10.1 HOPPING CODE PORTION

The hopping portion of an Ultimate KEELOQ code word contains nearly all of the transmitted data. The time-stamp and Button Timer ensure that each transmission is unique.

5.10.2 FIXED CODE PORTION

The fixed, unencrypted portion of an Ultimate KEELOQ code word consists of the encoder's serial number. Unlike Classic KEELOQ, there is no copy of the function code.

5.10.3 AUTHORIZATION CODE

The 32-bit Authorization Code is appended after the hopping portion of the code word.

5.11 Seed Word Format

The seed word is used when pairing the transmitter to a receiver using a secure learn methodology.

FIGURE 5-3: ULTIMATE KEELOQ® SEED WORD FORMAT

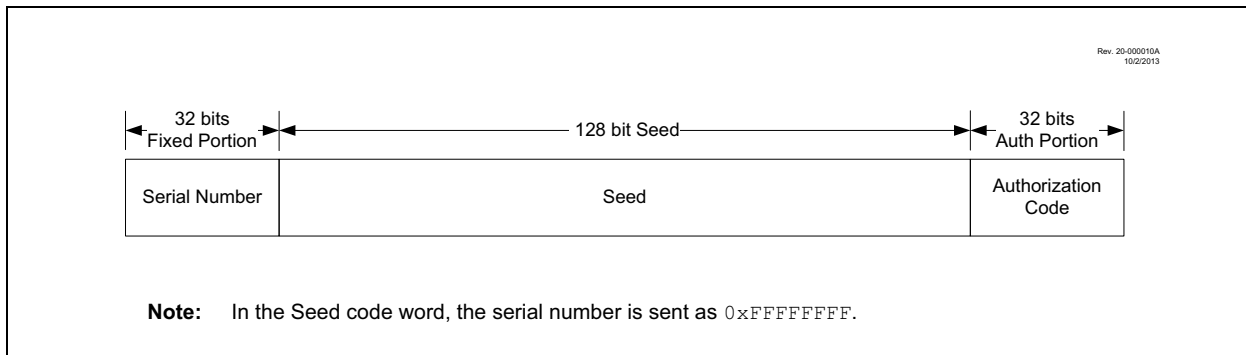

6.0 TRANSMITTER OPERATION

6.1 Data Modulation Format and Baud Rate

A transmission is made of up several code words. Each code word contains a preamble, header and data. A code word is separated from another code word by guard time.

All timing specifications for the modulation formats are based on a basic Time Element, described as T_E . See [Section 6.2 "Baud Rate"](#) for details on baud rate calculation. This timing element can be set to a wide range of values. The length of the preamble, header and guard is fixed.

The data modulation format is selected for each encoder. See [Table 3-6](#) for the Classic KEELOQ encoder and [Table 3-14](#) for Ultimate KEELOQ encoder.

FIGURE 6-1: PWM TRANSMISSION FORMAT

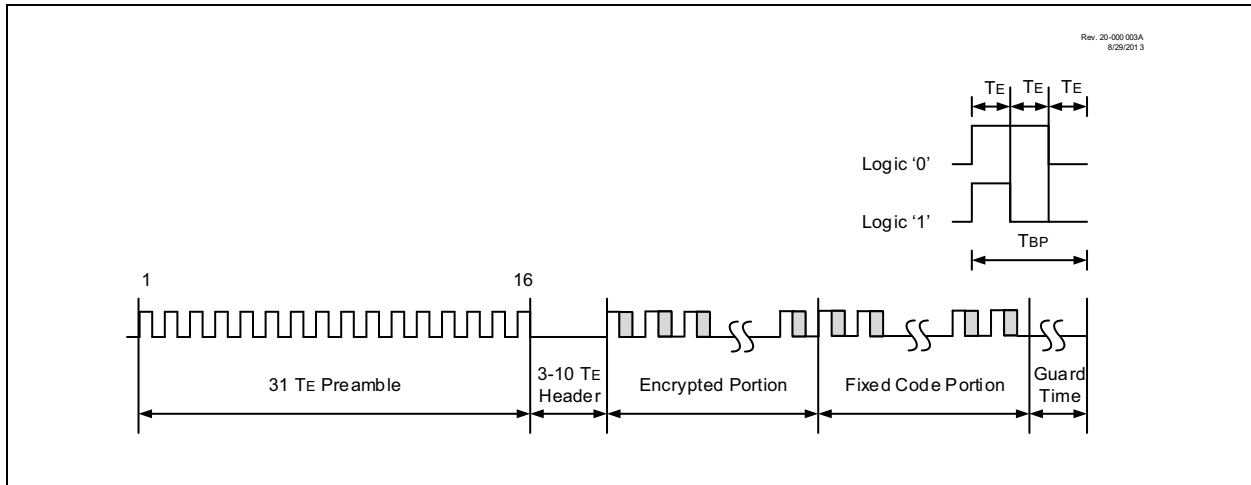
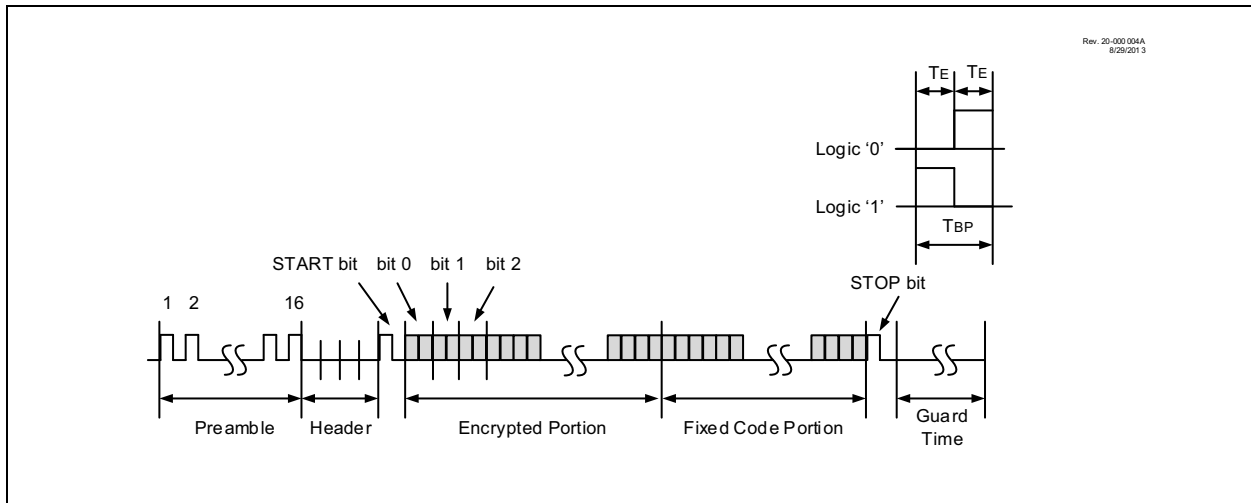

FIGURE 6-2: MANCHESTER TRANSMISSION FORMAT



6.2 Baud Rate

The baud rate of an encoder's transmission is highly configurable using two configuration options:

- The Time Element Clock Prescaler
- The Time Element Clock Value

Each encoder has its own independent configuration and can therefore operate at a rate independent of the other encoder. See [Table 3-6](#) and [Table 3-9](#) for the Classic KEELOQ encoder and [Table 3-14](#) and [Table 3-17](#) for the Ultimate KEELOQ encoder.

The Time Element is calculated using the formula in [Equation 6-1](#).

EQUATION 6-1:

$$T_E = PRE \times TIME \times \frac{4}{8 \times 10^6}$$

[Table 3-17](#) lists appropriate settings for some baud rates common to KEELOQ systems.

TABLE 6-1: CONFIGURATION FOR COMMON BAUD RATES

T_E (μ s)	PRE	TIME
100	1:1	200
200	1:4	100
400	1:4	200
800	1:16	100

6.3 Transmission Modulation Format

The RF transmission can be configured to modulate using Frequency-Shift Keying (FSK) or On-Off Keying (OOK). Each encoder may be configured independently. See [Table 3-7](#) and [Table 3-15](#) for the Classic KEELOQ and Ultimate KEELOQ encoders, respectively.

6.4 Center Frequency and Frequency Deviation

The RF transmitter is capable of generating many of the popular RF frequencies that are permitted within the radio regulations of the country the finished product will be sold. The RF frequency configuration is performed by selecting the frequency band, the reference crystal frequency and the frequency value to be stored in the Encoder Frequency Configuration register. If FSK modulation is used, the frequency deviation is set in the Transmitter Configuration register.

Unlike other configuration options, the two encoders of the MCS3142 device share the same frequency configuration, which is shown in Table 3-18. Frequency deviation is individually configurable. See Table 3-7 and Table 3-15 for the Classic KEELOQ and Ultimate KEELOQ encoders, respectively.

6.4.1 BAND SELECTION

The Band bit in the Transmitter Configuration register configures the RF transmitter for a range of frequencies for a given crystal frequency, as shown in Table 6-2. The Transmitter Configuration registers are shown in Table 3-7 for the Classic KEELOQ encoder and Table 3-15 for the Ultimate KEELOQ encoder.

Although each encoder has its own band selection configuration, the requirements of proper antenna tuning and the inability to configure the fundamental frequency per encoder will likely require that this setting be identical for both encoders.

TABLE 6-2: FREQUENCY CALCULATION⁽¹⁾

Reference Oscillator (f_{REF})	Band	Frequency Range (f_{RF})	f_{RF} Equation	f_{DEV} Equation
22 MHz	0	310-450 MHz	$DF = 2^{14} \frac{f_{RF}}{f_{REF}}$	$DA = 2^{14} \frac{f_{DEV}}{f_{REF}}$
24 MHz		312-450 MHz		
26 MHz		338-450 MHz		
	1	860-928 MHz	$DF = 2^{13} \frac{f_{RF}}{f_{REF}}$	$DA = 2^{13} \frac{f_{DEV}}{f_{REF}}$

Note 1: $212992 < DF < 344064$ and $10 \text{ kHz} \leq f_{DEV} \leq 200\text{kHz}$.

The reference crystal frequency tolerance and frequency stability over the operating temperature range depend on the system frequency budget. Typically, the receiver crystal frequency tolerance, stability and receiver bandwidth will have the greatest influence. For OOK modulation, the transmitted RF signal should remain inside the receiver bandwidth, otherwise signal degradation will occur. For FSK modulation, f_{RF} should remain inside the receiver bandwidth and within $0.5 f_{DEV}$.

As a general practice, do not choose an RF transmit signal with an integer or near integer multiple of f_{XTAL} . This will result in higher noise and spurious emissions.

MCS3142

6.4.2 CRYSTAL SELECTION

Once the frequency band has been selected, the choice of crystal frequency is flexible provided the crystal meets the specifications summarized in [Table 6-3](#), the boundaries of the Encoder Frequency Configuration value are followed and the RF transmit frequency error is acceptable to the system design.

TABLE 6-3: CRYSTAL RESONATOR SPECIFICATIONS

Symbol	Description	Min.	Typ.	Max.	Unit
f_{REF}	Crystal Frequency	22	—	26	MHz
CL	Load Capacitance	—	15	—	pF
ESR	Equivalent Series Resistance	—	—	100	Ω

6.4.3 FREQUENCY CALCULATION

Once the frequency band and crystal frequency are selected, the transmit frequency is calculated by setting the Encoder Frequency Configuration bits according to the formula shown in [Table 6-2](#). If the calculated value for Encoder Frequency Configuration is not an integer, there will be an associated transmit frequency error.

6.4.4 POWER OUTPUT

The RF output power is configurable to either +0 dBm or +10 dBm (typical). This option is configurable for each encoder. See [Table 3-7](#) for the Classic KEELOQ encoder and [Table 3-15](#) for the Ultimate KEELOQ encoder.

7.0 DEVICE OPERATION

7.1 LED Operation

The $\overline{\text{LED}}$ pin will be driven low periodically while MCS3142 is transmitting data. This output is designed to drive an external LED with an appropriate current-limiting resistor. The duty cycle varies between normal operation and a low battery condition (see Figure 7-1). Refer to Section 5.4 “Battery Level and Low Battery Flag” for details on low battery conditions.

FIGURE 7-1: LED OPERATION

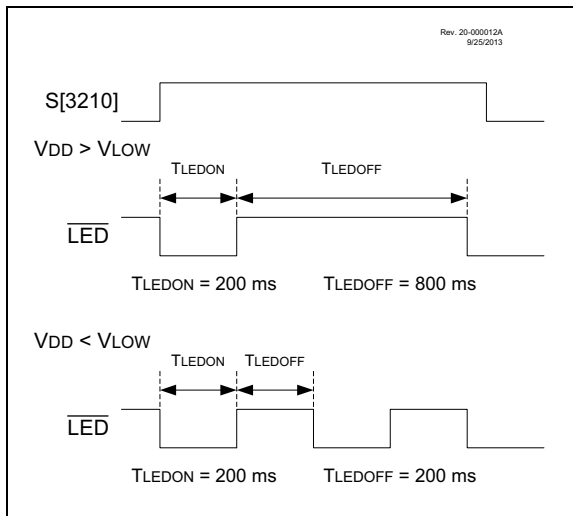

7.2 Button Configuration

MCS3142 allows all combinations of the four buttons to be individually assigned to an encoder. Each combination can also be assigned to transmit either a

typical code word or a seed word for the assigned encoder. This gives complete flexibility to the system designer.

The button configuration is stored as two 16-bit words. Each bit in a Configuration Word represents one particular combination of active/inactive states of the buttons. The bit is determined by taking the four switches as one 4-bit value, with S0 being Least Significant, followed by S1, S2 and S3. For example, the Configuration bit corresponding to S1 and S2 active (or binary ‘1’) and S0 and S3 inactive (or binary ‘0’) is given by $\{S_3S_2S_1S_0\} = \{0110\}_2 = 6$. Configuration bit zero is considered “do not care” as it represents all buttons in their inactive state, which is a special condition for the encoder.

One Configuration Word controls the encoder assignment, with a ‘0’ representing the Classic KEELOQ encoder and a ‘1’ representing the Ultimate KEELOQ encoder. The second word controls transmission type, with ‘0’ representing a typical transmission and ‘1’ representing a seed transmission. Because the MCS3142 memory is byte-oriented, each 16-bit Configuration Word is stored as two 8-bit bytes in “little endian” order. See Table 3-19 for encoder assignment and Table 3-20 for seed assignment.

Table 7-1 may assist in calculating configuration values by iterating all button state combinations in the order in which they correspond to Configuration bits. In this worksheet, each column represents a specific set of states of the buttons, which in turn represents one bit in the Configuration Word. A stated button, for example S0 or S1, represents that button in its active state. A hyphen in place of a switch label represents that switch in its inactive state. Once all states have been assigned an encoder and a transmission type, the result can be examined as a 16-bit binary number and transcribed into the configuration values.

TABLE 7-1: BUTTON CONFIGURATION WORKSHEET

	S0	—	S0	—	S0	—	S0	—	S0	—	S0	—	S0	—	S0	—	S0	—
	S1	S1	—	—	S1	S1	—	—	S1	S1	—	—	S1	S1	—	—	—	—
	S2	S2	S2	S2	—	—	—	—	S2	S2	S2	S2	—	—	—	—	—	—
	S3	S3	S3	S3	S3	S3	S3	S3	—	—	—	—	—	—	—	—	—	—
	↓	↓	↓	↓	↓	↓	↓	↓	↓	↓	↓	↓	↓	↓	↓	↓	↓	↓
BTN CFG	_____								_____								=	
	Button Configuration Byte 1								Button Configuration Byte 0								LSb	
	* 0 = Classic KeeLoq, 1 = Ultimate KeeLoq																	
Seed CFG	_____								_____								=	
	Seed Button Configuration Byte 1								Seed Button Configuration Byte 0								LSb	
	* 0 = Typical transmission, 1 = Seed transmission																	