



Chipsmall Limited consists of a professional team with an average of over 10 year of expertise in the distribution of electronic components. Based in Hongkong, we have already established firm and mutual-benefit business relationships with customers from,Europe,America and south Asia,supplying obsolete and hard-to-find components to meet their specific needs.

With the principle of “Quality Parts,Customers Priority,Honest Operation,and Considerate Service”,our business mainly focus on the distribution of electronic components. Line cards we deal with include Microchip,ALPS,ROHM,Xilinx,Pulse,ON,Everlight and Freescale. Main products comprise IC,Modules,Potentiometer,IC Socket,Relay,Connector.Our parts cover such applications as commercial,industrial, and automotives areas.

We are looking forward to setting up business relationship with you and hope to provide you with the best service and solution. Let us make a better world for our industry!



Contact us

Tel: +86-755-8981 8866 Fax: +86-755-8427 6832

Email & Skype: info@chipsmall.com Web: www.chipsmall.com

Address: A1208, Overseas Decoration Building, #122 Zhenhua RD., Futian, Shenzhen, China





Is Now Part of



ON Semiconductor®

To learn more about ON Semiconductor, please visit our website at
www.onsemi.com

ON Semiconductor and the ON Semiconductor logo are trademarks of Semiconductor Components Industries, LLC dba ON Semiconductor or its subsidiaries in the United States and/or other countries. ON Semiconductor owns the rights to a number of patents, trademarks, copyrights, trade secrets, and other intellectual property. A listing of ON Semiconductor's product/patent coverage may be accessed at www.onsemi.com/site/pdf/Patent-Marking.pdf. ON Semiconductor reserves the right to make changes without further notice to any products herein. ON Semiconductor makes no warranty, representation or guarantee regarding the suitability of its products for any particular purpose, nor does ON Semiconductor assume any liability arising out of the application or use of any product or circuit, and specifically disclaims any and all liability, including without limitation special, consequential or incidental damages. Buyer is responsible for its products and applications using ON Semiconductor products, including compliance with all laws, regulations and safety requirements or standards, regardless of any support or applications information provided by ON Semiconductor. "Typical" parameters which may be provided in ON Semiconductor data sheets and/or specifications can and do vary in different applications and actual performance may vary over time. All operating parameters, including "Typicals" must be validated for each customer application by customer's technical experts. ON Semiconductor does not convey any license under its patent rights nor the rights of others. ON Semiconductor products are not designed, intended, or authorized for use as a critical component in life support systems or any FDA Class 3 medical devices or medical devices with a same or similar classification in a foreign jurisdiction or any devices intended for implantation in the human body. Should Buyer purchase or use ON Semiconductor products for any such unintended or unauthorized application, Buyer shall indemnify and hold ON Semiconductor and its officers, employees, subsidiaries, affiliates, and distributors harmless against all claims, costs, damages, and expenses, and reasonable attorney fees arising out of, directly or indirectly, any claim of personal injury or death associated with such unintended or unauthorized use, even if such claim alleges that ON Semiconductor was negligent regarding the design or manufacture of the part. ON Semiconductor is an Equal Opportunity/Affirmative Action Employer. This literature is subject to all applicable copyright laws and is not for resale in any manner.



July 2016

MCT9001

8-Pin Dual Channel Phototransistor Optocoupler

Features

- Two Isolated Channels Per Package
- Safety and Regulatory Approvals:
 - UL1577, 4,170 VAC_{RMS} for 1 Minute
 - DIN-EN/IEC60747-5-5, 890 V Peak Working Insulation Voltage

Applications

- AC line/digital logic – isolate high voltage transients
- Digital logic/digital logic – eliminate spurious grounds
- Digital logic/AC triac control – isolate high voltage transients
- Twisted pair line receiver – eliminate ground loop feedthrough
- Telephone/telegraph line receiver – isolate high voltage transients
- High frequency power supply feedback control – maintain floating grounds and transients
- Relay contact monitor – isolate floating grounds and transients
- Power supply monitor – isolate transients

Description

The general purpose optocoupler, MCT9001, has two isolated channels in a standard plastic 8-pin dual-in-line (DIP) package for density applications. Each channel consists of a gallium arsenide infrared emitting diode driving a NPN silicon planar phototransistor. For four channel applications, two packages fit into a standard 16-pin DIP socket.

Functional Schematic

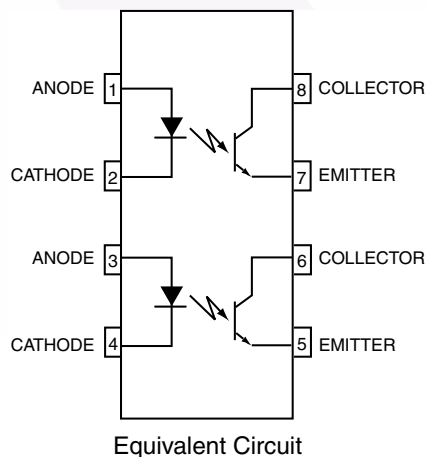

Figure 1. Schematic

Package Outlines

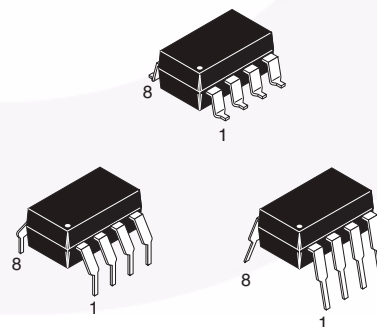

Figure 2. Package Outlines

Safety and Insulation Ratings

As per DIN EN/IEC 60747-5-5, this optocoupler is suitable for “safe electrical insulation” only within the safety limit data. Compliance with the safety ratings shall be ensured by means of protective circuits.

Parameter		Characteristics
Installation Classifications per DIN VDE 0110/1.89 Table 1, For Rated Mains Voltage	< 150 V _{RMS}	I-IV
	< 300 V _{RMS}	I-IV
Climatic Classification		55/115/21
Pollution Degree (DIN VDE 0110/1.89)		2
Comparative Tracking Index		175

Symbol	Parameter	Value	Unit
V _{PR}	Input-to-Output Test Voltage, Method A, V _{IORM} × 1.6 = V _{PR} , Type and Sample Test with t _m = 10 s, Partial Discharge < 5 pC	1424	V _{peak}
	Input-to-Output Test Voltage, Method B, V _{IORM} × 1.875 = V _{PR} , 100% Production Test with t _m = 1 s, Partial Discharge < 5 pC	1668	V _{peak}
V _{IORM}	Maximum Working Insulation Voltage	890	V _{peak}
V _{IOTM}	Highest Allowable Over-Voltage	8000	V _{peak}
	External Creepage	≥ 7	mm
	External Clearance	≥ 7	mm
DTI	Distance Through Insulation (Insulation Thickness)	≥ 0.4	mm
T _S	Case Temperature ⁽¹⁾	175	°C
I _{S,INPUT}	Input Current ⁽¹⁾	60	mA
P _{S,OUTPUT}	Output Power ⁽¹⁾	150	mW
R _{IO}	Insulation Resistance at T _S , V _{IO} = 500 V ⁽¹⁾	> 10 ⁹	Ω

Note:

1. Safety limit values – maximum values allowed in the event of a failure.

Absolute Maximum Ratings

Stresses exceeding the absolute maximum ratings may damage the device. The device may not function or be operable above the recommended operating conditions and stressing the parts to these levels is not recommended. In addition, extended exposure to stresses above the recommended operating conditions may affect device reliability. The absolute maximum ratings are stress ratings only. $T_A = 25^\circ\text{C}$ unless otherwise specified.

Symbol	Parameter	Value	Unit
T_{STG}	Storage Temperature	-55 to +150	$^\circ\text{C}$
T_{OPR}	Operating Temperature	-55 to +100	$^\circ\text{C}$
T_J	Junction Temperature	-55 to +125	$^\circ\text{C}$
T_{SOL}	Lead Solder Temperature	260 for 10 seconds	$^\circ\text{C}$
P_D	Total Device Power Dissipation @ $T_A = 25^\circ\text{C}$	400	mW
	Derate Above 25°C	4.83	mW/ $^\circ\text{C}$
EMITTER (Each channel)			
I_F	DC / Average Forward Input Current	60	mA
$I_F(\text{pk})$	Forward Current - Peak (PW = $1\mu\text{s}$, 300pps)	3	A
V_R	Reverse Input Voltage	5.0	V
$P_{D(\text{EMITTER})}$	Total Power Dissipation @ $T_A = 25^\circ\text{C}$	100	mW
	Derate Above 25°C	1.1	mW/ $^\circ\text{C}$
DETECTOR			
I_C	Continuous Collector Current	30	mA
$P_{D(\text{DETECTOR})}$	Total Power Dissipation @ $T_A = 25^\circ\text{C}$	150	mW
	Derate Above 25°C	1.67	mW/ $^\circ\text{C}$

Electrical Characteristics

$T_A = 25^\circ\text{C}$ unless otherwise specified.

Individual Component Characteristics

Symbol	Parameter	Test Conditions	Min.	Typ.	Max.	Unit
EMITTER						
V_F	Input Forward Voltage	$I_F = 10\text{ mA}$		1.0	1.3	V
I_R	Reverse Leakage Current	$V_R = 5\text{ V}$			10	μA
C_J	Junction Capacitance	$V_F = 0\text{ V}, f = 1\text{ MHz}$		50		pF
DETECTOR						
BV_{CEO}	Collector-to-Emitter Breakdown Voltage	$I_C = 0.5\text{ mA}, I_F = 0$	55			V
BV_{ECO}	Emitter-to-Collector Breakdown Voltage	$I_E = 100\text{ }\mu\text{A}, I_F = 0$	7			V
I_{CEO}	Collector-to-Emitter Dark Current	$V_{CE} = 24\text{ V}, I_F = 0$		5	100	nA
		$V_{CE} = 24\text{ V}, T_A = 85^\circ\text{C}$			50	μA
C_{CE}	Capacitance	$V_{CE} = 0\text{ V}, f = 1\text{ MHz}$		8		pF

Transfer Characteristics

Symbol	Parameter	Test Conditions	Min.	Typ.	Max.	Unit
DC CHARACTERISTICS						
CTR	Current Transfer Ratio, Collector-to-Emitter	$I_F = 5\text{ mA}, V_{CE} = 5\text{ V}$	50		600	%
$CTR_{(SAT)}$		$I_F = 8\text{ mA}, V_{CE} = 0.4\text{ V}$	30			%
$V_{CE(SAT)}$	Saturation Voltage, Collector-to-Emitter	$I_F = 8\text{ mA}, I_C = 2.4\text{ mA}$			0.4	V
AC CHARACTERISTICS						
Non-Saturated						
T_{ON}	Turn-On Time	$R_L = 100\text{ }\Omega, I_C = 2\text{ mA}, V_{CC} = 10\text{ V}$		3.0		μs
T_{OFF}	Turn-Off Time			3.0		μs
T_R	Rise Time			2.4		μs
T_F	Fall Time			2.4		μs
Saturated						
T_{ON}	Turn-On Time	$I_F = 16\text{ mA}, R_L = 1.9\text{ k}\Omega, V_{CE} = 5\text{ V}$		2.4		μs
T_{OFF}	Turn-Off Time			25.0		μs

Isolation Characteristics

Symbol	Parameter	Test Conditions	Min.	Typ.	Max.	Unit
V_{ISO}	Input-Output Isolation Voltage	$I_{I-O} \leq 10\text{ }\mu\text{A}, t = 1\text{ Minute}$	5,000			$V_{AC_{RMS}}$
C_{ISO}	Isolation Capacitance	$f = 1\text{ MHz}$		0.5		pF
R_{ISO}	Isolation Resistance	$V_{I-O} = 500\text{ VDC}$	10^{11}			Ω

Typical Performance Curves

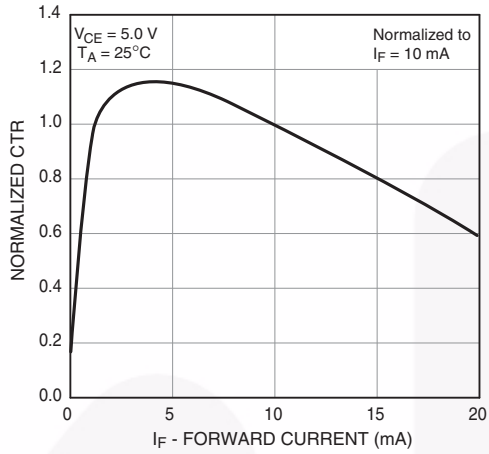

Fig. 3 Normalized CTR vs. Forward Current

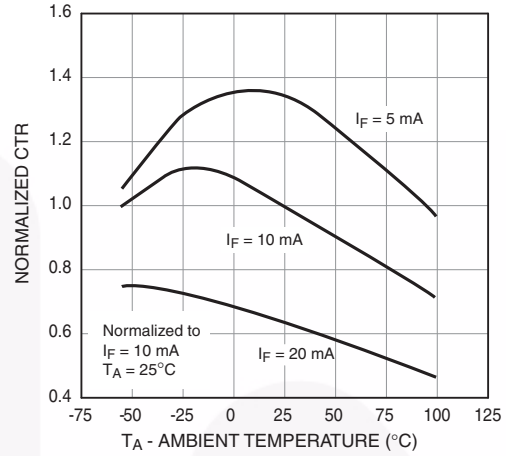

Fig. 4 Normalized CTR vs. Ambient Temperature

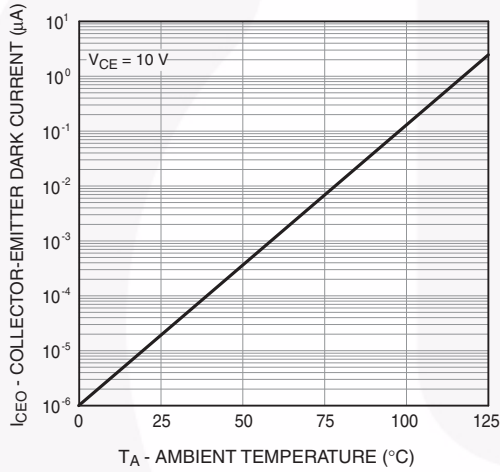

Fig. 5 Dark Current vs. Ambient Temperature

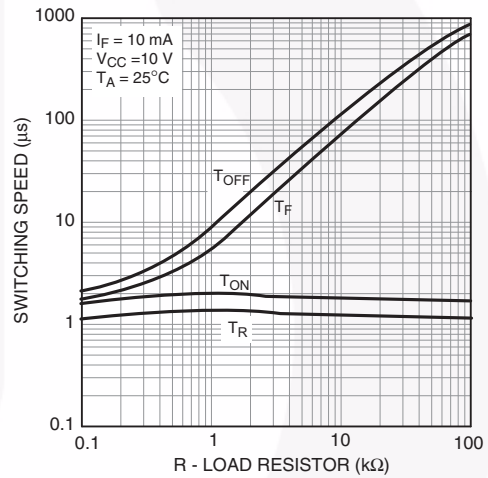

Fig. 6 Switching Speed vs. Load Resistor

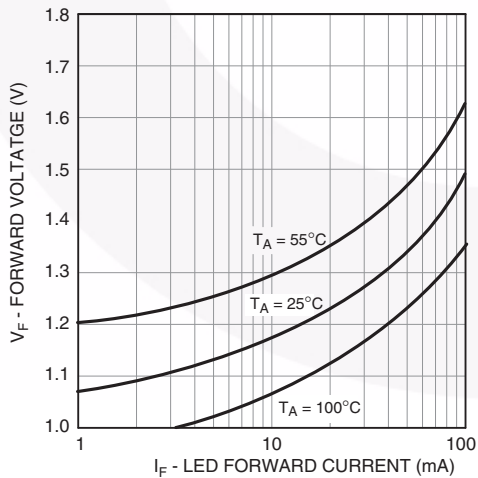

Fig. 7 LED Forward Voltage vs. Forward Current

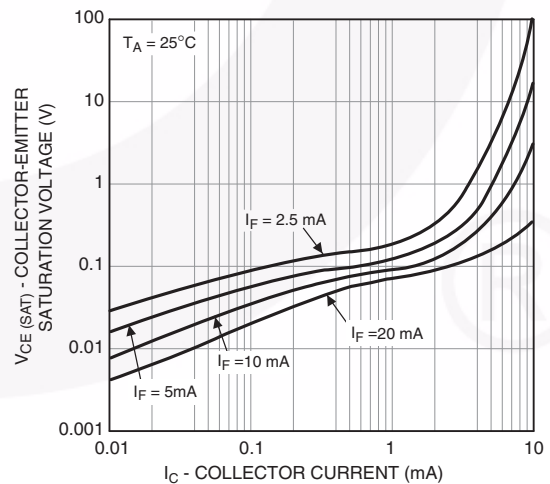

Fig. 8 Collector-Emmitter Saturation Voltage vs. Collector Current

Switching Time Test Circuit and Waveforms

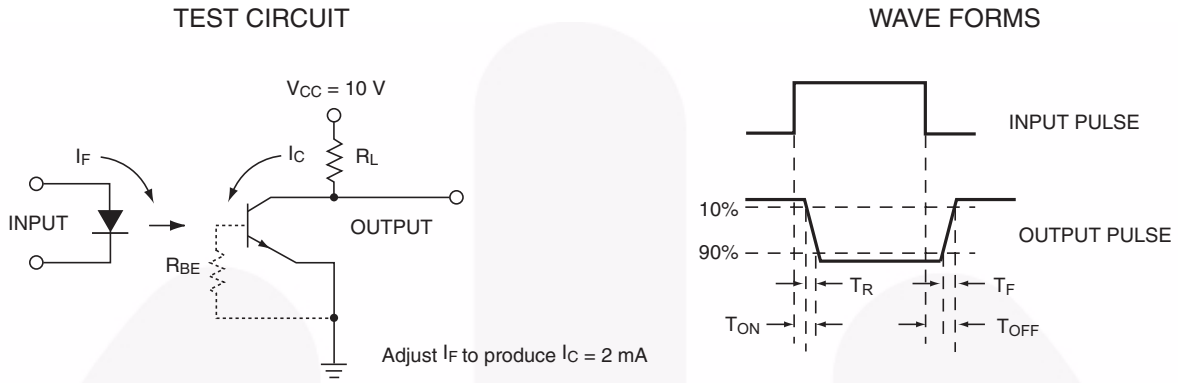
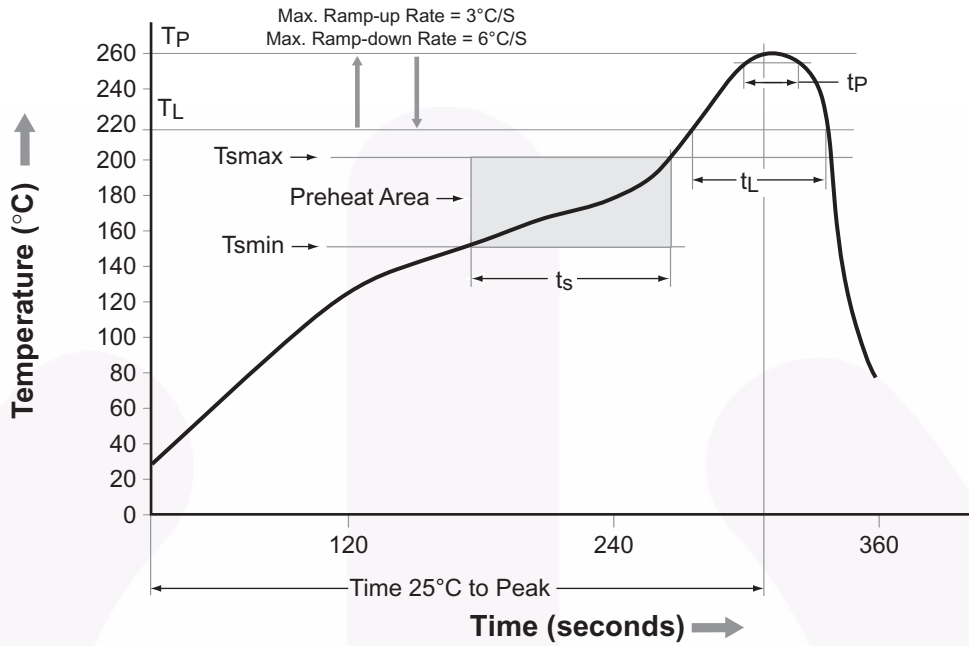

Figure 9. Switching Time Test Circuit and Waveforms

Reflow Profile



Profile Feature	Pb-Free Assembly Profile
Temperature Min. (Tsmín)	150°C
Temperature Max. (Tsmáx)	200°C
Time (ts) from (Tsmín to Tsmáx)	60–120 seconds
Ramp-up Rate (tL to tp)	3°C/second max.
Liquidous Temperature (TL)	217°C
Time (tL) Maintained Above (TL)	60–150 seconds
Peak Body Package Temperature	260°C +0°C / -5°C
Time (tp) within 5°C of 260°C	30 seconds
Ramp-down Rate (TP to TL)	6°C/second max.
Time 25°C to Peak Temperature	8 minutes max.

Ordering Information

Part Number	Package	Packing Method
MCT9001	DIP 8-Pin	Tube (50 units per tube)
MCT9001S	SMT 8-Pin (Lead Bend)	Tube (50 units per tube)
MCT9001SD	SMT 8-Pin	Tape and Reel (1,000 units per reel)
MCT9001300	DIN EN/IEC 60747-5-5 Option	Tube (50 units per tube)
MCT90013S	SMT 8-Pin (Lead Bend); DIN EN/IEC 60747-5-5 Option	Tube (50 units per tube)
MCT90013SD	SMT 8-Pin; DIN EN/IEC 60747-5-5 Option	Tape and Reel (1,000 units per reel)
MCT9001300W	0.4" Lead Spacing; DIN EN/IEC 60747-5-5 Option	Tube (50 units per tube)

Marking Information

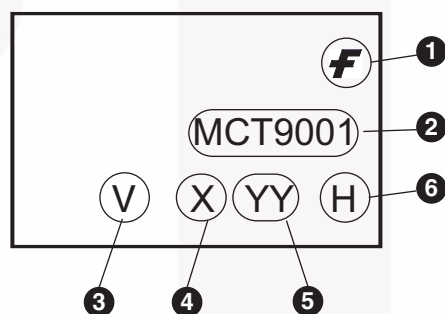
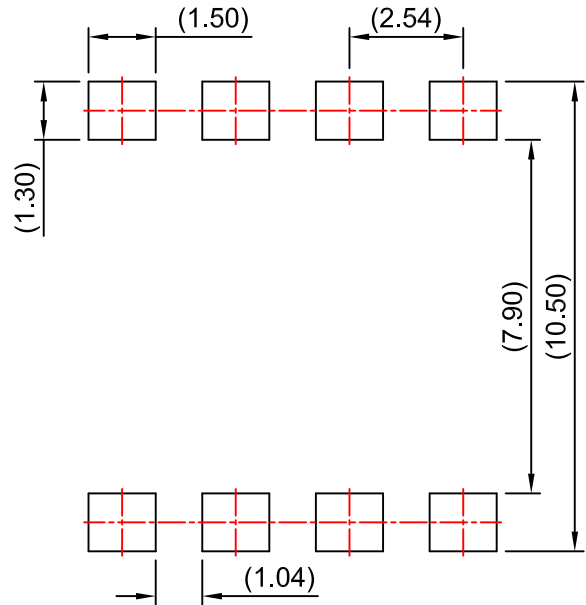
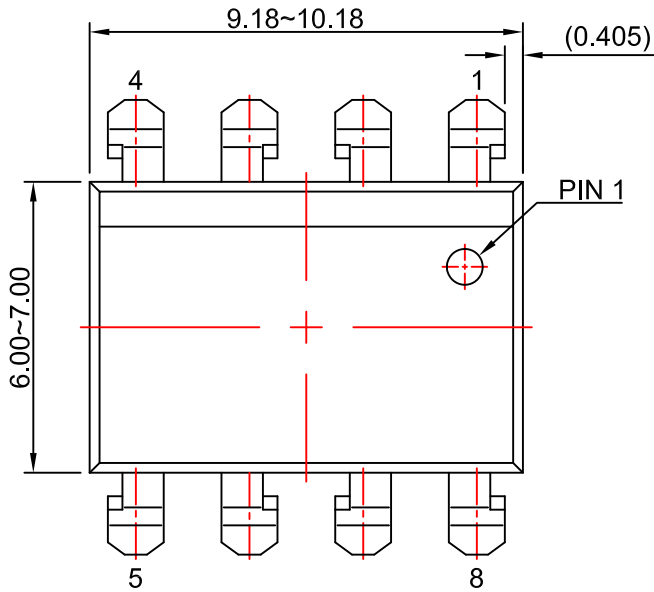

Figure 10. Top Mark

Table 1. Top Mark Definitions

1	Fairchild Logo
2	Device Number
3	DIN EN/IEC60747-5-5 Option (only appears on component ordered with this option)
4	One-Digit Year Code, e.g., "6"
5	Digit Work Week, Ranging from "01" to "53"
6	Assembly Package Code



LAND PATTERN RECOMMENDATION

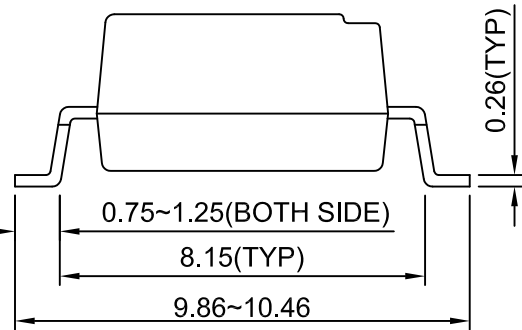
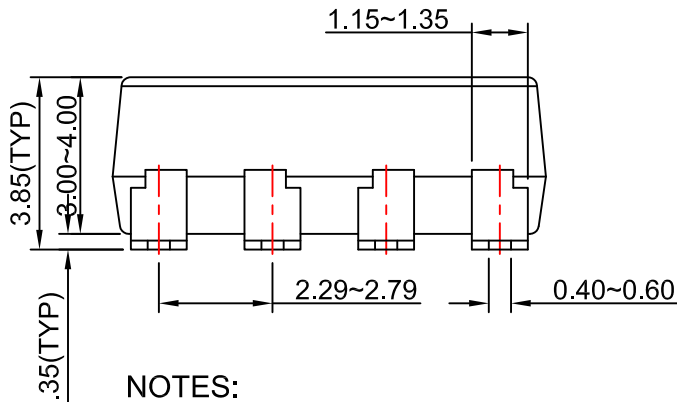

NOTES:

- A) NO STANDARD APPLIES TO THIS PACKAGE.
- B) ALL DIMENSIONS ARE IN MILLIMETERS.
- C) DIMENSIONS ARE EXCLUSIVE OF BURRS, MOLD FLASH, AND TIE BAR EXTRUSION
- D) DRAWING FILENAME AND REVISION: MKT-N08Krev2.



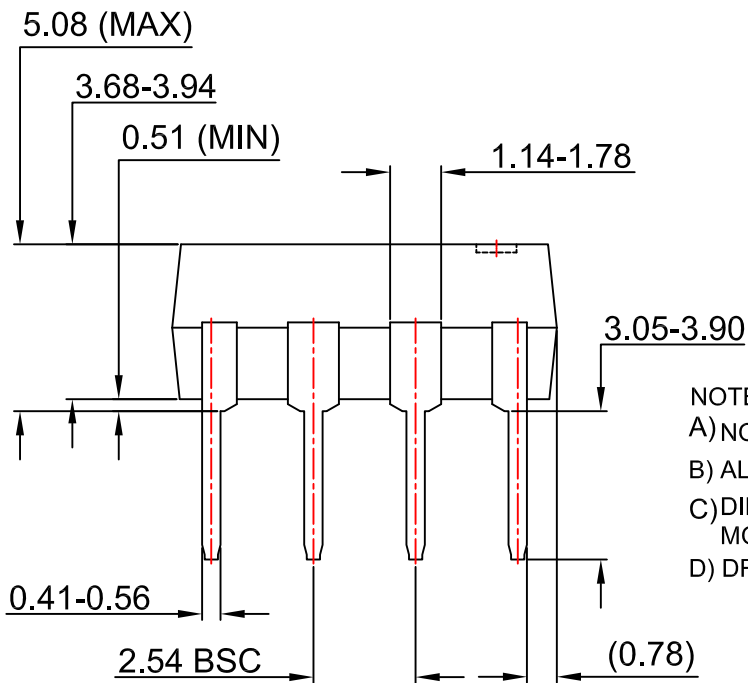
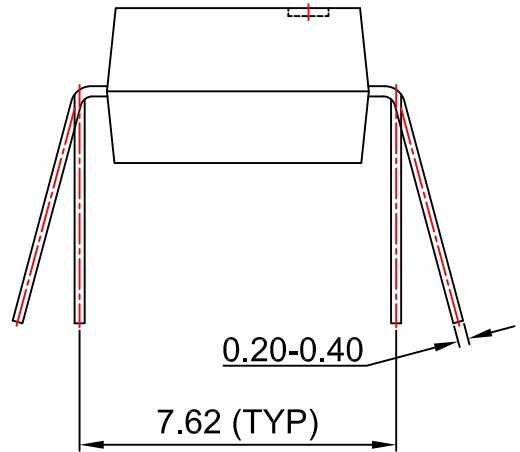
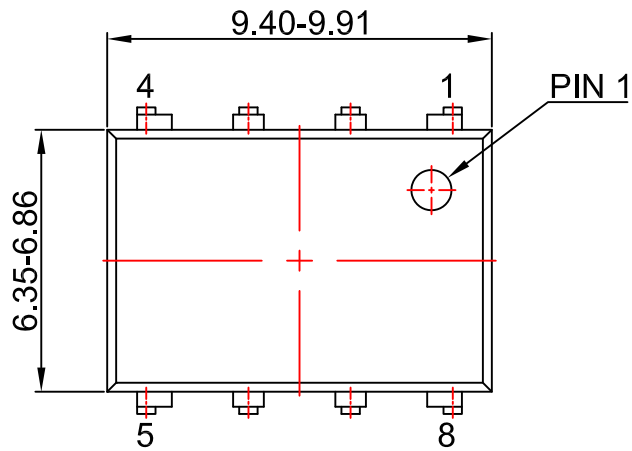

- NOTES:
- A) NO STANDARD APPLIES TO THIS PACKAGE
 - B) ALL DIMENSIONS ARE IN MILLIMETERS.
 - C) DIMENSIONS ARE EXCLUSIVE OF BURRS, MOLD FLASH, AND TIE BAR EXTRUSION
 - D) DRAWING FILENAME AND REVISION: MKT-N08GREV7



ON Semiconductor and  are trademarks of Semiconductor Components Industries, LLC dba ON Semiconductor or its subsidiaries in the United States and/or other countries. ON Semiconductor owns the rights to a number of patents, trademarks, copyrights, trade secrets, and other intellectual property. A listing of ON Semiconductor's product/patent coverage may be accessed at www.onsemi.com/site/pdf/Patent-Marking.pdf. ON Semiconductor reserves the right to make changes without further notice to any products herein. ON Semiconductor makes no warranty, representation or guarantee regarding the suitability of its products for any particular purpose, nor does ON Semiconductor assume any liability arising out of the application or use of any product or circuit, and specifically disclaims any and all liability, including without limitation special, consequential or incidental damages. Buyer is responsible for its products and applications using ON Semiconductor products, including compliance with all laws, regulations and safety requirements or standards, regardless of any support or applications information provided by ON Semiconductor. "Typical" parameters which may be provided in ON Semiconductor data sheets and/or specifications can and do vary in different applications and actual performance may vary over time. All operating parameters, including "Typicals" must be validated for each customer application by customer's technical experts. ON Semiconductor does not convey any license under its patent rights nor the rights of others. ON Semiconductor products are not designed, intended, or authorized for use as a critical component in life support systems or any FDA Class 3 medical devices or medical devices with a same or similar classification in a foreign jurisdiction or any devices intended for implantation in the human body. Should Buyer purchase or use ON Semiconductor products for any such unintended or unauthorized application, Buyer shall indemnify and hold ON Semiconductor and its officers, employees, subsidiaries, affiliates, and distributors harmless against all claims, costs, damages, and expenses, and reasonable attorney fees arising out of, directly or indirectly, any claim of personal injury or death associated with such unintended or unauthorized use, even if such claim alleges that ON Semiconductor was negligent regarding the design or manufacture of the part. ON Semiconductor is an Equal Opportunity/Affirmative Action Employer. This literature is subject to all applicable copyright laws and is not for resale in any manner.

PUBLICATION ORDERING INFORMATION

LITERATURE FULFILLMENT:

Literature Distribution Center for ON Semiconductor
19521 E. 32nd Pkwy, Aurora, Colorado 80011 USA
Phone: 303-675-2175 or 800-344-3860 Toll Free USA/Canada
Fax: 303-675-2176 or 800-344-3867 Toll Free USA/Canada
Email: orderlit@onsemi.com

N. American Technical Support: 800-282-9855 Toll Free
USA/Canada
Europe, Middle East and Africa Technical Support:
Phone: 421 33 790 2910
Japan Customer Focus Center
Phone: 81-3-5817-1050

ON Semiconductor Website: www.onsemi.com
Order Literature: <http://www.onsemi.com/orderlit>
For additional information, please contact your local
Sales Representative