



Chipsmall Limited consists of a professional team with an average of over 10 year of expertise in the distribution of electronic components. Based in Hongkong, we have already established firm and mutual-benefit business relationships with customers from,Europe,America and south Asia,supplying obsolete and hard-to-find components to meet their specific needs.

With the principle of "Quality Parts,Customers Priority,Honest Operation,and Considerate Service",our business mainly focus on the distribution of electronic components. Line cards we deal with include Microchip,ALPS,ROHM,Xilinx,Pulse,ON,Everlight and Freescale. Main products comprise IC,Modules,Potentiometer,IC Socket,Relay,Connector.Our parts cover such applications as commercial,industrial, and automotives areas.

We are looking forward to setting up business relationship with you and hope to provide you with the best service and solution. Let us make a better world for our industry!



Contact us

Tel: +86-755-8981 8866 Fax: +86-755-8427 6832

Email & Skype: info@chipsmall.com Web: www.chipsmall.com

Address: A1208, Overseas Decoration Building, #122 Zhenhua RD., Futian, Shenzhen, China



DO NOT SCALE FROM THIS PRINT

THIS PRODUCT MANUFACTURED WITH LEAD-FREE PROCESSING

DESIGNED & DIMENSIONED IN MILLIMETERS [INCHES]

MCX-J-C-X-ST-CA1

GENDER
-J: JACK

TYPE
-C: CABLE

TERMINATION
-CA1: CABLE
(RG174 OR RG316)

ORIENTATION
-ST: STRAIGHT

PLATING SPECIFICATION
-H: 30µ" GOLD CENTER CONTACT,
3µ" GOLD OUTER CONTACT
(SEE TABLE 1)

TABLE 1		
ITEM	COMPONENT	-H
1	FERRULE	MCX-FER-001-F
2	PIN	MCX-SKT-001-H
3	SUB ASSEMBLY	SUB-MCX-J-C-F-ST-CA 1

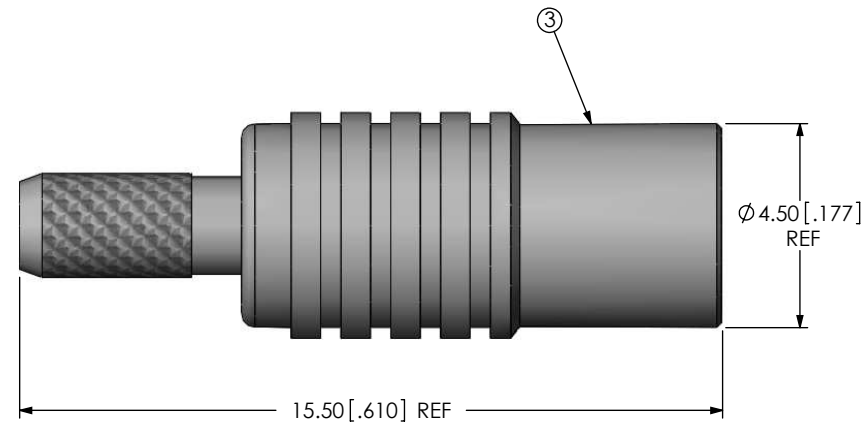
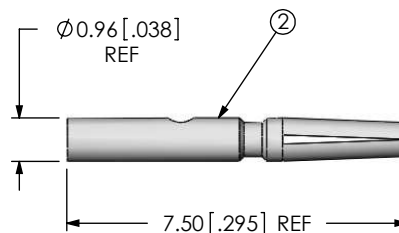
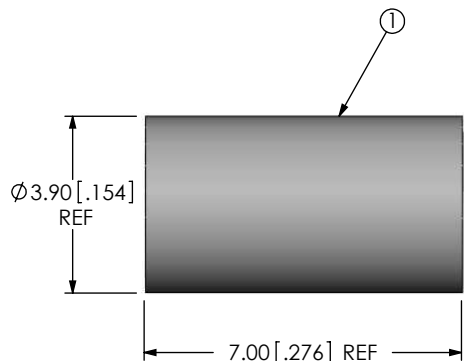

NOTES:

- ⊗ REPRESENTS A CRITICAL DIMENSION.
- CENTER CONTACT PUSHOUT FORCE: 10 N [2.25 LB] MIN.
- NOTE DELETED.
- NOTE DELETED.
- PRODUCT TO BE PACKAGED PER PACKAGING STANDARD CO-HD-WI-3040-M.
- NOTE DELETED.
- NOTE DELETED.
- NOTE DELETED.

F:\DWG\MISC\MKTG\MCX-J-C-X-ST-CA1-MKT.SLDDRW

UNLESS OTHERWISE SPECIFIED, DIMENSIONS ARE IN MILLIMETERS [INCHES]. TOLERANCES ARE: DECIMALS ANGLES .X: ±0.3 [0.1] 5° .XX: ±0.13 [0.05] .XXX: ±0.051 [0.020]	PROPRIETARY NOTE THIS DOCUMENT CONTAINS INFORMATION CONFIDENTIAL AND PROPRIETARY TO SAMTEC, INC. AND SHALL NOT BE REPRODUCED OR TRANSFERRED TO OTHER DOCUMENTS OR DISCLOSED TO OTHERS OR USED FOR ANY PURPOSE OTHER THAN THAT WHICH IT WAS OBTAINED WITHOUT THE EXPRESSED WRITTEN CONSENT OF SAMTEC, INC.	 520 PARK EAST BLVD, NEW ALBANY, IN 47150 PHONE: 812-944-6733 FAX: 812-948-5047 e-Mail: info@SAMTEC.com code: 55322
BY: R MUSSER 02/06/2008		SHEET 1 OF 2

REVISION J

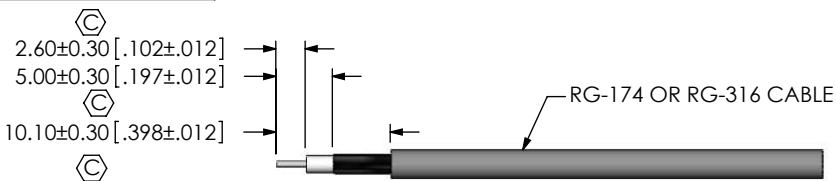

IN-PROCESS 1
STRIP AND TIN INNER CONDUCTOR

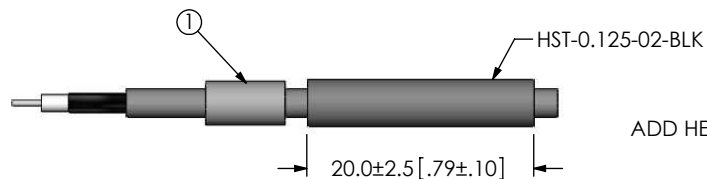

IN-PROCESS 2
ADD HEAT SHRINK TUBE AND FERRULE



IN-PROCESS 3
SOLDER SIGNAL SOCKET

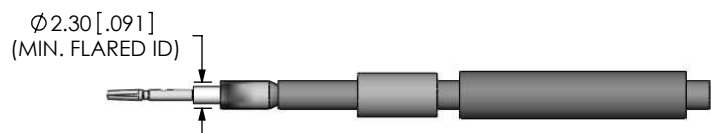

IN-PROCESS 4
FLARE SHIELD

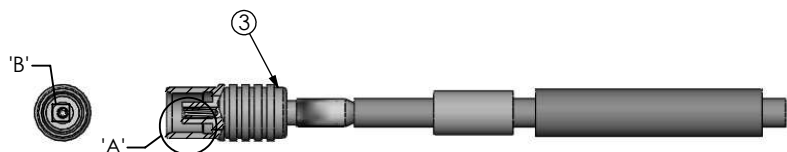

IN-PROCESS 5
ADD SUB ASSEMBLY

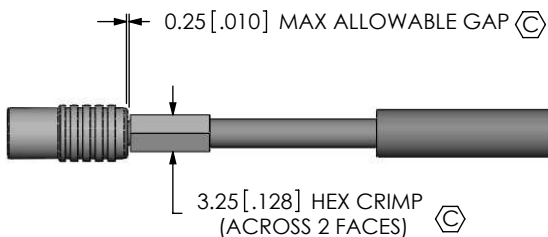

IN-PROCESS 6
CRIMP FERRULE
(USE RF CRIMP HAND TOOL # CAT-HT-126667-21)

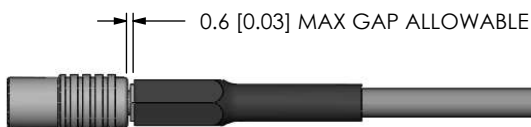

IN-PROCESS 7
APPLY HEAT SHRINK TUBING

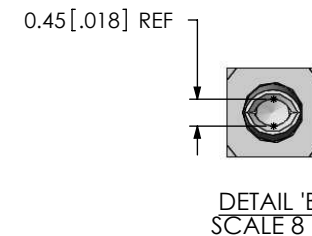
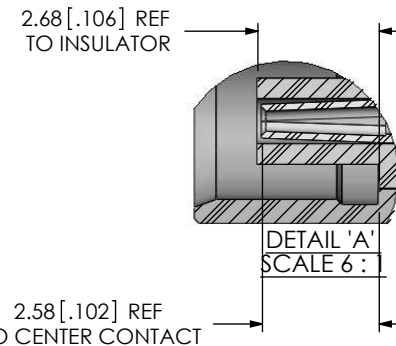

PROPRIETARY NOTE

THIS DOCUMENT CONTAINS INFORMATION CONFIDENTIAL AND PROPRIETARY TO SAMTEC, INC. AND SHALL NOT BE REPRODUCED OR TRANSFERRED TO OTHER DOCUMENTS OR DISCLOSED TO OTHERS OR USED FOR ANY PURPOSE OTHER THAN THAT WHICH IT WAS OBTAINED WITHOUT THE EXPRESSED WRITTEN CONSENT OF SAMTEC, INC.

DO NOT SCALE DRAWING

SHEET SCALE: 1:0.666667



520 PARK EAST BLVD, NEW ALBANY, IN 47150
PHONE: 812-944-6733 FAX: 812-948-5047
e-Mail: info@SAMTEC.com code: 55322

DESCRIPTION:
MCX STRAIGHT CABLE JACK, RG174 & RG316- 50 OHM

DWG. NO.

MCX-J-C-X-ST-CA1

BY: R MUSSER 02/06/2008 SHEET 2 OF 2