



Chipsmall Limited consists of a professional team with an average of over 10 year of expertise in the distribution of electronic components. Based in Hongkong, we have already established firm and mutual-benefit business relationships with customers from,Europe,America and south Asia,supplying obsolete and hard-to-find components to meet their specific needs.

With the principle of “Quality Parts,Customers Priority,Honest Operation,and Considerate Service”,our business mainly focus on the distribution of electronic components. Line cards we deal with include Microchip,ALPS,ROHM,Xilinx,Pulse,ON,Everlight and Freescale. Main products comprise IC,Modules,Potentiometer,IC Socket,Relay,Connector.Our parts cover such applications as commercial,industrial, and automotives areas.

We are looking forward to setting up business relationship with you and hope to provide you with the best service and solution. Let us make a better world for our industry!



Contact us

Tel: +86-755-8981 8866 Fax: +86-755-8427 6832

Email & Skype: info@chipsmall.com Web: www.chipsmall.com

Address: A1208, Overseas Decoration Building, #122 Zhenhua RD., Futian, Shenzhen, China



DO NOT SCALE FROM THIS PRINT

DESIGNED & DIMENSIONED IN MILLIMETERS [INCHES]

MCX7-P-C-XX-ST-CA3

GENDER
-P: PLUG

TERMINATION
-CA3: CABLE (RG179)

TYPE
-C: CABLE

ORIENTATION
-ST: STRAIGHT

PLATING SPECIFICATION

-HN: 30μ" GOLD CENTER CONTACT, 100μ" NICKEL OUTER CONTACT
-H: 30μ" GOLD CENTER CONTACT, 3μ" GOLD OUTER CONTACT (SEE TABLE 1)

TABLE 1			
ITEM	COMPONENT	-HN	-H
1	SUB ASSEMBLY	SUB-MCX7-P-C-FN-ST-CA3	SUB-MCX7-P-C-F-ST-CA3
2	PIN	MCX7-P-C-H-ST-CA3-PIN	
3	OUTER FERRULE	MCX-FER-001-N	MCX-FER-001-F

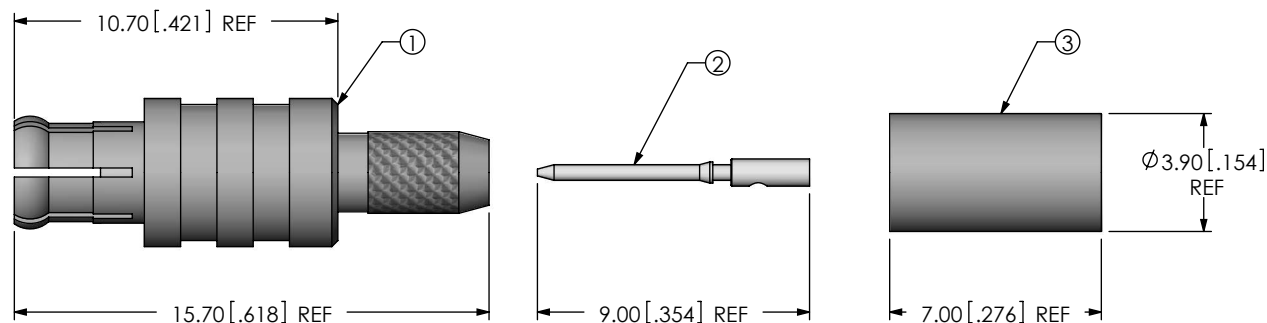

NOTES:

- 1. NOTE DELETED.
- 2. NOTE DELETED.
- 3. NOTE DELETED.
- 4. NOTE DELETED.
- 5. PRODUCT TO BE BULK PACKAGED PER PACKAGING STANDARD CO-RF-WI-3040-M.
- 6. NOTE DELETED.
- 7. NOTE DELETED.
- 8. NOTE DELETED.

F:\DWG\MISC\MKTG\MCX7-P-C-XX-ST-CA3-MKT.SLDDRW

<p>UNLESS OTHERWISE SPECIFIED, DIMENSIONS ARE IN MILLIMETERS [INCHES]. TOLERANCES ARE:</p> <p>DECIMALS ANGLES</p> <p>.X: ±0.3 [.01] 5°</p> <p>.XX: ±0.13 [.005]</p> <p>.XXX: ±0.051 [.0020]</p>	<p>PROPRIETARY NOTE</p> <p>THIS DOCUMENT CONTAINS CONFIDENTIAL AND PROPRIETARY INFORMATION AND ALL DESIGN, MANUFACTURING, REPRODUCTION, USE, PATENT RIGHTS AND SALES RIGHTS ARE EXPRESSLY RESERVED BY SAMTEC, INC. THIS DOCUMENT SHALL NOT BE DISCLOSED, IN WHOLE OR PART, TO ANY UNAUTHORIZED PERSON OR ENTITY NOR REPRODUCED, TRANSFERRED OR INCORPORATED IN ANY OTHER PROJECT IN ANY MANNER WITHOUT THE EXPRESS WRITTEN CONSENT OF SAMTEC, INC.</p>	 <p>520 PARK EAST BLVD, NEW ALBANY, IN 47150 PHONE: 812-944-6733 FAX: 812-948-5047 e-Mail: info@SAMTEC.com code 55322</p>
<p>MATERIAL: DO NOT SCALE DRAWING SHEET SCALE: 4:1</p> <p>SHELL, FERRULES: BRASS CONTACT: BRASS DIELECTRIC: PTFE</p>	<p>DESCRIPTION: TRUE 75 OHM, MCX STRAIGHT PLUG, RG179</p> <p>DWG. NO. MCX7-P-C-XX-ST-CA3</p> <p>BY: R MUSSER 02/06/2008 SHEET 1 OF 2</p>	

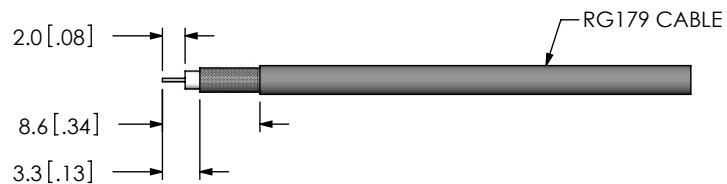

IN-PROCESS 1
STRIP CABLE AND TIN INNER
CONDUCTOR

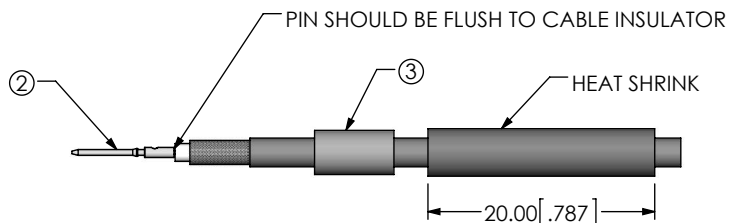

IN-PROCESS 2
ADD HEAT SHRINK TUBING AND FERRULE,
SOLDER SIGNAL PIN

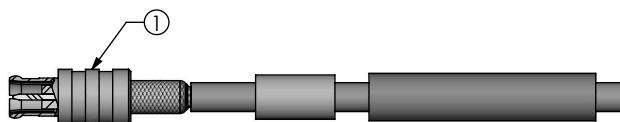

IN-PROCESS 3
FLARE SHIELD & ADD SUB ASSEMBLY

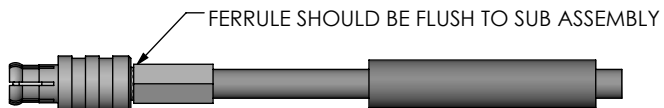

IN-PROCESS 4
CRIMP FERRULE
(USE RF CRIMP HAND TOOL #CAT-RF-FER-01,
AND USE .128" HEX DIE)



IN-PROCESS 5
ACTIVATE HEAT SHRINK

PROPRIETARY NOTE
* THIS DOCUMENT CONTAINS CONFIDENTIAL AND PROPRIETARY INFORMATION AND ALL DESIGN, MANUFACTURING, REPRODUCTION, USE, PATENT RIGHTS AND SALES RIGHTS ARE EXPRESSLY RESERVED BY SAMTEC, INC. THIS DOCUMENT SHALL NOT BE DISCLOSED, IN WHOLE OR PART, TO ANY UNAUTHORIZED PERSON OR ENTITY NOR REPRODUCED, TRANSFERRED OR INCORPORATED IN ANY OTHER PROJECT IN ANY MANNER WITHOUT THE EXPRESS WRITTEN CONSENT OF SAMTEC, INC.

DO NOT SCALE DRAWING

SHEET SCALE: 1.5:1



520 PARK EAST BLVD, NEW ALBANY, IN 47150
PHONE: 812-944-6733 FAX: 812-948-5047
e-Mail info@SAMTEC.com code 55322

DESCRIPTION:
TRUE 75 OHM, MCX STRAIGHT PLUG, RG179

DWG. NO.
MCX7-P-C-XX-ST-CA3

BY: R MUSSER 02/06/2008 SHEET 2 OF 2