



Chipsmall Limited consists of a professional team with an average of over 10 year of expertise in the distribution of electronic components. Based in Hongkong, we have already established firm and mutual-benefit business relationships with customers from,Europe,America and south Asia,supplying obsolete and hard-to-find components to meet their specific needs.

With the principle of “Quality Parts,Customers Priority,Honest Operation,and Considerate Service”,our business mainly focus on the distribution of electronic components. Line cards we deal with include Microchip,ALPS,ROHM,Xilinx,Pulse,ON,Everlight and Freescale. Main products comprise IC,Modules,Potentiometer,IC Socket,Relay,Connector.Our parts cover such applications as commercial,industrial, and automotives areas.

We are looking forward to setting up business relationship with you and hope to provide you with the best service and solution. Let us make a better world for our industry!



Contact us

Tel: +86-755-8981 8866 Fax: +86-755-8427 6832

Email & Skype: info@chipsmall.com Web: www.chipsmall.com

Address: A1208, Overseas Decoration Building, #122 Zhenhua RD., Futian, Shenzhen, China





Analogue, Mixed Signal and Power Management

MC33789

Airbag system basis chip (SBC) with power supply and PSI5 sensor interface

Target Applications

- Automotive Airbag Safety Systems
 - Basic Airbag Systems
 - Advanced Airbag Systems
- Motorcycle - ATV Safety Systems
 - Frame Mounted Single Loop Airbag System

Overview

The MC33789 is a mixed signal IC for airbag safety applications. The MC33789 is a SafeAssure functional safety solution. The MC33789 provides a cost effective and flexible system IC solution across the range of airbag partitions used in cars and other vehicles.

The MC33789 connects to the 12 V vehicle battery and supplies the multiple voltages of a typical airbag system. The MC33789 can detect switched input states, communicate with both local and remote crash sensors. It offers an industry standard interface (SPI) and four PSI5 master interfaces. The MC33789 has a dedicated safing state machine that complements the airbag's MCU hardware/software safing approach. Also included are a diagnostic - self protection capability and a programmable analog interface accessible by the system MCU.

MC33789 Simplified Application Drawing

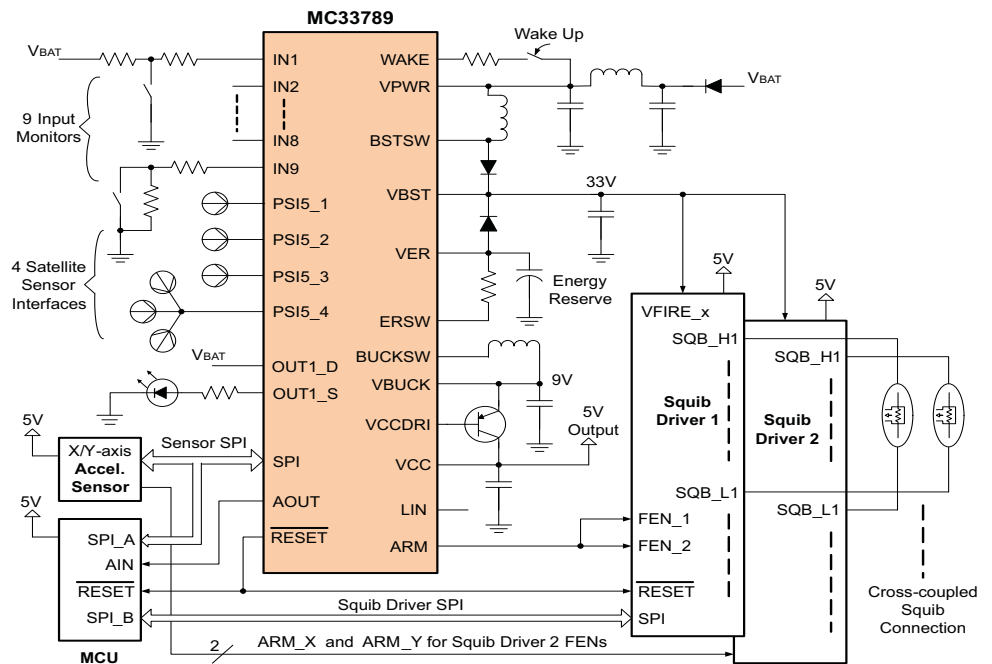

SafeAssure

The MC33789, a SafeAssure solution, is well suited for use in low to high end airbag safety systems by allowing the designer to scale a design for the number of firing loops needed while providing enhanced safety and system reliability.

SafeAssure Program: Functional Safety, Simplified

Freescale's SafeAssure functional safety program is designed to help system manufacturers more easily achieve system compliance with functional safety standards: International Standards Organization (ISO) 26262 and International Electrotechnical Commission (IEC) 61508. The program highlights Freescale solutions – hardware and software – that are optimally designed to support functional safety implementations and come with a rich set of enablement collateral. For more information, visit freescale.com/safeassure.

MC33789 Key Features

- Designed to operate $5.2\text{ V} \leq V_{PWR} \leq 20\text{ V}$, up to 40 V transients
- Safing state machine with programmable sensing thresholds
- Two configurable high side/low side drivers with PWM capability
- Four PSI5 satellite sensor master interfaces
- Self-protected and diagnostic capability
- System power mode control with watchdog and system Power ON Reset (POR)
- Supports complete airbag system power supply architecture, including supplies for squib firing (33 V), satellite sensors (6.3 V), and local ECU sensors and logic circuits (5.0 V)
- Nine configurable switch input monitors for simple switch and Hall-effect sensor interfaces with internal power supply
- 16-bit SPI interface
- LIN 2.1 physical layer interface.

Protection, Performance, and Ordering Information

Performance					
Performance	Typical Values				
Operating Voltage	$5.2\text{ V} \leq V_{PWR} \leq 20\text{ V}$				
Energy Reserve and Squib Firing Supply	33 V				
VCC Supply	5.0 V				
Selectable Switch Input Detector Supplies	1.5 V, 2.5 V, 5.0 V, 6.5 V				
Configurable Driver Output Voltage	$0\text{ V} / V_{PWR}$				
Output Current	Min 70 mA				
PWM Frequency	128 Hz				
Analog Output Voltage	$0\text{ V} \leq V_{AOUT} \leq V_{CC}$				
ESD (HBM)	$\pm 2000\text{ V}$				
Ambient Operating Temperature (T_A)	$-40\text{ }^\circ\text{C}$ to $+125\text{ }^\circ\text{C}$				
Junction Temperature (T_J)	$-40\text{ }^\circ\text{C}$ to $+150\text{ }^\circ\text{C}$				
Protection					
Protection	Detect	Limiting	Shut Down	Auto Retry	Status Report
Over-voltage	•		•	•	•
Over-current/SC	•	•	•		•
Over-temperature	•		•	•	•
Open load	•				•
Ordering Information					
Order Number	Temperature Range			Package	
MCZ33789AE/R2	$-40\text{ }^\circ\text{C}$ to $125\text{ }^\circ\text{C}$			64 LQFP-EP	
Contact Sales	Evaluation board to demonstrate the key features of the MC33789				
MC33789	Data Sheet - Airbag System Basis Chip (SBC) w/ Power Supply and PSI5 Sensor				
SG1002	Selectable Switch Input Detector Supplies				
SG187	Automotive Selector Guide				

Questions

- Question – Why are there no squib drivers integrated?
Answer – The number of squib drivers varies across vehicle platforms so a fixed number could be too many or not enough for an application.
- Question – What drove the MC33789 final silicon partition?
Answer – The MC33789 was the result of collaboration between Freescale and a leading airbag system supplier who addressed the need for low cost vs. flexibility.
- Question – Is the MC33789's PSI5 Interface interoperable with other PSI5 products?
Answer – Yes, Freescale is part of the PSI5 consortium and has an ecosystem of crash sensor parts that communicate with the MC33789. The MC33789's PSI5 master interface supports the P10P 500/3L operation mode specified in the PSI5 standard V1.3.

For more information, please visit freescale.com

Freescale and the Freescale logo are trademarks of Freescale Semiconductor, Inc., Reg. U.S. Pat. & Tm. Off. Qorivva, SafeAssure and Xtrinsic are trademarks of Freescale Semiconductor, Inc. All other product or service names are the property of their respective owners. The Power Architecture and Power.org word marks and the Power and Power.org logos and related marks are trademarks and service marks licensed by Power.org. © 2012 Freescale Semiconductor, Inc.

Document Number: MC33789FS, Rev. 3.0

